

# An Exploration of Dynamic Conservation Voltage Control

Greg Hataway

*PowerSouth Energy Cooperative*

Dallas Jacobsen and Marcos Donolo

*Schweitzer Engineering Laboratories, Inc.*

Presented at the

14th Annual Western Power Delivery Automation Conference

Spokane, Washington

March 27–29, 2012

# An Exploration of Dynamic Conservation Voltage Control

Greg Hataway, *PowerSouth Energy Cooperative*  
Dallas Jacobsen and Marcos Donolo, *Schweitzer Engineering Laboratories, Inc.*

**Abstract**—This paper explores a method of voltage control, with the purpose of energy conservation. The traditional approach of conservation voltage reduction is not always the right approach for all types of feeder loads; some loads run more efficiently at a higher voltage. Furthermore, to take into account that load types change throughout the day and year, this method uses an analytical approach to find the optimal voltage level as the load changes. This method can be implemented at the voltage regulator control without input from remote sensors or controllers. Because there is no need for remote communication, this method is simple to implement and cost-effective.

A program was developed to better understand the correlation between the optimal voltage level and load types. The initial results of that program are presented, along with the challenges encountered.

## I. INTRODUCTION

The subject of conservation voltage reduction (CVR) has recently regained interest in the sphere of distribution engineering. New technology has come to the market that allows utility engineers to analyze the condition of distribution feeders as never before. Yet with this increased amount of data, the challenging question remains—does CVR reduce load or not?

Around 1990, three independent studies found that, typically, it was possible to lower the feeder voltage 1 percent without affecting loads [1] [2] [3]. The studies also found that a voltage reduction of 1 percent led to energy savings between 0.5 and 1 percent. In 2002, a similar study found energy savings between 0.3 and 1.1 percent, depending on the feeder [4]. This study also found that energy savings are not readily available because of the lack of engineering resources to set up CVR schemes and the lack of solid financial information to justify the CVR schemes.

This paper describes an ongoing project that we implemented in two substations in the service area of PowerSouth Energy Cooperative. The goal of this project is to better understand how distribution circuits respond to each voltage tap change from a single-phase voltage regulator. This paper describes the technology and analysis algorithm used, along with the challenges and future work.

## II. STATIC LOAD MODEL PARAMETER ESTIMATION

### A. Introduction

Load models are mathematical functions used to describe the behavior of loads connected to transmission or distribution networks. Load models are not intended to capture variations in demand caused by customers requiring more or less power.

Instead, they capture variations in demand caused by changes in the supply voltage.

Load models may be classified into two categories: static and dynamic. Static load models are defined by algebraic equations. Dynamic load models are defined by differential equations that capture the time evolution of the load. Detailed dynamic simulations require dynamic load models. If the load dynamics are not critical for the simulation, static load models dependent on voltage magnitude and frequency may be used. Power flow studies use static load models that depend on voltage magnitude only.

The mathematical functions in load models include parameters that are tuned so that the model behaves like a particular physical load. Fig. 1 depicts a static load model that provides active power for changes in voltage and frequency.

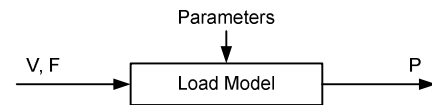

Fig. 1. Static load model

Note that the same change in the supply may cause different changes in demand at different times. For example, when electric resistive heating is the predominant part of a load, a voltage magnitude change causes a load change proportional to the square of the voltage variation. On the other hand, a voltage magnitude change may not cause any change in the demand if power electronics are the predominant part of the load. To accommodate these two extreme cases, any given load model will require at least two different sets of parameters. The appropriate set of parameters should be used to simulate the load under each condition.

Next, we study several common load models.

### B. IEEE Static Load Model

Equation (1) shows the static load model recommended by the IEEE Task Force on Load Representation for Dynamic Performance [5].

$$\begin{aligned} \frac{P}{P_0} = & K_Z \left( \frac{V}{V_0} \right)^2 + K_i \frac{V}{V_0} + K_c + \\ & K_1 \left( \frac{V}{V_0} \right)^{n_{v1}} (1 + n_{f1} (f - f_0)) \Phi(V, V_{a1}, V_{b1}) + \\ & K_2 \left( \frac{V}{V_0} \right)^{n_{v2}} (1 + n_{f2} (f - f_0)) \Phi(V, V_{a2}, V_{b2}) \end{aligned} \quad (1)$$

In (1),  $P_0$  is the initial real power and  $V_0$  is the voltage associated with  $P_0$ . In this equation,  $f_0$  is the nominal frequency (i.e., 60 or 50 Hz).  $V$  and  $f$  are the independent variables, and  $K_s$  and  $n_s$  are the model parameters. The IEEE task force recommendation includes threshold parameters used to linearly reduce the fourth and fifth terms of (1) to zero as the voltage goes below these threshold parameters. The function  $\Phi$ , defined by (2), enforces these threshold parameters.

$$\Phi(V, V_a, V_b) = \begin{cases} 1, & \text{if } V \geq V_a \\ 0, & \text{if } V < V_b \text{ or } V_a > V_b \\ \frac{V - V_b}{V_a - V_b}, & \text{otherwise} \end{cases} \quad (2)$$

Fig. 2 shows the shape of function  $\Phi$ . This function is intended to model loads such as discharge lighting (e.g., fluorescent and metal halide lighting). The power consumed by discharge lighting goes to zero abruptly when voltage is such that the arc cannot reignite.

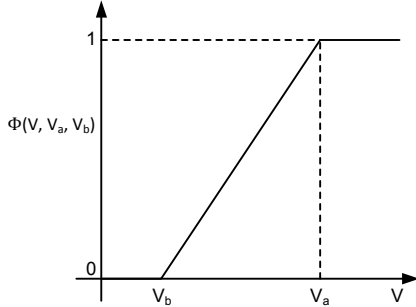

Fig. 2. Threshold parameter function  $\Phi(V, V_a, V_b)$

In addition to the threshold parameters, the following parameters are real numbers larger than zero:

$$K_z, K_i, K_c, K_1, K_2 \in \mathbb{R}^+ \quad (3)$$

The sum of these parameters must be equal to 1, as shown in (4).

$$1 = K_z + K_i + K_c + K_1 + K_2 \quad (4)$$

### C. ZIP Load Model

The ZIP load model looks at the load as a mixture of constant impedance (Z), constant current (I), and constant power (P). This model can be obtained by setting the constraints  $K_1, n_{v1}, n_{f1}, K_2, n_{v2},$  and  $n_{f2}$  equal to 0 on the standard model so that (1) becomes (5).

$$\frac{P}{P_0} = K_z \left( \frac{V}{V_0} \right)^2 + K_i \frac{V}{V_0} + K_c \quad (5)$$

$K_z$  is the constant impedance fraction of the load,  $K_i$  is the constant current fraction of the load, and  $K_c$  is the constant power fraction of the load. The sum of these parameters must be equal to 1, as shown in (6).

$$1 = K_z + K_i + K_c \quad (6)$$

### D. Power System Simulator for Engineering (PSS<sup>®</sup>E) Load Model

A close match to the load model used by PSS<sup>®</sup>E for power flow analysis can be obtained by setting the following constraints on the IEEE standard model (1):

$$\begin{aligned} K_c, n_{v1}, n_{f1}, K_i, V_{b1}, V_{b2}, n_{f2} &= 0 \\ V_{a1} &= \text{PQBRAK} \\ V_{a2} &= 0.5 \\ n_{v2} &= 1 \end{aligned}$$

PQBRAK is a PSS<sup>®</sup>E solution parameter that has one of the following values: 0.6, 0.7, or 0.8 pu. In this model,  $K_1$  represents the constant power fraction of the load and  $K_2$  represents the constant current fraction of the load. The equation of the model is shown in (7).

$$\begin{aligned} \frac{P}{P_0} &= K_z \left( \frac{V}{V_0} \right)^2 + K_1 \Phi(V, V_{a1}, V_{b1}) + \\ &K_2 \left( \frac{V}{V_0} \right) \Phi(V, V_{a2}, V_{b2}) \end{aligned} \quad (7)$$

### E. Exponential Load Model

The exponential load model for power flow analysis can be obtained by setting the following constraints on the standard model (1):

$$\begin{aligned} K_z, K_i, K_c, K_2, V_{a1}, V_{b1}, V_{a2}, V_{b2} &= 0 \\ K_1 &= 1 \\ f &= f_0 \\ K_p &= n_{v1} \end{aligned}$$

This implies the following:

$$\Phi(V, V_{a1}, V_{b1}) = 1$$

$$\Phi(V, V_{a2}, V_{b2}) = 1$$

Therefore, (1) becomes:

$$\frac{P}{P_0} = \left( \frac{V}{V_0} \right)^{K_p} \quad (8)$$

where:

$K_p$  corresponds to  $n_{v1}$  in (1).

The simplified model shown in (8) depends on one coefficient only. When the coefficient  $K_p = 0$ , the load does not change with the voltage (i.e., constant power load); when  $K_p = 2$ , the model behaves like a constant impedance load; and when  $K_p = 1$ , the model behaves like a constant current load.

For our study, we selected the simplified exponential model shown in (8) because of the difficulty in determining the multiple coefficients for other models and because the load behavior can be easily inferred from the coefficient of the model.

To obtain the  $K_p$  coefficient from the voltage regulator measurements, we set  $V_0$  and  $P_0$  to the pre-tap voltage and power measurements and  $V$  and  $P$  to the post-tap voltage and power measurements. Then we compute  $K_p$  using (9).

$$K_p = \frac{\log\left(\frac{P}{P_0}\right)}{\log\left(\frac{V}{V_0}\right)} \quad (9)$$

For example, using data from one of the tap operations, we obtain:

$$K_p = \frac{\log\left(\frac{0.9915}{1}\right)}{\log\left(\frac{0.995}{1}\right)} = 1.7 \quad (10)$$

$K_p$  equal to 1.7 is consistent with a nearly constant impedance load associated with home heating.

### III. ACTUAL VOLTAGE DURING A TAP-CHANGE OPERATION

To maintain the feeder voltage within the allowed range, voltage regulators raise or lower the voltage by changing taps on an autotransformer. To change between autotransformer taps without interrupting the load current, the voltage regulator temporarily allows two taps to be connected in parallel. Connecting two taps in parallel avoids interrupting the load current but creates a current loop inside the autotransformer. To limit the current in this loop, resistors are connected to each of the taps before connecting them in parallel.

Fig. 3 shows, from left to right, the five stages to perform a tap-down operation. The bold red lines indicate the path of the current into the autotransformer. In the pre-tap stage, current flows directly into the autotransformer. In Stage 1, the direct path into the autotransformer is interrupted, diverting the load current through the  $R_a$  resistor. In Stage 2, the tap changer creates a loop between the taps and the load current flows into the autotransformer through both taps. In Stage 3, Tap A is disconnected and current flows through the  $R_b$  resistor. Finally, in the post-tap stage, the  $R_b$  resistor short-circuits, and the load current flows directly into the autotransformer through Tap B.

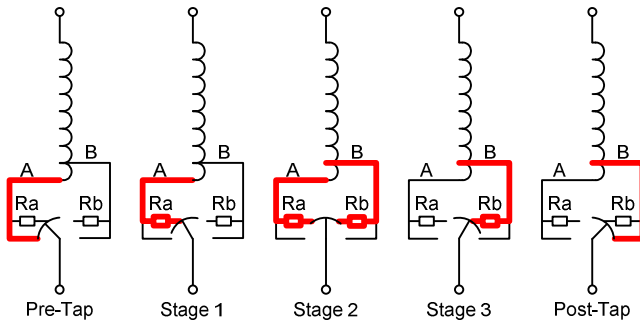

Fig. 3. Tap-down operation

Fig. 4 shows the voltage during a tap-down operation, like the one just described. Stage 2 is not recognizable in Fig. 4 because it takes approximately 4 milliseconds to complete. It is important to note that the voltage during Stage 3 falls below the post-tap level.

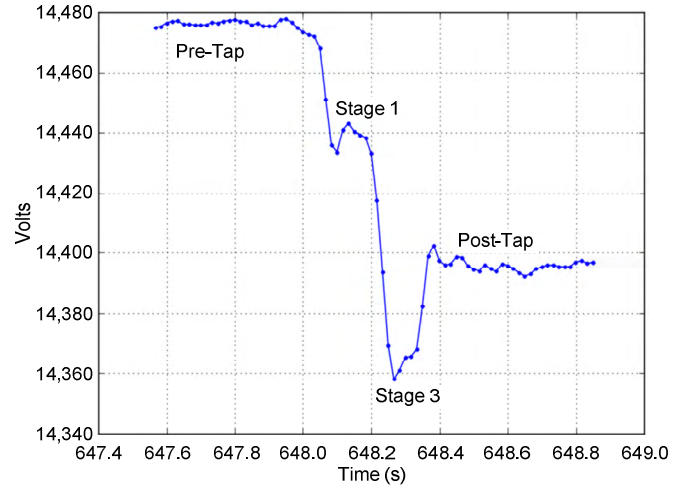

Fig. 4. Voltage during a tap-down operation

### IV. IMPLEMENTATION

To measure the effect of enabling voltage reduction, the “day on, day off” approach was used [6]. This method is commonly used in the industry and considered to be a good means of isolating the effect of voltage reduction on load demand.

Two substations were selected for the project. At each substation, one feeder was selected for testing. At each site, the substation as a whole was metered with 15-minute demand metering, and the circuits under test were metered with 15-minute demand metering. We statistically analyzed the metered quantities at the substation versus the metered quantities on the feeder on days when voltage reduction was enabled compared with days when it was disabled. This comparison quantified the effect that voltage reduction had on a specific feeder.

At both project sites, the voltage regulators under test only controlled one circuit, so the demand profile from each feeder could be compared to the demand profile from the substation as a whole. The 15-minute demand values of the substation were available for comparison with the 15-minute demand values from the feeders. The comparison of these 15-minute values provided a means of comparing the feeder versus substation demand on the days when voltage reduction was enabled with the days when it was disabled.

Both substations are located in the southeast region of the continental United States. The customer profile of these substations is mostly residential, with an occasional farm and commercial load. Seventy-five percent of the customers on these feeders report using electric heat as their primary source; this is important because the data under consideration are from the winter months. The electric heat used most is electric heat

pumps, with resistive heat strips used in extremely cold weather. Also, 87 percent of the customers on these feeders use electric water heaters. Both of these load types are thermostatically controlled, the effect of which will be discussed later. Only 11 percent of the customers report using compact fluorescent lighting for more than half of their lighting needs. This is important because incandescent lighting responds well to CVR for the following two reasons:

- It is a nearly constant impedance load.
- It is not thermostatically controlled.

Substation #1 implemented the following voltage reduction rotation schedule:

- Day 1: voltage reduction off
- Day 2: voltage reduction off
- Day 3: voltage reduction at 3 percent
- Day 4: voltage reduction off

Substation #2 implemented the following voltage reduction rotation schedule:

- Day 1: voltage reduction off
- Day 2: voltage reduction at 2 percent
- Day 3: voltage reduction at 3 percent
- Day 4: voltage reduction off

The regulator switched the voltage reduction set points at 1:01 a.m. each day.

The voltage regulator control sent synchrophasor voltage and current measurements at 60 messages per second to a substation-hardened computer, archiving the data for later analysis.

## V. ANALYSIS

### A. $K_p$ Coefficient

Every time the voltage regulator control initiates a tap change, it calculates the  $K_p$  coefficient using (8). The inputs to this calculation are the phasor measurement unit (PMU) data samples of voltage and power. The initial condition, as defined by  $P_0$  and  $V_0$ , is determined immediately before the tap, and the final condition, as defined by  $V$  and  $P$ , is calculated shortly after the tap operation is complete. Fig. 5 illustrates the timing of these samples.

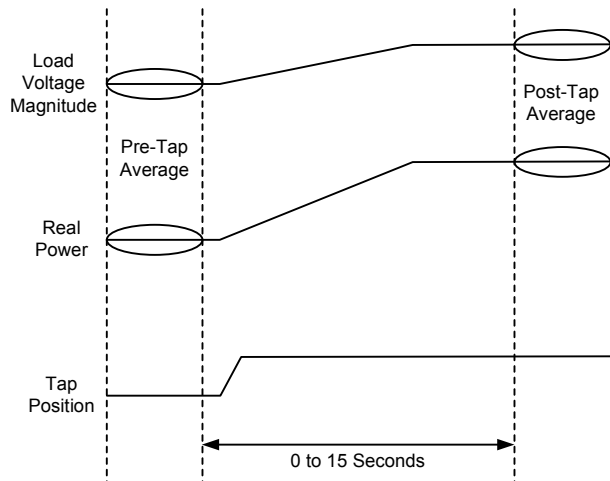

Fig. 5. Timing of voltage and power measurements around the tap operation

The data points collected immediately before and after a tap are shown in Fig. 6. The positive correlation between voltage and power is visible in this graph. These data points are used in the  $K_p$  coefficient calculation.

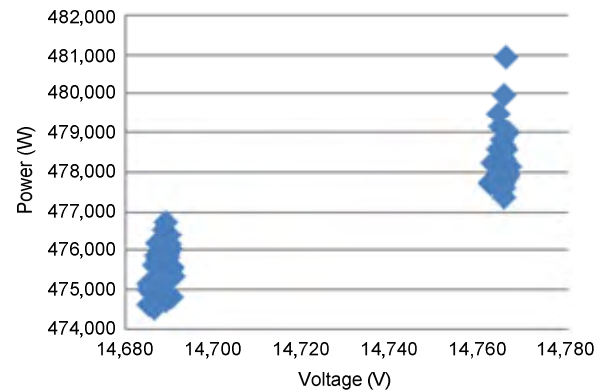

Fig. 6. Sample set of data points collected for a single  $K_p$  coefficient calculation

The data set under consideration included over 1,600 tap operations. The  $K_p$  from each of those operations averaged above 1, as shown in Table I. This means that, on average, there will be an immediate reduction in power demand when voltage reduction is enabled.

TABLE I  
AVERAGE  $K_p$  VALUE CALCULATED

| Substation | Phase A | Phase B | Phase C |
|------------|---------|---------|---------|
| 1          | 1.17    | 1.18    | 1.17    |
| 2          | 1.62    | 1.19    | 1.4     |

Because the load does not always exhibit the same characteristics,  $K_p$  will be very small at times, or even negative, while at other times, it will be relatively large. A negative  $K_p$  value occurs when a reduction in voltage corresponds with an increase in power or an increase in voltage corresponds with a reduction in power.

Fig. 7 shows the  $K_p$  coefficients obtained from 200 tap operations, and the results vary as described. Though most of them fall in the range between 1 and 2, there are some values that indicate there may be other factors involved, such as a sudden change in load unrelated to the tap change.

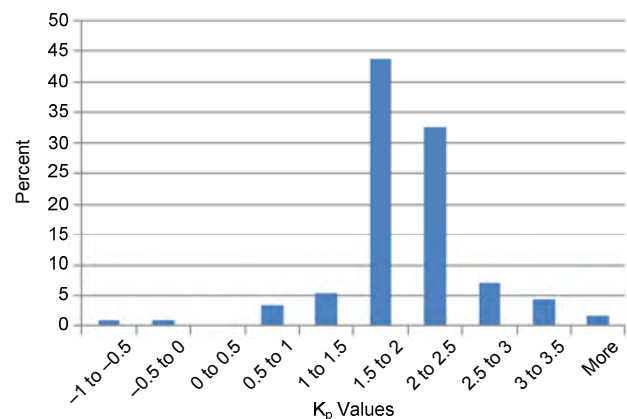

Fig. 7. Variation of the  $K_p$  coefficient for a feeder and 200 different tap operations

### B. Effect on Daily Demand

We could expect that if the initial reduction in voltage did indeed produce a reduction in demand, there could be some energy savings over the course of a day. However, the data did not support this conclusion. For the circuits under consideration, there was no statistical difference between the power consumed on the circuit on days with voltage reduction enabled and on days without voltage reduction.

To understand this, consider the short-term versus the long-term effects of voltage reduction on thermostatically controlled loads. For example, consider a neighborhood using resistive heaters, with each heater running 50 percent of the time. If voltage reduction is initiated at  $t = 0$ , how long would it be until 60 percent of the heaters would be running at the same time due to their decreased wattage at a lower voltage? Voltage reduction will adversely affect load diversity in the case of thermostatically controlled loads.

As shown in Table I, the  $K_p$  coefficients predicted that a voltage reduction would cause a reduction in power. But we see that this did not happen over the course of a day. The natural conclusion is that the  $K_p$  coefficient is only able to measure the short-term effect of voltage reduction. The question remains—what is the time frame of that short-term effect?

### C. Effect on Short-Term Demand

Next, we examined the effect of voltage reduction on the demand for a short period immediately after voltage reduction was initiated.

To quantify the demand reduction, we divided the day into 15-minute periods. We computed the average demand of each period for the days with CVR enabled and days with CVR disabled on both the feeder and substation. Because the substation contains several feeders and only one of them was under CVR, we assumed that the variation in the substation energy demand was not significantly affected by the CVR, so any difference between substation demand on the days with CVR enabled and days with CVR disabled was attributed to weather or customer usage patterns.

We used the simple ratio:

$$\frac{SD, \text{ no CVR}}{SD, \text{ with CVR}} = \frac{FD, \text{ no CVR}}{\text{Expected FD, with CVR}} \quad (11)$$

where:

SD is the substation demand.

FD is the feeder demand.

For example, assume the average substation demand for a day with CVR enabled is 10 percent higher than the average substation demand for a day with CVR disabled. Had we not enabled CVR on the feeder, we would expect that the feeder energy demand would also be 10 percent higher. Then we compare the estimated feeder demand with the actual feeder demand with CVR enabled to obtain the reduction in demand.

### 1) Substation #1

At Substation #1, the feeder demand was reduced an average of 2.2 percent for the first 5 hours when 3 percent voltage reduction was enabled. This would be enough time to benefit the system operator during peak load. Fig. 8 shows the reduction in demand for each 15-minute period.

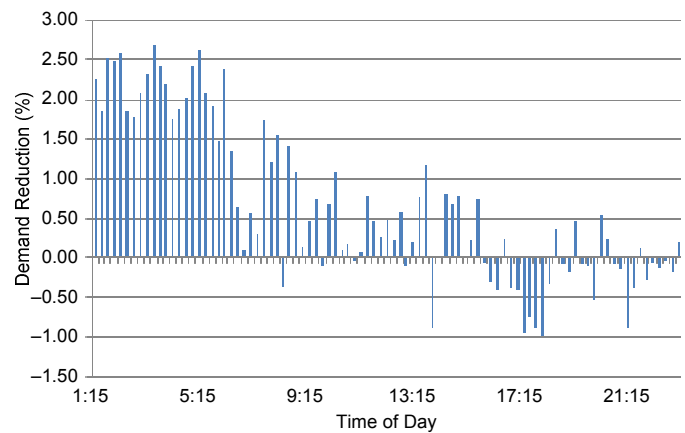

Fig. 8. Three percent demand reduction per 15 minutes at Substation #1

It is interesting to note that the reduction in demand was greatest for the first 5 hours, until the morning peak load. It is also interesting that for some time periods, the demand was increased with voltage reduction enabled, as indicated by the negative values in the chart.

With the commonly used equation for CVR factor, shown in (12), Substation #1 has a CVR factor of 0.73 for the first 5 hours. Each utility will have its own criterion to determine when the benefits of voltage reduction are enough to be worth implementing. With a CVR factor of 0.73, it could be worth implementing voltage reduction if there were little cost and risk involved.

$$\text{CVR factor} = \frac{\% \text{ demand reduction}}{\% \text{ voltage reduction}} \quad (12)$$

### 2) Substation #2

The effect of voltage reduction on short-term demand in Substation #2 was 0.5 percent for the first 1.75 hours when 3 percent voltage reduction was activated and an increase in demand when 2 percent voltage reduction was enabled. From preliminary experiments done at a large North American utility, it is theorized that the initial CVR factor experienced will depend on the time of day that voltage regulation is enabled. The load characteristics will vary throughout the day as customers turn lights and heat on and off. There is less lighting load in the middle of the night than in the middle of the day. Because some lighting types respond well to voltage reduction, the initial CVR factor may be more beneficial if voltage regulation is activated during the day instead of at 1:01 a.m., as done in this project. Considering this, a modification to this project is discussed later in this paper.

As shown in Table I, the  $K_p$  coefficients predicted about the same demand reduction from Substation #1 and Substation #2. We have just seen that these two substations respond very differently to voltage reduction. And though we may find a time in the day when Substation #2 will produce a positive initial CVR factor, at this point, that is a question that has yet to be answered.

#### D. PMU Data Stream Analysis

For the purpose of this project, a constant stream of PMU samples was saved to an external computer for further analysis. During data analysis, the varying nature of the load caught our attention. In some of the time periods, there were obvious power oscillations; in other time periods, there did not seem to be a pattern to the load changes.

The power oscillations shown in Fig. 9 have a frequency of 1 Hz and a magnitude of 6.7 kW on a base load of 816 kW, or 0.8 percent. In this context, the magnitude of oscillation is significant because a tap change on these voltage regulators only changes the voltage by 0.625 percent.

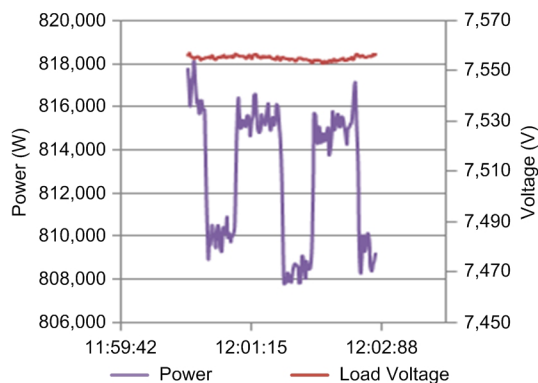

Fig. 9. Power oscillation during a steady-state voltage condition

The varying nature of the load makes it difficult to identify the step change in power that is due to a voltage tap change versus a change in power due to customer demand. If by chance the rapid change in power flow coincides with a tap change, it is necessary to remove the influence of the power change from any calculations. This is an area for further study and experimentation.

#### VI. CONCLUSION

The underlying concept of static load estimation is built on a mathematical model, and as such, there is much value in applying it to the task under consideration. However, the ability of this analysis algorithm to give utility engineers a single coefficient to characterize the loads on their system depends on the ability to characterize other aspects of the distribution circuit. The two main aspects that need to be further understood and characterized are the following:

- The length of time that voltage reduction reduces power demand.
- The short-term variability of the loads.

If the oscillatory load variations are regular enough to be characterized with a frequency and magnitude, then it is opined that they can be normalized so as to not influence the  $K_p$  coefficient calculation. As observed, the load does not always vary in a regular oscillatory manner, so it may not always be possible to normalize the variability out of the calculations. In these instances, it may be better to decline to calculate the  $K_p$  coefficient.

The following are two possible techniques to characterize the length of time that voltage reduction is beneficial:

- Model loads considering time of day, season of the year, ambient temperature, and effects of thermostats.
- Observe the response to the voltage reduction on a specific circuit at different times of the day and year, and draw conclusions from the data gathered.

#### VII. FUTURE WORK

While this project continues, there is more work that can and will be done in characterizing the loads and applying mathematical models to understand and predict their behavior. Along that line, we see the future of this project going in the following directions:

- To improve the quality of the  $K_p$  coefficient, we need to normalize the pre-condition and post-condition values in a way that removes the influences from power variations not caused by voltage step changes.
- To create a map of the short-term effect of voltage reduction at different times of the day, we will modify the daily start time of voltage reduction.

#### VIII. REFERENCES

- [1] B. W. Kennedy and R. H. Fletcher, "Conservation Voltage Reduction (CVR) at Snohomish County PUD," *IEEE Transactions on Power Systems*, Vol. 6, No. 3, pp. 986–998, August 1991.
- [2] D. M. Lauria, "Conservation Voltage Reduction (CVR) at Northeast Utilities," *IEEE Power Engineering Review*, Vol. PER-7, No. 10, pp. 58–59, October 1987.
- [3] T. L. Wilson, "Energy Conservation With Voltage Reduction – Fact or Fantasy," proceedings of the IEEE Rural Electric Power Conference, Colorado Springs, CO, May 2002.
- [4] D. Kirshner, "Implementation of Conservation Voltage Reduction at Commonwealth Edison," *IEEE Transactions on Power Systems*, Vol. 5, No. 4, pp. 1178–1182, November 1990.
- [5] IEEE Task Force on Load Representation for Dynamic Performance, "Standard Load Models for Power Flow and Dynamic Performance Simulation," *IEEE Transactions on Power Systems*, Vol. 10, No. 3, pp. 1302–1313, August 1995.
- [6] Global Energy Partners, LLC, "Distribution Efficiency Initiative: Market Progress Evaluation Report, No. 1," Report #E05-139, May 2005. Available: <http://neea.org>.



## IX. BIOGRAPHIES

**Greg Hataway** received his BS in Electrical Engineering from the University of Alabama in 1991. He has broad experience in the field of power system operations and protection. Upon graduating, he served nearly 12 years at Alabama Electric Cooperative, where he worked in distribution, transmission, and substation protection before assuming the role of superintendent of technical services. He joined Schweitzer Engineering Laboratories, Inc. (SEL) in 2002 as a field application engineer in the southeast region of the United States. After 8 years at SEL, he rejoined PowerSouth Energy Cooperative in 2010 as a division engineer in power delivery. Mr. Hataway has authored numerous technical papers and guides and is a member of the IEEE Power and Energy Society.

**Dallas Jacobsen** received a BS in Computer Engineering, magna cum laude, from the University of Washington in 2003. He worked as an electrical engineer for Puget Sound Energy in the power generation, system protection, and relay departments. In 2011, he joined Schweitzer Engineering Laboratories, Inc. as a lead power engineer in the research and development division. Mr. Jacobsen is a licensed professional engineer in Washington and a member of IEEE.

**Marcos Donolo** received his BSEE from Universidad Nacional de Río Cuarto, Argentina, in 2000, and his masters degree in electrical engineering (2002), his masters degree in mathematics (2005), and his Ph.D. in electrical engineering (2006) from the Virginia Polytechnic Institute and State University. Since 2006, he has been with Schweitzer Engineering Laboratories, Inc., where he is presently a lead research engineer. He is a member of IEEE.