

Enhance VFD Protection With the SEL-849 Motor Management Relay

Alan Saldivar

INTRODUCTION

Due to low operating cost, high performance, and energy savings, the use of variable frequency drives (VFDs) to control ac motors is increasing in all industrial markets. Vast quantities of VFDs are used in the continuous process industry environment. They provide process control as well as motor protection for ac motors of all sizes. This application note discusses how the SEL-849 Motor Management Relay, shown in Figure 1, enhances VFD protection and provides redundant backup control for VFD normal operation, malfunction, soft start bypass, maintenance, or replacement. This application note also addresses protection challenges, such as arc-flash mitigation in motor control centers (MCCs), fault recording capabilities (waveform capture), and motor start reports, that VFDs are not able to address.



Figure 1 SEL-849 Motor Management Relay

PROBLEM

The biggest challenge for continuous process industries is operating without any unscheduled interruptions. Any process in the oil, gas, petrochemical, water, wastewater, metals, or mining markets that involves heavy use of rotary machinery needs to have reliable monitoring, protection, and control devices. Even though most VFD manufacturers offer unique features such as component bypass, component redundancy, cooling capability, communications, and diagnostics, they cannot guarantee that their VFDs will not fail. From a reliability and risk standpoint, the need for a redundant device is evident. A VFD bypass is commonly used to ensure that the fans, pumps, compressors, and other equipment are kept running in an industrial plant even if the VFD is taken out of the control loop.

Both electronic and conventional bypasses are commonly used to take the VFD out of the control loop. This is concerning because the motor is only controlled by a VFD bypass contactor when there is no intelligent electronic device (IED) providing protection, monitoring, or control. This

automatically excludes the possibility of having any type of motor start report or waveform capture for motor data analysis during normal or abnormal operation.

Even though the VFD bypass fulfills the purpose of keeping the process running, an IED is needed to properly ensure the reliability and safety of the industrial process. Another evident challenge is the fact that VFDs are typically installed in MCCs. MCCs have a significant arc-flash hazard potential due to the large available fault current.

SEL SOLUTION

The SEL-849 provides complete motor protection for a low-voltage motor. One feature of the SEL-849 is that it can be applied to enhance VFD protection when the motor is running with the VFD or when the VFD is bypassed. Figure 2a shows a typical VFD bypass diagram where the SEL-849 is enhancing VFD protection and control as well as acting as a redundant protective device.

This SEL solution addresses the following three major applications of VFD bypass:

- Isolation of the VFD for maintenance while allowing the motor to operate directly across the line (scheduled interruption).
- Sharing one VFD among several motors for soft starting, as shown in Figure 2b. Once a motor is at full speed, it is switched to operate across the line (normal or common operation).
- Unexpected VFD failure (unscheduled interruption).

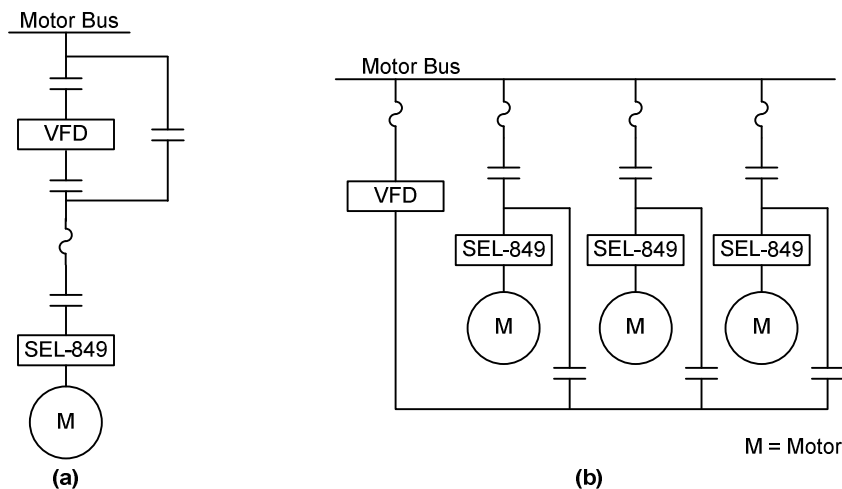

Figure 2 Typical VFD Bypass (a) and Shared VFD for Soft Start Bypass for Several Motors (b)

Even though the SEL-849 is able to support both VFD and VFD bypass operations, the following points need to be considered when VFD bypass mode is applied:

- The motor must be suitable for both VFD and across-the-line operation. Some inverter-duty motors are not approved for across-the-line operation.
- The motor and loads must be capable of continuous full-speed operation.
- Any reversing arrangements must be considered.

Figure 3 shows what a typical connection looks like for a VFD bypass configuration. It shows the connection diagram for factory default I/O assignments for the SEL-849 VFD motor application. This configuration allows the SEL-849 to go into bypass mode in case of an unexpected VFD

malfunction, scheduled maintenance, or a soft start configuration. Note that this is only one example of how the relay can be configured for VFD applications; some other configurations may be applied as well.

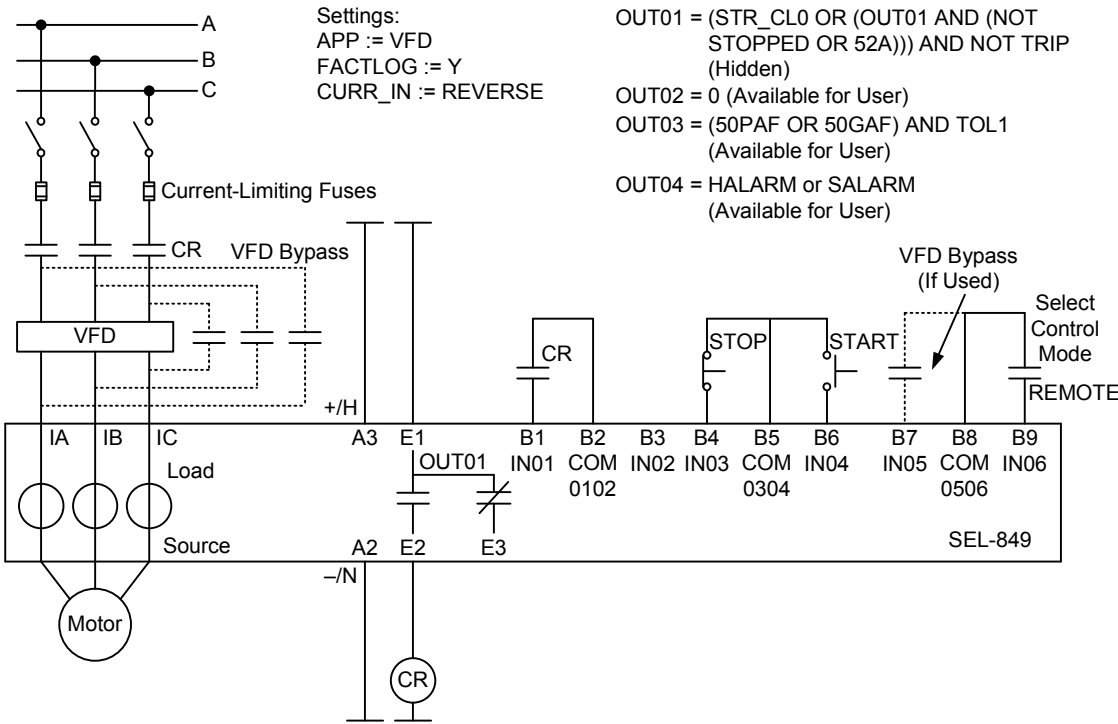

Figure 3 Connection Diagram for Factory Default I/O Assignments for Full-Voltage Nonreversing Starter With VFD

When the SEL-849 is using the VFD application setting, the relay uses root-mean-square (rms) current magnitudes instead of fundamental magnitudes for current-based protection elements. Once the system goes into VFD bypass mode, the relay automatically switches from rms to fundamental magnitudes of the currents for current-based protection elements.

During normal operation or bypass mode, the large available fault current in MCCs presents a potential arc-flash hazard. The safety of VFD-operated motors can be improved using the arc-flash protection element in the SEL-849. This element provides trip security during an arc-flash event by tripping only during a light and overcurrent condition. Figure 4 shows a typical configuration for arc-flash protection using the SEL-849. Refer to the SEL Application Note AN2013-09, available at <http://www.selinc.com>, for more details on arc-flash protection for MCCs.

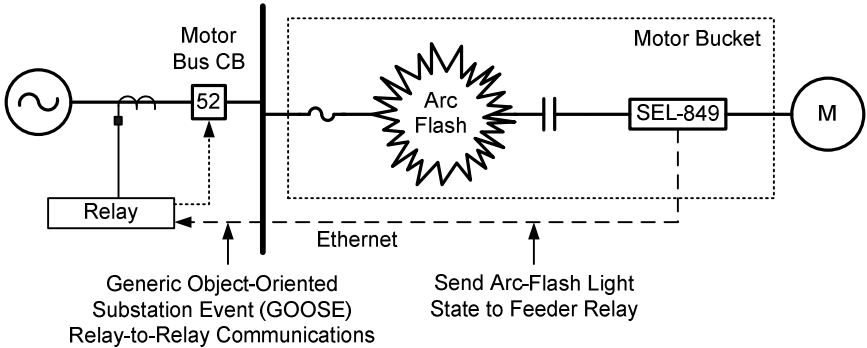

Figure 4 Relay-to-Relay GOOSE Messaging for Arc-Flash Protection

Two other crucial SEL-849 features that enhance VFD protection are waveform capture and motor start reports, as shown in Figure 5 and Figure 6. These features provide in-depth analysis of the motor behavior to identify any abnormal conditions.

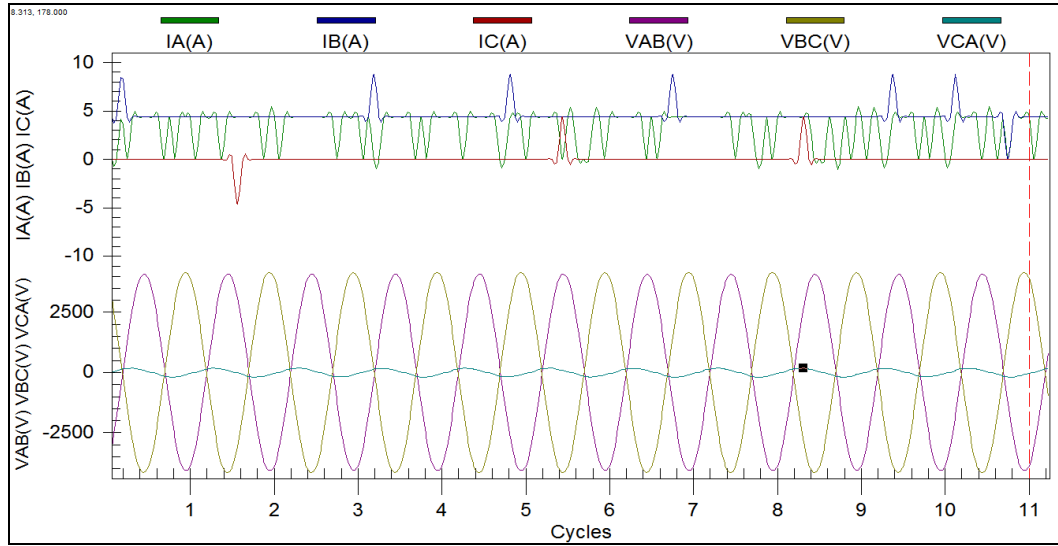

Figure 5 Waveform Capture Report

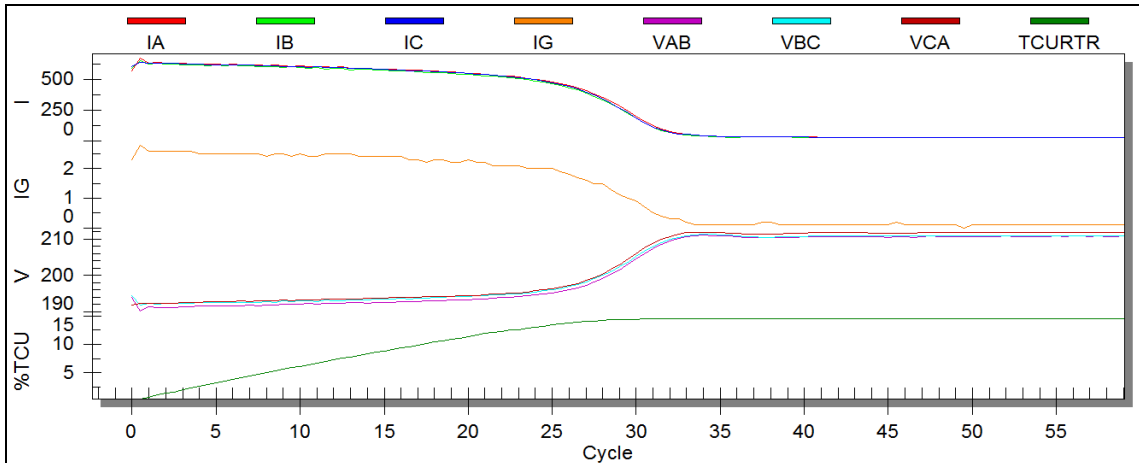

Figure 6 Motor Start Report