

A Precise Timing Solution for IEC 61850-Compliant Digital Secondary System Applications

Dustin Williams
Burns and McDonnell

David G. Williams
FirstEnergy

Motaz Elshafi
Schweitzer Engineering Laboratories, Inc.

Presented at the
UTC Telecom & Technology Conference 2026
Minneapolis, Minnesota
June 1–4, 2026

Originally presented at the
2025 Grid of the Future Symposium, November 2025

A Precise Timing Solution for IEC 61850-Compliant Digital Secondary System Applications

Dustin Williams, *Burns and McDonnell*

David G. Williams, *FirstEnergy*

Motaz Elshafi, *Schweitzer Engineering Laboratories, Inc.*

Abstract—Precise time is crucial for power system applications. Line current differential (87L) relays using the Sampled Values (SV) protocol traditionally depend on discrete Global Navigation Satellite System (GNSS) clocks at each substation. Process interface unit (PIU) devices sample alternating current (ac) quantities and generate SV frames with counters that align to the top of every second. For IEC 61850 substations leveraging SV, the algorithm compares locally acquired ac quantities against remotely acquired ac quantities from substations. Thus, PIUs require a common time reference. The most common applications for this requirement are 87L protection and phasor measurement unit (PMU) applications.

Utilities have grown dependent on GNSS reliability at each substation. If GNSS signals are lost, the algorithms relying upon it may become unavailable or misoperate. Redundant GNSS clocks are still susceptible to interference, spoofing, and jamming. However, modern timing technologies can mitigate disruptions to the GNSS.

The authors designed and tested a system to mitigate issues from GNSS outages. We validated a solution using enhanced primary reference time clocks (ePRTC) and time distribution gateways (TDGs). The TDG network references IEEE 1588 PTP ITU-T G.8275.1 from the ePRTC through a timing-aware telecom network. The solution maintains time accuracy after losing GNSS signals and demonstrates the survivability of substation functions dependent upon time synchronization used for the SV protocol. Protective relay data demonstrate that this solution provides utility-wide synchronization in the loss of GNSS signals for classic utility relaying and IEC 61850-compliant digital secondary systems.

Keywords—IEC 61850, Sampled Values (SV), Process Interface Units (PIUs), Line Differential Protection (87L), Global Navigation Satellite System (GNSS), IEEE 1588 Precision Time Protocol (PTP), Time Distribution Gateway (TDG), Telecom, Enhanced Primary Reference Time Clock (ePRTC)

I. INTRODUCTION

Traditional substation protective relays have electrical circuitry that connects to yard instrument transformers using copper cables for current and voltage measurement. Substations using IEC 61850 process bus technologies have process interface units (PIUs) installed in the yard near the primary equipment that is connected to instrument transformers. PIUs perform analogue-to-digital conversion, and the resulting samples are published over an Ethernet network via Sampled Values (SV) to subscribing devices inside the substation control enclosure, such as protective relays. Since the PIUs are not all controlled by a common processor, they must time-stamp their converted digital samples so subscribing devices can time-align the measurements before performing calculations. This is done

with a sample counter (SmpCnt) that resets at the beginning of each second. In this paper, the term IEDs refers to PIUs and protective relays.

For protection algorithms using only local, site-based measurements, local time synchronization between local PIUs is sufficient, without requiring time traceability using a global reference. However, for protection algorithms using both local and remote substation measurements, globally traceable time synchronization between substations is required. Both local and traceable time synchronization leverage discrete Global Navigation Satellite System (GNSS) clocks installed at each substation. The redundancy of these GNSS clocks can improve availability, but GNSS receivers are still susceptible to interference, spoofing, and jamming. Thus, having alternative methods of distributing time through the system is key; hence, the need for a terrestrial time distribution model.

When discrete clocks produce traceable time, SV frames can be used to compare locally acquired ac quantities against remotely acquired ac quantities from substations. If GNSS signals degrade or are lost at one or more sites, SV frames indicate that synchronization has dropped from global to local, wherein the discrete clock is operating in holdover mode. After the holdover window expires and exceeds specifications, the SV frames show that time accuracy drops from local to unsynchronized, and algorithms, e.g., 87L and phasor measurement unit (PMU), using data from multiple sites no longer function.

A key power system application is 87L protection, which is based upon the concept that current cannot simply vanish. If protective relays are installed to measure all connections of a transmission line to the rest of the power system, the sum of the current into the line through those connections should be close to the sum of current out of the line, under normal conditions. Another way to say this is that the amount of current entering the line minus the current leaving the line is close to zero. If a fault occurs on that line so the current can now flow out of the line in an undesired location, more current will be measured entering the line than leaving it. When this non-zero value is encountered, the protective relays initiate tripping of the circuit breakers to disconnect the faulted line from the rest of the power system.

Protective relays performing 87L protection functions can either be hardwired to instrument transformers or subscribe to SV streams. Since the terminals of the transmission line are spread over a large geographic area, protective relays installed

at each terminal must communicate digitally with each other to share their current measurements, allowing one or more of the devices to perform the differential calculation. These distributed current measurements must be time-aligned with each other before the calculation for an accurate result, since the current passing through each line terminal changes continuously.

Different methods exist for handling the time-alignment of 87L measurements. While some methods measure communications delays and use that information to apply offsets to remote measurements (known as the ping-pong method), others rely on including measurement time stamps as part of the data stream. The use of time stamping requires high-accuracy time synchronization at all line terminals. Any time error in these time stamps directly introduces error in the differential calculations.

While the use of GNSS-enabled discrete clocks provides time with the accuracy necessary to implement SV and 87L applications, FirstEnergy, an electric utility in the United States, was worried about total reliance on GNSS alone and the degradation of system performance during a corner case of wide-area, prolonged GNSS signal disruption. The utility's use case involved processing SV data from multiple sites where time discrepancies lead to undesirable outcomes. This problem led to an exploration of various technologies to prevent time discrepancies from occurring.

II. TIME DISTRIBUTION USING PRECISION TIME PROTOCOL (PTP)

A typical IEC 61850 digital secondary system uses PTP based on the IEEE 1588 version 2 standard to synchronize IEDs at a local substation. PTP is also used in telecom networks for wide-area time distribution. PTP is a protocol used to distribute time across a packet-switched network (PSN), and different profiles exist to support various use cases. These profiles provide guidelines for interoperability among device manufacturers.

IEEE and IEC define PTP profiles used for substation local-area networks. The utility plans on using the IEC 61850-9-3 power utility profile in its substations. The International Telecommunication Union (ITU) establishes different PTP *telecom* profiles. The ITU's PTP profiles are designed for wide-area networks (WANs). The utility's solution explores a specific PTP telecom profile, namely ITU-T G.8275.1, carried over an existing WAN.

PTP relies on one or more grandmaster (GM) clocks to obtain UTC time from satellite sources and act as terrestrial time references. To mitigate GNSS jamming and spoofing risks, telecom network architects place GM clocks in secure, strategically located sites with broad geographic coverage interconnected via a PSN and leverage PTP telecom profiles to distribute precise time across the PSN. PTP frames generated by the GM clock contain two key attributes: clock class and clock accuracy.

Clock class indicates the current GNSS lock status. PTP telecom and power utility profiles define two significant values: 6 and 7. A clock class of 6 signifies synchronization with a

primary reference time source (PRTC), such as GNSS, rather than another clock in the network. A class of 7 means the clock was previously locked to a PRTC but has since transitioned into holdover mode.

The clock accuracy attribute reflects how precisely a clock's output aligns with UTC. When GNSS signals are available, the clock maintains its best accuracy. However, if GNSS connectivity is lost and the clock enters holdover, accuracy gradually deteriorates until satellite synchronization is restored. The rate of degradation depends on the quality of the oscillator used for GM holdover. For instance, a typical oven-controlled crystal oscillator (OCXO) degrades quicker than a rubidium (Rb) oscillator.

Transparent clocks (TCs) and boundary clocks (BCs) are specialized devices in the PSN that distribute PTP received from a GM clock to downstream-connected applications. TCs transparently pass along PTP frames and perform corrections to compensate for packet residence time. BCs operate slightly differently than TCs in that they are receivers of PTP from upstream clocks and take on the GM role as they transmit PTP to downstream devices.

End devices are called ordinary clocks (OCs) or timeReceivers. When there are multiple upstream GM clocks connected to the same network, GM clocks, BCs, and OCs use a best timeTransmitter clock algorithm (BTCA) to determine which PTP reference is superior. With the help of BTCA, the superior GM clock is defined according to many criteria, including, but not limited to, the source with the best clock class and clock accuracy. The best GM clock is then selected as a time reference.

For further details, refer to the IEEE 1588 v2 standard [1] and the ITU-T G.8275.1 recommendation [2].

The PTP profiles are not directly interoperable and thus require devices, e.g., time distribution gateways (TDGs), to help convert between the profiles.

III. TDG NETWORK

The next technology explored for the utility's solution was the use of TDGs. A TDG is a commercially available device designed to provide additional time sources into a substation, enabling critical infrastructure to transition from relying solely on satellite-based time references to a hybrid approach incorporating both satellite and PSN time sources. Previous research explores the deployment of a TDG that supports both satellite and terrestrial timing for critical networks [3] [4].

One of the key benefits of a TDG is its ability to mitigate localized GNSS signal disruptions. A TDG receives highly accurate time by accessing signals directly using built-in GNSS receivers. A TDG can also synchronize to an existing substation clock via IRIG-B. If interconnected over a PSN, a TDG can use the PTP telecom profile as a time input. Depending on site-specific time source availability, a TDG can synchronize to one, or even multiple, GNSS, IRIG-B, and PTP telecom profile sources.

When multiple TDGs are deployed, they can form a TDG network capable of distributing precise time in a format compatible with most substation IEDs. This network supplies

accurate timing to critical applications using IRIG-B or the PTP power profile. By combining satellite and terrestrial time sources, this architecture enhances resilience against potential positioning, navigation, and timing disruptions, making it a hybrid timing model.

The uniqueness of the TDG solution outlined in [3] lies in its ability to coordinate system time across multiple TDGs and leverage the weighted average system time to convert a PTP telecom profile to a profile used by IEDs. Unlike a single gateway performing a basic time format conversion, this approach enhances accuracy by leveraging time inputs across multiple networked TDGs. The system time is then distributed to connected IEDs. The TDG network alone can protect against an attacker tampering with GNSS signals at a given site.

IV. TELECOM NETWORK

A third technology explored for the utility's solution was telecommunications networks. Telecommunications are taking on an increasingly critical role in modern utility networks. Beyond providing IP backhaul for essential control and monitoring systems, they are increasingly depended on for precise time synchronization across the digital landscape. Applications such as teleprotection and legacy time division multiplexing-based circuit emulation demand submicrosecond accuracy to function reliably.

This demand only intensifies as utilities embrace IEC 61850 standards, especially with the deployment of PIUs and SV within the substation environment. These technologies shift more intelligence and data processing to the edge of the grid, but they also raise the stakes for timing accuracy. A loss or drift in time synchronization can directly affect the performance and safety of grid operations.

The utility examined various strategies for distributing accurate time across the network and explored how different architectures, whether centralized, hybrid, or fully distributed, could deliver the robust, scalable, and precise timing infrastructure needed to support modern and future utility applications.

The first architecture under consideration was a TDG-only network. In this configuration, each TDG is interconnected with other TDGs via fiber-optic cabling, forming a dedicated timing distribution backbone. The core timing sources for the network, typically one or more GM clocks, are directly interfaced with one or more TDGs, which act as the aggregation and distribution points for precise time synchronization. The GM clocks are enhanced primary reference time clocks (ePRTCs) with Cesium (Cs) atomic references.

This design supplements or minimizes reliance on traditional satellite-based timing at the substation level, instead using the TDG infrastructure to propagate time signals throughout the network. The fiber interconnects between TDGs support high-precision timing protocols, such as the PTP telecom profile defined in ITU-T G.8275.1, providing minimal latency and high accuracy in time dissemination.

Once synchronized, each TDG can deliver the PTP power utility profile into the local substation environment. This enables accurate synchronization of critical infrastructure devices, such as IEDs, protective relays, and automation controllers, that require deterministic and reliable timing for operation, event logging, and coordination.

This architecture is particularly suited for utility and industrial applications where a centralized, fiber-based timing infrastructure can offer improved security, redundancy, and resilience compared to GNSS-dependent systems. An illustration of a TDG-only network is depicted in Fig. 1.

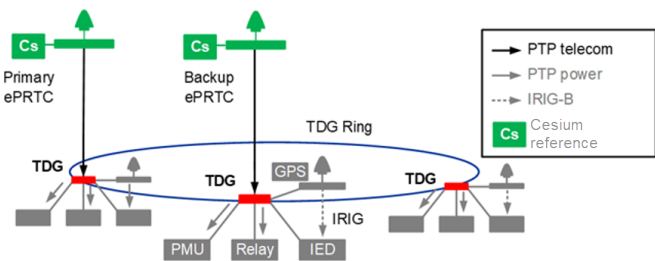

Fig. 1 TDG-Only Network

The second architecture considered leveraged a dual-layer, single-purpose network approach, in which time distribution and data transport are handled by two interconnected but purpose-specific infrastructures. In this design, the GM function is integrated directly into a routed WAN, such as a Multiprotocol Label Switching (MPLS) network. This telecommunications backbone is built entirely on single-mode fiber and organized in a mesh topology, providing high availability, redundant routing paths, and low-latency communications between core network elements.

Parallel to the MPLS network, a dedicated TDG network, also using fiber, is established but structured in a ring topology. The ring design provides built-in resilience by allowing bidirectional time flow, enabling the network to maintain timing continuity even in the event of a fiber break or node failure.

In this architecture, the telecommunications network is not responsible for delivering time to end devices. Instead, it connects to one or more strategically placed TDGs, which act as ingress points where precise time from the GM clocks is received. The TDG network then assumes the role of distributing a PTP telecom profile (specifically IEEE 1588 PTP ITU-T G.8275.1) to other TDGs within its topology. From there, power utility profile time is disseminated downstream to substation devices requiring accurate synchronization, such as protective relays, SCADA systems, and other IEDs.

This model offers a clean separation of responsibilities: the routed MPLS network serves high-bandwidth communications and time source delivery, while the TDG network provides deterministic, low-jitter time propagation tailored for mission-critical infrastructure. It also offers scalability, as additional TDGs can be added to the ring to expand coverage without impacting the core MPLS topology. An illustration of a dual-layer, single-purpose network is depicted in Fig. 2.

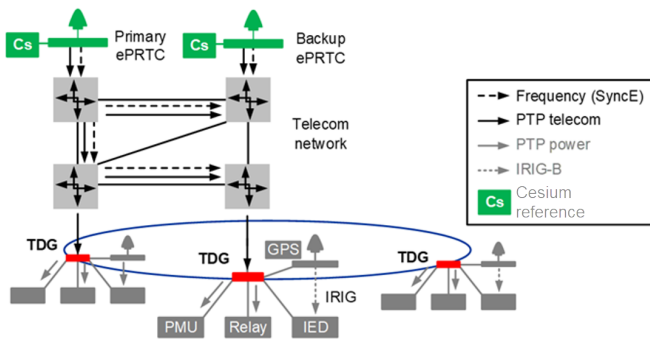

Fig. 2 Dual-Layer, Single-Purpose Network

The third architecture considered was a dual-purpose network, in which the telecommunications and timing functions are served by a common routed infrastructure, typically an MPLS-based network, while the TDG network itself does not use dedicated fiber interconnects. In this model, the MPLS network, built on single-mode fiber and designed in a mesh topology, serves both as the primary data transport backbone and as the medium for distributing precise time from one or more GM clocks.

In this architecture, the TDGs are directly connected to MPLS-enabled network nodes. These TDGs do not rely on their own dedicated fiber ring or mesh but, instead, receive time over the routed MPLS infrastructure using the IEEE 1588 PTP operating in multicast mode.

Because the TDGs receive time from the MPLS domain, the accuracy and stability of time delivery are dependent on several factors within the telecommunications network, including router and switch PTP support, BC or TC capabilities, and proper configuration of timing-related quality-of-service policies to minimize packet delay variation and asymmetry.

Once synchronized, each TDG can provide precise time, often using the power utility profile, downstream to substation assets that depend on high-accuracy synchronization. However, since the TDG network is not interconnected via dedicated fiber, there is no separate timing backbone or redundancy path within the TDG layer itself. Each TDG operates independently and relies entirely on the integrity and timing distribution quality of the MPLS network.

This dual-purpose model simplifies infrastructure by converging timing and communications into a single network, reducing fiber installation and maintenance costs. However, it also introduces additional considerations around traffic engineering, clock hierarchy planning, and PTP-aware network device support to provide reliable time delivery. An illustration of a dual-purpose network is depicted in Fig. 3.

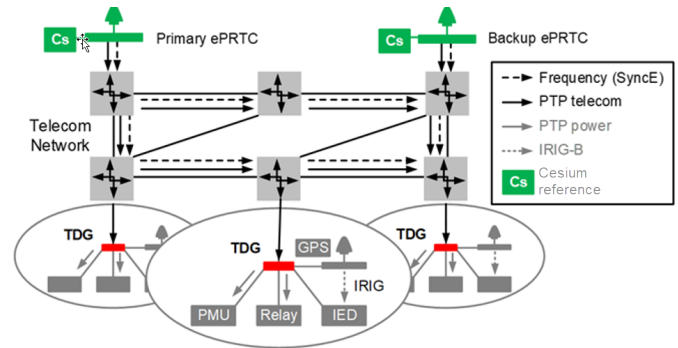

Fig. 3 Dual-Purpose Network

V. EPRTC TECHNOLOGY

The final technology explored for the utility's solution was an ePRTC. Network architects are increasingly considering ePRTC technology, as it provides high-accuracy time distribution during prolonged GNSS unavailability of 14 or more days [4]. The ePRTC technology is compliant with ITU-T recommendation G.8272.1 and combines time data from GNSS with frequency from an ITU-T G.811.1-compliant enhanced primary reference clock (ePRC).

An ePRTC solution is composed of the following components:

- ePRTC-capable clock
- Cesium (Cs) atomic clock used as a frequency reference
- GNSS antenna, cabling, and splitters

An illustration of an ePRTC is depicted in Fig. 4.

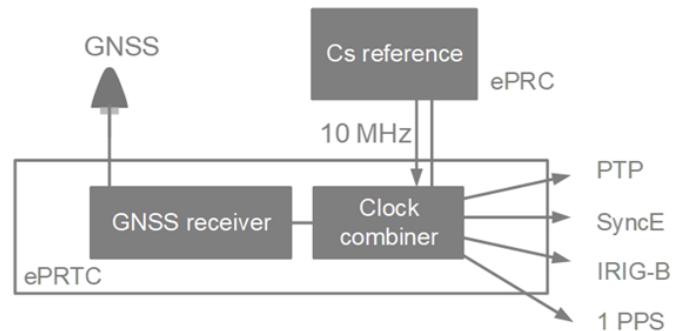

Fig. 4 Illustration of an ePRTC

An ePRTC solution offers two key advantages:

1. High accuracy with GNSS availability: When GNSS is available, ePRTC-based PTP time distribution typically achieves accuracy within 30 nanoseconds [4].
2. High accuracy during a GNSS outage: During an outage, the ePRTC maintains high-accuracy time output for extended durations. ePRTC manufacturer implementations vary on how to indicate a GNSS outage within the PTP frames. One manufacturer's GM clock produces PTP frames that mask the loss of the GNSS signal and maintain a clock class of 6 so that downstream network devices and applications remain unaware of the GNSS outage [4]. Another manufacturer's GM clock produces PTP frames that

change the clock class to 7 (holdover) upon loss of GNSS. Both products maintain high clock accuracy time upon the loss of GNSS.

In summary, ePRTC technology provides a robust and reliable solution for maintaining precise time synchronization in critical infrastructure, ensuring continued operation even during extended GNSS outages. The use of a Cs atomic clock as a supplemental reference enhances the system's resilience and accuracy.

VI. COMBINE TECHNOLOGIES TO FORM A SOLUTION

The utility decided to implement a solution wherein highly accurate, terrestrially distributed time from ePRTC sources is transported through a dual-layer, single-purpose telecom network and a TDG network to all critical sites. The TDGs supplement existing discrete clocks at the IED sites. A backup terrestrial time source ensures traceable time availability should a GNSS disruption impact one or more sites.

The ePRTCs are installed in secure, centralized locations. They serve as GM clocks that provide the PTP telecom profile through the telecom network. The telecom network supplies the PTP telecom profile to a TDG network with connectivity across all critical sites. The TDGs perform the PTP profile conversion from telecom to power utility profile using the weighted average scheme.

BCs and OCs use the BTCA to determine which PTP reference is superior. Time from the TDG network is compared to time received from the local GNSS clocks. Maintaining local, discrete clocks is key should there be any outages due to communications disruptions impacting time distribution from the ePRTCs. Reasons for these disruptions may include network replacements and upgrades, fiber-optic re-cabling, etc.

If the utility's solution was to be implemented at scale, it must be robust enough to deal with a system-wide GNSS

outage. The utility determined that the solution required lab validation prior to field implementation.

VII. TEST RESULTS

The utility built a solution validation lab comprised of ePRTCs, a partially connected telecom network, a TDG network, and TCs to feed precise time to substation IEDs. Fig. 5 depicts the lab connectivity.

Site 2 was the control. It received precise time from a discrete GNSS clock that maintained access to GNSS signals throughout the test. A standalone clock provided a PTP power utility profile through the TC to a PIU and a protective relay. The PIU and relay remained globally synchronized for the entire test.

Site 3 was the site under test. The utility built a communications network to distribute ePRTC time to a PIU and a protective relay at Site 3. The ePRTC, telecom network, and TDG ultimately provided the PTP power utility profile through a TC to a PIU and a relay. The utility expected Site 3 to function flawlessly during a 14-day ePRTC holdover period during which GNSS signals were lost. To confirm ePRTC performance, a GNSS synchronized test set was used to measure PTP time error.

Upon simulating a GNSS outage to the ePRTC that fed Site 3, the results were clear. The ePRTC system holdover maintained sub-100 nanosecond accuracy to UTC for 14 days. The SV frames at Site 3 and the 87L application with Sites 2 and 3 experienced no errors or interruptions. Fig. 6 illustrates the voltage angle difference using SV data analyzed from the PIUs at Sites 2 and 3. The y-axis is angle difference in degrees, and the x-axis is absolute time. We observed almost the same voltage from the SV data as was produced by our injection test set. As soon as the accurate time reference is lost at the end of the 14-day ePRTC holdover period, the voltage angles drift apart.

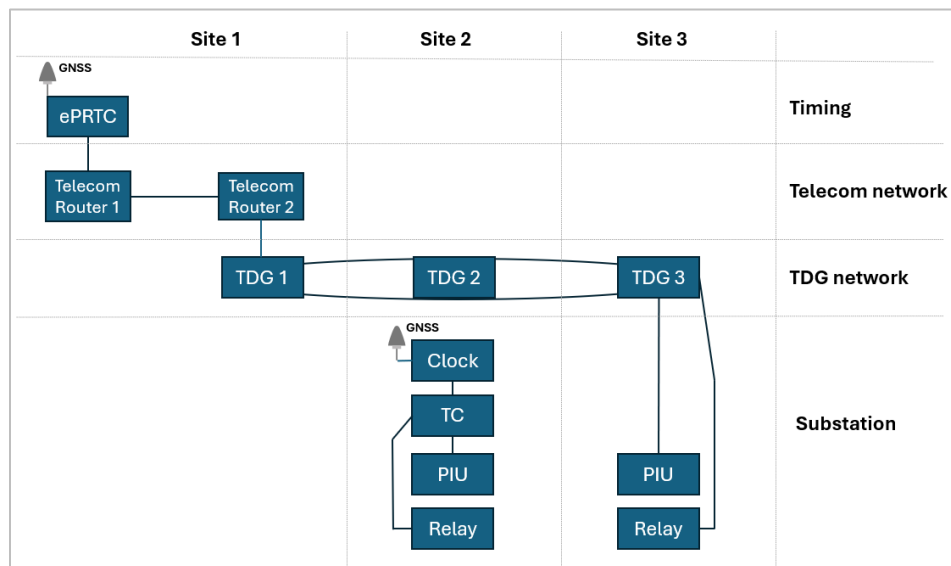

Fig. 5 Connectivity of Solution Validation Lab

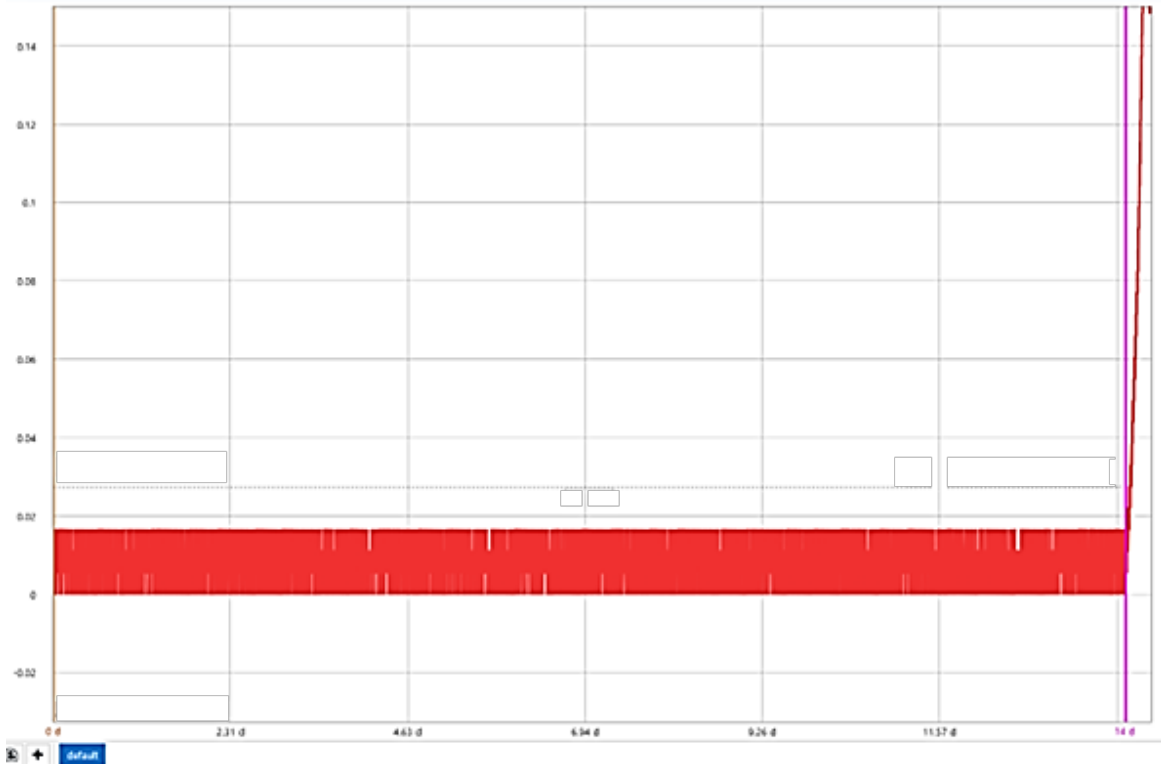

Fig. 6 Voltage Angle Difference Plot Using SV Data From PIUs at Sites 2 and 3

VIII. CONCLUSION

Validation proved that the combined ePRTC, telecom, and TDG network solution operated error-free with the loss of GNSS for 14 days with the same performance as if the GNSS signals were available and stable. FirstEnergy has a production telecom network today that uses the PTP telecom profile for time synchronization. Work is underway to deploy redundant ePRTCs for this network. The utility also has a TDG direct-fiber solution deployed for intersubstation protection communications, operating independently of the telecom network. In some instances, the TDG solution devices are already deployed at the same location as telecom network routers, but there is no PTP interface in place today between these devices.

FirstEnergy's Center for Advanced Energy Technology (CAET) [5] provides space for exploring innovative technology in support of the power grid. Part of this exploration involved the creation of a lab equipped with substation protection equipment capable of using IEC 61850 process bus protocols, including GOOSE, SV, and PTP. The installation was located in the Development Area that includes a telecom network, TDG networks, and one ePRTC.

This physical proximity allowed for testing a dual-layer, single-purpose telecom network providing the PTP telecom profile (specifically ITU-T G.8275.1) to TDGs in a native ring design, feeding the PTP power utility profile (IEC 61850-9-3) to substation IEDs for the SV application. This solution was motivated by the dependence of SV on time synchronization, though there are other applications dependent upon time synchronization, as discussed. Testing was pursued to allay concerns of GNSS dependence. As part of future work for

monitoring assets, FirstEnergy wants to be able to process native SV data from multiple sites, which further motivates the need for companywide coherent precise time distribution.

IX. REFERENCES

- [1] IEEE Std 1588-2019, IEEE Standard for a Precision Clock Synchronization Protocol for Networked Measurement and Control Systems. Available: standards.ieee.org/ieee/1588/6825/.
- [2] ITU-T G.8275.1: Precision Time Protocol Telecom Profile for Phase/Time Synchronization With Full Timing Support from the Network. Available: itu.int/rec/T-REC-G.8275.1/en.
- [3] D. Williams, M. Elshafi, K. Fodero, C. Huntley, and P. Robertson, "Using Wide-Area Precise Time Distribution to Increase Dependability and Security of Substation Time Synchronization," presented at the 75th Annual Conference for Protective Relay Engineers, College Station, TX, March 2022.
- [4] D. Williams, R. Jodrie, K. Fodero, P. Robertson, C. Huntley, and M. Elshafi, "Maintaining Precise Time for Power System Applications in the Event of Wide Area Loss of GPS," presented at the Protection, Automation & Control World Conference, Raleigh, NC, USA, Aug. 2023.
- [5] FirstEnergy, "Inside FirstEnergy's Center for Advanced Energy Technology," May 2019. Available: utc.org/wp-content/uploads/2018/02/CAET-brochure_2019-05-31-Finalized.pdf.