

# SEL Arc-Flash Detection (AFD)

Questions and Answers



# Contents

## Arc-Flash Basics

What is an arc-flash hazard? .....	4
What causes an arc flash?.....	4
What elements must be present for an arc-flash event to occur? .....	4
How does a protective relay help mitigate incident energy from an arc-flash event? .....	4
What role do air gaps play in an arc flash? .....	4
Are there other dangers in an arc-flash event besides intense heat and light?.....	5
How much light is produced in an arc flash?.....	5
How is the current determined in an arc-flash event? .....	5
How does SEL arc-flash technology mitigate arc-flash hazards?.....	5
How does SEL sensor-based AFD technology work? .....	5

## Configuration

How is arc-flash mitigation configured with SEL protective relays? .....	6
What is the maximum number of arc-flash sensors I can connect to an SEL relay?.....	6

## Light Sensors

Why do I need light sensors? Isn't the overcurrent element in a protective relay sufficient to sense when an arc-flash event occurs?.....	6
Which products represent the SEL family of sensor-based AFD products? .....	6
How does the SEL light-sensing technology work?.....	7
How do I know that the arc-flash-sensing technology will continue to work over time? Do I test the sensors periodically to verify that they're working? .....	7
How do I test the arc-flash sensors during commissioning to verify that they're in working order? ...	7
When should I use the bare-fiber sensor vs. the point sensor? Can I mix and match them on the same relay?.....	7
Has there ever been an arc-flash event where the arc-flash sensors were destroyed before they signaled the relay?.....	8
Does SEL sell or provide the necessary tools to cut and install arc-flash fiber-optic cabling? .....	8
Where do you recommend placing the arc-flash sensors in the switchgear?.....	8
Are SEL light sensors vulnerable to dust? .....	8
How does SEL recommend adjusting the sensitivity of the sensors? .....	8

## Technology

If the relay sees the fault current, why does it need the light sensor to trip faster? .....	9
Does the overcurrent supervision that SEL uses slow down the AFD speed? .....	9
If the switchgear is exposed to a light source, such as a camera flash, would that trigger the SEL protective relay to trip? .....	9
What if only an overcurrent condition were to occur? .....	9

## Arc Flashes in Motor Control Centers (MCCs)

Is AFD needed for low-voltage MCCs? .....	9
What communications were used in SEL arc-flash testing for an MCC? .....	10
How is the arc flash mitigated inside of an MCC bucket? .....	10

## Other Mitigation Technologies

What other types of arc-flash mitigation are available in addition to SEL's combination of light-sensing detection and overcurrent supervision? .....	10
Is maintenance switching sufficient to mitigate against arc flashes, or is more required? .....	10
If we have arc-resistant switchgear in place, is arc-flash mitigation via protective relays really necessary? .....	10

## Personal Protective Equipment (PPE)

Should a worker rely on AFD when selecting PPE, or is it for equipment protection only? .....	11
How can SEL show it is safe to reduce the PPE category? .....	11

## Resources

Where can I get more information? .....	11
---	----

# Arc-Flash Basics

## What is an arc-flash hazard?

According to the *National Fire Protection Association (NFPA) 70E: Standard for Electrical Safety in the Workplace*, an arc-flash hazard is “a source of possible injury or damage to health associated with the release of energy caused by an electrical arc.” In an arc-flash event, a flashover of electric current leaves its intended path and travels through the air from one conductor to another or to ground. During such an event, the air gets sufficiently heated to become ionized; the air becomes the conductor.

Arc-flash events can cause dangerous and potentially fatal heat, ultraviolet radiation, blast pressure, and flying shrapnel along with deafening sound waves. The resulting release of arc-flash energy, referred to as “incident energy,” is a measure of thermal energy at a working distance from an arc fault.

## What causes an arc flash?

Arc-flash events can be caused by numerous factors, such as the shorting of two phases, which creates a phase-to-phase fault. Common causes of phase-to-phase faults include dropped tools, accidental contact by maintenance personnel, the buildup of corrosion or conductive dust on conductors, and the presence of pests, like mice, rats, or snakes, that come in contact with energized conductors.

## What elements must be present for an arc-flash event to occur?

1. Air gap from using air as an insulator or from a damaged insulator.
2. Sufficient energy (fault current available from the power source) to initiate and sustain the arc-flash event. This is normally satisfied in low-voltage (480 V and above) and medium-voltage switchgear environments.
3. Something to trigger the arc flash. This could be a rodent, acting as a conductor across the phase conductors, or one of the causes listed above.

## How does a protective relay help mitigate incident energy from an arc-flash event?

The faster the extinction of the arc-flash event, the smaller the amount of incident energy that is released. Since arc-flash energy is proportional to voltage multiplied by current multiplied by time ( $V \cdot I \cdot t$ ), the protective relay acts to reduce the duration of the arc-flash event, or “t.” In an arc-flash event, this equals the time elapsed before the relay trips plus the breaker clearing time.

Relays don’t have any control over the voltage and current. The voltage across an arc is determined by the conductor gap; the arcing current is limited by the available fault current. What the relay can impact is time. By limiting the duration of the arc-flash event, the relay can dramatically reduce the amount of incident energy produced by an arc-flash event.

## What role do air gaps play in an arc flash?

While air is a good electrical insulator under normal conditions, if the air gets heated up and becomes ionized, that air will become a conductor, resulting in an arc-flash event. In environments with air gaps, such as electrical switchgear, arc-flash hazards exist with exposed copper or aluminum conductors; e.g., a busbar, contacts on the motor contactor, or breaker contacts.

## Are there other dangers in an arc-flash event besides intense heat and light?

High-voltage arcs can also produce considerable pressure waves by rapidly heating the air and creating a blast. This pressure blast can hit a worker with great force and send molten metal droplets from melted copper and aluminum electrical components great distances at extremely high velocities.

## How much light is produced in an arc flash?

In a very small (2,000 A) arc-flash event, the measured light intensity can be 2,000,000 lux, or twenty times brighter than bright sunlight, at a distance of 1 meter from the arc-flash source. For more realistic arcing currents (e.g., 17,000 A), we have recorded arc-flash light intensities of 12,000,000 lux. This is equivalent to the amount of light generated by 120 suns in the sky at one time.

## How is the current determined in an arc-flash event?

In medium-voltage equipment, the arcing current is slightly less than the bolted fault current in most cases (~90 percent). In low-voltage equipment (e.g., 480 V) the arcing current is about 60 percent of the bolted fault current. IEEE 1584 includes an equation for calculating the arcing current.

# Solutions Overview

## How does SEL arc-flash technology mitigate arc-flash hazards?

SEL AFD technology significantly decreases the time it takes a relay to trip in response to an arc fault, which reduces hazardous arc-flash incident energy. SEL combines light-sensing technology with fast overcurrent protection to provide secure high-speed AFD. Combining these technologies allows high-speed tripping during arc-flash events without unintentional tripping for external faults.

## How does SEL sensor-based AFD technology work?

Just after a fault current begins, the arc flash produces a very bright flash of light. The relay uses point sensors and/or bare-fiber sensors to detect the intense light. The overcurrent protection makes sure the relay does not trip for other sources of light, while the light sensors ensure the relay does not trip for an external fault.

Bare-fiber sensors detect light from the arc flash over the entire length of the fiber loop. This type of sensor is used for large areas, such as busbars.



Easily mounted point sensors detect light from the arc flash. This type of sensor is used for confined areas, such as breaker compartments.

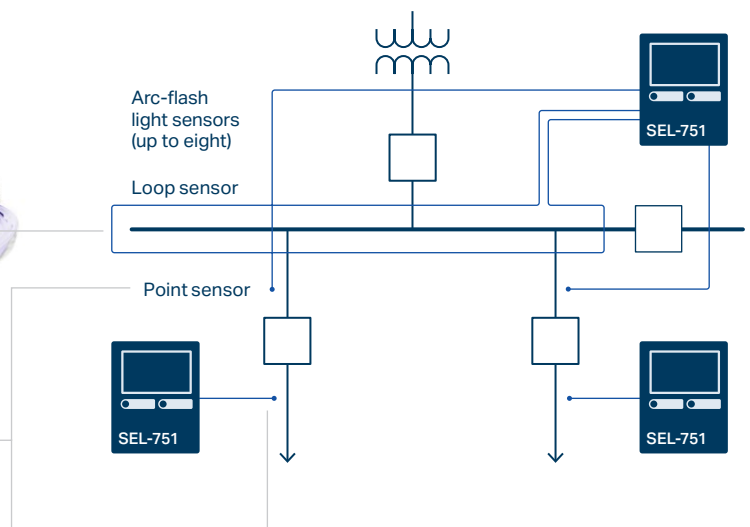

Which products represent the SEL family of sensor-based AFD products?



## Configuration

How is arc-flash mitigation configured with SEL protective relays?

Arc-flash mitigation is available as an optional arc-flash card with the SEL-751 and SEL-751A Feeder Protection Relays, the SEL-710-5 Motor Protection Relay, the SEL-787L Line Current Differential Relay, and the SEL-787Z High-Impedance Differential Relay. You can order it factory-installed with new SEL-700 series relays or as a field-installable upgrade kit for retrofitting. It comes standard with the SEL-849 Motor Management Relay and is an option when ordering the SEL-851 Feeder Protection Relay.

What is the maximum number of arc-flash sensors I can connect to an SEL relay?

Depending on the model, SEL relays can support up to 8 sensors. The SEL-710-5, SEL-751, SEL-787L, and SEL-787Z support an optional 8-sensor card. The SEL-751A and SEL-851 support a 4-sensor card. The SEL-849 has a single integrated arc-flash sensor.

## Light Sensors

Why do I need light sensors? Isn't the overcurrent element in a protective relay sufficient to sense when an arc-flash event occurs?

The light sensor protects against a false trip for an external fault. A protective relay with overcurrent would indeed sense the current surge from an arc-flash event, but it wouldn't know whether it was an internal fault or an external fault on the feeder or the protected equipment downstream. SEL arc-flash detection can differentiate between an external fault and an internal fault inside the switchgear by sensing the light flash via light sensors. SEL AFD-equipped protective relays detect an arc-flash event by detecting the simultaneous occurrence of both the fault current and the arc-flash light, triggering an immediate trip within the first quarter cycle of the arc-flash event.

## How does the SEL light-sensing technology work?

The SEL arc-flash technology uses two types of light sensors: point sensors and bare-fiber sensors. Point sensors intercept some of the light created by the arc flash at a single location, such as inside a breaker compartment. The light is brought to the relay via one of the fiber-optic cables connected to the point sensor. Bare-fiber sensors detect arc-flash light over the entire length of a fiber loop and are ideal for large areas, like bus compartments.

## How do I know that the arc-flash-sensing technology will continue to work over time? Do I test the sensors periodically to verify that they're working?

The SEL arc-flash point and bare-fiber sensors are equipped with two fiber-optic cables. One is used to channel light from an arc-flash event. The other fiber emits a specific light pattern every 10 minutes in a loopback test. A red LED light will blink, signaling that this test is occurring. If the test is unsuccessful, the relay will alarm, indicating that there is something wrong with one of the sensors. You can also initiate the test manually. (Note: an alarm does not disable the scheme. If a fault occurs in the gear during an alarm condition, the sensor continues to send light to the relay.)

## How do I test the arc-flash sensors during commissioning to verify that they're in working order?

Once the arc-flash equipment is installed, it requires an onsite commissioning test to verify that the entire protection system works as designed. Your engineers can perform the testing, or you can contract with SEL Engineering Services to do the testing. We can also provide oversight services while your engineers carry out the tests.

There are two methods to test SEL arc-flash detection systems:

1. Use the optional SEL-4520 Arc-Flash Test Module in conjunction with a current source. It generates a light flash at the same time it applies current to the relay, thereby testing the simultaneous application of light and current, and looks for the relay to produce a trip, thus verifying that detection functions (light + overcurrent) are operating correctly.
2. Use a professional-grade camera flash and a primary current source (Omicron, Doble, etc.). The camera flash, supervised by an overcurrent from the relay test set, will exercise the 50PAF and TOLx elements in the relay.

## When should I use the bare-fiber sensor vs. the point sensor? Can I mix and match them on the same relay?

You would typically use the bare-fiber sensor to protect bus runs when you have a large area to cover. You can also install it in circuit breaker compartments, metering compartments, and termination compartments—as long as you have 0.5 meter of exposed fiber in every compartment. Point sensors are generally easier to install in retrofit applications where you have space constraints and can't get fiber from one compartment to the other. You would normally use bare fiber in new construction where you can access the compartments before the equipment is installed. You can use any combination of bare-fiber and point sensors with SEL protective relays that support AFD. For additional details on sensor selection and placement guidelines, please refer to the SEL application guide "Using SEL Relays for Arc-Flash Detection," available at [selinc.com](http://selinc.com).

## **Has there ever been an arc-flash event where the arc-flash sensors were destroyed before they signaled the relay?**

No. SEL engineers tested the SEL-751A and specifically placed the arc-flash sensor in the middle of the arc-flash event to ensure the sensor was exposed to the full effects of the plasma. The sensor correctly sensed the event and sent a message to the relay within the first quarter cycle of the event. The sensor was eventually destroyed (in 2.5 cycles), but not before correctly detecting the arc flash. This testing is documented in the SEL technical paper “High-Current Qualification Testing of an Arc-Flash Detection System,” available at [selinc.com](http://selinc.com). SEL recommends replacing the sensors after they have been exposed to an arc-flash event.

## **Does SEL sell or provide the necessary tools to cut and install arc-flash fiber-optic cabling?**

Yes. SEL supplies preterminated fiber to your specified lengths. SEL also offers field-termination kits for V-pin and ST® fiber-optic splices and terminations. For specific part numbers, see the SEL application guide “Using SEL Relays for Arc-Flash Detection,” available at [selinc.com](http://selinc.com).

# **Installation**

## **Where do you recommend placing the arc-flash sensors in the switchgear?**

Place the sensors somewhere in the switchgear where an arc-flash might occur and where they are not overly obscured by other equipment. When an arc flash occurs, it is not a point source of light, but the plasma created by the event is a very large and extremely bright light source (>1,000,000 lux) that will fill up the entire area. For additional details on sensor selection and placement guidelines, please refer to the SEL application guide “Using SEL Relays for Arc-Flash Detection,” available at [selinc.com](http://selinc.com).

## **Are SEL light sensors vulnerable to dust?**

Not typically. At their default pickup setting of 3 percent, the sensor only needs 80,000 lux, and the arc-flash intensity is 1,000,000–12,000,000 lux. Therefore, dust should not adversely affect the light sensor’s ability to detect an arc-flash event.

## **How does SEL recommend adjusting the sensitivity of the sensors?**

We recommend leaving the point sensors at their default pickup level of 3 percent unless you have a specific reason for changing them. The only reason you would typically modify the settings (to, say, a pickup threshold of 10 or 20 percent) would be if you had a problem with too much ambient light. The relay will tell you if you have too much ambient light as part of the diagnostic check. If the relay sees light over the pickup threshold for more than 10 seconds, it will set an alarm bit for ambient light. Too much light is unusual, however, since the interior of the switchgear is not typically exposed to direct sunlight.



# Technology

## **If the relay sees the fault current, why does it need the light sensor to trip faster?**

When the relay sees the fault current, it does not know if it is an arc-flash event, an external fault, or even a nonfault condition (e.g., transformer inrush or motor start inrush). The presence of the arc-flash light verifies that an arc flash is occurring and prevents a false trip.

## **Does the overcurrent supervision that SEL uses slow down the AFD speed?**

No, it doesn't. Current is the input to the arc flash, so you need to have current first, and the light actually lags behind the arc-flash current. When we performed arc-flash tests, we observed the current leading the light by 1.5 ms.

## **If the switchgear is exposed to a light source, such as a camera flash, would that trigger the SEL protective relay to trip?**

No. The overcurrent condition would not be satisfied, and the relay would be prevented from tripping.

## **What if only an overcurrent condition were to occur?**

When an overcurrent condition (e.g., a transformer inrush or a motor-starting load) exists, if that current level is higher than the arc-flash pickup level, the SEL arc-flash protective relay will not trip because both conditions (light + high current) are not present.

# Arc Flashes in Motor Control Centers (MCCs)

## **Is AFD needed for low-voltage MCCs?**

Arc-flash events do occur in low-voltage motor control circuits. Neither the contactor nor the molded-case circuit breaker are able to interrupt an arcing fault that occurs inside the MCC bucket. The fault must be interrupted by an upstream device with a breaker on the incomer to the motor bus. When an optical sensor inside the MCC bucket is connected to an SEL-710-5, SEL-751, SEL-751A, SEL-787L, or SEL-787Z, the relay will issue a trip in a quarter cycle (4 milliseconds typical relay operate time) or as fast as 2 milliseconds after detecting both light and overcurrent. With an SEL-851, the relay will issue a trip as fast as 1 millisecond after detecting both light and overcurrent. With an SEL-849 inside the MCC bucket, the relay will detect light from the arcing fault and send an IEC 61850 GOOSE message to an upstream relay in three-quarters of a cycle (7 to 14 milliseconds typical relay operate time).

NOTE: The relay operate time does NOT include the breaker operation time. A three-cycle breaker adds as much as 50 milliseconds to the total trip time. Shunt trips for low-voltage breakers typically have a clearing time of less than three cycles.

## What communications were used in SEL arc-flash testing for an MCC?

Our arc-flash MCC testing configuration consisted of an SEL-849 communicating via IEC 61850 GOOSE messaging to an SEL-751 upstream on the main breaker. High-speed, reliable IEC 61850 GOOSE messaging is frequently used for communications-assisted tripping applications. For additional details, please refer to the SEL application guide “MCC Arc-Flash Protection Using the SEL-849 Motor Management Relay Via IEC 61850,” available at [selinc.com](http://selinc.com).

## How is the arc flash mitigated inside of an MCC bucket?

Using hardwired connections or communications, the SEL-849 sends a signal to the SEL-751 or SEL-751A on the incoming feeder, acknowledging that an arc-flash light source has been detected in the MCC bucket. The SEL-751 or SEL-751A will see the fault current going into the motor bus, and it will make the trip decision, clearing the bus and thereby removing the arc-flash hazard from the MCC. For more information, refer to the SEL application guide “MCC Arc-Flash Protection Using the SEL-849 Motor Management Relay Via IEC 61850,” available at [selinc.com](http://selinc.com).

# Other Mitigation Technologies

## What other types of arc-flash mitigation are available in addition to SEL’s combination of light-sensing detection and overcurrent supervision?

Other arc-flash mitigation strategies include the following:

1. Light-Sensing Only—We do not recommend this approach, as it is vulnerable to unexpected light sources (flash photography, lasers, etc.).
2. Light Flash, Supervised by Pressure—We do not recommend this approach, as sound pressure is very challenging to test during commissioning.

## Is maintenance switching sufficient to mitigate against arc flashes, or is more required?

A lot of SEL customers use a maintenance switch (a button on the front of the relay) that, for instance, changes the settings group from inverse time overcurrent protection to instantaneous trip mode. This takes 1.5 cycles to trip, but with arc-flash detection, the relay can respond in 0.25 cycles. One of the disadvantages of the maintenance mode is that it is process-dependent; it only works if someone turns it on. It can also miscoordinate and trip the bus for feeder faults if workers forget to disable it when they have completed work.

## If we have arc-resistant switchgear in place, is arc-flash mitigation via protective relays really necessary?

Arc-flash-resistant switchgear can be a good backup solution to arc-flash mitigation technology, but we recommend avoiding it as the primary protection. Unlike arc-flash mitigation technology, arc-resistant gear does not actually reduce the incident energy produced by an arc-flash event. The gear is designed to redirect the blast away from personnel and therefore requires sufficient vertical clearance to redirect the gases out of the roof. The presence of such venting is also a consideration during plant maintenance (e.g., roofing and HVAC systems). Arc-resistant switchgear will only perform as designed if the doors are closed when the arc occurs, which may not be the case. SEL arc-flash mitigation works regardless of the door position and effectively reduces the incident energy of the arc-flash, resulting in a smaller blast. A smaller blast results in reduced damage to equipment and, most importantly, increases safety for personnel.

# Personal Protective Equipment (PPE)

## Should a worker rely on AFD when selecting PPE, or is it for equipment protection only?

Arc-flash mitigation using protective relays helps protect both personnel and equipment. The relay operation time is always used in the calculation to reduce potential incident energy levels. The light plus overcurrent technology in SEL protective relays allows the relay to trip faster, which reduces potential incident energy levels. Some customers have determined that a reduction in PPE was warranted due to substantial reductions in arc-flash-generated potential incident energy. However, reductions in PPE selection should only be done after a detailed arc-flash and short-circuit study is performed by a qualified electrical engineer following federal and state guidelines.

## How can SEL show it is safe to reduce the PPE category?

SEL Engineering Services can perform an arc-flash study and provide an arc-flash hazard warning plan, which includes customized arc-flash and shock hazard labels. If you previously performed an arc-flash study and already have safety stickers in place, but have since changed the equipment configuration (including protection), then a new arc-flash study is required. SEL engineering studies can provide these services.

## Resources

### Where can I get more information?

To learn more, you can refer to the following resources on [selinc.com](http://selinc.com).

#### Application Guide

“Using SEL Relays for Arc-Flash Detection”

#### Application Notes

“Applying Arc-Flash Detection With Air-Magnetic Circuit Breakers”

“MCC Arc-Flash Protection Using the SEL-849 Motor Management Relay Via IEC 61850”

#### Technical Papers

“Challenges and Solutions of Protecting Variable Speed Drive Motors”

“Add Trip Security to Arc-Flash Detection for Safety and Reliability”

“High-Current Qualification Testing of an Arc-Flash Detection System”

“Arc-Flash Protection for Low- and Medium-Voltage Panels”

“Verify Performance and Safety of Arc-Flash Detection Systems”

**SEL SCHWEITZER ENGINEERING LABORATORIES**

Making Electric Power Safer, More Reliable, and More Economical  
+1.509.332.1890 | info@selinc.com | selinc.com

© 2025 by Schweitzer Engineering Laboratories, Inc.  
LM00355-01 • 20250414

