

Testing Considerations for Line Current Differential Schemes

Keith Lee

Hydro One Networks Inc.

Dale Finney, Normann Fischer, and Bogdan Kasztenny

Schweitzer Engineering Laboratories, Inc.

© 2012 IEEE. Personal use of this material is permitted. Permission from IEEE must be obtained for all other uses, in any current or future media, including reprinting/republishing this material for advertising or promotional purposes, creating new collective works, for resale or redistribution to servers or lists, or reuse of any copyrighted component of this work in other works.

This paper was presented at the 65th Annual Conference for Protective Relay Engineers and can be accessed at: <http://dx.doi.org/10.1109/CPRE.2012.6201247>.

For the complete history of this paper, refer to the next page.

Published in
*Line Current Differential Protection: A Collection of
Technical Papers Representing Modern Solutions, 2014*

Previously presented at the
PAC World Africa Conference, July 2013,
48th Annual Minnesota Power Systems Conference, November 2012,
and 65th Annual Conference for Protective Relay Engineers, April 2012

Originally presented at the
38th Annual Western Protective Relay Conference, October 2011

Testing Considerations for Line Current Differential Schemes

Keith Lee, *Hydro One Networks Inc.*

Dale Finney, Normann Fischer, and Bogdan Kasztenny, *Schweitzer Engineering Laboratories, Inc.*

Abstract—Testing line current differential (87L) schemes is more complicated than testing directional comparison schemes. The latter exchange simple on/off (permission or block) signals that can be conveniently checked at the output of a given relay and conveniently forced at the input to a given relay in the scheme. Line current differential schemes exchange synchronized current values that cannot be easily intercepted or forced at the 87L communications port of the relay. Moreover, the communications channel is an integral part of the 87L scheme, and its characteristic can impact some fundamental aspects of the scheme, such as sensitivity and speed. Therefore, it is preferable that the actual channel be in use when testing the scheme. Line current differential schemes that apply external time sources for synchronization need to be tested with time sources as well. Often, 87L schemes are tested with multiple crews dispatched to two or more line terminals using either test sets synchronized via the Global Positioning System or other methods of controlling the relationship and timing between current sources at the line terminals.

This paper presents several approaches to testing 87L schemes. These approaches include verification of relay hardware, firmware and settings, channel performance, and, if used, external time sources. The paper also describes features of line current differential relays and multiplexers to aid testing.

I. INTRODUCTION

This paper is concerned with field testing of line current differential (87L) schemes, including commissioning, routine maintenance, and troubleshooting. The paper explains some unique aspects of 87L schemes in the context of field testing, reviews typical approaches to testing, presents a case study of one particular approach to testing 87L schemes, and finally catalogs common test features built into 87L relays.

Before discussing field testing, we first look at the topic of relay testing in general in order to make some important distinctions and to gain a better understanding of the many different tests performed during the various stages of product design, manufacturing, approval, installation, and operation. Realizing the purpose and scope of the many tests allows for the creation of more comprehensive and efficient test plans for the field tests.

When a protection scheme is finally placed into service to protect primary plant apparatus, that scheme and, specifically, the protective devices in the scheme have been subjected to a barrage of tests to verify that the scheme can protect the primary plant under any adverse system or environmental

conditions. In general terms, the tests can be divided up into three categories:

- Design and manufacturing tests
- Product certification tests
- Field tests (commissioning, routine maintenance, and troubleshooting)

In Appendix A, we briefly review these three test categories, each having its own purpose and scope. Appendix A is beneficial to readers who are not involved in relay selection and certification. Understanding the purpose and scope of the tests performed prior to the field tests is important because it allows for adjusting test plans for efficiency in terms of both time and effort, as well as minimizing the number of installation deficiencies left uncovered.

In Appendix B, we describe in more detail the typical approaches to field testing of protection schemes, focusing specifically on initial commissioning, routine maintenance testing, and troubleshooting. Appendix B is beneficial to readers who are not involved in these types of relay testing.

With the overall background on relay testing provided in Appendix A and Appendix B, this paper focuses specifically on field testing of 87L schemes.

Sections II and III explain challenges unique to the testing of 87L schemes. We then examine typical approaches and methodologies used to test these schemes (Section IV). Lastly, we present a case study, lessons learned, and review of test tools that are available in 87L relays (Sections V and VI).

II. CHALLENGES IN FIELD TESTING OF 87L SCHEMES

87L schemes pose some unique challenges during field testing when compared with other types of line protection. These challenges, even though different for analog and microprocessor-based 87L schemes, stem from the same fact: namely, that an 87L scheme protecting a power line is comprised of multiple 87L relays located at different substations and sharing information via a communications channel (or channels).

A. Testing 87L Schemes Versus Communications-Assisted Schemes

Communications-assisted schemes (permissive overreaching transfer trip [POTT], permissive underreaching transfer trip [PUTT], directional comparison blocking [DCB], and directional comparison unblocking [DCUB]) are

comprised of multiple relays linked via communications channels. This is similar to 87L schemes. However, there are crucial differences between communications-assisted and 87L schemes.

In a communications-assisted scheme, the protection functions of the local relay are not dependent on any analog quantities from the remote relay(s) that bound the protected zone, but only on a simple on/off trip permission or block. As such, the received signals in the scheme do not need to be aligned with any local signals. This means that as soon as remote data arrive at the local relay, the data can be directly consumed.

For an 87L element to accurately reflect what is happening on the power system, it has to use signals that are measured at the same instant in time from all terminals bounding the protected zone. Because data transmission does not occur instantaneously and data from different terminals arrive at different times, both the local and remote data must be stored or buffered in microprocessor-based 87L relays. Once all the data from the same instant in time are available in the relay, the relay selects all the data from the same instant in time (aligns) and passes the data to the 87L function for processing. Any error in aligning the data from the different terminals results in fictitious operating current.

87L relays invariably use one of two methods to align remote data with local data. In channel-based data alignment (also known as the ping-pong method), Relay 1 attaches a time stamp to the transmitted data. Relay 2 transfers the received time stamp with its next outgoing packet. Relay 1 can then determine round-trip channel delay by comparing this time stamp to its present local time. The delay in each direction is assumed to be one-half of the round-trip delay, which is correct only if the channel is symmetrical.

External time-based data alignment makes use of an absolute time reference, such as a Global Positioning System (GPS) clock, to ensure that relay clocks are synchronized. Relay 1 attaches a time stamp to the transmitted data. Relay 2 compares this time stamp to its clock to determine the latency. This allows delays to be determined in both directions.

Some relay models may only support the ping-pong method. Others support both and may include a mechanism to fall back to channel-based data alignment if the external time source fails. If channel delays are not expected to be significantly asymmetrical, then channel-based data alignment may be preferable because it is not subject to time source failure.

When we compare 87L schemes with communications-assisted schemes, we see that although channel characteristics, such as latency, do play a role in the performance of communications-assisted schemes, the relays and communications equipment that make up these schemes can be tested as individual entities autonomously from one another because of the following:

- The protection elements (such as the forward-looking distance elements, reverse-looking distance elements, and directional elements) respond exclusively to local currents and voltages.

- The carrier signals can easily be simulated locally by forcing relay inputs and outputs.
- The communications channel is relatively easy to test because its sole function is to deliver a simple permission or block signal.

Of course, before placing the scheme in service, it is a good engineering practice to verify the overall performance of the scheme by exercising both the protective relay and the communications equipment to ensure that they operate correctly as a system.

By contrast, 87L schemes do not allow the following of this approach. Instead, the following aspects need to be considered.

B. 87L Scheme Testing Versus Relay Testing

The 87L protection element requires time-aligned currents from the local and remote terminals. Naturally, the scheme will need to be injected at all the different terminals simultaneously in order to test it. This means not only that currents must be applied at multiple terminals but the injected currents must be applied with controlled phase and timing with respect to one another.

One reason for testing the complete scheme is to verify the restraint action of the 87L element. To verify the restraint mechanism (such as percentage slope or Alpha Plane [1]) requires injecting currents that emulate both internal and external fault conditions. In other words, we want full control over the magnitude and angle of the local and remote currents as part of the test. Without that control, we cannot verify the operating characteristic, only the value of the pickup setting. Testing the complete scheme also evaluates the overall system performance, including communications performance.

In the case of a dual-breaker application with dual current transformer (CT) input relays, presuming that the algorithm generates restraint for individual CT inputs, we can test the restraint action by simulating a close-in external fault with current flowing in and out of the zone at the local terminal with no feed from the remote line terminal(s). This, however, does not fully verify the restraint action from remote currents, and the approach only applies to dual-breaker line terminations using dual CT input relays.

Can the remote currents be injected locally via the 87L communications port using specialized test equipment? The answer is no. Modern 87L relays work with proprietary data packets, making it very difficult to intercept or force the 87L packets at the 87L communications ports. The hypothetical approach of probing the 87L port for data in order to support local testing would not work for a number of reasons, not only the unavailability of proper testing tools or the messages being proprietary. Even more importantly, a typical 87L relay expects an identical (compatible) 87L relay communicating with it over the 87L port. The data exchange has more dimensions to it than just sending values of the currents. As a part of a typical time synchronization and current alignment algorithm, each relay is expected to send and receive packets in a certain way, and included in the packet payload are time stamps of both local current data transmitted, as well as time

stamps of packet transmitting and receiving events [2]. In addition, relays of a typical 87L scheme can, and often do, exchange extra data aimed at improving their overall performance. This can include an external fault detection bit, blocking bit, time-quality bit, and so on.

For these reasons, testing the overall 87L scheme, and not the individual 87L relays, is desired. We can postulate possible ways of testing the scheme, including the following:

1. True multisite testing with actual relays installed in their actual environment and using the actual channel (or channels). This approach most closely simulates an actual power system fault.
2. Using a spare relay (or relays) connected back to back to substitute for the remote relays and the actual communications channel. A variant of this approach could use the actual channel looped back at the remote terminal and connected to the spare local relay.
3. Performing a loopback test (i.e., allowing the local relay to communicate with itself).
4. Providing test features as a part of the relay functionality so that a certain amount of substitution is performed within the relay itself, allowing some of the local currents to appear as remote currents.

Approaches 2 through 4 would require repeating the tests at each substation. Section IV elaborates more on these possible approaches to testing.

C. Importance of the Communications Channel

The communications channel is an integral part of any 87L scheme. Channel symmetry (equal delays in the receiving and transmitting directions), latency (channel delay), bit error rate (BER), jitter (instantaneous variability in the communications clock), and wander (slower swings in the communications clock) can affect performance of the 87L scheme. Consider the following [2]:

- Channel asymmetry is the result of different time delays between the channel transmit and receive paths. In the channel-based current data alignment mode, asymmetry in the channel affects how the currents are aligned [2] and is manifested as a phase shift between the local and remote currents, resulting in an increase or decrease in the apparent differential current [3]. This misalignment can cause severe security and dependability problems and, at a minimum, would affect the accuracy of the operating characteristic of the 87L element.
- Channel latency impacts the trip times of the 87L scheme. A timing test using the actual channel yields realistic results.
- Bit errors may prevent the 87L function from being available 100 percent of the time. Upon loss of a packet, different relays may exhibit short periods of unavailability varying from milliseconds to seconds, depending on the number of packets lost and the relay ride-through capabilities.

- Excessive jitter or drift in the relay or communications equipment clocks can cause lost packets, with potential impact on availability as described previously.

The communications channel is typically tested using common telecommunications methods and test equipment before it is handed over to the relaying department to be commissioned as part of the 87L scheme. Section III provides a short overview of some typical approaches to verifying digital protection channels.

Part of the relay commissioning procedure often requires the channel to be subjected to a substantial run time with the actual relay hardware communicating with one another in order to check the compatibility of the interfaces, identify issues (such as frame slips resulting in data loss), observe BERs as measured by the relay lost packet counters, and measure the unavailability time reported by the actual 87L devices.

Testing the 87L element with the actual communications network is more realistic and can potentially reveal issues related to the communications channel or equipment. One such scenario is the application of 87L with redundant channels (two relays communicating over two independent communications networks). The latency between the two channels is typically different, with the shorter path designated as the primary network and the longer path designated as secondary. Should one of the channels fail, the relay will communicate over the redundant channel, with various schemes of switchover provided by different manufacturers. Testing this switchover logic using the actual communications network can be beneficial in order to ensure that the protection can operate via this channel, if required, as well as to verify the channel switchover logic.

Another aspect of testing related to the communications channel is concerned with disturbance detection trip supervision and other security and signal consistency checks built into 87L relays. 87L data packets are secured using data integrity codes (such as Bose-Chaudhuri-Hocquenghem [BCH] or cyclic redundancy check [CRC]). Although the probability is extremely low, there is nonetheless always a danger that a bit error will go undetected, causing the receiving relay to accept corrupted data, act upon the corrupted data, and potentially misoperate. A common solution to this challenge is the use of disturbance detection supervision—extremely sensitive detectors responding to local currents and/or voltages and, as such, independent from the remote data and alignment algorithms—to supervise the output from the 87L elements [2]. Without local disturbance confirming the fault, the 87L operation is either delayed or inhibited by design.

Modern relays may include more supervisory conditions aimed at improving the security of the 87L scheme, given its distributed nature. For example, disturbance detection can also be performed on the remote data to verify that the trip condition is not spuriously created by an undetected hardware failure of the local relay [2].

For all these reasons, test procedures for 87L schemes should emulate expected power system phenomena as closely as possible, or else unexpected test results may be encountered.

D. Increased Chances of Human Errors

Because 87L schemes are distributed, they increase the risk of human errors. Just the need for proper isolation of all the relays in a given scheme, regardless of the testing method, and the sheer fact of having to deal with multiple relays at multiple sites using larger test crews can increase the number of errors. These errors are the typical test errors briefly described in Appendix A, such as failing to isolate or restore critical outputs (trip or breaker failure initiate), cross-connecting wrong 87L relays, and forgetting to isolate the remote relays when injecting currents into the local relay.

III. 87L CHANNEL VERIFICATION FROM THE COMMUNICATIONS PERSPECTIVE

Before a new 87L scheme is installed and commissioned, the protection engineering group of a utility specifies and requests a communications channel from the communications group. Prior to handing over the channel to the protection group, communications engineers test the channel and verify that it meets the stated requirements. These tests are typically performed using a generic approach without much focus on the type of application. However, the scope of these tests allows for creating better 87L commissioning procedures by taking advantage of what has been already checked and recognizing what needs to be verified independently and what needs to be left to continuous channel monitoring and alarming after the scheme is put in service.

From the channel testing perspective, there is a major difference between direct point-to-point 87L channels and multiplexed channels.

A. Testing Direct Point-to-Point Channels

These channels are passive channels comprised of direct fiber links between substations. Even if they include signal regeneration devices (amplifiers or repeaters) for long runs, these devices can be treated as “black boxes,” allowing a simple end-to-end test of the fiber medium.

Testing direct fiber links is relatively straightforward and is focused on verifying the physical part of the channel. The first step to confirm the integrity of a fiber link is an optical time-domain reflectometer (OTDR) test. This test involves sending pulses down the fiber and measuring the magnitude and delay of the reflections. Among other things, it gives the power loss for each splice, as well as the total loss. Sending test bits using standard communications test sets in the loopback fiber pair and verifying BERs complete the test in most cases.

Direct point-to-point channels not only perform very well but are also easy to test because they are passive, inherently symmetrical, and inherently of fixed (and typically low) latency and are not shared between multiple applications.

B. Testing Multiplexed Channels

Multiplexed channels for 87L applications commonly take the form of DS-0 channels [1] multiplexed over synchronous optical network/synchronous digital hierarchy (SONET/SDH) networks [4]. Unlike direct fiber links, these channels are digital (meaning the 87L relays and communications equipment modulate and sample digital bits when communicating), are not inherently symmetrical, are not inherently of low or fixed latency, can include a large number of interposing devices carrying the data, and exhibit a fair amount of variability due to automatic and manual network reconfiguration, as well as network growth. All these factors call for more comprehensive testing compared with direct fiber links.

Typically, the following channel characteristics are verified.

1) Communications Interface Compliance

These tests verify that the channel supports a compliant interface, such as EIA-422, G.703, or IEEE C37.94. The purpose of the test is to ensure that the 87L relay and communications equipment directly interfacing with the relay can communicate in the most basic sense of being able to understand each other’s data. These tests include basic communications checks (such as clock jitter and wander), clock recovery, signal levels for copper and power budgets for fiber connections, and so on. These tests are performed using standard communications test sets and are generic for a wide variety of utility applications.

These tests allow for saving considerable troubleshooting time should the network not comply within the requirements of a given interface (such as by having an excessive clock jitter).

Line current differential relays are end devices. Therefore, their compliance with the interface can be checked as part of type or certification testing and does not have to be reverified as part of relay commissioning (still, some run time of actual relays working over the actual network is beneficial prior to putting the scheme in service). On the network side, however, compliance may depend on network configuration and conditions, and therefore, it should be verified as part of channel commissioning.

2) Bit Error Rate

The BER test verifies the ability of the channel to cleanly deliver the data between the two network ports. Standard communications test sets are used to inject proper sequences of data into a loopback channel and read back the sent bits to detect errors in transit. This test is a catchall test because it can detect a wide variety of issues occurring anywhere between the two ports of the tested channel, including the following:

- Noise interfering with the channel medium.
- Noise interfering with the active network devices.
- Failing or marginal components in the active network devices.

- Marginal electrical signals or power budgets in fiber.
- Issues with communications clocks causing framing errors and otherwise leading to lost data.
- Channel interruptions due to network switching and other events.

Typically, the BER test is run over a period of 24 hours in order to expose the channel to cyclical network events, such as changing bandwidth usage patterns in utility business applications or periodic supervisory control and data acquisition (SCADA) activities, as well as random events, such as short circuits or switching in the high-voltage grid. If the SONET/SDH network includes microwave links, the BER test can be run over longer periods of time in order to expose the channel to weather-related variability. Also, note that for more accurate BER measurement, more bits need to be sent and verified, calling for longer tests at lower bit rates while allowing for shortening the test for higher bit rates.

3) Channel Latency

Multiplexed networks are normally associated with additional channel latency. The worst-case latency can be estimated by network design analysis but should be verified as well to discover any equipment configuration errors or failures.

Typically, a round-trip channel time is verified on a loopback channel using a standard communications test set over a period of time (such as the 24 hours typically used for the BER test). Half of the round-trip time is the channel latency, if the channel is symmetrical.

Testing for channel latency separately in the transmitting and receiving directions for asymmetrical channels is difficult. Typically, channel latency is verified by a combination of network analysis and a direct measurement of the round-trip delay.

4) Channel Symmetry and Asymmetry

Multiplexed channels are not inherently symmetrical, particularly in networks using telecommunications-class equipment [2]. 87L applications configured to use external time sources for current data alignment (GPS) are not adversely affected by channel asymmetry. However, 87L applications configured to use channel-based current data alignment (ping-pong method) are very sensitive to channel asymmetry [2].

Typically, SONET/SDH networks exhibit a natural asymmetry of a fraction of a millisecond due to unavoidable data buffering for multiplexing, demultiplexing, and natural clock wander. These asymmetry levels are acceptable. Asymmetry in the order of 1 to 2 milliseconds becomes problematic and can lead to relay misoperations [3].

Channel symmetry is typically enforced through the proper configuration of the network multiplexers (when switching paths upon the channel or equipment failures, the network needs to switch both directions, not just one) but is not verified by a direct measurement using standard communications tests.

Direct measurement of asymmetry in the field would require DS-0 test sets at both ends of the channel and access to

a common time reference (such as a GPS clock). Channel symmetry is not a typical requirement in the communications world, and therefore, available communications test sets do not support a common clock reference for DS-0 testing. Some communications test sets offer DS-0 propagation delay measurement capability by comparing when the traffic is transmitted to when it is received. We could measure the delay in one direction and then compare it with the delay in the opposite direction to check for asymmetry. However, this test can only be performed in a laboratory setting where the equipment is in close proximity. It is typically not a practical test for the field because equipment would be separated by greater distances.

As a result, channel symmetry—if requested for the 87L application—is carefully configured in the network. The network configuration parameters ensuring channel symmetry can be reverified as part of channel or 87L scheme commissioning.

C. Limitations of Channel Commissioning

Channel commissioning faces a number of limitations. It can identify obvious issues with the network, but it does not guarantee good performance over extended periods of time.

Some of the limitations, such as difficulty in measuring channel asymmetry, have been mentioned earlier. Extra issues to consider include the following:

- The alternate path (or paths) in the SONET/SDH network is difficult to verify. Normally, the network works as designed, with the primary path carrying the data. In order to exercise alternate paths, we would have to cause a channel failure (unplug the fiber connections) or equipment failure (power down a communications device). Such operations are substantial disruptions and are typically not permitted.
- The communications network is a “living organism” that changes constantly as a result of varying data traffic patterns; end devices added or removed; communications devices added, replaced, or upgraded; temporary configuration and repairs; equipment failures; and so on. From this perspective, SONET/SDH networks are much more robust than other types of networks, but still are exposed to some of the same issues. Running a channel test for 24 hours only constitutes a snapshot of the channel characteristic.
- The approach taken for utility communications networks somehow differs from typical protection approaches. For example, an upgrade or replacement of a network device (firmware or hardware) does not trigger a widespread recommissioning of services that depend on said device. Network configuration parameters are entered as a set of dispersed values because the industry does not follow the concept of rigorous settings files that can be easily loaded or restored upon replacing a device. Network transport engineers can reconfigure the backbone of the network with little coordination with the network circuit

engineers who may have a better appreciation of the applications served, such as the 87L schemes. This approach results from heavy reliance on standardized interfaces and the assumption that conformance with the interface standard and the average, not the worst-case, channel performance is sufficient. As a result, normal activities of the communications department to maintain and expand the network create constant changes that can alter the performance of any given channel, if proper procedures are not in place.

D. Continuous Communications Diagnostics and Monitoring

Being live organisms rather than static entities, utility communications networks rely heavily on continuous monitoring and diagnostics built into both the communications and the end devices.

Some of the newer protection-class SONET multiplexers provide a wide variety of monitoring functions, not only generic, such as T1 frame CRC failure rate, but also specific to critical utility applications, such as channel latency or channel asymmetry [2].

Most 87L relays provide independent monitoring at the DS-0 level, including lost packet counts, round-trip delay, channel asymmetry (if both relays of the channel are connected to the absolute time reference), step change in the round-trip delay, and so on (see Section VI, Subsection A for more details).

It is highly recommended to enable the continuous channel monitoring functions available in 87L relays and consider the associated alarms as critical alarms. This way, changes in the network that are likely to occur over the lifetime of a commissioned 87L scheme have a chance to be detected and rectified (if needed) before causing any serious problems, such as a relay misoperation, a failure to trip, or a delayed trip.

IV. GENERAL APPROACH TO FIELD TESTING OF 87L SCHEMES

The basic steps for field testing of a current differential protection scheme are summarized as follows.

Each of the communications channels of the scheme is configured and tested by the telecommunications personnel. The specifics of this testing phase are described in Section III.

The protection personnel can repeat some of the channel tests by applying 87L relays as the test sets and using their own criteria.

Subsequently, each relay is configured and connected to the communications network and its local external clock source for current data alignment (if used). The relays remain isolated from CT and voltage transformer (VT) secondary circuits and circuit breaker control circuits. At this point, the relay can be interrogated to determine if it is communicating with its remote relay(s).

If all relays are not communicating, then the configurations of the relays are compared with each other and with the configurations of the terminal equipment and/or multiplexers for consistency and correctness. Loopbacks can also be placed at various locations to determine the root cause of any communications problem.

When all communications are intact, then statistics or reports can be collected from the relay to confirm that packet loss and channel delays are within tolerances.

The differential element can then be injection tested. The mechanics for line current differential injection testing are described in [5] and [6]. In general, the goal is to check the points on the operating characteristic and the speed of operation. Injection values expected to produce trip or no trip outputs from the differential element are predetermined. These values are then simultaneously injected into the relays. Complications arise in the determination of test values in the case that CT ratios or nominal secondary currents are not the same at all terminals. Some method (GPS synchronization, for instance) is required to ensure coherent phase angles between the values at each relay during the test.

Once the differential element has passed all the required tests, the relays are connected to the CT and VT circuits. The differential elements can remain isolated from the circuit breaker trip circuits. With the line in service (protected by redundant or backup protection functions), on-load readings can be carried out. Using the relay built-in metering functions, the differential and restraint quantities are monitored and checked for correctness. Phase rotation and end-to-end phasing are critical checks to be made at this stage.

Once it has been confirmed that the relays are operating correctly with proper settings as evidenced by the on-load readings, a trip test can be carried out. The trip test is a final confirmation that the protection scheme will operate for a fault and trip all of the breakers making up the zone.

The following section elaborates on details in this overall approach, sharing the operating experience of a major utility.

V. OPERATING EXPERIENCE WITH TESTING 87L PROTECTION

This section shares some experiences of Hydro One Networks Inc. (HONI) regarding field testing of 87L schemes. HONI uses 87L schemes from different manufacturers, typically over a multiplexed SONET network. The test procedures are the same for all relay models.

A. Overview of 87L Application With SONET Multiplexers

HONI applies 87L schemes over multiplexed channels using the IEEE C37.94 standard for interfacing 87L relays with multiplexers at Nx64 kbps. Depending on the available telecommunications facilities at the substation, the Nx64 kbps channel can then be multiplexed using a T1 multiplexer [3] and further up the level with a SONET multiplexer.

HONI application philosophy is to not rely on external time sources for 87L data alignment (GPS). Instead, the 87L relays are configured to use channel-based synchronization (ping-pong method), and channel symmetry becomes a key consideration in 87L applications [2] [3].

Data sampling clock synchronization is required for each of the 87L communications channels and ports. If the 87L relay is connected via direct fiber, the 87L relay can be set to generate its own internal data sampling clock. More often, the 87L is connected to multiplexers that follow an external data sampling clock provided by the communications equipment.

It is important to ensure that data sampling clock synchronization is maintained or reestablished after an intermittent failure has occurred at any level of the communications channel. Some communications devices can buffer data when reacquiring the clock (reframing). This is done in an attempt to prevent loss of data. The consequence, however, is that as the buffer is filled, the data become delayed, resulting in asymmetry of the channel path. It has been the HONI experience that, in some cases, if the communications interface at the multiplexer or at the relay is not designed correctly, the communications channel itself may enter a lockup mode, resulting in permanent failure of the channel.

B. Testing Objectives

It is general practice at HONI to commission and maintain 87L schemes as complete systems, including the communications channel itself. This means that commissioning and maintenance of the 87L scheme must be performed simultaneously at all line terminals. Scheduling tests at all terminals requires extra effort because testing staff must be coordinated at different locations. Despite the need to schedule staff at all line terminals, the result is far superior from an overall system testing point of view, especially considering the great impact communications performance has on the overall end-to-end differential scheme.

Specific reasons for the multiterminal testing approach at HONI are as follows:

- The need to verify the complete scheme with all its nuances and interdependencies. Local testing of the 87L relay does not verify that the complete 87L system is functioning correctly. The integrity of the communication and the effect of the communications channel (channel delay, BER, 87L current data alignment, and so on) on remote currents are not fully verified using a single-end test.
- The need for the protection to provide full coverage. Depending on the power system topology and the logic implementation in the relay, the remaining relays not taken out of service for testing may not be able to provide full protection coverage. For example, for a three-terminal application (with tapped loads), the 87L (with Zone 2 distance supervision) may not provide the necessary reach because the Zone 2 elements may not be able to coordinate properly.
- The need to reduce the risk of inadvertent operation. When a differential relay at one terminal is taken out of service with communications still available to the remote terminals, failure to properly isolate the remote relay(s) can lead to misoperations because the differential current or trip bits can inadvertently be triggered.

C. Commissioning Test Methodologies

When performing 87L commissioning testing, it is important to have a clear demarcation between testing of the communications portion versus the relay portion and a clear purpose and scope for each case.

1) Communications

Prior to the installation of the 87L relay, preparation work is required to design, procure, and commission the communications channel down to the DS-0 level. The first level of communications testing can be performed at the DS-1 (T1) level provided from the SONET equipment using a DS-1 communications analyzer. At this stage, the channel is tested for jitter, BER, signal level, and so on for a period greater than 24 hours for a higher level of confidence. A typical T1 test set can perform checks on T1 or fractional T1 by transmitting various types of random data on the channel with the remote end looped back. Analysis of the received data can then be used to determine the health of the channel. The communications analyzer for the DS-1 circuit in a communications network is a mature piece of test equipment, with numerous test capabilities available. Once the DS-1 circuits are verified, a second level of testing at the DS-0 level can be performed.

End-to-end test equipment is used to evaluate the integrity of the DS-0 circuit. Often, there will be issues with the mapping of the DS-0 time slot, data sampling clock synchronization, inverted data bit, or bit errors. These issues need to be resolved prior to the approval (the handoff between the communications and protection departments) of the DS-0 circuit.

One type of test is a BER test. This test can only be carried out with the channel out of service. The test is performed using either two test sets connected at the ends of the channel or a single test set and a loopback placed at the far end. In this test, a pseudorandom sequence of bits is generated and transmitted over the channel. At the receiving end, the sequence is decoded and the numbers of errors are tabulated. The BER test must be carried out for an extended period of time in order to measure BER to an acceptable accuracy level. The BER test gives an indication of the level of impairment that exists on the test. This can then be checked against the relay manufacturer requirements.

Currently, when commissioning a DS-0 channel for an 87L application, HONI exercises the DS-0 circuit end to end for a period of time with a test set that uses the same communications channel interface as the 87L equipment. In fact, the test set can be the 87L relay itself, programmed specifically to monitor channel availability. This way, it provides a higher degree of confidence regarding proper operation of the channel with the actual end device. Another benefit of using 87L relays to verify the channel is the ability to test interfaces, such as IEEE C37.94, that may not be available in a commercial communications test set. The test setup with 87L relays exercising the channel is configured to generate commands simultaneously at both ends, with the remote end monitoring the commands received. At the end of the tests, general statistics, such as packets lost or the number of transmitted and received commands, can be gathered and inspected.

It is important to confirm that synchronization between the communications equipment and relay is maintained and the channel is working with minimal or, ideally, no issues, such as

packets lost or bit errors (Section III). A clock signal resides in the multiplexer or the 87L relay and is used to instruct the relays and associated terminal equipment (such as T1 multiplexers) as to when to transmit and when to receive each bit. Transmission and reception can occur on the rising or falling edge of the clock. Depending on the interface, the clock signal can be exchanged on a separate pair of wires or the clock can be embedded into the data stream [2]. When relays are connected over a direct point-to-point channel, one of the relays is configured to be the clock source (relay clock setting is internal) and the other relay receives the clock (relay clock setting is external). If the relays are connected through multiplexers, then the multiplexer typically provides the clock (both relay clock settings configured as external). Relays need to be configured properly (e.g., internal/external and rising/falling) with the communications network to define which device in the network is providing the data sampling clock timing. Failing to do so will cause the relay to lose packets intermittently or, if not, to fail completely.

Many 87L relays support channel monitoring to determine if the communications channels are in good condition, including data loss due to interface compliance and configuration issues. Relays also have features to perform a local loopback or remote loopback test on the communications channel. Using the relay internal channel loopback tests is important because it helps to determine if the channel meets requirements and works with the specific relay.

2) Relays

The 87L testing methodology is intended to check the functionality of the 87L elements with the goal to limit the time required for testing. It must be kept in mind that the purpose is to ensure the relay operates as per the intended settings files, based on fault studies, protection coordination, and so on.

The relay itself has been type and functional tested by the relay manufacturer and certified by the utility. Certification by the utility is a crucial step because it verifies that the given 87L relay model can interface and operate with the specific communications equipment of the utility.

In general, the 87L testing can be separated into two parts. The first part is to perform testing independently at all terminals to verify relay health, relay logic, and all other non-87L related elements. Typical testing of the relay includes exercising the contact inputs and contact outputs, verifying the tolerance of the digital signal processing module, verifying settings and logic, and so on, as explained in Appendix B. Channel failure alarms and relay failure alarms are also verified.

The second part is to exercise the 87L algorithm using the actual communications channel with current injection at multiple terminals. This must be performed with testing staff at each terminal working as a team.

The testing of the 87L element, although synchronized in nature, is performed at HONI without the use of GPS-

synchronized test sets. This test is described in detail later in this section. Testing staff are, therefore, able to use existing nonsynchronized test sets, which reduces the costs for having to purchase and maintain dedicated synchronized test sets for the 87L relays. This is made possible by careful manipulation of the injected currents at each terminal.

System testing requires the relay to be connected to the actual communications channel with current injection at multiple terminals. For this test, the concept of a local and remote terminal is introduced in the HONI 87L test procedures. At the local terminal, the injected current is switched from a predefault value to a fault value. At the remote terminal, the injected current is fixed. Injections are required at two terminals at a time to exercise the 87L algorithm with local and remote currents.

When testing a two-terminal application, each terminal acts as the local terminal under test with the other acting as the remote terminal (see Table I).

TABLE I
TWO-TERMINAL TEST SEQUENCES

Test Sequence	Type of Current Injection	
	Terminal 1	Terminal 2
Test 1	Local	Remote
Test 2	Remote	Local

For a three-terminal application, testing is done in pairs, with these terminals acting alternately as a local terminal and remote terminal (see Table II). This results in three test sequences for three-terminal applications.

TABLE II
THREE-TERMINAL TEST SEQUENCES

Test Sequence	Type of Current Injection		
	Terminal 1	Terminal 2	Terminal 3
Test 1	Local	Remote	None
Test 2	None	Local	Remote
Test 3	Remote	None	Local

The purpose is to allow each terminal to act as a local terminal and a remote terminal.

More specifically, the method works as follows. Current injection is applied at the remote terminal to simulate the remote current with no intent to dynamically change this current or align it with the local current to simulate internal or external faults. Subsequently, the local current is injected, and the local test crew determines the phase offset between the local and remote currents (the remote current is known to the local test crew based on the local 87L relay metering). This angle remains constant for the duration of the test because the remote and local test sets are synchronized to the ac voltage and therefore mutually synchronized, owing to the synchronism of the power grid. A block diagram of the test setup is shown in Fig. 1.

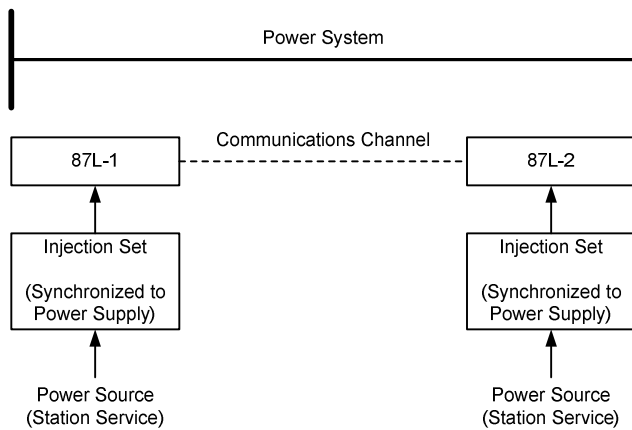

Fig. 1. HONI injection test setup

With this method, it does not matter which phase the test set is plugged into or the phase shift between the line terminals due to system power flow. It may be necessary to recalibrate the phase offset if we suspect that the test sets are out of synchronism or if the test lasts too long.

Subsequently, the determined angle offset is used by the local test crew to adjust the angle of local current to test the operating characteristic and the trip times.

First, the restraint and operating regions (5 percent below and above the trip point) of the operating characteristic are tested.

Second, a high differential current test is performed to measure the operating time of the 87L element.

3) System

After the verification described previously and after the on-load readings are taken and inspected, the 87L scheme is put into service. Testing of the complete protection zone is performed next. With outages arranged, the protection staff is able to perform test tripping of the zone and monitor the correct operations of the outputs, alarms, and other indicators to ensure the protection operates correctly.

Test tripping results in physical operation of breakers and associated switchgear to ensure the protection is capable of actually isolating the protected plant. Currently, the HONI practice is to initiate a trip test by a logical bit in the microprocessor-based relay. This approach is seen as less likely to result in a testing error because it is less intrusive than operating the relay via destabilization of the differential element (no need to open test switches, apply an injection test set, and so on). Ideally, manipulation of this logical bit should be performed without a settings change.

The test trip is usually performed once all of the protective relays making up the zone have been tested. Trip testing requires close involvement of system operators because an in-service line is tripped during this test. The operators must ensure that the power grid will remain intact in the event of another real contingency during a trip test of the line. For a line trip test, the line is typically tripped with automatic reclosing initiated shortly after to restore the system to its original state.

D. Routine Maintenance Test Methodologies

1) Communications

The communications devices at the SONET level and the T1 multiplexer level incorporate a fair amount of self-monitoring (see Section III, Subsection D) with real-time network monitoring and alarms available at the operating center. As a result, only limited maintenance is required, including a visual inspection, power supply check, settings comparison, BER check at the T1, and alarm check with the operators.

At the DS-0 channel level, the 87L relay plays an important role in monitoring the communications characteristics. The 87L relays can provide values, such as packets lost and data integrity errors (BCH, CRC). Any channel failure alarm or channel asymmetry alarms are routinely checked.

2) Relays

Presently, the methodology applied for routine relay maintenance is a subset of the commissioning test because the commissioning procedure has already been designed to reduce the amount of time required for testing. The 87L relays need to be taken out of service at all terminals. Some of the testing, including checks for the simple pickup and dropout of the elements, is not needed. A comparison of settings files ensures that nothing in the configuration of the relay has changed since the last maintenance. As an extra benefit, relay logic does not need to be reverified because a settings comparison has been performed.

87L relays used by HONI include self-monitoring functions; thus focus can be placed on those parts of the relay that are not self-monitored. For instance, the self-diagnostics will typically detect failure over a large portion of the I/O circuitry or the analog circuitry, but some of the terminating components cannot be covered (for instance, output contacts or interposing CTs inside the relays).

Maintenance includes visual inspection, power supply check, settings comparison, exercising the contact inputs and contact outputs, verifying the tolerance of the analog relay circuitry, and so on. Some of the tests can be carried out through a comparison of on-load readings with those of a known good relay (backup protection, for instance).

Timing tests of the protection elements are performed to ensure operating time is the same as what has been recorded in the database during the last commissioning or maintenance check.

Channel failure alarms and relay failure alarms are also verified by simulating a dc power supply failure through powering down the devices.

3) System

With any maintenance test performed, testing of the complete protection zone is required. This test is performed as a trip test, as explained previously.

E. Lessons Learned

1) Multiplexer Interface Issues

Although relay and multiplexer manufacturers are required to adhere to the same standard, it is sometimes discovered that minor deviation between products does occur because manufacturers interpret the standard differently, particularly under unusual or marginal operating conditions. As a result, careful consideration must be applied when selecting relays and multiplexers.

One of the common issues experienced with IEEE C37.94 is that the optical levels, as well as optical margin, provided by manufacturers may not be compatible for single-mode fiber. This is because usage of single-mode fiber has been added to the IEEE C37.94 standard after the original publication. In some cases, because of the inconsistency in the optical level generated and the optical sensitivity, the 87L relay will lose packets.

Another issue is that relays may respond differently in the case of a communications failure. For example, upon a communications loss in the receive channel, some relays immediately cause a retransmit of the frame. This, in turn, causes the buffer in the multiplexer to fill up and lock up the channel. On the one hand, the relay should not be required to retransmit a frame upon a communications failure in the receive channel. On the other hand, the multiplexer should not enter a lockup mode when the buffer fills up. In this case, there is interdependence between the relay and the multiplexer, with the former causing the latter to fail, and the issues go undiscovered until the specific relay and multiplexer are connected together. This type of issue is best resolved in the certification process when products are evaluated for interoperability with utility-specific system equipment. As issues are identified, the certification tests should be expanded so that the same problem does not reoccur.

2) 87L Channel Asymmetry

Channel asymmetry can occur if the SONET/SDH network is not properly designed and configured. Buffers, unavoidable in a communications network for multiplexing and demultiplexing, can also result in asymmetry in the communications network [2]. It may be beneficial to determine the maximum available buffer size in each communications device in order to determine the worst-case asymmetry, assuming a device malfunction, such as firmware deficiency.

Because most multiplexers do not monitor channel characteristics at the DS-0 level, the only way to monitor and alarm for asymmetry is by the end device—the 87L relay itself. This alarm, if available, should be brought out to signal asymmetry issues to the operator as a trouble alert such that it does not remain hidden and go undetected until the relay misoperates. Measuring channel asymmetry requires absolute time (GPS) connected to both relays of any given channel. These time sources must be of adequate quality and installed, commissioned, and maintained properly in order to prevent spurious asymmetry alarms.

3) Relay Alarms

Microprocessor-based relays can detect a significant number of internal problems and channel problems using built-in self-diagnostic algorithms. This capability can dramatically improve protection availability because problems are immediately detected, allowing for quick remediation.

The master/slave mode of 87L protection is one important aspect of alarming. In the case of alarming, the 87L relay operates as a system with dependency on remote terminals. Upon a communications failure with a three-terminal application, the relay will fall back to the master/slave mode and protection will not be compromised. The ability to operate in a slave mode actually improves the availability of the protection. However, relays presently used by HONI lack the ability to alarm for partial 87L failure (master/slave mode) versus a complete 87L failure. This is important so system operators can properly assess the availability of the protected line. As a result, custom logic is required to alarm protection trouble versus protection failure. Some newer relays provide much more precise indication of the 87L state. For instance, the relay can provide specific indication that it is operating in a master/slave mode and is capable of tripping because it is communicating with a master. It can also provide an indication that it is blocked by a remote relay that has a self-test error.

F. Shortcomings of Existing Methodologies

1) Outage Scheduling Issues

The existing methodologies in testing are able to evaluate the 87L as a system, and because the 87L protection is blocked at all terminals, human errors in causing unwanted trips are reduced. The downside is that the existing methodology requires the complete 87L protection to be out of service during routine maintenance. In some cases, an outage can be canceled or postponed because of operating limitations or problems in the redundant protection. Another related issue is the increase in scheduling effort required to ensure that testing staff are available at all terminals. If one member of the testing staff becomes unavailable at the time of the outage, then the entire outage must be rescheduled. The consequences of a canceled outage are no different for a line differential or line distance scheme in this regard.

Utilities in general need to weigh personnel and scheduling requirements for testing efforts against power grid operating constraints.

2) Limited Test Features

Relay manufacturers tend to develop test methodologies with a focus on what the end users are required to complete in order to commission and maintain the relays. As a consequence, end users are often required to invent methods and possibly build some test features into the relay using relay programmable logic in order to deal with real-life operational constraints. As a result, significant costs are associated with maintaining good testing documentation, not to mention the cost when an inadvertent trip occurs.

It would be beneficial for manufacturers to provide integrated test features, especially for 87L protection schemes. Examples of such features are described in Section VI. This will help significantly in reducing the cost to the user and the danger of inadvertent trips. It would be very advantageous to have the capability to simulate the IEEE C37.94 data stream for the purpose of investigating communications problems, because this capability is not available in a standard telecommunications test set.

3) *Underutilization of Operation Records*

Operation records have often been overlooked as a means to reduce the amount of maintenance effort in the relay or as a substitution to performing trip testing. If protection has been called upon to operate prior to the next maintenance schedule, a question arises as to what is required to be maintained. Do we need to verify the zone with trip test? Often, careful analyses are performed upon operation of the relay, using event, oscillography, and fault records. Using these data, the protection engineer can determine such things as the operating time of the protection, total clearing time, impact of the channel delay, margin between the fault current and minimum pickup setting, and location of the fault loci on the operating characteristic of the differential element.

As such, the complete protection zone has been verified. In addition to the self-monitoring capability available in the relay, it may be sufficient to say that maintenance can be rescheduled for a later date. One important benefit of this approach is that there is no danger of human errors causing an unwanted trip when analyzing records to verify the state of the scheme. This cannot be said about actually testing the scheme to prove it works correctly.

VI. TEST FEATURES INTEGRATED INTO 87L RELAYS

Some 87L relays provide a number of built-in functions to aid testing, continuous monitoring, and troubleshooting. These functions are often used in field testing and during ongoing operation of the 87L schemes.

A. *87L Communications Monitoring and Reporting*

Statistics that reflect the status and health of the 87L communications channel are critical for many maintenance and troubleshooting activities. The current differential relay is often the only source of this information within the substation. Relays provide these statistics in the form of real-time data or a downloadable report. Three classes of data can be found in such a report.

1) *87L Scheme Configuration Summary*

This information is needed to confirm that each relay has been configured as required for the communications channel and timing source to which it is connected. Comparing the data from all relays that participate in the differential zone confirms that the configurations are correct and consistent. These data will include device-specific information, such as the firmware version, 87L ports, and channel types (EIA-422, G.703, and IEEE C37.94). They will also contain application-specific information, such as the number of line terminals,

local and remote relay addresses, and current data synchronization method (channel based or external time source).

2) *Present Relay Status*

These data provide feedback on the present state of the differential element. They include the operating mode of the 87L element (master, slave, nonoperational, or in test). Channel synchronization status (high, low, or not synchronized) and the health of external time sources can also be included. Additional channel monitoring and alarming, such as high count of lost packets, high channel latency, or high asymmetry, may also be available.

3) *Long-Term Channel Statistics*

Long-term channel statistics provide a historical view of the condition of the channel. This is essential for detection of incipient or intermittent problems. Relays may accumulate the number of packets lost over the previous 24 hours. Maximum values for round-trip channel delays, channel asymmetry, and rate of packet loss, along with the time and date of the occurrence for each, can be tabulated. Channel usage can be monitored in redundant channel applications—providing the percentage of time that the main and backup channels are active.

A novel feature of some newer relays is the ability to compile histogram data for important statistics. Histograms provide an alternative way of monitoring channel behavior. Measurements are sorted over a range into a distribution, which represents the frequency of the measurement over time. For instance, the measurement of round-trip channel delay may be subdivided into 10 increments over a range of 0 to 20 milliseconds. The histogram tabulates the percentage of time that the measurement falls into each of these increments. On inspection of the histogram, we may note, for example, that the round-trip delay is between 2 to 4 milliseconds for 85 percent of the time and 15 to 20 milliseconds for 15 percent of the time. This can indicate that the channel is regularly switching from a low-latency path to a higher-latency path and working in the higher-latency path for 15 percent of time.

B. *Loopback Test*

During commissioning, a loopback test can be carried out to confirm the integrity of a portion of a communications link between two relays. During troubleshooting, a loopback may be placed at various locations in order to isolate a failure. Current differential relays facilitate loopback testing by providing statistics during the test. In order to do so, relays must substitute the remote relay ID (expected receiving address) with the local relay ID (transmitting address) in order to allow the relay to talk to itself (the relay ID or address is introduced to prevent accidental cross-connection of wrong relays, including a loopback [2]). Subsequently, communications or metering commands can be carried out to monitor communications statistics or to confirm that differential quantities received on the channel are identical to those transmitted.

C. Metering Report

Current differential relays also provide real-time data or reports that include key calculations associated with the differential element. These include differential and restraining signals, Alpha Plane operating points, or compensating (calculated) charging currents. These values are typically provided for both the phase (87LP) and sequence (87LQ and 87LG) differential elements. The data can be monitored while the relay is connected to another relay over a healthy channel or during a loopback test. The inputs to the differential element, which are used to derive the differential quantities, may originate from secondary injection or from on-load currents and voltages coming directly from the CTs and VTs.

The data obtained in the metering report allow testing staff to confirm that the relay is calculating differential quantities as expected for the particular settings applied to the relay. This is especially valuable for charging current compensation or in-line transformer applications.

D. Multiterminal Test

The multiterminal test verifies the operation of all relays in the 87L zone and their associated communications channels as a complete system, as would be done during acceptance or commissioning tests. The provisions that are incorporated into the relay to support this test are minimal, limited to rerouting the outputs from the phase and sequence elements to a test output for convenient monitoring. The multiterminal test concept is shown in Fig. 2.

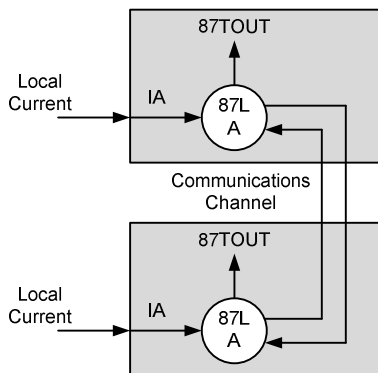

Fig. 2. Multiterminal test concept (Phase A shown)

Currents are injected simultaneously into two or more relays that participate in the zone. Manipulation of these currents allows the differential characteristic to be checked in all relays. A way to control the timing (or phase relationship) between the currents injected at different locations is required to make this test practical and meaningful. Waveform playback can also be carried out using the multiterminal test. This approach is applicable for any number of terminals.

E. Single-Terminal Test

The single-terminal test is used to check the characteristic of the 87L element in a single relay. The test takes advantage of the phase-segregated nature of the current differential element. In the single-terminal test, one of the local current inputs is used by the relay when the relay is put in this test

mode to simulate the current normally coming from the remote terminal. For instance, when carrying out a test of the 87LA element, the local Phase A current is simulated by injecting current locally into the current Input A, and the remote Phase A current is simulated by injecting into the current Input B. In this way, the tester can locally manipulate the local and remote currents, allowing the entire characteristic to be probed during the test. The single-terminal test concept is shown in Fig. 3.

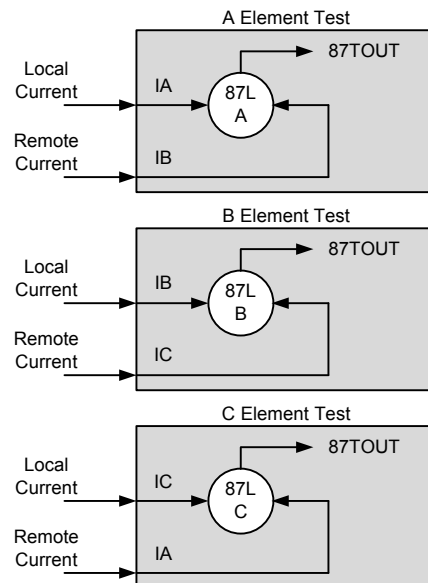

Fig. 3. Single-terminal test concept

F. Comparison of the Multiterminal and Single-Terminal Tests

The advantage of the multiterminal test is that it tests the entire current differential zone as a single system, including all relays, their settings, the interconnecting communications channels, and associated terminal equipment and timing sources. For example, channel latency will directly impact the speed of the differential element, and this will be captured during the multiterminal test. We must keep in mind the limiting factor that this test only confirms overall system health at the time of testing. It is well-known that communications problems may often be intermittent in nature, and channel quality may be good at the time of the test.

Another advantage of this test is its capacity to verify complex applications, such as charging current compensation and in-line transformer operation, because in these applications, the currents and voltages from all phases are coupled in the equations for the various differential elements (87LA, 87LB, 87LC, 87LQ, and 87LG).

The advantage of the single-terminal test is that it does not require coordinated action by multiple test crews located in remote substations using time-synchronized injection test sets. It allows for a verification of each relay in succession. Communication with other relays is not required for this test. Because the single-terminal test only requires local current injection, the remote relays can remain in service, continuing to protect the line via backup distance elements (this yields

benefits in three-terminal applications and applications to tapped lines, allowing to feed some loads during testing and avoiding a complete line outage). Because the local relay is under test, the local breaker(s) would be open during the test at this terminal. The differential element is effectively disabled at all terminals whenever a single-terminal test is enabled.

For the purpose of routine maintenance, a single-terminal test carried out at each of the relays making up the differential zone combined with a check of the communications and on-load checks can be considered as a good alternative to multiterminal testing.

G. Additional Considerations for Integrated Test Features

Experience shows that a significant number of inadvertent trips occur during relay testing. Integrated test features have a significant capacity to reduce these undesired occurrences.

The tests described previously in this section can be combined into a comprehensive test mode provided as part of relay functionality.

The general philosophy and extent of the test mode will likely differ between various relay models. In one approach, enabling the test mode reroutes the output of the differential element from the tripping logic to a dedicated test bit. This bit can be routed to a spare output contact. Test bits are automatically transmitted to all remote relays, effectively blocking their differential elements. In addition, the relay alarm contact asserts, notifying the system operators that testing is in progress. Isolating the differential signals also allows each phase to be checked without concerns that different phases, sequence differential elements, or protection functions not currently under test are operating at the same time. This results in unambiguous test results. A side benefit is that temporary settings do not need to be applied to disable functions not under test. Similarly, the differential element can be inhibited (effectively disabled) within the test mode, allowing other protection functions to be tested. It is possible to argue that a drawback of this approach is that testing the differential characteristic in isolation does not verify the entire differential element as designed.

Modern current differential elements will typically include supervising auxiliary logic, such as a disturbance detector [2]. Within an integrated test mode, this logic may be bypassed, thereby removing another potential source of ambiguity from the test results.

VII. CONCLUSION

Field testing of 87L schemes poses some unique challenges compared with other line protection schemes because it relies on high-speed data communications between substations. This means verifying compatibility and testing relays and communications equipment in a setting where the device location and the origin and destination of data are tens or hundreds of miles apart.

Even though standard communications interfaces are used between relays and communications devices, compatibility can still be an issue. Type testing and certification testing play

an important role in verifying compatibility under all practical conditions to avoid confusion and lost time when testing in the field.

Prior to handing 87L channels over to protection engineering, communications departments carry out channel testing, albeit using relatively generic approaches. These tests can and do discover issues but are not necessarily a guaranteed proof that the channel will meet all of the requirements for 87L protection, particularly over extended periods of time.

As a result, the 87L channels are often rechecked by the protection group using actual relays to verify error-free communication (as reported by the relay built-in channel monitoring features) over a reasonable period of time, such as 24 hours or longer.

Furthermore, because communications networks evolve because of growth, maintenance, temporary configuration, channel and equipment outages, and so on, it is beneficial to monitor the channel on an ongoing basis after putting a new 87L scheme in service. Configuring channel monitoring alarms in 87L relays and multiplexers and treating the alarms as critical should be a preferred practice.

Multiterminal testing of 87L elements emulates the actual operating conditions but calls for test personnel at multiple sites and the means to synchronize the injected currents. The latter is accomplished by using GPS-synchronized test sets, but regular test sets can also be used in combination with remote current metering capabilities of the relays under test. Generally, an end-to-end test provides a superior and more comprehensive system evaluation.

Single-terminal testing of 87L elements allows the testing of 87L relays one site at a time, eliminating the need for multiple crews and synchronized test sets and reducing the complexity of having to coordinate test activities between multiple sites. In the case of multiterminal and tapped lines, single-terminal testing can be performed without taking the line out of service or relying on the redundant protection system. Although the single-terminal test is simpler to carry out, it is not, on its own, an equivalent substitute for an overall system test.

Security when testing 87L schemes is an important consideration—there is an increased danger of unwarranted trips through failure to isolate the remote relays from their tripping circuits, manipulation of the communications circuits when testing communication or relays, misunderstandings between test crews working at different sites, and so on. The 87L relays can enhance security when they support built-in test features (test mode).

The overall test plans for initial commissioning should take advantage of the manufacturer tests and built-in relay self-monitoring. We can reduce the amount of testing in areas that are much less prone to problems and focus on the unique challenges of testing 87L schemes. By the same logic, the periodic maintenance tests can be considerably reduced when applying channel and relay monitoring functions, attending to the relay and communications alarms, and routinely reviewing natural scheme operations, as well as relay records pertaining to power system and communications events.

VIII. APPENDIX A: REVIEW OF VARIOUS RELAY TESTS

This appendix briefly reviews the following three major categories of relay tests:

- Design and manufacturing tests
- Product certification tests
- Field tests (commissioning, routine maintenance, and troubleshooting)

Understanding the purpose and scope of the tests performed prior to the field tests is important because it allows for adjusting test plans for efficiency in terms of both time and effort, as well as minimizing the number of installation deficiencies left uncovered.

A. Design and Manufacturing Tests

These tests include type, functional, validation, and manufacturing tests and are designed to stress the hardware, validate the firmware and associated software, and verify that the equipment has been manufactured as designed.

1) Type Testing

Type tests are also commonly referred to as standard compliance or conformance tests. These tests simulate harsh, infrequent, but conceivable real-world events. Protection equipment must not only survive these conditions but must operate error-free during the occurrence of these events. This is critical because environmental interference, such as electrical noise or ground potential rise, can be generated by a fault. Examples of such disturbances are lightning strikes, earthquakes, electromagnetic interference, severe temperatures, and power supply voltage sags, to name a few. Commonly simulated tests include electrical power disturbances, vibration, electric and magnetic field immunity, high-voltage static discharges, and extreme hot, cold, and damp-heat conditions. The magnitude and frequency of the disturbance applied in each simulated test are purposely harsher than we would expect to find in common installations. For the purpose of conformity, various standards organizations (i.e., IEEE, IEC, UL, CSA, and CE) have defined how each test is conducted and the severity of the disturbance, depending on the end-use application. In certain instances, utilities have also developed their own tests and defined pass or fail criteria for these tests. Manufacturers may include these tests in their type testing program as well.

Equipment is often tested above and beyond the standards (margin testing) to ensure that future manufacturing and component tolerances do not lead to equipment vulnerabilities.

In short, the purpose of type testing is to demonstrate that the design is capable of operating under adverse environmental conditions. The quality of a design is judged by the margin by which the device exceeds the required standard.

It is important to recognize that type tests verify the design and not a particular article manufactured. Good design with margins improves the manufacturing quality and yields, as well as actual performance in the field, but other tests are required to test specific articles used in any given installation.

2) Functional Testing

These tests are conducted to verify each individual device function, such as protection, automation, metering, recording, communication, and so on. The tests are designed to verify that what has been built (including the code) agrees with what has been designed. These tests also verify the characteristics of a particular protection function (e.g., the shape of the mho impedance element or the inverse-time overcurrent element).

These tests verify both the quality of the design as a whole and the specific article manufactured (at least partially). To understand the latter, it is important to realize that device firmware is perfectly reproducible. This means that each copy loaded on a given article is exactly identical with the firmware as released. Therefore, functional tests performed on the released version of firmware prove the firmware that runs on each article manufactured. This benefit does not apply to hardware, and therefore, each article must be checked from the hardware perspective. An ever-increasing portion of microprocessor-based relay functionality is contained in firmware, not hardware, making functional testing an important proof of the actual quality of articles manufactured. As a result, the scope of functional testing in the field can be drastically reduced.

3) Validation Testing

These tests are designed to check the robustness of the design and determine the speed, sensitivity, security, and operation limits of protection elements during different power system conditions. These tests determine how well protection equipment operates in a real-world environment. Validation tests are often run before any algorithm or logic is even coded in relay firmware, at the research phase using tools like MATLAB[®] or Mathcad[®] for relay algorithms and Electromagnetic Transients Program (EMTP) or Real Time Digital Simulator (RTDS[®]) for simulation of power system events.

Validation testing often takes the form of a system test. For applications that require several relays to protect the zone, such as transmission line protection, the test is designed to check the operation of these relays in concert. In the case of 87L validation testing, relays are interconnected through a communications network, along with equipment for simulating channel impairments and events. Again, in the specific case of the 87L, the relays can apply external time sources for data alignment, and therefore, various problems are simulated with respect to these sources during the validation test.

Usually a power system simulator is used to generate real-world current and voltage waveforms to all relays simultaneously. Scripts are developed to cycle through ranges of fault types, fault locations, fault characteristics, source-to-line impedance ratios (SIRs), and fault and switching incidence angles. In the case of testing 87L schemes, these scripts also include channel interruption and switching, communications bit errors, invalid time codes from external

time sources, and many other events related to communication and timing. Validation testing measures both dependability (internal faults) and security (external faults, power swings, power grid switching events, communications events, and so on). The goal is to identify any hidden algorithm weakness under worst-case conditions before the relay is released for production.

Because protection algorithms are embedded in firmware, which, in turn, is perfectly reproducible, there is no need to revalidate the performance during field testing of specific articles to be installed or already in operation.

4) *Manufacturing Testing*

When a research and development department is satisfied that a new protective device is ready for use, the hardware design and firmware are given to a manufacturing department. The manufacturing department verifies that the hardware design can be faithfully replicated by building a large number of units (known as pilot units). Each pilot unit is inspected carefully to ensure that it is a faithful replica of the original. Firmware is then loaded into each unit and verified as a complete embedded device. Finally, the units are tested for accuracy and functionality. When the manufacturing processes are fine-tuned and the pilot units pass inspection, the manufacturing department is ready to build these units en masse. At this time, the product is made commercially available.

Permanent manufacturing quality measures are kept in place to ensure that each article shipped is a faithful replica of the original design. This is to account for component tolerances, component failures, changes in the manufacturing process, drifting of manufacturing equipment tolerance, manufacturing equipment failure, changes in the supplier chain, and, last but not least, human errors. In this context, the automation of manufacturing and repeatability of manufacturing processes are very important. Still, permanent control mechanisms are indispensable. These control mechanisms take the form of inspections, environmental stress screening, and other methods of finding hidden failures before the product is shipped.

When a piece of protection equipment leaves a manufacturing factory, it has been designed and tested to survive the harsh conditions of a substation, its functionality and characteristics have been verified, and it has been proven to be fit for the purpose as defined by the manufacturer.

B. *Certification Tests*

Many utilities, end users, or even national laboratories require a new protective device to pass a series of tests on a test system of their choice before the protective device is certified for use on their power system. These tests are intended to verify that the protective device meets their specified requirements. To be certified, a protective device must operate correctly while being subjected to a series of simulated faults on the test system. These tests are therefore similar to the manufacturer validation testing but are more specific to the utility's own power system, communications equipment, application philosophy, and so on. These tests are

not only intended to verify that the protective device will operate correctly on the user's system but are also intended to educate the user on how to set and apply the device correctly.

In addition to these tests, some users subject the device to a different series of environmental or type tests. Should a protective relay meet all the user requirements, the device is deemed fit for use on the power system.

It is important to realize that certification tests prove a given relay model and associated hardware, firmware, and software revisions. They do not prove that a given article to be installed or in operation meets the requirements. The latter is the role of field testing.

IX. APPENDIX B: FIELD TESTS

These tests are performed in the field on devices installed in their natural environment (panel or rack mounted, wiring, test switches, and so on) and interfacing with actual systems (CTs, VTs, communications links, and so on). The working environment for the field tests is less convenient and controlled compared with bench testing at the manufacturer or in the user's laboratory.

These tests can be categorized as commissioning tests (to verify the initial installation), maintenance tests (to check if the installed scheme continues to work properly), and troubleshooting tests (to find the root cause of problems and prove solutions). These three categories overlap to a certain degree, but we review them individually.

A. *Commissioning Tests*

Very seldom is a protection scheme composed of a single protective device. Typically, a protection scheme is made up of a collection of different relays, switches, meters, alarm panels, disturbance recorders, communications systems, and so on.

Considerable engineering effort, time, and money are spent designing a protection scheme. This includes application design, settings, entry of the configuration parameters into programmable devices, wiring, and so on. The majority of these engineering, drafting, and construction tasks are unique to a given installation but may be significantly managed through development of standard designs and commissioning procedures.

Therefore, once the protection equipment has been installed in the substation and connected to the required equipment, such as the primary plant, communications equipment (if required), and instrument transformers, the integrity of the overall protection system (scheme) must be verified. This is known as commissioning.

Commissioning begins by dividing the protection scheme into different subsystems (such as the wiring, primary plant, and protection panel) and dividing the commissioning tasks into different stages of progressing scope and complexity. This is done so any abnormality or issue can be located as rapidly as possible and, if a failure occurs at an advanced stage of commissioning, the testing staff know exactly where to begin looking for the problem.

Testing staff begin the first stage of commissioning by verifying that the correct connections or wiring has been made by comparing the actual connections or wiring with the design schematics. At the same time, the primary plant can be commissioned, because these two tasks are autonomous to one another. Wiring should be checked all the way from the primary equipment (yard) to the protective device or end point, across a series of point-to-point wire connections.

The second stage is to verify that all primary plant devices (such as circuit breakers, disconnect switches, and tap changers) can be tripped from protection, as well as controlled via local and remote control and that they operate as expected.

Testing staff then verify that the correct settings have been applied and, in the case of a numerical relay, that the relay has the correct version of firmware.

Once this is done, the protection scheme is ready to be tested by applying analog and/or digital test signals to represent different system conditions, such as a fault, breaker failing to open, or temperature alarm. The test signals should be injected via the test blocks. This not only rechecks the wiring from the test blocks to the protective device but also checks that the test block shorting links are correctly located on the test blocks. Again, testing staff test and verify across a different series of connections to make sure there are no spots left unchecked.

Nominal voltage and current are injected into the scheme and verified using the measuring functions in the protective device. Testing staff verify that the measured currents and voltages have the correct magnitude and phase relationship to each other. Many numerical relays measure both the primary and secondary quantities. Both of these quantities should be checked because this verifies that the wiring is correct and the relay measures correctly, and in addition, it verifies that the CT and VT ratios have been entered correctly as settings.

Once testing staff have verified that the protective device is measuring correctly, the scheme is tested for different fault scenarios. Testing staff verify that the actions taken by the protection system are correct and executed in a timely manner. For instance, for an in-zone fault, the scheme issues a trip and the correct breakers are opened and reclosed, if required. All this is done in the expected time frame. Also, for schemes that support single-pole tripping, checks are made to ensure that single-phase faults only trip the faulted breaker pole.

While verifying the correct operation of the scheme, testing staff also check that the correct indications are sent to SCADA and that the recordings match the event. The verification of the event reports is a very important step—not only are the event records used to explain operations of the protection scheme at a later stage, but they can be used in lieu of periodic maintenance.

It is important that the test quantities applied to the protective relay during commissioning be representative of actual power system events. Often, this is not the case, and somewhat artificial quantities are used. This has led to unexpected operations of protection schemes, confusion, and lost time during testing. A further advantage of using quantities representative of the actual power system is that

these quantities can be used to verify that the correct settings have been applied to the scheme and/or that testing staff understood how to set the relay properly. For example, if testing staff apply a Zone 1 fault and the relay declares the fault as Zone 2 and operates in the Zone 2 time frame, testing staff know that the applied settings are incorrect. If, on the other hand, the relay identifies the fault as Zone 1 and the fault locator calculates the location correctly, the testing staff's confidence in the scheme, the protective relay, and the settings is much greater.

It is important to realize that in commissioning testing, the aim is not to verify the characteristics of the relay, because this has been done in functional and certification testing, but rather to test the performance of the overall protection scheme, given specific articles used to make up the scheme, specific workmanship of the installation, and specific settings applied.

Protection schemes that include adaptive protective relays require the scheme to be tested under different contingency conditions, such as when the protective relay switches to a different settings group or changes its operating logic based on external conditions (e.g., a line differential relay with integrated backup engaging distance backup elements, if the communications channel fails). A comprehensive test plan should include ways to force the scheme to all of these operating modes and test the adequate functions while in the specific mode. Adaptive protection algorithms may be difficult or impossible to test in the field with the conventional test sets available (e.g., an algorithm that learns the variation of 3I0 over time).

Protection systems that rely on communication from a remote terminal require that the overall scheme be verified and tested. This often means that testing at different line terminals (substations) must be coordinated and synchronized. In this manner, the communications equipment is exercised and the channel characteristics between the different substations verified (latency, BERs, and so on).

Once the entire scheme has been tested and verified, testing staff must ensure that all the test switches are returned to their normal operating position; the lockout relay (if present) is reset; all indications, alarms, and counters are reset; and all the Sequential Events Recorder (SER) and event reports are cleared from the relay. Testing staff must check and verify that all protection settings that were disabled or altered during testing are restored to their required values.

With the integrity and functionality of the scheme verified and all switches and indications in the normal position, the protection scheme can be placed into service.

When the scheme is switched into service, it is a good time to recheck that the protective devices are measuring the correct quantities and no unexpected elements are asserted.

The final stage of commissioning is to ensure that the documentation is up-to-date. Often during commissioning, schematics are updated and settings are changed as problems are found and rectified. These changes need to be reflected in the protection scheme schematics and documentation for the life cycle of the scheme.

Because it is the last test carried out before placing primary equipment into service, we cannot overstress the importance of commissioning. It is essential that the commissioning personnel have a deep understanding of the protection scheme and the system into which it is applied. Commissioning should be detailed and methodical. It is not unheard of for errors that have been overlooked during the scheme engineering or construction to be uncovered during this phase.

B. Routine Maintenance Tests

Maintenance testing is carried out in order to confirm that the protection scheme is still operational and is typically mandated by a regulating body, such as the North American Electric Reliability Corporation (NERC). The question may arise, "What type of testing should be carried out?" Part of the answer depends on whether the scheme has been called into service since it has been commissioned. If a protection scheme has been called into service and an event record is available, careful analysis of the recorded events will determine if the scheme is operating as desired. If the event report indicates that the scheme operated correctly for the system disturbance and all correct output contacts were exercised, the scheme does not require any additional periodic testing because the power system already did this through naturally occurring events. On the other hand, if the scheme has not been called into service since commissioning, it may require periodic testing.

Microprocessor-based relays with built-in metering functions may require only limited routine testing—a simple meter function could be used to compare the measured values with those of the system. If these values agree, we can be assured the relay is functioning correctly when it comes to its inputs. In addition, we may trip the breaker via the protective relays simply to verify the relay output contact, wiring, and breaker trip coil.

Modern protective relays have built-in monitoring functions and features that monitor the state of primary plant apparatus, such as circuit breakers and transformers. These built-in features can be configured to alarm for conditions (such as slow electrical or mechanical operating times) or excessive current being interrupted. This allows a transition from a scheduled maintenance program to a condition-based approach. Because maintenance of the primary equipment and maintenance of its protection schemes are often performed at the same time, the conditions of both the primary and secondary systems can be used to determine the need, frequency, and even the scope of periodic maintenance and testing.

In summary, the goal of routine maintenance is to ensure that the protection remains operational, while, at the same time, to minimize effort and impact to the power system. Self-testing may not, in all cases, be capable of accounting for all factors critical to the relay system operation.

It is worth emphasizing that any testing is a disruption in the scheme operation. Test switches are opened, commands issued to the devices, settings temporarily altered (not recommended but sometimes used), and so on. All these steps carry a danger of human errors. Minimizing routine testing while taking advantage of the self-monitoring functions of microprocessor-based relays not only saves effort and resources but reduces issues caused while testing.

C. Troubleshooting Tests

Should an event report or periodic test of a protection scheme indicate that a protection scheme is not operating as expected, then troubleshooting will need to be carried out.

First, determine what the scheme should be doing, and compare it against what the scheme is doing. From this, formulate a set of hypotheses as to why the scheme is reacting the way it is, and work out methods of how to test each of these hypotheses. Now, by a process of simple elimination, determine why the scheme is not operating correctly.

If commissioning of the protection scheme was done correctly and good documentation has been maintained, troubleshooting of the scheme should prove to be relatively simple and fast. In general, most issues that arise after commissioning are due to problems with contacts, auxiliary coils, disturbances to the wiring, and so on. Should a protective relay fail, it is designed to assert its alarm contact and take itself out of service.

Protection schemes that rely on long-haul communication, such as 87L schemes, especially when using networked channels instead of direct point-to-point channels, can be much more difficult to troubleshoot if problems involve the channel.

X. REFERENCES

- [1] H. Miller, J. Burger, N. Fischer, and B. Kasztenny, "Modern Line Current Differential Protection Solutions," proceedings of the 63rd Annual Conference for Protective Relay Engineers, College Station, TX, March 2010.
- [2] B. Kasztenny, N. Fischer, K. Fodero, and A. Zvarych, "Communications and Data Synchronization for Line Current Differential Schemes," proceedings of the 38th Annual Western Protective Relay Conference, Spokane, WA, October 2011.
- [3] B. Kasztenny, G. Benmouyal, H. J. Altuve, and N. Fischer, "Tutorial on Operating Characteristics of Microprocessor-Based Multiterminal Line Current Differential Relays," proceedings of the 38th Annual Western Protective Relay Conference, Spokane, WA, October 2011.
- [4] Telcordia Technologies GR-253-CORE, *Synchronous Optical Network (SONET) Transport Systems: Common Generic Criteria*, Issue 5, October 2009.
- [5] M. Borrielli, "New Testing Method for Line Differential Relays," proceedings of the International Conference on Relay Protection and Substation Automation of Modern Power Systems, Cheboksary, Russia, September 2007.
- [6] P. Meinhardt, "Improved Possibilities for Testing of Line Differential Protection," proceedings of the Omicron International Protection Testing Symposium (IPTs), Vorarberg, Austria, September 2006.

XI. BIOGRAPHIES

Keith Lee received his bachelor's degree from the University of Alberta in Electrical Engineering and a master's degree from the University of Waterloo in Electric Power Engineering. He is currently employed as a senior protection and control officer with Hydro One Networks Inc. He is actively involved in testing and evaluation of protection and teleprotection equipment. His areas of interest include teleprotection, line protection, feeder protection, and distribution automation.

Dale Finney received his bachelor's degree from Lakehead University and his master's degree from the University of Toronto, both in electrical engineering. He began his career with Ontario Hydro, where he worked as a protection and control engineer. Currently, Dale is employed as a senior power engineer with Schweitzer Engineering Laboratories, Inc. His areas of interest include generator protection, line protection, and substation automation. He is a holder of several patents and has authored more than a dozen papers in the area of power system protection. He is a member of the main committee of the IEEE PSRC, a member of the rotating machinery subcommittee, and a registered professional engineer in the province of Ontario.

Normann Fischer received a Higher Diploma in Technology, with honors, from Witwatersrand Technikon, Johannesburg in 1988, a BSEE, with honors, from the University of Cape Town in 1993, and an MSEE from the University of Idaho in 2005. He joined Eskom as a protection technician in 1984 and was a senior design engineer in the Eskom protection design department for three years. He then joined IST Energy as a senior design engineer in 1996. In 1999, he joined Schweitzer Engineering Laboratories, Inc. as a power engineer in the research and development division. Normann was a registered professional engineer in South Africa and a member of the South Africa Institute of Electrical Engineers. He is currently a member of IEEE and ASEE.

Bogdan Kasztenny is a principal systems engineer in the research and development division of Schweitzer Engineering Laboratories, Inc. He has over 20 years of expertise in power system protection and control, including ten years of academic career and ten years of industrial experience, developing, promoting, and supporting many protection and control products.

Bogdan is an IEEE Fellow, Senior Fulbright Fellow, Canadian member of CIGRE Study Committee B5, registered professional engineer in the province of Ontario, and an adjunct professor at the University of Western Ontario. Since 2011, Bogdan has served on the Western Protective Relay Conference Program Committee. Bogdan has authored about 200 technical papers and holds 20 patents.