

SEL DNA[®]

Distribution Network Automation



Enhance the reliability and efficiency of your distribution system.

- Automatic Network Reconfiguration isolates faulted sections and reconfigures the system without overloading the feeder.
- Volt/VAR optimization supports conservation voltage reduction and power factor correction, which reduces system losses.
- Industry-standard protocols integrate with existing equipment to reduce the implementation time and costs.
- Fault location directs line crews to the section needing repair, reducing outage times.





SEL DNA systems increase system operational efficiency and reduce operating costs to address increasing customer expectations for affordable and reliable electric service. As a leader in delivering scalable, modular distribution automation systems that meet your specific requirements, SEL offers comprehensive engineered systems and provides individual components for utilities that want to build their own systems. Our DNA systems combine fast protection with flexible automation control and communications for a distribution automation solution that makes your system safer, more reliable, and more economical.



Safer

Maintaining the safe operation of the power system is a top priority for every utility. All DNA systems are built with the philosophy that protection is the top priority and includes preserving coordination with reconfiguration. DNA systems also use new methods, such as Arc Sense™ technology (AST), allowing detection of more faults than ever before. AST-equipped substation relays and recloser controls can detect high-impedance faults that cannot be detected with conventional distribution protection.

More Reliable

DNA systems include automated reconfiguration schemes and provide the highest level of reliability by sectionalizing the smallest portion of the system when a permanent fault occurs and maintaining service elsewhere. Automatic Network Reconfiguration allows the distribution system to “self-heal,” keeping the lights on for most consumers and rerouting power automatically around one or more faulted areas. Additionally, fault location technology quickly guides crews to the fault point so repairs can be made and service restored more quickly.

More Economical

Improving the efficient operation of the distribution system is one of the most cost-effective ways to meet the ever-changing demands on the grid. The amount of load on the distribution system is constantly changing, and the stresses this puts on the system will likely intensify with new loads and sources, like plug-in electric vehicles (PEVs) and distributed generation (DG). Volt/VAR control is one of the most cost-effective means to improve distribution efficiency and reduce system losses. SEL DNA systems can include transformer load tap changer (LTC), capacitor, and voltage regulator controls to flatten the voltage profile along feeders. DNA systems can also provide power factor correction and reduce system losses, thus improving the customer experience and reducing energy costs.

SEL Distribution Automation Solutions

Distributed Control With Autonomous Operation

SEL relays and controllers provide built-in automation logic that can be used without communications to automate protection, network reconfiguration, and volt/VAR control. Protection devices apply time coordination for protection and time delays for automation, using local sensing and control.

This system will:

- Improve reliability with Automatic Network Reconfiguration.
- Reduce system losses and improve power quality with volt/VAR control.
- Speed up fault location using faulted circuit indicators (FCIs) with visible indication to direct line crews to faults.

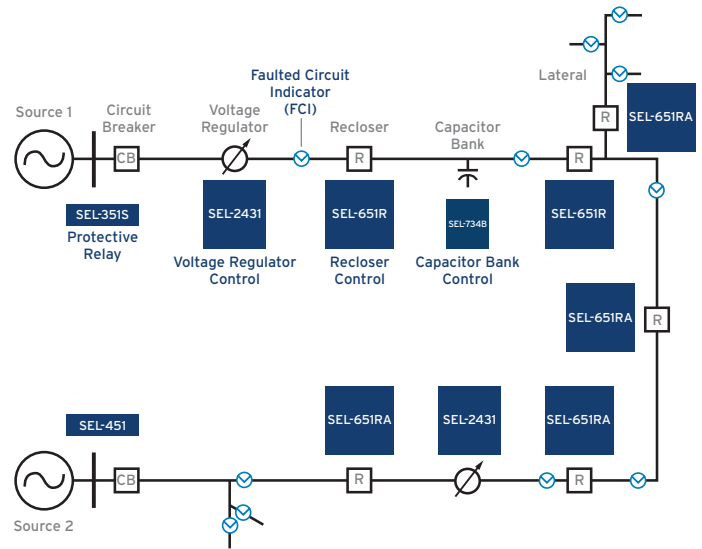

Autonomous device operation provides distributed control without communications.

Distributed Control Using Communications

The addition of communications improves not only the coordination of protection between devices but also the automation of switching to reconfigure the system. Automation logic in each line device allows it to make intelligent decisions based on fault detection and the presence of voltage on one or both sides of the recloser.

In addition, this system will:

- Allow viewing and changing of settings remotely and securely.
- Automatically collect data from devices, including metering, monitoring, and diagnostics data.
- Provide the fastest device coordination using fast peer-to-peer communications to reduce outage times.

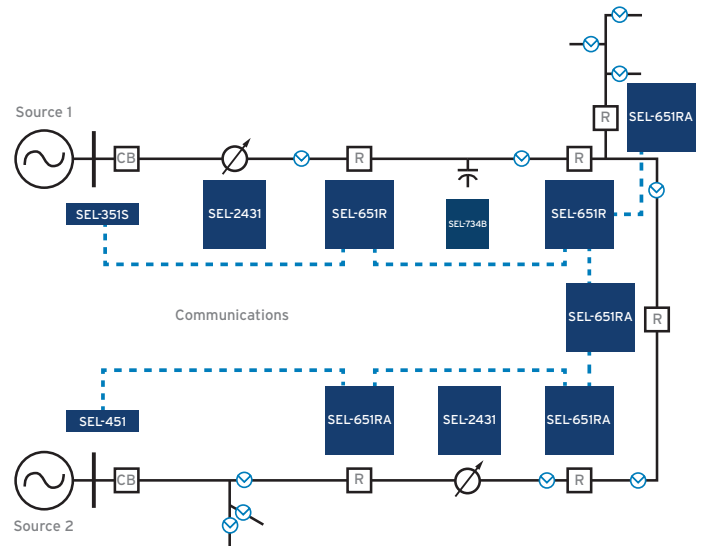

Communications improve coordination and reconfiguration.

Centralized Control

Centralized control using one or more distribution automation controllers for feeder automation is useful when coordinating a large or very diverse distribution system. The addition of intelligent line devices, such as communicating FCIs, provides accurate fault location.

In addition, this system will:

- Provide fast protection and the highest degree of automation, including miscoordination detection and control.
- Optimize volt/VAR control for conservation voltage reduction, transmission VAR support, and voltage reduction schemes, even after reconfiguration.
- Reduce cycling of devices with coordinated control.
- Provide information to SCADA or DMS systems so operators know the status of the distribution system.

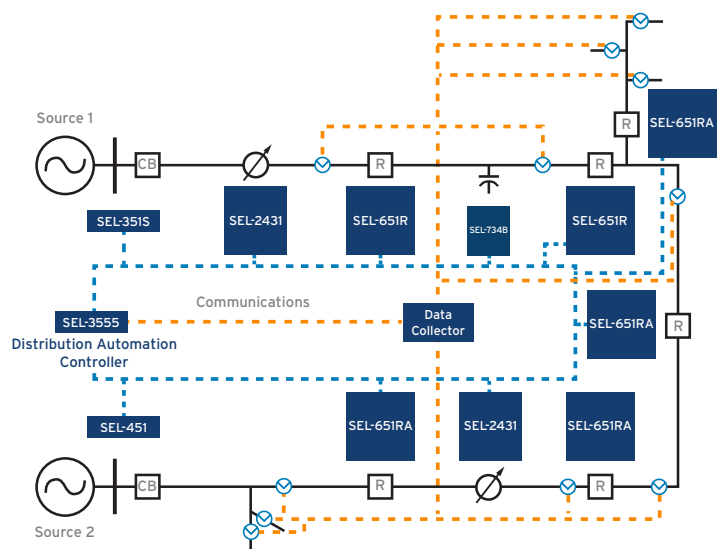

Advanced distribution automation system with wireless FCIs provides the most comprehensive automation and control.



Feature

Fault Location Isolation and Service Restoration (FLISR), Also Known as Automatic Network Reconfiguration

Coordination Preserved With Reconfiguration

Simultaneous Multifault Accommodation

Overload Mitigation

Miscoordination Detection and Correction

Adaptive Volt/VAR

Conservation Voltage Reduction

VAR Support

Control of Inverter-Based Generation

Email and SMS Alerts

High-Impedance Fault Detection

Centralized Engineering Access

Automated Event Collection

Cybersecurity Using Encryption and Automated Password Management

Fault Location

SEL Distribution Automation Solutions Comparison

Distributed Control Autonomous Operation	Distributed Control Using Communications	Centralized Control Using DNA	Benefit
Yes, limited to local sensing	Yes	Yes	Detect and isolate a permanently faulted section of network, and restore power to remaining customers.
No	Yes, limited to simple topologies	Yes	Protect equipment without compromising safety. Eight settings groups per recloser control ensure proper protection settings are always used.
No	No	Yes	Minimize the number of customers impacted.
No	Yes, limited to simple topologies	Yes	Avoid overloading equipment after reconfiguration. Includes load rebalancing and/or load shedding.
No	No	Yes	Automatically detect and correct for miscoordination.
No	No	Yes	Flatten voltage profiles and reduce system losses using coordinated control of transformer LTCs, voltage regulators, and capacitor banks, even after reconfiguration.
No	No	Yes	Reduce energy use during peak demand.
No	No	Yes	Use distribution assets to provide VAR support for the transmission system.
No	No	Yes	Control renewable generation for real and reactive power flow at the point of interconnection.
No	No	Yes	Provide instant notification of events and/or abnormal conditions.
Yes	Yes	Yes	Reduce the chance of electrocution or wildfires by detecting high-impedance faults by using SEL-451 or SEL-751 Protective Relays and SEL-651R or SEL-651RA Recloser Controls.
No	Available	Available	View and/or change settings from your desk.
No	Available	Available	Speed up post-event analysis using ACSELERATOR TEAM® SEL-5045 Software to collect event and Sequence of Events (SOE) data from all relays. Analyze and improve system operation.
No	Available	Available	Encrypt communications and automatically set, change, and restrict user access to each remote device by using SEL-3620/SEL-3622 Security Gateways.
Yes	Yes	Yes	Dramatically improve fault location using FCIs in addition to the relay event reports.

Functionality provided as part of preprogrammed libraries. Three libraries are available as part of a DNA system:

- ANR—Automatic Network Reconfiguration
- DFO—Dynamic Feeder Optimization
- GC—Grid Connect

DNA systems may include a simulation environment for testing settings updates and event response, and for use in training.



SEL DNA Applications

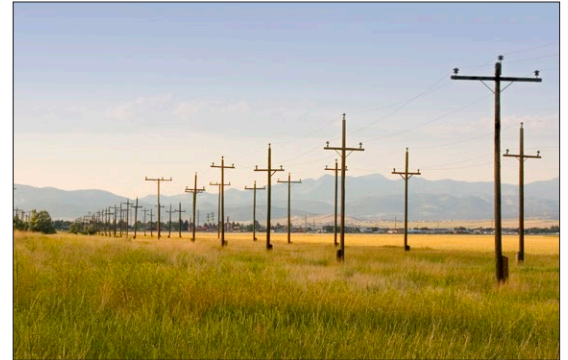

Maximize Uptime and System Efficiency

SEL DNA technology combines fast protection with flexible automation and communications for a customized distribution automation solution that makes your system safer, more reliable, and more economical. SEL DNA systems range from distributed intelligent devices and sensors to wide-area centralized controls. These fast and efficient systems automate all parts of the distribution grid, from neighborhoods to distributed generation sites, and maximize uptime and system efficiency, helping you improve your system reliability indices.



Automate Substations

The substation is the heart of a fully optimized DNA system. Substation relays, such as the SEL-451 Protection, Automation, and Bay Control System and SEL-351 Protection System, provide the backbone of feeder protection and automation. Substation relays coordinate with down-line protection via communications infrastructure and provide additional protection features, such as SEL AST, which is used to detect high-impedance faults from sources like downed conductors. An SEL distribution automation controller may also be located in a single substation or in multiple substations to coordinate wide-area distribution automation and optimization systems.

ACSELERATOR TEAM, running on a substation-hardened computer like the SEL-3355 Computer, automatically collects event data to visualize, organize, and document assets across the distribution system.



Optimize Volt/VAR Control

In many cases, improvements to efficiency and performance are part of a complete DNA system. Intelligent controls, sensors, and communications systems allow utilities to monitor systems in real time and take actions automatically to maintain stability and reliability. Volt/VAR control is one of the most cost-effective means to improve distribution efficiency. SEL Dynamic Feeder Optimization (DFO), in conjunction with transformer LTC, capacitor, and voltage regulator controls, flattens the voltage profiles along the feeder, maximizing the effectiveness of voltage reduction when it is needed. The SEL-2431 Voltage Regulator Control monitors feeders on a per-phase basis. This allows optimization of conservation voltage reduction schemes by the feeder and on a per-phase basis to further improve efficiency.



Locate Faults

Accurately locate faults across the distribution system using event information from protective relays and reclosers. Further improve fault location by adding FCIs, such as the SEL WSO—Wireless Sensor for Overhead Lines or the AR360—Overhead AutoRANGER®, which are advanced microprocessor-controlled FCIs. Integrating inexpensive FCIs into a DNA solution provides increased information, like load and temperature data, and guides repair crews to the problem location.

Another way to improve situational awareness is to integrate the SEL-FT50 and SEL-FR12 Fault Transmitter and Receiver System into a DNA system. The SEL Fault Transmitter and Receiver System can send fault signals to relays and recloser controls in 6 ms so coordination can quickly adapt. This allows a DNA system to clear mainline faults fast without waiting for fuse coordination on branch circuits. Accurately locating distribution faults and coordinating protection reduces outage times and improves repair crew productivity.



Reliably Integrate Distributed Generation

Protect both the utility and the independent power producer (IPP) when integrating distributed generation into the system. Apply directional protection and simultaneously use different protection settings for faults in each direction.

Another important protection step involves implementing synchronism check during closing. Synchronism check functions protect the system and IPP from the effects of voltage angle differences.

Reliably disconnect distributed generation in less than the two seconds required in *IEEE 1547 Standard for Interconnecting Distributed Resources With Electric Power Systems*. Disconnecting the distributed generation quickly ensures the safety of line crews working to repair a feeder.

Control renewable generation for real and reactive power flow at the point of common coupling using the Grid Connect library.



Automatically Sectionalize and Reconfigure

The ability to quickly detect a fault, isolate a small section of line, and reconfigure the system to automatically restore service to customers is the key to improving service and reliability in every DNA system. Feeder reconfiguration is implemented using intelligent devices that make decisions based on local sensing to automatically reconfigure the distribution system. Adding communications to the system allows much faster operation and a higher degree of coordination and automation throughout the distribution system. SEL recloser controls, such as the SEL-651R Advanced Recloser Control or SEL-651RA Recloser Control, connected to reclosers working as breakers or automatic sectionalizers, and SEL-2411 Programmable Automation Controllers connected to motor-operated switches further enhance automatic feeder sectionalizing and reconfiguration. These capabilities provide the highest level of availability in the distribution system and allow distribution protection at transmission speeds.



Overload Mitigation

A system that enables the grid to self-heal after an event improves service reliability and reduces costs. Automatic Network Reconfiguration from SEL does just that. It sectionalizes permanently faulted segments and quickly restores service to nonfaulted segments, thereby minimizing the number of impacted customers. DNA systems are available with real-time monitoring and reconfigure based on current system demand, allowing for the most optimal configuration as well as ensuring that no equipment is ever overloaded due to reconfiguration. Operators are able to see how the system is configured, to manually intervene, and to reset the base system configuration for extended outages.



High-Impedance Fault Detection

Protect your customers from the dangers of downed conductors and minimize outage times with AST. Poorly conductive surfaces may cause fault current levels that are too low to be detected by conventional overcurrent protection elements. The AST algorithm has been designed to improve the accuracy of the device's detection capabilities. To ensure the accuracy of the high-impedance fault (HIF) detection, the algorithm gathers additional data to make the best possible decision. The patented Sum of Difference Current method uses the rate of change of the current to detect arcs resulting from HIF events, such as downed conductors. Use the AST feature in SEL distribution relays and recloser controls as part of your DNA solution to detect high-impedance faults caused by downed conductors, tree branches leaning against power lines, or dirty insulators to improve safety and restore power quickly.

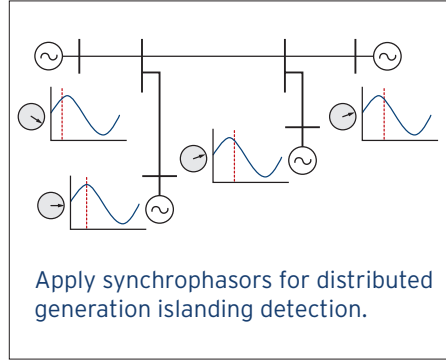

Detect Islanding

Synchronized phasor measurements (synchrophasors) provide a real-time measurement of electrical quantities from across the power system. These measurements can be used for control and analysis of the power system and are included in most SEL distribution control devices.

SEL is a global leader in synchrophasor technology. Advanced, rugged phasor data concentrators and protective relays, coordinated with microsecond-accurate GPS clocks, are capable of transmitting and receiving measurements in real time.

Incorporate synchrophasor measurements and/or control into your DNA system, and leverage the power of up to 60 measurements per second for:

- Increasing situational awareness across the distribution system
- Improving feeder-level control and loading
- Anti-islanding of distributed generation

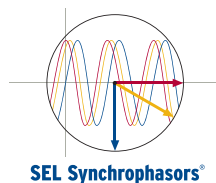

Enhance System Awareness

SEL DNA reduces analysis time with built-in tools and comprehensive self-diagnostics. All relays and protection functions are self-monitoring and record any system disturbance. Events are automatically archived for detailed analysis.

Save time by automatically collecting relay event data from across your distribution system. Using centralized relay event collection and analysis allows you to get to root cause within minutes of an event occurring on the system.

acSELERATOR TEAM Software retrieves event report oscillography from each relay with TEAM Events. With millisecond precision, SEL DNA retrieves SOE records from all relays by using the TEAM Sequential Events Recorder (SER). Based on the relay settings, the event report can contain analog inputs, control outputs, digital inputs, and relay logic variables that can be used for analysis of any system operation.



SEL DNA Components

Enhance the reliability and efficiency of your system by implementing an SEL DNA system.

Start With the Best Protection Relays

In addition to providing outstanding protection for your distribution system and equipment, DNA systems use SEL relays as one of the fundamental building blocks. This allows DNA systems to be economically added to existing distribution protection systems. Common relays used in DNA systems include the SEL-351 Protection System; SEL-451 Protection, Automation, and Bay Control System; SEL-751 Feeder Protection Relay; SEL-700GW Wind Generator Relay; and others.



Use Powerful Automation Controllers

DNA systems can use programming and logic in individual reclosers or relays, or use comprehensive programming implemented in distributed or centralized automation controllers that include real-time monitoring, graphical human-machine interfaces (HMIs), centralized event collection, etc. Using ruggedized Real-Time Automation Controllers (RTACs), such as the SEL-3555 RTAC, or substation-rated computers, such as the SEL-3355 Computer, provides a powerful and reliable distribution automation system.



Integrate FCIs

Both overhead and underground FCIs, such as the WSO—Wireless Sensor for Overhead Lines and the AR-URD—Underground AutoRANGER, can be added to an SEL DNA system. SEL offers both standalone and wireless FCIs that can greatly speed up locating the fault and reduce outage times. Use the SEL Fault Transmitter and Receiver System to send information via the relay or recloser control into your DNA system to improve fault location and situational awareness. The system quickly sends fault signals to accelerate tripping, speed up restoration, and improve safety.



Add Recloser Controls

SEL offers a variety of recloser controls that work with most of the popular recloser systems. Whether you use the SEL-651R Advanced Recloser Control, the SEL-651RA Recloser Control, or the SEL-351RS Kestrel® Single-Phase Recloser Control, an SEL DNA system will reliably sectionalize and reconfigure the system.



Control Capacitor Banks, Voltage Regulators, and More

In addition to using feeder relays and recloser controls, DNA systems can incorporate capacitor bank control and monitoring using SEL-734B Advanced Monitoring and Control Systems, SEL-2431 Voltage Regulator Controls, and SEL-2411 Programmable Automation Controllers for motor-operated switch control. Including these devices provides a more capable system.



Implement Fast and Reliable Communications

Communications play a key role in an optimized distribution network system. DNA solutions from SEL can use MIRRORING BITS® communications for the fastest peer-to-peer communication available; industry-standard protocols, like DNP3 and IEC 61850, to integrate SEL and third-party devices; or a combination of protocols. Integrate DNA systems into your existing SCADA systems. Implement serial and Ethernet radios, managed and unmanaged Ethernet switches, SONET multiplexers, and network management system software, all developed to the same rigorous standards as our protective relays. Developing to these proven standards provides higher reliability for your distribution network communications.

Enhance Cybersecurity

SEL DNA systems implement pragmatic and effective cybersecurity measures that ensure access for authorized utility engineers while preventing unauthorized access and that fit into a larger NERC CIP compliant system. Cybersecurity cannot be achieved by one person, product, or technology. Real system-wide protection starts with the understanding that it takes teamwork to achieve success. SEL believes that combining layered security protection with the efforts of protection engineers, information technology (IT) personnel, and compliance engineers leads to a secure and compliant solution. Power engineers demand the most reliable systems and services for their control and protection settings. Settings cannot be disturbed, cables cannot be switched, and significant latency cannot be tolerated. Engineers must have full access to control their equipment 24 hours a day, 365 days a year. The SEL cybersecurity implementation in our DNA solutions protects these assets, satisfies IT needs, and assists in NERC CIP compliance while enabling power engineers to work efficiently.



SEL Service and Support

Engineering Services

Use SEL Engineering Services to design and implement a complete DNA system that meets your specific requirements. Our experienced team provides solutions that are efficient and economical, including:

- Wide-area distribution automation systems
- Arc-flash hazard studies
- Engineering studies
- Security studies
- Custom panel solutions
- Power system studies and relay settings
- Protection and automation scheme design
- Integration system design, testing, and setting
- HMI design and programming

Real Time Digital Simulator (RTDS®)

Using RTDS technology, SEL provides complete dynamic modeling at the factory, significantly reducing onsite installation and commissioning costs. RTDS technology offers:

- Closed-loop control and protection system testing
- Rotating- and static-load modeling
- System and governor response time testing
- Load flow, short-circuit, motor start, and governor and exciter operation testing and simulation

Regional Technical Support

SEL provides personalized, regional technical support to our customers from more than 100 offices in 24 countries worldwide.



SEL SCHWEITZER ENGINEERING LABORATORIES

Making Electric Power Safer, More Reliable, and More Economical
Tel: +1.509.332.1890 | Email: info@selinc.com | Web: www.selinc.com

© 2011–2017 by Schweitzer Engineering Laboratories, Inc.
PF00273 • 20160725

