

LINAM[®] CR

Underground Current Reset Fault Indicator



Improve system reliability by quickly identifying underground cable faults

- Line-powered fault indicator does not need batteries.
- Leads line crews straight to the fault and reduces the outage duration.
- Factory-set and ready for installation.
- Flexible display configurations fit many applications.
- Economical long-term solution backed with a ten-year, no-questions-asked warranty.



Overview

LINAM CR Underground Current Reset Fault Indicators use continuous load current to automatically reset and maintain readiness to respond to a fault.

The CR features a closed-core CT. This dual-purpose CT harvests energy from the magnetic field generated by the load current while also functioning as a clamp to secure the product on an underground cable.

By using a fault-sensing reed switch that is factory-set and calibrated to a user-selected trip rating, the CR can detect and sense faults lasting as little as 1 millisecond. Faults are indicated on an integral or remote display.

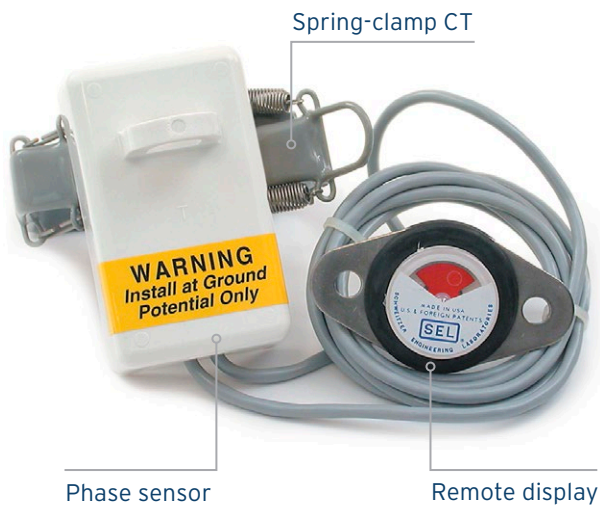

LINAM CR With Remote Display 1CRV

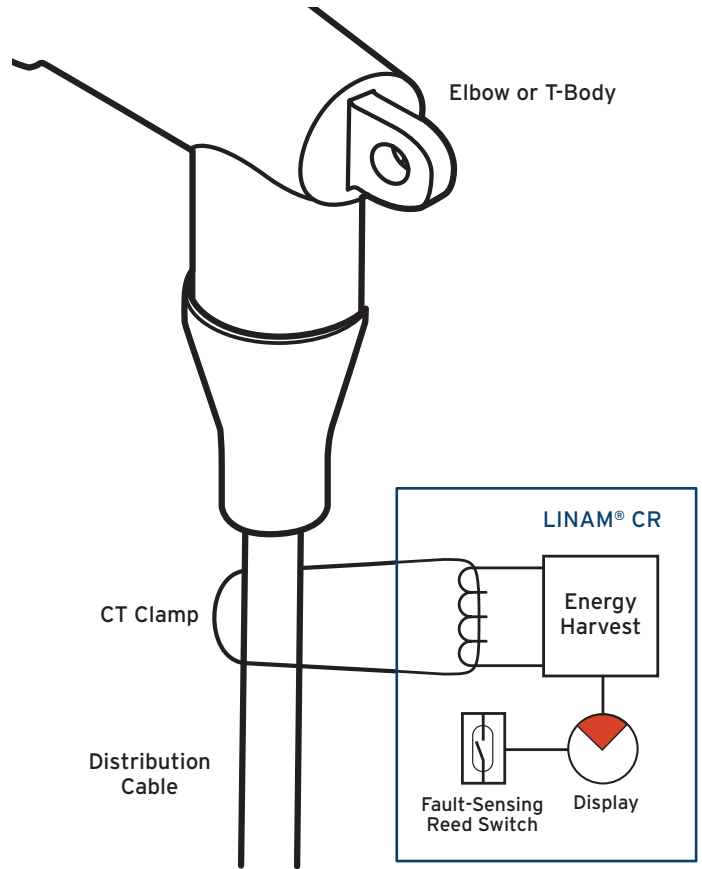

Key Benefits

Reduce Outage Duration

Quickly and efficiently find faults on underground distribution system cables to improve reliability.

Easy Installation

Spring-loaded clamps enable quick installation with standard hot-line tools.

Flexible Fault Status Indication

Choose an integral display for the most compact configuration. Remote displays provide external fault indication to a pad-mounted enclosure and at a vault entrance. An optional auxiliary contact provides status indication to SCADA via your nearby remote terminal unit (RTU).

Improved Productivity

Remote displays eliminate the need to open the enclosure to check the fault indicator status, which reduces the fault-finding time.

Enhanced Visibility

SEL fault indicator displays are highly visible. Choose an integral or remote reflective red target for clear fault status indication. In addition, the fully line-powered design does not require batteries. The BEACON® LED display is offered as a standalone BEACON Bolt® LED or in combination with a mechanical target display. All BEACON LED options feature a hardwired LED that provides the brightest lighted display compared to other solutions in the industry.

Applications

Pad Mount

Install LINAM CRs in pad-mounted enclosures to identify faults in the underground cable between enclosures. CRs help determine where to isolate the fault so you can restore as many customers as possible while the permanent fault is repaired. These fault indicators are ideal for three-phase pad-mounted transformers and three-phase live-front or dead-front switchgear where there is sufficient load current to power the CR.

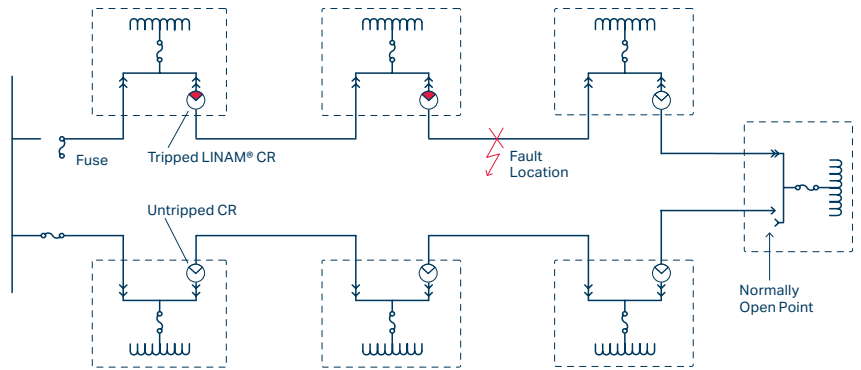

CRs identify the faulted cable section within a loop of pad-mounted transformers that contain a normally open point.

Subsurface

Apply the CR to underground cables within subsurface vaults and manholes to identify faulted cable sections. CR remote displays help eliminate the need to enter vaults to view the fault status. CRs with mechanical target displays are fully submersible and designed to withstand flooded environments. If flooding is common, use CRs with remote mechanical target displays to view the fault status above the water line.

Avoid opening vaults by using the RadioRANGER® Wireless Fault Indication System to view the fault status of the CR from outside the vault.

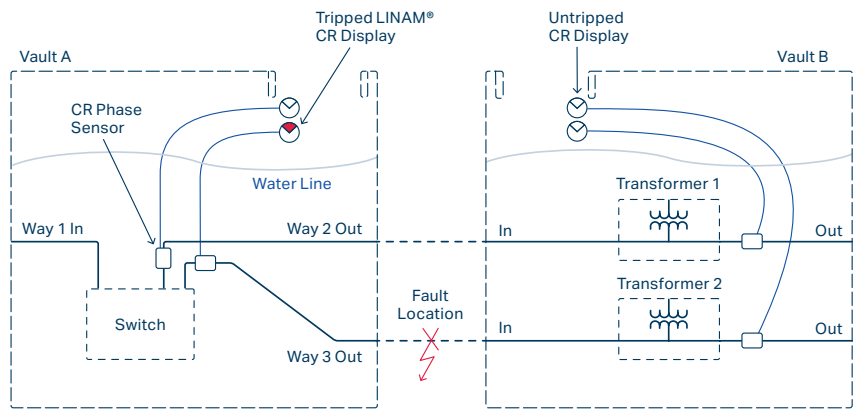

Apply CRs to outgoing ways of switches and transformers to determine if the fault is beyond the installed (or monitored) location.

Cable Preparation and Installation

SEL recommends double-back concentric neutral training, as shown in Option 1. Other acceptable methods include Options 2 and 3, which depict the installation of the fault indicator directly over the semiconductive layer around the cable.

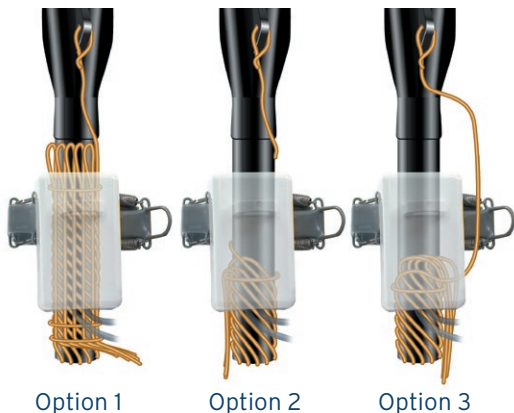

Dimensions

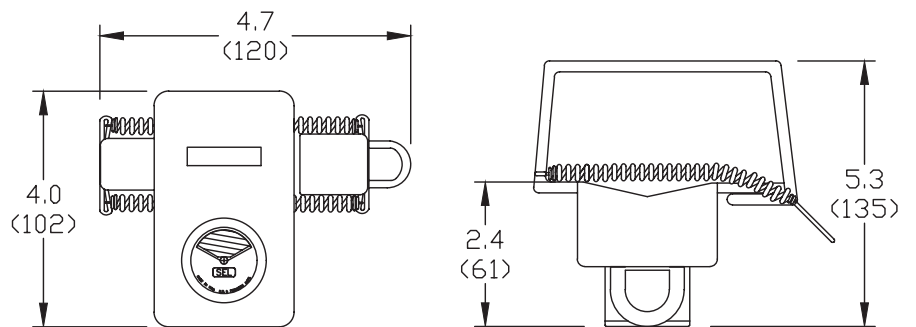

Specifications

General Specifications

Power Source	Mechanical target: Load current LED display: Replaceable battery (standard)—1,200 flashing hours (2.4 Ah, 3.6 V lithium AA cell)
Display Options	Reflective red target Combination target and BEACON LED Tamperproof Bolt or BEACON Bolt LED
Inrush Restraint Response Time	300 ms
Nominal Trip Rating	50 to 1,200 A
Trip Rating Tolerance	±10% (specified at +25°C [+77°F]) at the calibrated outside diameter
Trip Response Time	1 ms at trip rating, 24 ms optional
Minimum Reset (Operating) Current	3 A continuous, 1.5 A optional
Typical Reset Time	25 seconds at 10 A and above
Reset Type	Standard: Reset is triggered by current restoration for main phase sensor only. Optional: Three-phase reset automatically resets when current is restored in each phase of a three-phase set.
Maximum Fault Current	25 kA for 10 cycles at 60 Hz
Mounting Diameter Ranges	Standard: 0.75" to 2.10" (19 mm to 53 mm) Optional large core: 1.8" to 2.5" (46 mm to 64 mm)
Submersibility	15 ft (4.6 m)
Housing	UV-stabilized polycarbonate
Transformer Core	Vinyl-coated silicon steel
Temperature Range	−40° to +85°C (−40° to +185°F)
Auxiliary Contact Rating	Nominal switching capacity (resistive load): 0.8 A at 30 Vdc Contact rating (resistive load): 45 W Switching voltage: 165 Vdc maximum Switching current: 0.8 A maximum Insulation resistance: 50 MΩ minimum



Making Electric Power Safer, More Reliable, and More Economical
+1.509.332.1890 | info@selinc.com | selinc.com