

SEL-9322

15 Vdc Power Supply



Flexible and reliable power supply for low-voltage devices

- Provides +15 Vdc nominal output voltage for SEL security gateway, Real-Time Automation Controller (RTAC), and radio products.
- Support for ac or dc at two voltage input ranges allows the power supply to be used in a variety of applications for powering non-SEL devices.
- Mounts easily to any flat surface or DIN rail mount for flexible installation.
- Meets IEEE and IEC standards for electronic equipment deployed in electric power substations.



Overview

The SEL-9322 15 Vdc Power Supply is an ac-to-dc or dc-to-dc converter designed for harsh physical and electrical environments, including those found in electric utility substations. The SEL-9322 provides a nominal 15 Vdc at up to 1 A to power communications or instrumentation devices. The low-voltage output can be derived from higher-voltage dc battery sources or from higher-voltage ac sources. The range of options covers electric, gas, and water utility applications as well as telecommunications, industrial plant, and remote telemetry battery backup applications.

Applications

SEL Radio Power Supply

Power the SEL-3031 Serial Radio Transceiver and the SEL-3060 Ethernet Radio to support electric utility distribution automation, distributed generation, SCADA, and faster protection applications.

SEL-3505 Power Supply

Power SEL-3505 RTACs to support remote-site automation.

SEL-3622 Power Supply

Power the SEL-3622 Security Gateway to secure equipment at remote sites.

Industrial Equipment Power Supply

Provide power to equipment in unconditioned industrial locations. The SEL-9322 performs in harsh environments and meets strict quality standards.

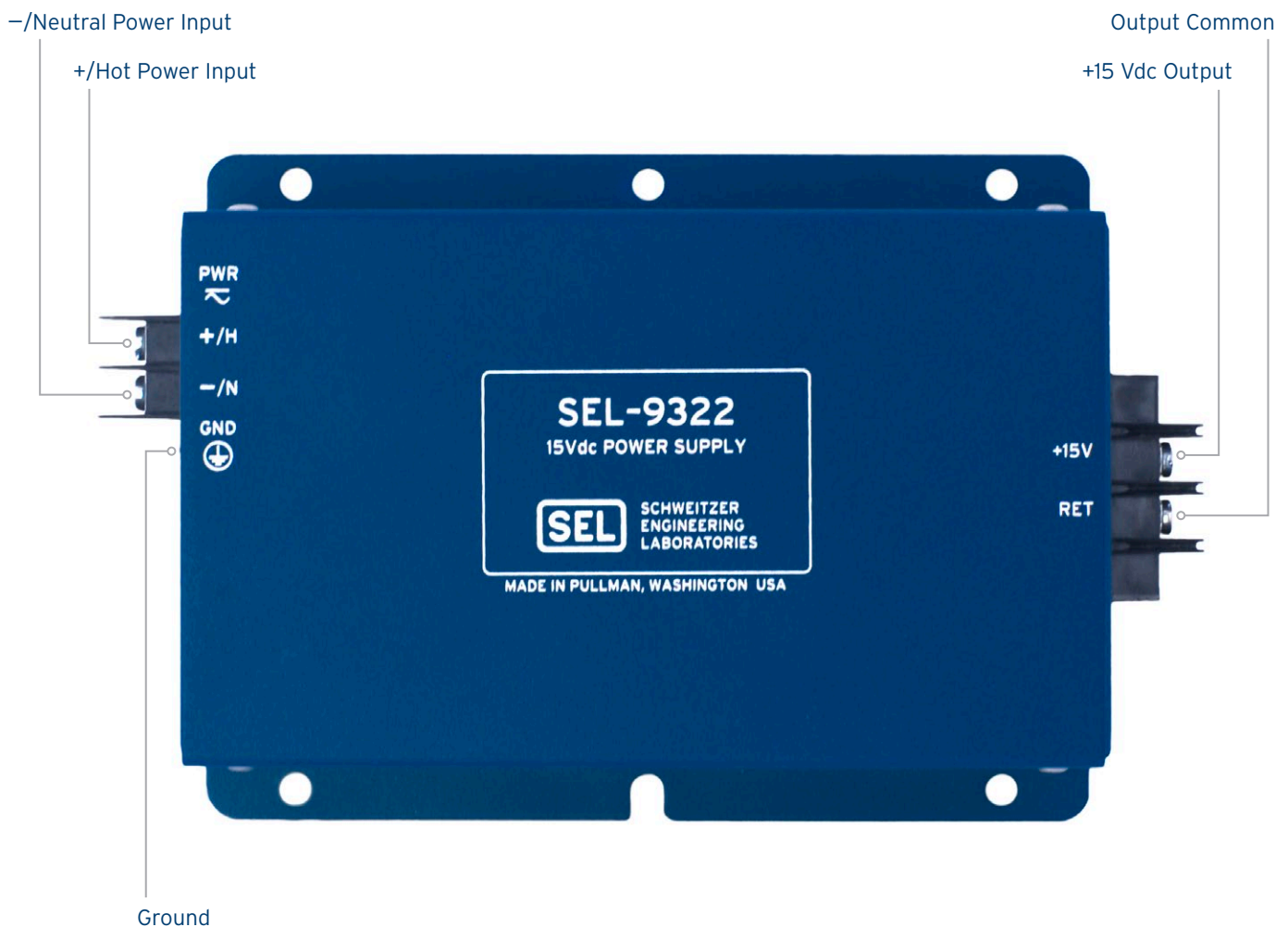

Type Tests

These type tests assume that the maximum length of the output cable is 3 m (10 ft).

Electrostatic Discharge Immunity	IEC 60255-26:2013
	IEC 61000-4-2:2008
	IEEE C37.90.3:2001
Fast Transient/Burst Immunity	IEC 60255-26:2013
	IEC 61000-4-4:2012
Radiated Radio Frequency Immunity	IEC 60255-26:2013
	IEC 61000-4-6:2006 + A1:2007 + A2:2010
	IEEE C37.90.2:2004
Conducted Radio Frequency Immunity	IEC 60255-26:2013
	IEC 61000-4-6:2008
Electromagnetic Emissions	IEC 60255-26:2013
	CISPR 11:2009 + A1:2010
	CISPR 22:2008
	Canada ICES-001 (A)/NMB-001 (A)
	47 CFR Part 15.107 and 109 Severity Level: Class A
Surge Immunity	IEC 60255-26:2013, Clause 7.2.7, Zone B
	IEC 61000-4-5:2005
Surge Withstand	IEC 61000-4-18:2006 + A1:2010
	IEEE C37.90.1:2012
Dielectric Strength	IEC 60255-27:2013
	IEEE C37.90:2005
Impulse	IEC 60255-27:2013
	IEEE C37.90:2005
Cold	IEC 60068-2-1:2007
Dry Heat	IEC 60068-2-2:2007
Damp Heat, Cyclic	IEC 60068-2-30:2005

Mounting and Physical Dimensions

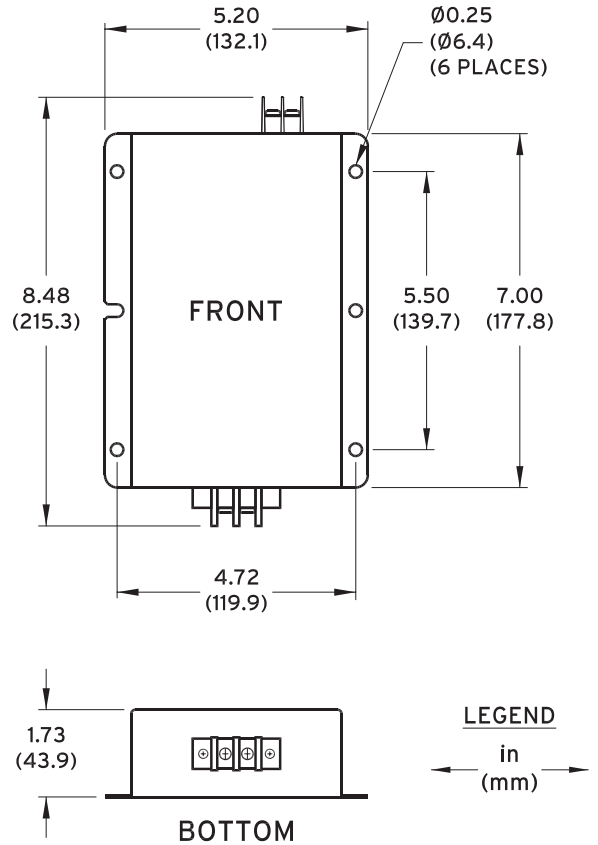

Specifications

General

Output +15 Vdc; 14.25–15.75 V, up to 1.0 A; 20 W

Connections

Tightening Torque: 1.01 Nm (9 in-lb)

Wire Size: 12–24 AWG

Wire Type: Copper, 60°/75°C, solid or stranded

Input

48–125 Vdc or 120 Vac

Operating range: 38–140 Vdc, 85–140 Vac (50/60 Hz)

125–250 Vdc or 120–240 Vac

Operating range: 85–300 Vdc, 85–264 Vac (50/60 Hz)

Burden: <40 W

Connections

Tightening Torque: 1.01 Nm (9 in-lb)

Wire Size: 12–18 AWG

Wire Type: Copper, 60°/75°C, solid or stranded with ring terminals

Environmental

Operating Temperature

–40° to +85°C (–40° to +185°F)

Maximum continuous ambient temperature per UL 508: +40°C

Humidity

5 to 95% noncondensing

Maximum Altitude

2000 m (6562 ft)

Atmospheric Pressure

80–110 kPa

Compliance

CE Mark

RCM Mark

UKCA Mark

47 CFR 15B, Class A

Note: This equipment has been tested and found to comply with the limits for a Class A digital device, pursuant to Part 15 of the FCC Rules. These limits are designed to provide reasonable protection against harmful interference when the equipment is operated in a commercial environment. This equipment generates, uses, and can radiate radio frequency energy and, if not installed and used in accordance with the instruction manual, may cause harmful interference to radio communications. Operation of this equipment in a residential area may be likely to cause harmful interference in which case the user will be required to correct the interference at his own expense. Any changes or modifications not expressly approved by the manufacturer can void the user's authority to operate the equipment.

Operating Environment

Pollution Degree 2

Overvoltage Category II

Certifications

ISO: Product is designed and manufactured to an ISO 9001:2008 certified quality program.

UL Listed: NMTR per UL 508



Making Electric Power Safer, More Reliable, and More Economical
+1.509.332.1890 | info@selinc.com | selinc.com

© 2023 by Schweitzer Engineering Laboratories, Inc.
PF00240 • 20231219

