

SEL-487V

Capacitor Bank Protection, Automation,
and Control System



One relay for all your capacitor bank needs

- Protect grounded and ungrounded, single- and double-wye capacitor bank configurations.
- Locate defective capacitor units faster, reducing maintenance effort and downtime.
- Keep electrical parameters within set ranges, even without external devices.
- Easily calculate relay settings with software tools.
- Improve system testing and post-fault analysis with comprehensive monitoring, metering, and event recording capabilities.



Overview

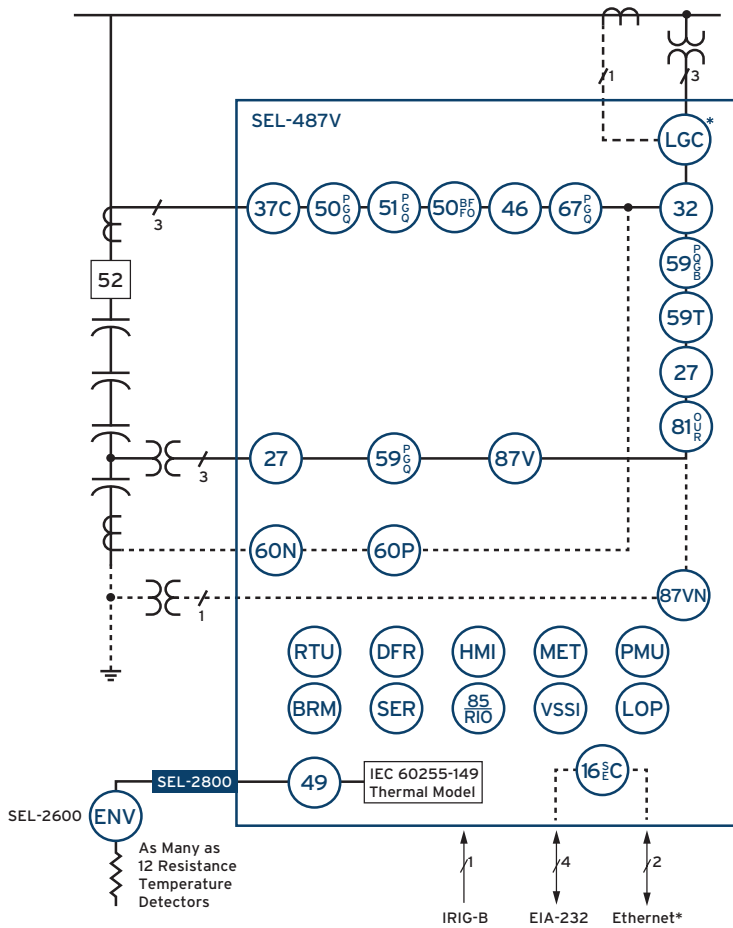

ANSI Numbers/Acronyms and Functions

27	Undervoltage
32	Real and Reactive Power
37C	Undercurrent
46	Current Unbalance
49	Programmable Thermal Control and Logic
50BF	Breaker Failure Overcurrent
50FO	Flashover Overcurrent
50 (P,G,Q)	Overcurrent (Phase, Ground, Negative Sequence)
51	Time Overcurrent (Selectable)
59 (P,Q,B)	Overvoltage (Phase, Negative Sequence, Bank)
60N	Neutral Current Unbalance
60P	Phase Current Unbalance
67 (P,G,Q)	Directional Overcurrent (Phase, Ground, Negative Sequence)
81 (O,U,R)	Frequency (Over, Under, Rate)
85 RIO	SEL MIRRORING BITS® Communications
87V	Phase Voltage Differential
87VN	Neutral Voltage Differential
DFR	Event Reports
HMI	Operator Interface
LGC	Capacitor Bank Control*
LOP	Loss of Potential
MET	High-Accuracy Metering
PMU	Synchrophasors
RTU	Remote Terminal Unit
SER	Sequential Events Recorder

Additional Functions

BRM	Breaker Wear Monitor
LDP	Load Data Profiling*

¹Copper or fiber-optic

*Optional feature

Key Features

Simple, Comprehensive Capacitor Protection

Phase and neutral voltage differential elements and phase and neutral current unbalance elements provide reliable protection for grounded and ungrounded, single- and double-wye configurations. You can simplify relay settings using the application-based Capacitor Bank Assistant in ACSELEATOR QuickSet® SEL-5030 Software to quickly calculate bank protection element thresholds.

Rapid Fault Locating

Faulted phase and section identification logic reduces the time needed to identify faulted capacitor units. The fault-locating logic provides discrete indications for the phase and section of the capacitor bank that has the faulted capacitor units.

Advanced Control

Obtain full control of your capacitor banks without the time and wiring to install an additional device. You can select from voltage, power factor, VAR, or time-of-day/day-of-week control schemes for up to three capacitor banks. Instability (hunting) detection helps prevent equipment damage by raising alarms or blocking control operations. Three independent sets of trip logic are available for staged-bank applications. With the SEL-487V-1, you can use the universal sequencer to automatically sequence the insertion and removal of up to three capacitor banks.

Advanced Protection Functions

Protect capacitors against abnormal system conditions using current, voltage, and frequency elements. Inverse-time overvoltage elements are provided that meet the IEC 60871-1:2005 standard for maximum allowable overvoltage for capacitor banks in service. For additional protection and monitoring, the relay has built-in thermal elements (conforming to IEC 60255-149), Total Harmonic Distortion measurement, and harmonic metering through the 15th harmonic.

Flexible Inputs and Indication

The SEL-487V supports multiple digital I/O boards and analog inputs from an SEL-2600 RTD Module and has user-definable pushbuttons and indicator LEDs.

Breaker Monitoring and Protection

A full-function breaker failure system provides logic to detect a reignition or restrike (also called flashover) across any one of the three breaker poles.

Automation and Communication

Improve station integration and reduce costs with the free-form SELogic® editor in the SEL-487V. Custom SELogic control equations offer the flexibility to tailor the relay to your particular application. Program control equations for each control output based on data received from primary equipment or other devices, and use communications protocols to send status and control signals to other protection system devices using serial or Ethernet protocols. Integrate the SEL-487V into a larger system using communication protocols, including the following:

- MIRRORRED BITS communications
- DNP3 LAN/WAN
- IEC 61850 Edition 2
- Parallel Redundancy Protocol (PRP)
- Simple Network Time Protocol (SNTP)

Product Overview

EIA-232 front serial port is convenient for system setup and local access.

Easy-to-use keypad aids simple navigation.

24 programmable target LEDs with user-configurable labels alert operators in the substation to faulted phases, the relay's status, and element operation.

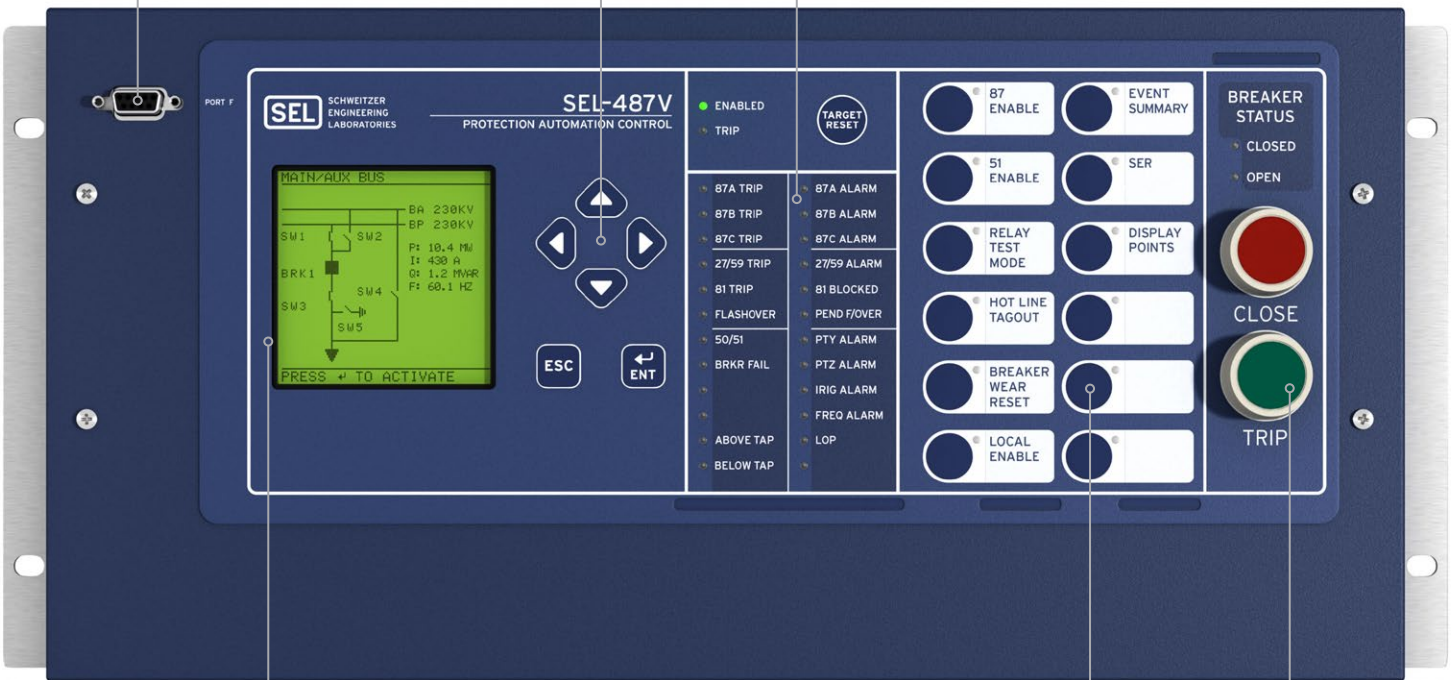

LCD allows you to control and view the status of disconnects and breakers.

Programmable operator pushbuttons with user-configurable labels allow front-panel customization.

Optional trip/close pushbuttons and indicating LEDs allow breaker control independent of the relay.

Use one front and three rear EIA-232 ports for MIRRORRED BITS communications, DNP3, SCADA, and engineering access.

Choose from a vertical or horizontal, panel-mount or rack-mount chassis and different size options.

Communications protocols include FTP, Telnet, synchrophasors, DNP3 LAN/WAN, the Parallel Redundancy Protocol (PRP), and IEC 61850 Edition 2.

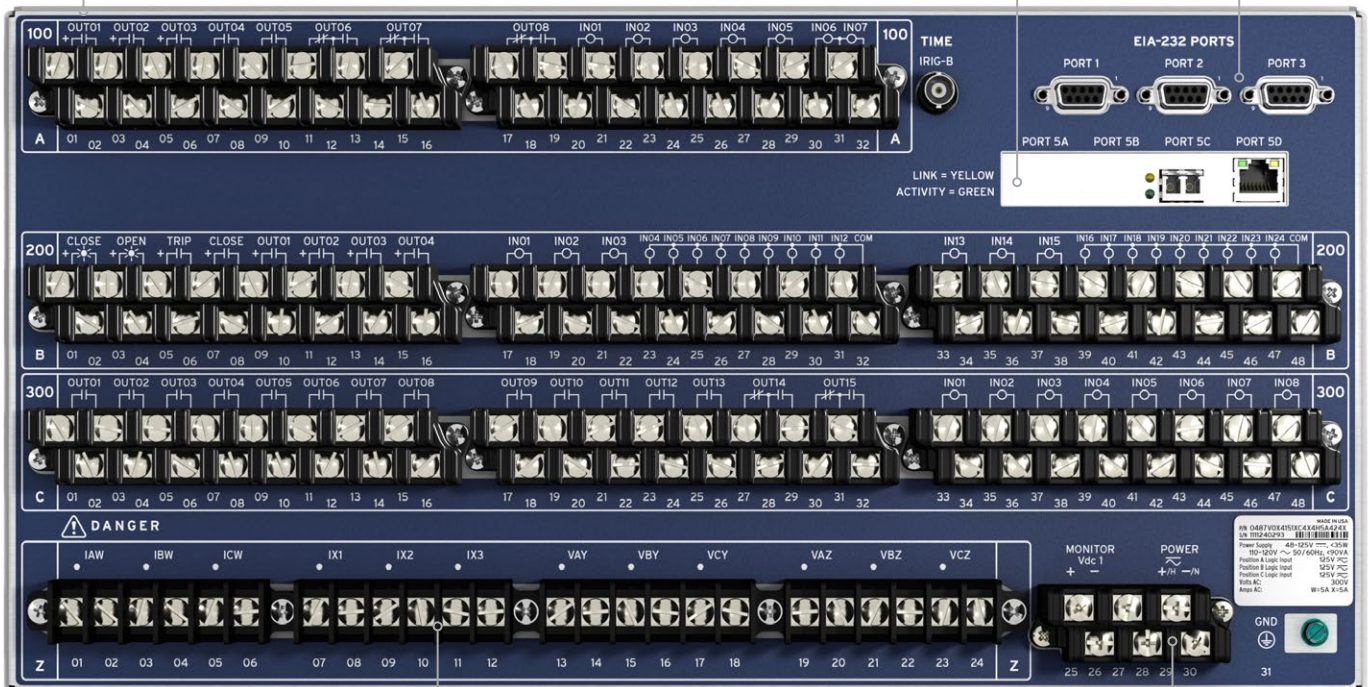

Six current and six voltage channels support applications for grounded and ungrounded, single- and double-wye capacitor configurations.

Power supply options include 48–125 Vdc or 110–120 Vac; or 125–250 Vdc or 110–240 Vac.

Applications

Differential Protection

Voltage differential elements detect variations in capacitor bank impedance due to the loss of individual capacitor elements, a single capacitor unit, or a group of units.

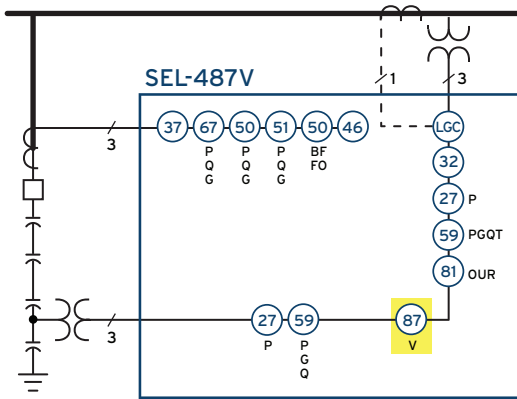

Voltage Differential

Grounded single-bank capacitor with tapped PT.

Unbalance Protection

Detect faulted capacitor elements with phase and neutral current unbalance elements. Phase current or neutral current unbalance elements protect grounded and ungrounded multiple-wye banks.

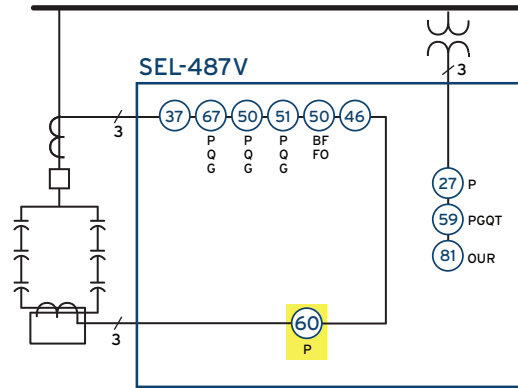

Phase Current Unbalance

Grounded or ungrounded double-wye capacitor bank with phase CT.

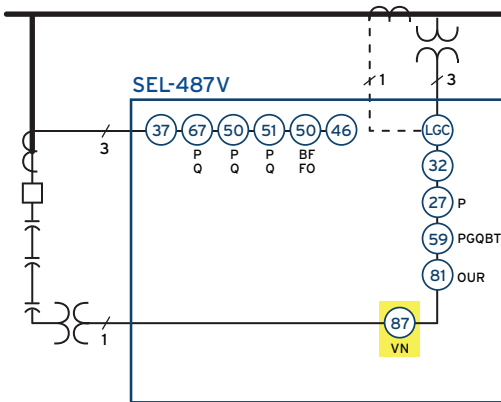

Neutral Voltage Differential

Ungrounded single- or double-wye bank capacitor with neutral PT.

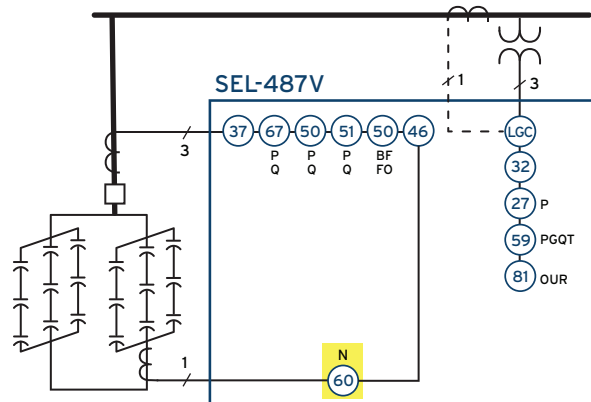

Neutral Current Unbalance

Ungrounded double-wye capacitor bank with neutral CT.

Capacitor Switching and Control

Obtain full control of your capacitor banks without installing an additional device. Automatic and manual, local and remote deadband control functions let you maintain system voltage, VAR, or power factor (PF) levels. Instability detection logic prevents equipment damage by raising alarms or blocking control operations. The time-of-day/day-of-week control feature synchronizes capacitor bank insertion with peak VAR demand periods. Use the universal sequencer to automatically sequence up to three capacitor banks based on accumulated operating time.

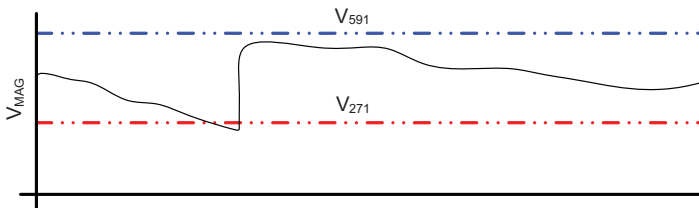

Voltage control deadband characteristics.

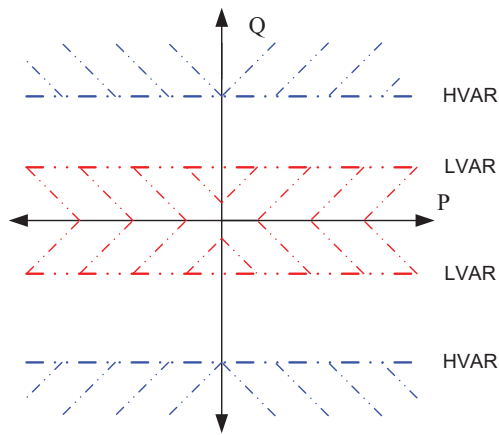

VAR deadband control characteristics.

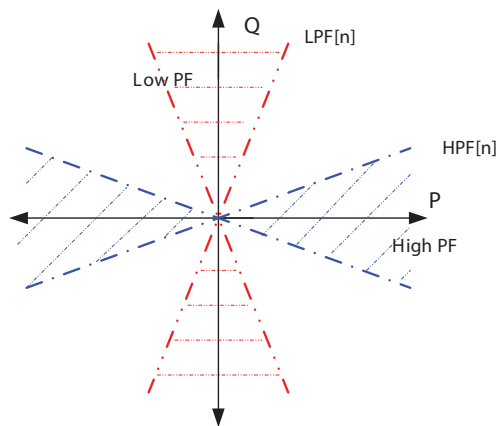

PF deadband control characteristics.

Advanced Fault Detection

Reduce the time needed to identify faulted capacitor bank units with the faulted phase and section identification logic in the SEL-487V. This logic provides discrete indications for the phase and section of the bank that has the faulted capacitor units. For voltage differential applications, the phase angle of the differential voltage determines the faulted phase and the sign of the differential voltage determines whether the fault is above or below the tap. For current unbalance applications, the phase angle of the unbalanced current determines the phase and section of the bank where the fault is. The fault location information is included as part of the event report.

Real-Time Control

Make informed system operational decisions based on actual real-time phasor measurements from across your power system. With built-in time correlation, the SEL-487V combines local and remote messages to make control decisions. Control functions based on phase angles, currents, and voltages provide flexibility for a variety of applications.

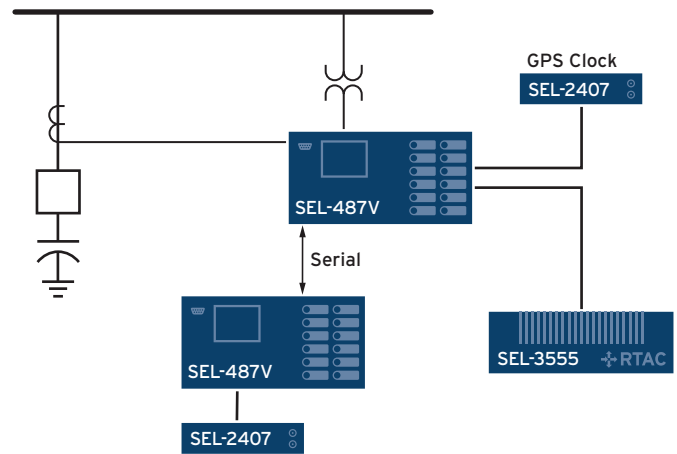

You can use real-time control in the SEL-487V for simple applications and can use the SEL-3555 Real-Time Automation Controller (RTAC) for more complex applications.

Breaker Failure Detection

The SEL-487V includes a full-function breaker failure system. High-speed, open-phase detection logic allows you to set the pickup current below the minimum load for high sensitivity without sacrificing high-speed dropout. Even in cases with subsidence current in the secondary of the CT caused by trapped flux, the SEL-487V achieves high-speed detection of the circuit breaker opening. This feature is essential if breaker failure is initiated on all circuit breaker trips. A reset of less than one cycle reduces coordination times, improving stability.

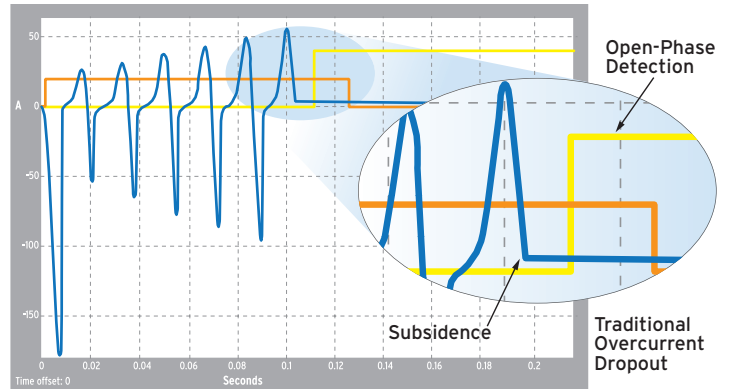

Breaker Flashover Detection

The SEL-487V uses per-phase fundamental and rms current measurement to quickly detect breaker restriking and flashover across any one of the three breaker poles after the breaker is opened. Because capacitor switching can place significant stress on a breaker, monitoring is crucial. SEL's enhanced event analysis recording has a resolution from 1 to 8 kHz to capture restriking and other breaker problems.

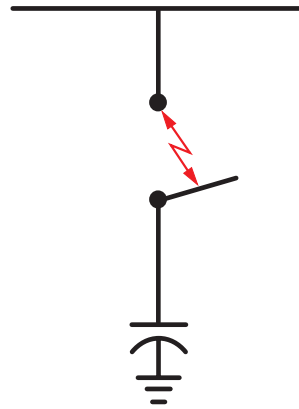

Accessibility and Communications

MIRRORED BITS Communications

This field-proven technology provides simple and powerful bidirectional digital communications between devices. MIRRORED BITS communications can transmit and receive information between relays for better coordination.

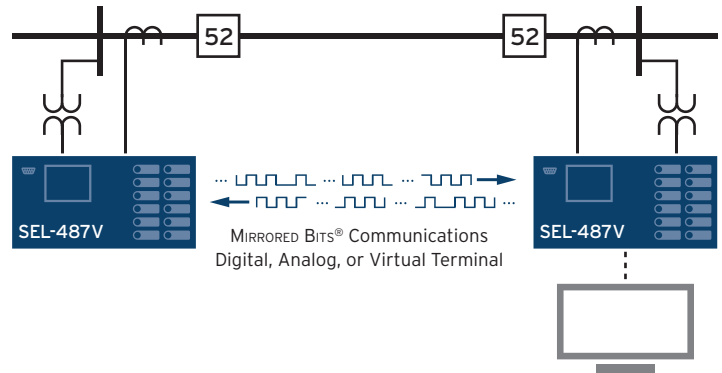

Ethernet-Based Communications

An Ethernet card option provides two copper, two fiber-optic, or mixed ports (one of each) for failover redundancy. Simplify the Ethernet network topology and reduce external equipment with dual Ethernet ports that offer a switched mode for looped Ethernet networks. Available Ethernet communications protocols include FTP, Telnet, DNP3 LAN/WAN, IEC 61850 edition 2, IEEE C37.118 synchrophasors, and PRP.

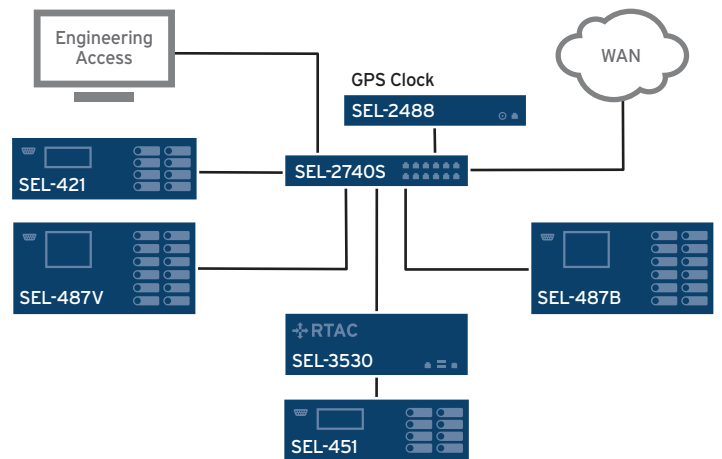

Built-In Web Server

Use the optional Ethernet card to access basic SEL-487V information on a standard Ethernet network with the built-in web server. View the relay status, Sequential Events Recorder (SER) data, metering information, and settings. For increased security, obtaining web server access requires a relay password, and the information is limited to a read-only view.

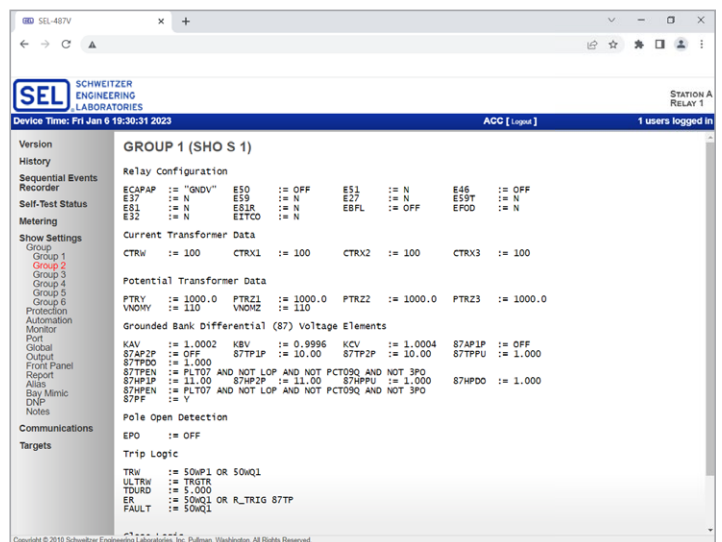

Setting and Commissioning Software

Capacitor Bank Assistant

Use the Capacitor Bank Assistant, included in QuickSet, to analyze the impact of failed capacitor bank components. The Capacitor Bank Assistant applies the standard analysis techniques provided by IEEE C37.99, *IEEE Guide for the Protection of Shunt Capacitor Banks*. Input nameplate ratings and other capacitor bank parameters to calculate relevant voltages or neutral current after failure, and use these data to develop relay settings.

Capacitor Bank Assistant
Capacitor Bank Protection Application

Construction: Fuseless
Protection Method: Voltage Differential (ECAPAP+GNDV)

Capacitor Bank Configuration

Series Groups (S)	1-200	8
Parallel Units per Phase (P)	1-50	1
Parallel Units per Phase in Left Wye (Fa)	1-50	1
Parallel Elements per Group (N)	1-50	3
Number of Series Element Groups in Capacitor Unit (Su)	1-50	10
Series Groups within Tap Portion (St)	1-100	1
Parallel Units in Affected String (P)	1-50	1
Parallel Strings per Phase (Sp)	1-20	3
Parallel Strings per Phase in Left Wye (Sl)	1-20	3
System Voltage (kV line-line)	4.00-750.00	245.00
Rated Cap Bank Voltage (kV line-line)	1.00-800.00	230.00
Rated Cap Bank Power (KVAR)	1.00-999999.00	47664.00
LV Tap Cap Voltage (V)	100.00-10000.00	825.00
LV Tap Cap Power (VAR)	100.00-999999.00	334000.00
Current Imbalance CT Ratio	1.00-5000.00	1.00
PT Ratio Bus	1.00-7000.00	2000.00
PT Ratio Tap/Neutral	1.00-7000.00	3.20

Print Calculate

Tapped Voltage Display Table

Number of Faulty Units/Elements/Fuses	Bus Primary Voltage (kV-n)	Tap Primary Voltage (V) Fault Above Tap	Tap Primary Voltage (V) Fault Below Tap	Bus Secondary Voltage (V)
0	141.45	259.24	N/A	70.73
1	141.45	260.33	N/A	70.73
2	141.45	261.45	N/A	70.73
3	141.45	262.60	N/A	70.73

Graphical Logic Editor (GLE)

The GLE in QuickSet lets you view SELogic control equations graphically and document your settings files for validation and commissioning. You can convert existing SELogic control equations to easy-to-read diagrams and save the diagrams.

The GLE helps reduce design errors, time, and expenses when commissioning relays. The convenient diagram navigation tool, drag-and-drop interface, function block diagrams, and automatic layout function help you design new SELogic control equations. A full element palette makes it easy to manage control diagrams.

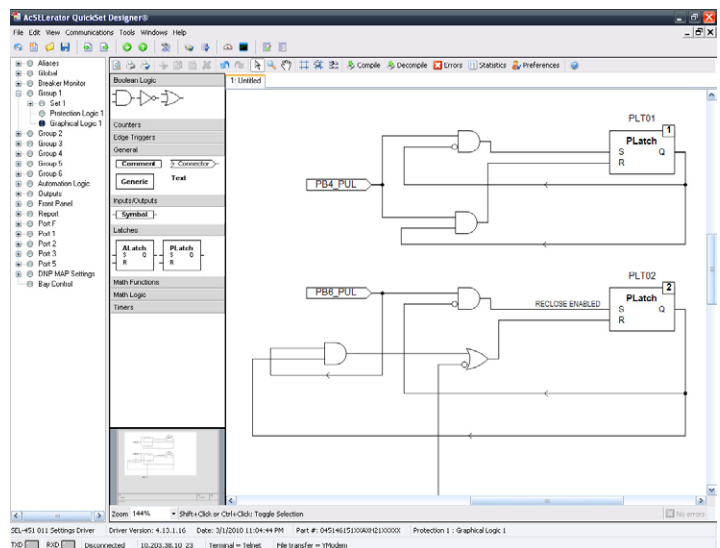

Specifications

General Specifications

AC Current Inputs (6 total)	5 A nominal 1 A nominal
AC Voltage Inputs (6 total)	300 V _{L-N} continuous, 600 Vac for 10 seconds
Serial	1 front-panel and 3 rear-panel EIA-232 serial ports 300–57,600 bps
Ethernet (optional)	Choose from the following port options: Two 10/100BASE-T twisted-pair network ports Two 100BASE-FX fiber-optic network ports One 10/100BASE-T twisted-pair network port and one 100BASE-FX fiber-optic network port
Communications Protocols	SEL (Fast Meter, Fast Operate, and Fast SER), DNP3, FTP, IRIG-B, Telnet, SNTP, IEC 61850 edition 2, PRP, MIRRORRED BITS communications, and IEEE C37.118-2005 (synchrophasors).
Synchrophasors	IEEE C37.118 standard Up to 60 messages per second 5 independent, configurable data streams
Processing	AC voltage and current inputs: 8,000 samples per second Primary protection and control processing: 8 times per power system cycle
Power Supply	48–125 Vdc or 110–120 Vac 125–250 Vdc or 110–240 Vac
Operating Temperature	–40° to +85°C (–40° to +185°F)

SEL SCHWEITZER ENGINEERING LABORATORIES

Making Electric Power Safer, More Reliable, and More Economical
+1.509.332.1890 | info@selinc.com | selinc.com

© 2023 by Schweitzer Engineering Laboratories, Inc.
PF00207 • 20230123

