



Applying the SEL-487B as a Station Breaker Failure Relay

Christina Kusch

INTRODUCTION

Failure of a circuit breaker to operate is one of the most critical events that can occur in a substation because it has far-reaching effects on the power system. In addition to optimized bus differential protection, SEL offers complete breaker failure protection in the SEL-487B Bus Differential and Breaker Failure Relay. This versatile bus differential relay with breaker failure protection saves time and money and provides peace of mind that circuit breakers are fully protected.

PROBLEM

Breaker failure protection can be difficult to implement. Many relays can only protect one breaker at a time, thereby increasing the number of relays needed and requiring additional time and money to install hardware and wiring. External breaker failure schemes can result in a delay in initiating breaker failure protection, causing unnecessary damage. Also, the burden of many breaker failure relays adds additional current transformer (CT) requirements.

SEL SOLUTION

The SEL-487B has 21 current inputs, making it capable of protecting up to 7 three-phase circuit breakers. Its high-speed, open-circuit detection provides shorter coordinating times, resulting in reduced tripping time and improved system stability. The low burden of the SEL-487B does not add to CT requirements.

SEL-487B complete breaker failure protection uses open-phase detection logic to reduce breaker failure coordination times. There are two options available: schemes equipped with external breaker failure relays and schemes using internal breaker failure protection. Schemes equipped with external breaker failure relays send a bus trip (output from the breaker failure relay on the terminal panel) command to the SEL-487B and require only the zone selection and output contacts to operate the appropriate breakers. Schemes using SEL-487B internal breaker failure protection send a breaker failure initiate (normally a trip output) command to the SEL-487B to operate the appropriate breakers. Figure 1 shows a comparison of open-phase detection to traditional overcurrent methods. The SEL-487B is also capable of retrip for each terminal.

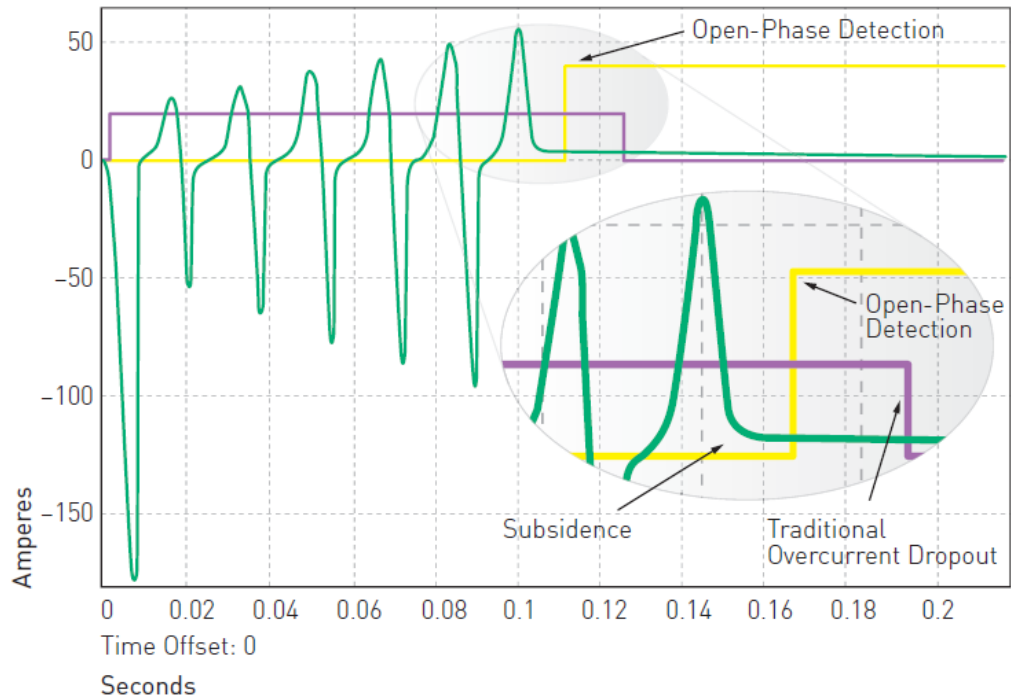

Figure 1 High-Speed, Open-Phase Detection Logic Detects Open-Pole Conditions in Fewer Than 0.75 Cycles to Reduce Failure Coordination Times

The relay also has dynamic zone selection logic that assigns the appropriate input current values to the corresponding differential elements for calculating per-zone operation and restraint quantities and determining the breakers to trip for differential and breaker failure protection operation (see the example in Figure 2). The SEL-487B dynamically reassigns input currents to the appropriate differential and breaker failure zones when the station configuration changes.

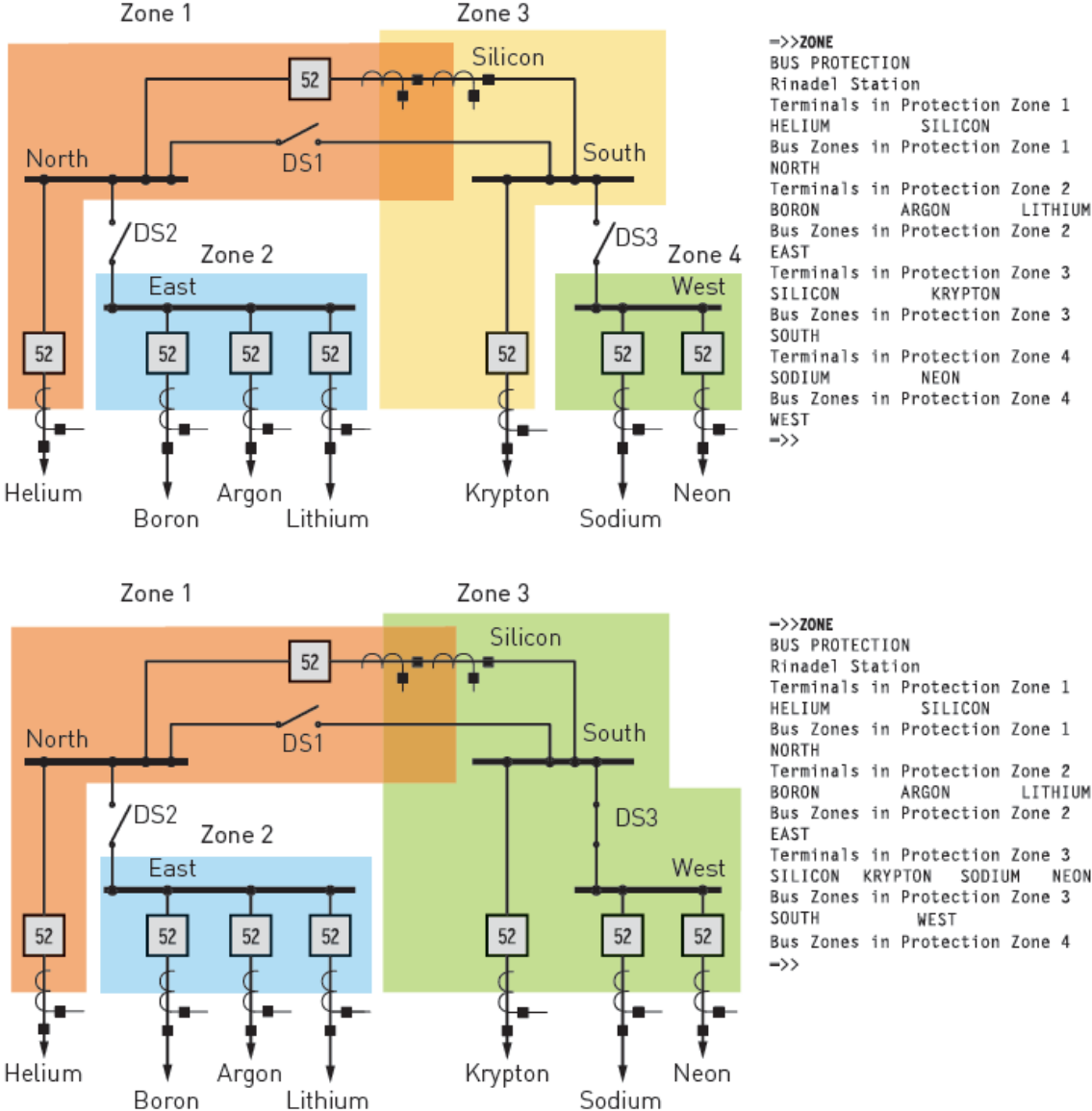

Figure 2 Dynamic Zone Configuration

Because the relay has already been wired and set up for bus protection, breaker failure protection is available with no additional labor, saving time and money and providing complete protection.

© 2009, 2014 by Schweitzer Engineering Laboratories, Inc.
All rights reserved.



SCHWEITZER ENGINEERING LABORATORIES, INC.

2350 NE Hopkins Court • Pullman, WA 99163-5603 USA
Tel: +1.509.332.1890 • Fax: +1.509.332.7990
www.selinc.com • info@selinc.com