

SEL-2431

Voltage Regulator Control

Field Reference Guide

20260216

SEL SCHWEITZER ENGINEERING LABORATORIES



* P M 2 4 3 1 - 0 2 *

© 2007–2026 by Schweitzer Engineering Laboratories, Inc.

Content subject to change without notice. Unless otherwise agreed in writing, all SEL product sales are subject to SEL's terms and conditions located here: <https://selinc.com/company/termsandconditions/>.

PM2431-02

Table of Contents

List of Tables	iii
List of Figures	v
Preface	vii
Section 1: Overview	
Retrofit Kits	1.1
SEL-2431 Enclosure	1.2
Hardware	1.3
Section 2: Installation	
Synchronize the Tap Position	2.1
Mounting the Control in Retrofit Applications	2.1
Mounting the Voltage Regulator Control Enclosure	2.3
Ground the Control Chassis	2.5
Connect a Second Voltage or Voltage Questions	2.5
Connect the Wiring Harness From the Voltage Regulator Interface to the SEL-2431	2.5
Jumpers and Clock Battery	2.15
Section 3: Front-Panel Interface	
Overview	3.1
Control Power, Control Configuration, and Motor Control	3.2
USB Flash Drive Support	3.5
External Source Terminals, Fuses, and Voltmeter Test Terminals	3.8
Display and Navigation Pushbuttons	3.9
Operator Control Pushbuttons	3.13
Operation and Indication LEDs	3.14
Setting Voltage Regulator Tap Position	3.16
Voltage Regulator Bypassing	3.16
Section 4: Basic Settings	
Overview	4.1
View/Change Settings Using the Front Panel	4.2
Settings Explanations	4.2
Basic Global Settings	4.3
Basic Group Settings	4.6
Determine Lead and Lag Units in Open-Delta or Closed-Delta Voltage Regulator Installations	4.15
Section 5: Testing and Troubleshooting	
Overview	5.1
Testing Philosophy	5.1
Testing Methods and Tools	5.4
Self-Tests	5.6
Voltage Regulator Control Troubleshooting	5.8
Technical Support	5.11
Appendix A: Field Reference Guide Versions	
Appendix B: Voltage Connections, Internal Voltage Regulator Wiring, and Voltage Polarity Reversal	
Understand Voltage Sources and Settings Correspondence Before Making Connections	B.1
Make Preparatory Voltage Connections to the Voltage Regulator Interface; Internal Voltage Regulator Wiring	B.3
Voltage and Current Polarity Reversal	B.10

Appendix C: Internal SEL-2431 Wiring and Extra I/O Connections

Internal WiringC.1
 120 VAC WHETTING Output and Inputs IN101 and IN102 C.2
 Output Contacts OUT101 Through OUT104.....C.3
 Optoisolated Inputs IN201 Through IN204 (+12 Vdc).....C.4
 12 Vdc (6 W) Output.....C.4

Appendix D: Circuit Grounding vs. Chassis Grounding

Definitive Circuit Grounding for GE Voltage Regulators..... D.1
 Circuit Grounding for Other Voltage Regulators D.1

Appendix E: Voltage Base and Ratio Correction Transformer

Voltage Base.....E.1
 Ratio Correction Transformer (RCT).....E.2

Appendix F: Voltage Regulator Control Enclosure Standard Features and Optional Accessories

Standard Features F.1
 Optional Accessories F.2

Appendix G: Voltage Regulator Control Enclosure Drawings

List of Tables

Table 1.1	SEL-2431 Retrofit Kits	1.1
Table 1.2	SEL-2431 Mounting Hardware Kits	1.1
Table 2.1	Password Jumper Operation.....	2.15
Table 3.1	USB Main Menu Choices	3.6
Table 3.2	Report Files Stored During Read Reports and Automatic Backup.....	3.7
Table 3.3	Fuses.....	3.9
Table 3.4	Navigation Pushbutton Functions	3.12
Table 4.1	Use of Enable Settings	4.2
Table 5.1	Status Report Results	5.7
Table 5.2	Troubleshooting Procedures.....	5.9
Table A.1	Field Reference Guide Revision History	A.1
Table F.1	RCT Connection for Effective Output Correction Ratio	F.5
Table F.2	RCT Connection for 120 Vac Output Voltage.....	F.5
Table F.3	Eaton/Cooper 12-Conductor Wiring	F.6

This page intentionally left blank

List of Figures

Figure 1.1	SEL-2431 Enclosure	1.2
Figure 1.2	Front-Panel Features	1.3
Figure 1.3	Rear-Panel Features.....	1.4
Figure 1.4	SEL-2431 Dimensions	1.5
Figure 1.5	SEL-2431 Enclosure Dimensions	1.6
Figure 2.1	Attach Hinges and Latch to the SEL-2431 for Mounting in a Siemens or Toshiba CR-3 Voltage Regulator Enclosure	2.1
Figure 2.2	Attach Hinges and Latch to the SEL-2431 for Mounting in a Howard Voltage Regulator Enclosure	2.2
Figure 2.3	Attach Hinges and Latch to the SEL-2431 for Mounting in a Cooper Voltage Regulator Enclosure	2.2
Figure 2.4	Attach Hinges and Latch to the SEL-2431 for Mounting in a GE Voltage Regulator Enclosure	2.3
Figure 2.5	Four-Wire Wye System Installation Example	2.4
Figure 2.6	Siemens (Polarized Disconnect Switch [PDS]) or Howard (Connector Terminal Strip [CTS]) Control Wiring Harness	2.6
Figure 2.7	Cooper Traditional (18-/10-Position Fanning Strip) Control Wiring Harness	2.7
Figure 2.8	Cooper Dead-Front (20-Position Connector) Control Wiring Harness	2.8
Figure 2.9	GE Traditional (Fork-Terminal Connections) Control Wiring Harness	2.9
Figure 2.10	GE Power Disconnect (24-Position Connector) Control Wiring Harness	2.10
Figure 2.11	Generic Control Wiring Harness (Siemens, Howard, or GE).....	2.10
Figure 2.12	Generic Control Wiring Harness (Cooper or McGraw-Edison)	2.10
Figure 2.13	Toshiba Manufactured Control Wiring Harness for Toshiba CR-3.....	2.11
Figure 2.14	Romagnole Manufactured Control Wiring Harness for Romagnole SVR.....	2.11
Figure 2.15	ITB Manufactured Control Wiring Harness for ITB RAV-2.....	2.12
Figure 2.16	SEL-2431 Enclosure Wiring Cross-Reference to Common Voltage Regulator Interfaces .	2.14
Figure 2.17	Location of Password Jumper JMP1-A and Clock Battery on Rear of the Circuit Board	2.15
Figure 3.1	Different Sections of the SEL-2431 Front Panel	3.2
Figure 3.2	Control Power, Control Configuration, and Motor Control Section of the SEL-2431 Front Panel (Pushbutton Version)	3.3
Figure 3.3	Control Power, Control Configuration, and Motor Control Section of the SEL-2431 Front Panel (Toggle Switch Version).....	3.3
Figure 3.4	Functions/Schemes Enabled by the Different REMOTE, LOCAL, AUTO, and MANUAL Modes.....	3.4
Figure 3.5	External Source Terminals, Fuses, and Voltmeter Test Terminals Section of the SEL-2431 Front Panel	3.8
Figure 3.6	Display and Navigation Pushbuttons	3.10
Figure 3.7	Password Prompt Display	3.11
Figure 3.8	Operator Control Pushbuttons.....	3.13
Figure 3.9	Operation and Indication LEDs.....	3.14
Figure 5.1	Main Menu	5.5
Figure 5.2	Targets Menu and Targets Display	5.5
Figure B.1	General Design of a Siemens or Howard Type A (Straight) Voltage Regulator	B.2
Figure B.2	General Design of a GE or Cooper Type A (Straight) Voltage Regulator	B.2
Figure B.3	General Design of a Siemens, Howard, Cooper, Toshiba CR-3, ITB RAV-2, or Romagnole SVR Type B (Inverted) Voltage Regulator.....	B.3
Figure B.4	General Design of a GE Type B (Inverted) Voltage Regulator	B.3
Figure B.5	Siemens or Howard Regulator/Control Wiring Harness Interface.....	B.4
Figure B.6	Cooper Regulator/Control Wiring Harness Interface.....	B.5
Figure B.7	GE Traditional Regulator/Control Wiring Harness Interface	B.6
Figure B.8	GE Power Disconnect Regulator/Control Wiring Harness Interface.....	B.6
Figure B.9	Toshiba CR-3 Regulator/Control Wiring Harness Interface.....	B.7
Figure B.10	ITB RAV-2 Regulator/Control Wiring Harness Interface	B.7

Figure B.11	Romagnole SVR Regulator/Control Wiring Harness Interface	B.7
Figure B.12	Adding a Second Voltage to a Siemens or Howard Type B (Inverted) Regulator/Control Wiring Harness Interface (Siemens Shown, Howard Similar)	B.9
Figure B.13	Voltage Details for Siemens or Howard Type A (Straight) Regulator/Control Wiring Harness Interface	B.10
Figure C.1	SEL-2431 Internal Wiring—Voltage and Current Inputs	C.1
Figure C.2	SEL-2431 Internal Wiring—Raise/Lower Outputs and Other Inputs/Outputs	C.2
Figure C.3	SEL-2431 Internal Wiring—Other Inputs/Outputs on Connectors J2 and J3	C.3
Figure E.1	Convert SEL-2431 Voltage Sensing to Customer Voltage Base	E.1
Figure E.2	RCT in SEL-2431 Voltage Sensing Path	E.2
Figure F.1	Surge Suppression Accessory	F.1
Figure F.2	RCT Wiring Diagram	F.4
Figure F.3	RCT Schematic	F.5
Figure F.4	Eaton/Cooper 12-Conductor	F.6
Figure G.1	Voltage Regulator Control Enclosure Schematic Diagram	G.1
Figure G.2	Voltage Regulator Control Enclosure’s RCT Point-to-Point Wiring Diagram	G.2
Figure G.3	Voltage Regulator Control Enclosure Point-to-Point Wiring Diagram	G.3
Figure G.4	Voltage Regulator Control Enclosure Point-to-Point Wiring Diagram (Continued)	G.4

Preface

About the SEL-2431 Field Reference Guide and the SEL-2431 Instruction Manual

NOTE: These documents are not a substitute for the documentation that comes with a voltage regulator, including the safety warnings and procedures.

Field Reference Guide

The *SEL-2431 Voltage Regulator Control Field Reference Guide* covers the installation and set-up of the SEL-2431 Voltage Regulator Control for general applications through the front-panel HMI.

The *SEL-2431 Voltage Regulator Control Instruction Manual* covers the operation of the SEL-2431 for advanced applications through the serial port communications interface, front-panel HMI, or PC software interface.

Store the included SEL-2431 menu card in the control box. This card contains the HMI menu tree.

The *SEL-2431 Voltage Regulator Control Field Reference Guide* is aimed at technicians who have some familiarity with voltage regulators and any existing voltage regulator controls, and are planning on relatively straightforward control settings. The guide contains topics not covered in the *SEL-2431 Voltage Regulator Control Instruction Manual*, including the following:

- Compatible voltage regulator types in *Section 1: Overview*
- Installation in *Section 2: Installation*
- Voltage regulator overview in *Section 2: Installation*
- Voltage regulator control wiring harness connections in *Section 2: Installation*
- Fusing in *Section 2: Installation*
- Internal wiring/functions in *Section 2: Installation*
- Basic front-panel operation in *Section 3: Front-Panel Interface*
- Jumpers and clock battery in *Section 2: Installation*
- Basic settings in *Section 4: Basic Settings*

Instruction Manual

The *SEL-2431 Voltage Regulator Control Instruction Manual* is intended for use with specialized applications such as voltage reduction, and offers more information on control operation, communications, and SELOGIC® programming.

The manual contains topics that are not in the *SEL-2431 Voltage Regulator Control Field Reference Guide*, including the following:

- Specifications in *Section 1: Introduction and Specifications*
- PC software in *Section 2: PC Software*
- Description of control algorithms in *Section 3: Control Algorithms*

- Description of control operating modes in *Section 4: Control Operating Modes*
- Tap operation details in *Section 5: Tap Operations*
- Overcurrent elements, SELOGIC control equations, and multiple setting groups in *Section 6: Logic Functions*
- Description of metering and tap counters in *Section 7: Metering and Monitoring*
- Signal profile recorder in *Section 7: Metering and Monitoring*
- Full control settings, including all factory-default settings, in *Section 8: Settings*
- Serial and Ethernet communications including commands and DNP3, in *Section 9: Communications, Appendix C: SEL Communications Processors, and Appendix D: DNP3 Communications*
- Advanced front-panel operations, including programmable buttons, display points and local control functions, in *Section 10: Front-Panel Operations*
- Event reports and Sequential Events Recorder (SER) in *Section 11: Analyzing Events*
- Firmware versions in *Appendix A: Firmware and Instruction Manual Versions*
- Firmware upgrade instructions in *Appendix B: Firmware Upgrade Instructions*

Safety Information

Dangers, Warnings, and Cautions

This manual uses three kinds of hazard statements, defined as follows:

DANGER

Indicates an imminently hazardous situation that, if not avoided, **will** result in death or serious injury.

WARNING





Indicates a potentially hazardous situation that, if not avoided, **could** result in death or serious injury.





CAUTION

Indicates a potentially hazardous situation that, if not avoided, **may** result in minor or moderate injury or equipment damage.

Safety Symbols

The following symbols are often marked on SEL products.

	 CAUTION Refer to accompanying documents.	 ATTENTION Se reporter à la documentation.
	Earth (ground)	Terre

	Protective earth (ground)	Terre de protection
	Direct current	Courant continu
	Alternating current	Courant alternatif
	Both direct and alternating current	Courant continu et alternatif
	Instruction manual	Manuel d'instructions

Safety Marks

The following statements apply to this device.

Other Safety Marks

<p>⚠ WARNING Have only qualified personnel service this equipment. If you are not qualified to service this equipment, you can injure yourself or others, or cause equipment damage.</p>	<p>⚠ AVERTISSEMENT Seules des personnes qualifiées peuvent travailler sur cet appareil. Si vous n'êtes pas qualifiés pour ce travail, vous pourriez vous blesser avec d'autres personnes ou endommager l'équipement.</p>
<p>⚠ WARNING Carefully follow the voltage regulator bypassing procedures in the voltage regulator instruction manual, if bypassing is necessary.</p>	<p>⚠ AVERTISSEMENT Suivez attentivement les procédures de contournement du régulateur de tension indiquées dans le manuel du régulateur de tension si un contournement est nécessaire.</p>
<p>⚠ WARNING Ground the SEL-2431 Voltage Regulator Control chassis before making any other connections to the control.</p>	<p>⚠ AVERTISSEMENT Mettez à ta terre le châssis de la commande du régulateur de tension du SEL-2431 avant d'effectuer n'importe quel autre raccordement à la commande.</p>
<p>⚠ WARNING In the many connection procedures that follow, de-energize the involved circuits and follow other standard safety procedures in making the connections. Consult the voltage regulator instruction manual for more information.</p>	<p>⚠ AVERTISSEMENT Dans les nombreuses procédures de raccordement qui suivent, retirez l'alimentation des circuits concernés et suivez les instructions de sécurité standards en effectuant les raccordements. Consultez le manuel du régulateur de tension pour plus d'information.</p>
<p>⚠ CAUTION Connect only 120 Vac nominal to the SEL-2431 (rear-panel VOLTAGES connector and front-panel EXTERNAL SOURCE terminals—see Figure C.1).</p>	<p>⚠ ATTENTION Ne raccordez le SEL-2431 qu'à du 120 VCA nominal (VOLTAGES sur le connecteur du panneau arrière ou bornes "EXTERNAL SOURCES" sur panneau avant -voir Figure C.1).</p>
<p>⚠ CAUTION Equipment components are sensitive to electrostatic discharge (ESD). Undetectable permanent damage can result if you do not use proper ESD procedures. Ground yourself, your work surface, and this equipment before removing any cover from this equipment. If your facility is not equipped to work with these components, contact SEL about returning this device and related SEL equipment for service.</p>	<p>⚠ ATTENTION Les composants de cet équipement sont sensibles aux décharges électrostatiques (DES). Des dommages permanents non-décelables peuvent résulter de l'absence de précautions contre les DES. Raccordez-vous correctement à la terre, ainsi que la surface de travail et l'appareil avant d'en retirer un panneau. Si vous n'êtes pas équipés pour travailler avec ce type de composants, contactez SEL afin de retourner l'appareil pour un service en usine.</p>

General Information

Typographic Conventions

There are three ways to communicate with the SEL-2431:

- Using a command-line interface on a PC terminal emulation window
- Using the front-panel menus and pushbuttons
- Using ACSELERATOR QuickSet® SEL-5030 Software

The instructions in this manual indicate these options with specific font and formatting attributes. The following table lists these conventions.

Example	Description
STATUS	Commands typed at a command-line interface on a PC.
<Enter>	Single keystroke on a PC keyboard.
<Ctrl+D>	Multiple/combo combination keystroke on a PC keyboard.
Start > Settings	PC software dialog boxes and menu selections. The > character indicates submenus.
CLOSE	Voltage regulator control front-panel pushbuttons.
ENABLE	Voltage regulator control front- or rear-panel labels.
MAIN > METER	Voltage regulator control front-panel LCD menus and voltage regulator control responses visible on the PC screen. The > character indicates submenus.
SELOGIC control equations	SEL trademarks and registered trademarks contain the appropriate symbol on first reference in a section. In the <i>SEL-2431 Voltage Regulator Control Instruction Manual</i> , certain SEL trademarks appear in small caps. These include SELOGIC control equations and ACSELERATOR QuickSet SEL-5030 software program.
Modbus®	Registered trademarks of other companies include the registered trademark symbol with the first occurrence of the term in a section.

Examples

This instruction manual uses several example illustrations and instructions to explain how to effectively operate the SEL-2431. These examples are for demonstration purposes only; the firmware identification information or settings values included in these examples may not necessarily match those in the current version of your SEL-2431.

Section 1

Overview

Retrofit Kits

SEL-2431 Voltage Regulator Control retrofit kits are available for the supported regulator makes and models. The kits can be included as part of the SEL-2431 part number at the time a control is ordered or they can be ordered separately using the part numbers listed in *Table 1.1*.

NOTE: For Toshiba CR-3 or ITB RAV-2 wiring harness, contact the voltage regulator manufacturer.

Table 1.1 SEL-2431 Retrofit Kits

Retrofit Kit	Part Number
Siemens/Allis-Chalmers: 10-position Polarized Disconnect Switch (PDS) Interface ^a	9253002
Howard Industries: 10-position Connector Terminal Strip (CTS) Interface ^a	9253003
Cooper/McGraw-Edison: 18-/10-position Fanning Strip (Traditional Interface) ^a	9253004
Cooper: 20-position Connector (Dead-front Interface) ^a	9253005
Cooper: 20-Position Connector (Dead-front Interface) with Extended Harness ^a	9253008
GE: Fork-terminal Connections (Traditional Interface to Cabinet NN Terminals) ^a	9253006
GE: 24-position Connector (Power Disconnect Interface) ^a	9253007
Generic Fork Terminals for Cooper/McGraw-Edison ^b	9253055
Generic Fork Terminals for Siemens/Allis-Chalmers/Howard/GE/Romagnoles ^b	9253001

^a Includes mounting hardware (hinges and latch), and all necessary wiring harnesses (including PDS, CTS, Fanning Strip, or another applicable enclosure connector for mating with existing voltage regulator interfaces).

^b Does not include mounting hardware (hinges and latches). Includes wiring harness only. If mounting hardware is required, select the appropriate kit from Table 1.2.

Table 1.2 shows the mounting hardware kits available for the SEL-2431. These kits are orderable using the part numbers shown in *Table 1.2*.

NOTE: For ITB RAV-2 mounting hardware, contact voltage regulator manufacturer.

Table 1.2 SEL-2431 Mounting Hardware Kits

Mounting Hardware Kit	Part Number
Siemens/Allis-Chalmers Mounting Hardware Kit ^a	9253059
Howard Mounting Hardware Kit	9253060
Cooper/McGraw-Edison Mounting Hardware Kit	9253058
GE Mounting Hardware Kit	9253057

^a Use Siemens/Allis-Chalmers Mounting Hardware Kit (part number 9253059) to mount the SEL-2431 into a Toshiba CR-3 or Romagnole SVR voltage regulator.

SEL-2431 Enclosure

The SEL-2431 is offered with an optional weather-resistant, rugged, outdoor control enclosure (see *Figure 1.1*) for use with new and retrofit installations. The enclosure assembly is a complete unit that only requires the device to be mounted and properly wired from the enclosure's terminals to the supported voltage regulator's control wiring. *Section 2: Installation* describes the installation and wiring of the enclosure in more detail.

The SEL-2431 Enclosure is intended for use on single-phase distribution voltage regulators. It is a weather-resistant, rugged, outdoor control enclosure that protects the SEL-2431 from the environment and provides physical security. The enclosure is large enough to accommodate the SEL-2431, wiring harness, terminal block, voltage correction transformers, and wireless communications equipment. It can be mounted to the tank of a single-phase voltage regulator, pole mounted in a bank of three controls for midline installations, or mounted in a control house or other type of framework in distribution substations.

The enclosure comes with standard features, making it a robust and durable option for many applications. It is made of marine-grade aluminum painted ANSI 61 Gray. Its IP55 rating indicates its resistance against dust and water ingress. The easily removable door comes with threaded fasteners on the exterior to mount or transfer a voltage regulator nameplate and includes an interior document storage compartment. The door's closing method was designed with a pad-lockable, slotted-drive cam lock, and the cable entrances support security sleeves, adding a level of security to the enclosure. The bottom connection panel of the enclosure comes with an external ground lug that accepts #10 SOL-#4 STR ground wire. The enclosure comes with standard accessories, including a surge suppression device and a bracket for mounting a motor capacitor to make it motor capacitor ready.

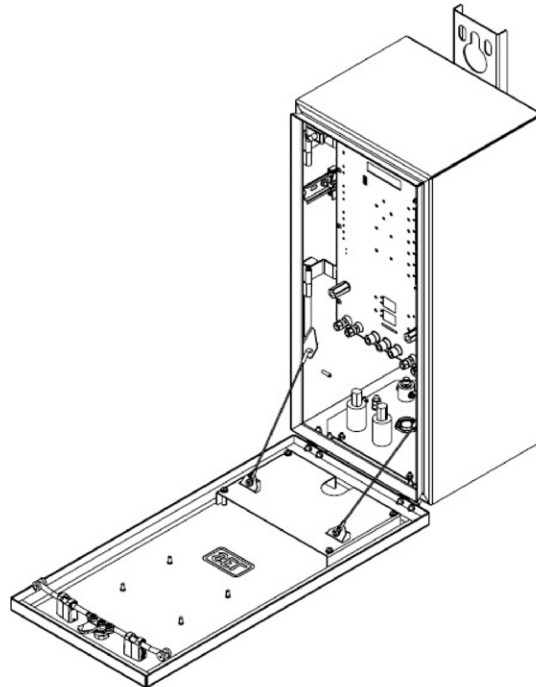

Figure 1.1 SEL-2431 Enclosure

Hardware

Front Panel

Figure 1.2 shows the front panel of the SEL-2431 Voltage Regulator Control. Functionality of the operator controls, status indication LEDs, and LCD navigation are described in more detail in Section 3: Front-Panel Interface.

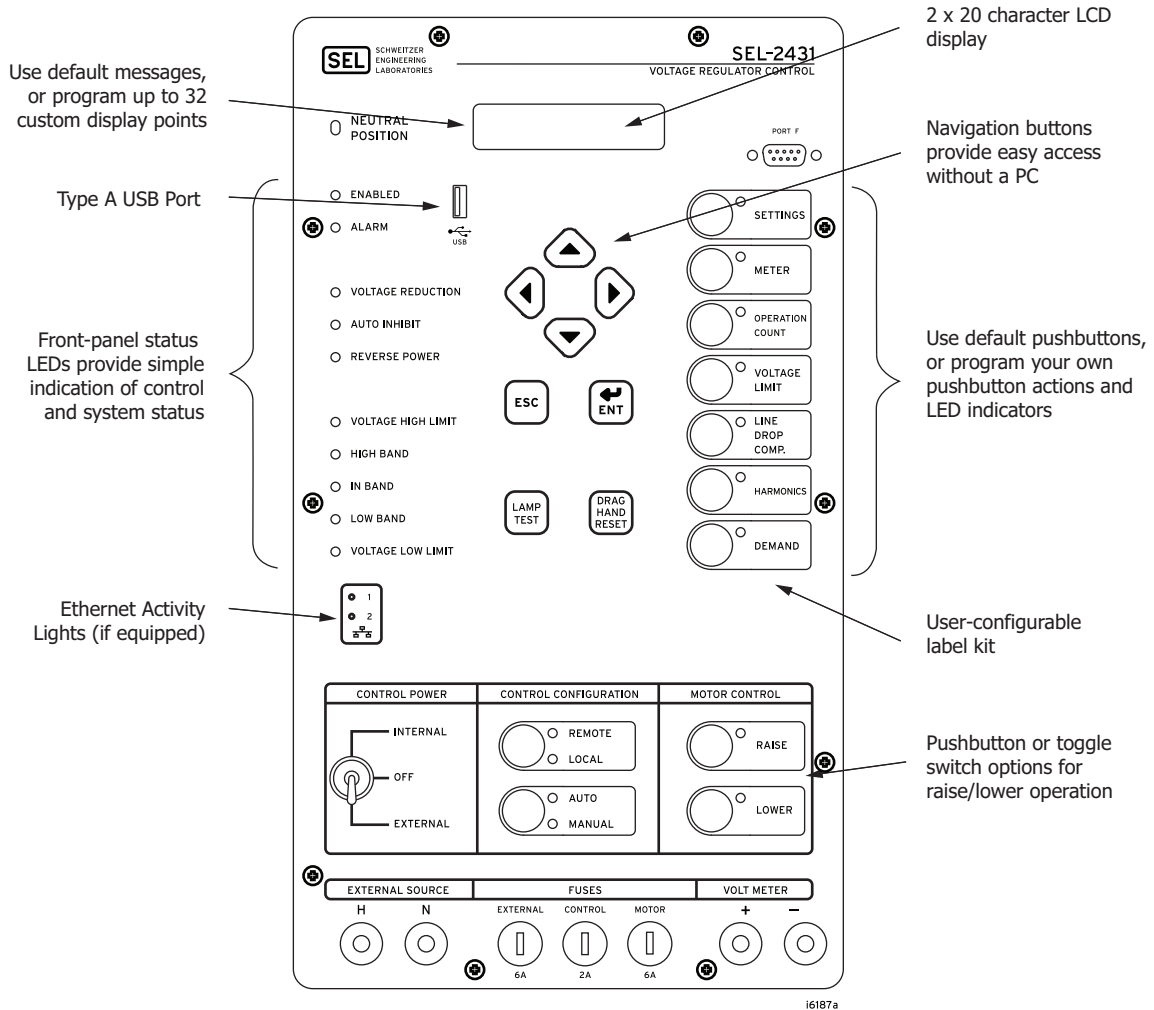

Figure 1.2 Front-Panel Features

Rear Panel

Figure 1.3 shows the rear panel of the SEL-2431 Voltage Regulator Control. Wiring interface details are described in detail in Section 2: Installation and Appendix C: Internal SEL-2431 Wiring and Extra I/O Connections. Communications interface details are located in Section 9: Communications in the SEL-2431 Voltage Regulator Control Instruction Manual.

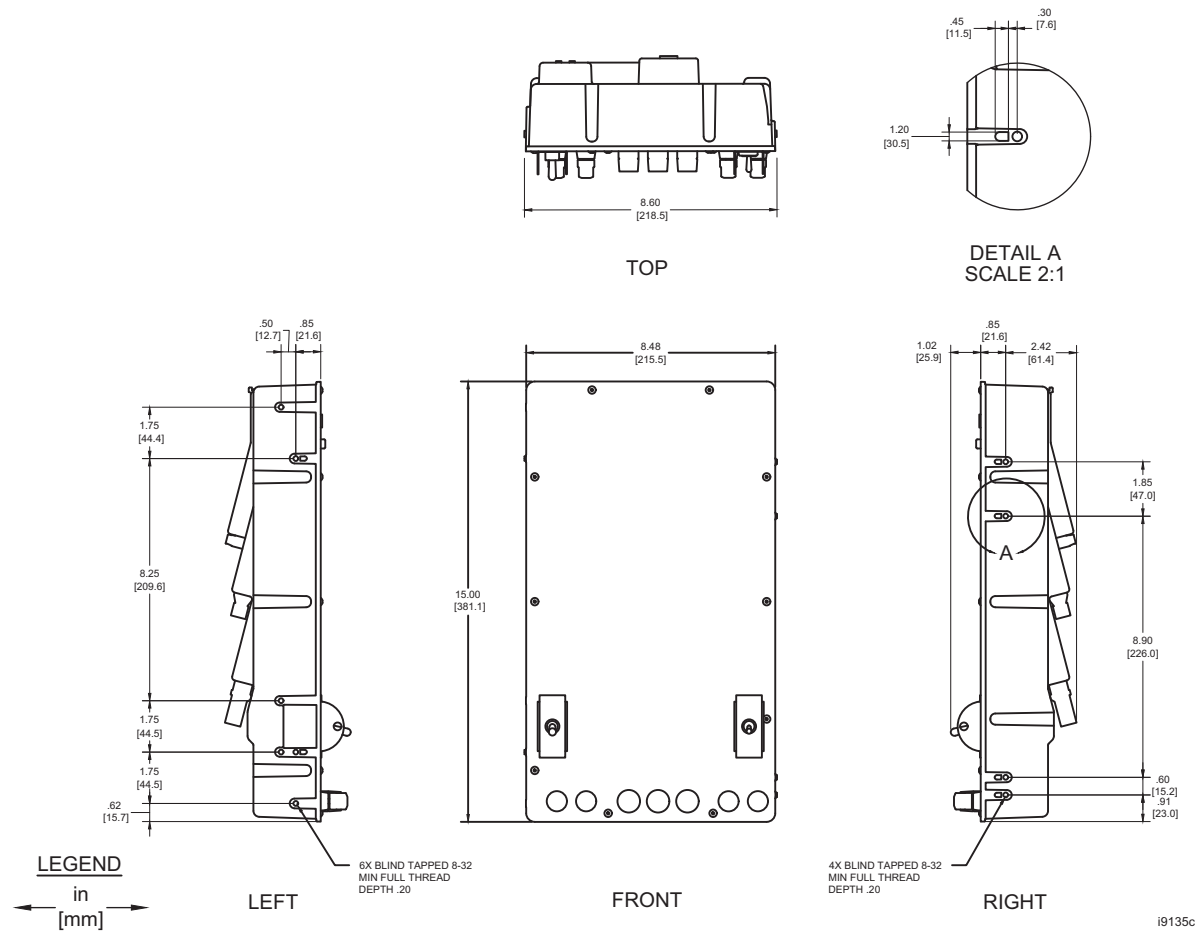
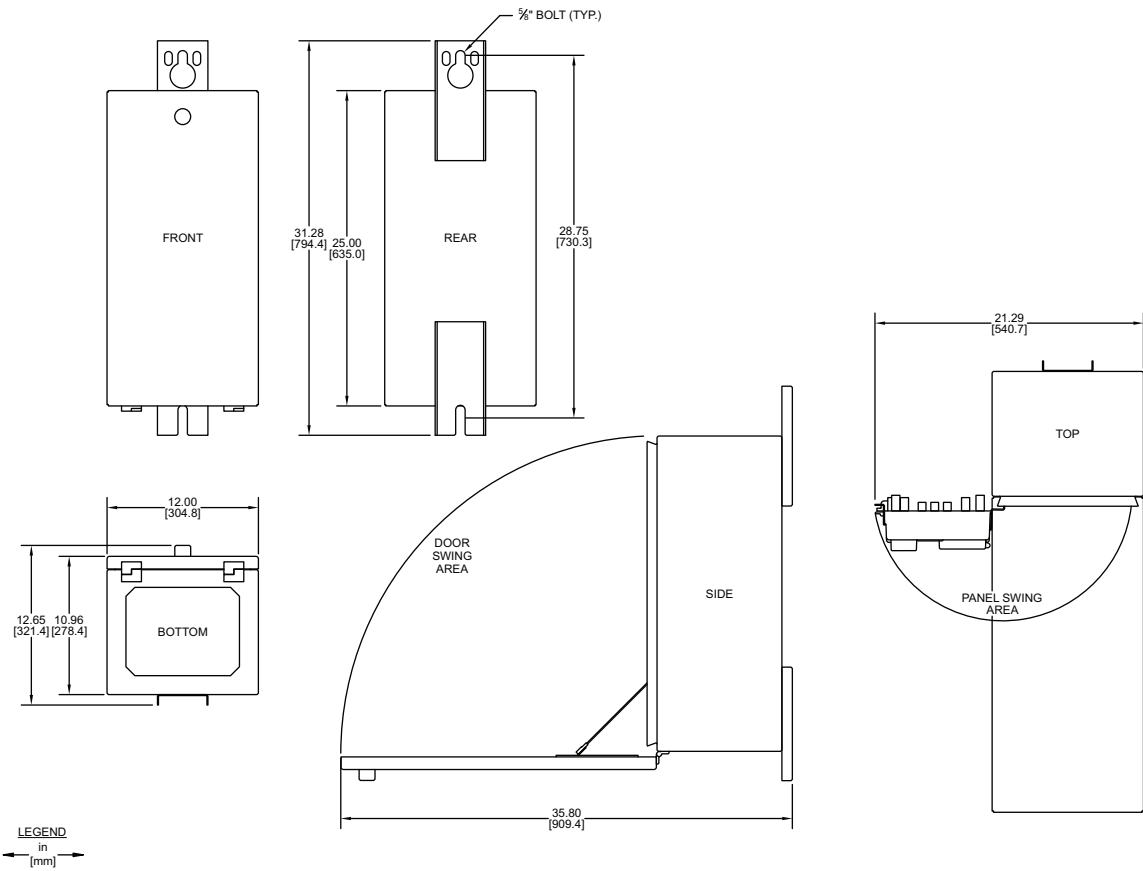

Figure 1.4 SEL-2431 Dimensions



i9429a

Figure 1.5 SEL-2431 Enclosure Dimensions

Section 2

Installation

Synchronize the Tap Position

When the SEL-2431 is first installed on a voltage regulator, the tap position counter in the SEL-2431 should be synchronized to match the tap position of the regulator. Use either of the following methods to synchronize the tap position:

- ▶ Tap through the neutral tap position. The assertion of the Neutral position switch will cause the SEL-2431 to set the Tap Position counter to 0.
- ▶ Manually set the tap position, either by using the front-panel interface, or by issuing a **TAP P x** command on the terminal (see the instruction manual for more information).

Mounting the Control in Retrofit Applications

Reference *Figure 2.1–Figure 2.4* to attach the appropriate hinges and latch to the SEL-2431.

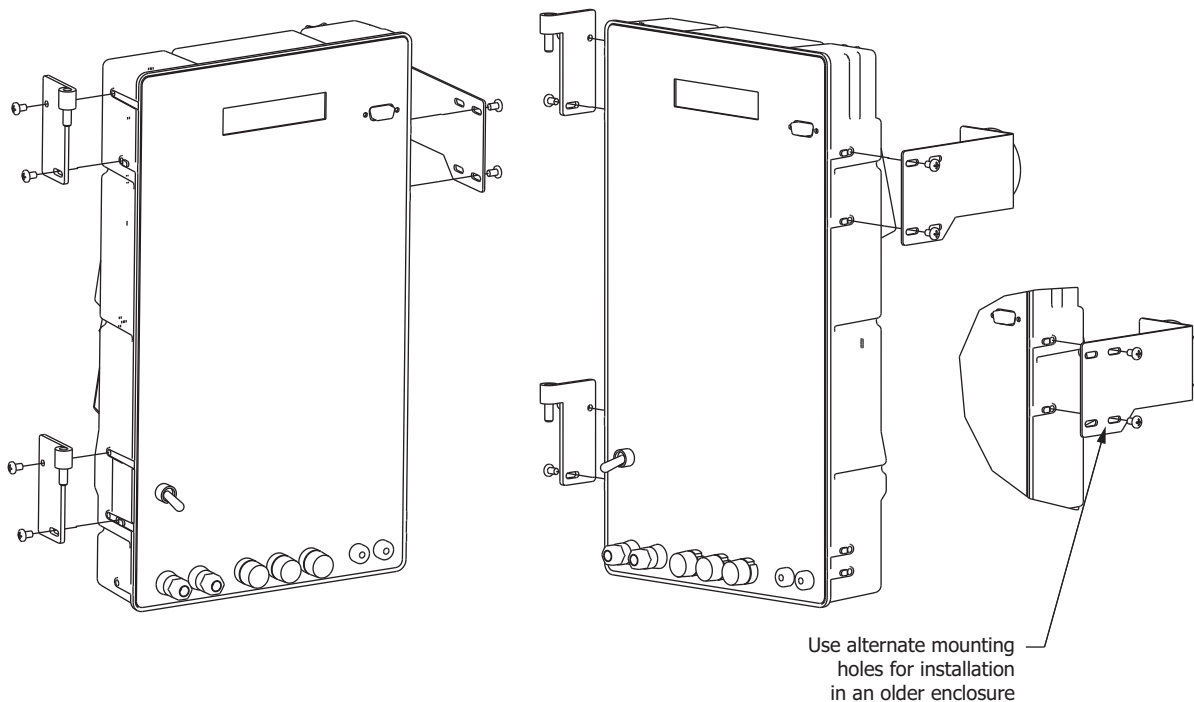

Figure 2.1 Attach Hinges and Latch to the SEL-2431 for Mounting in a Siemens or Toshiba CR-3 Voltage Regulator Enclosure

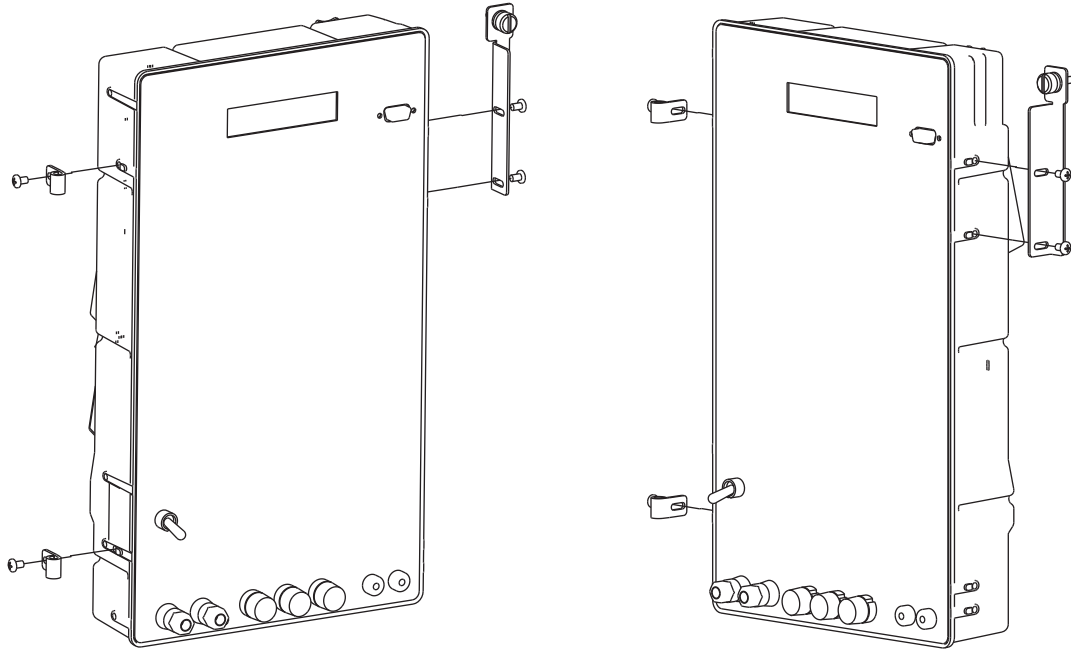

Figure 2.2 Attach Hinges and Latch to the SEL-2431 for Mounting in a Howard Voltage Regulator Enclosure

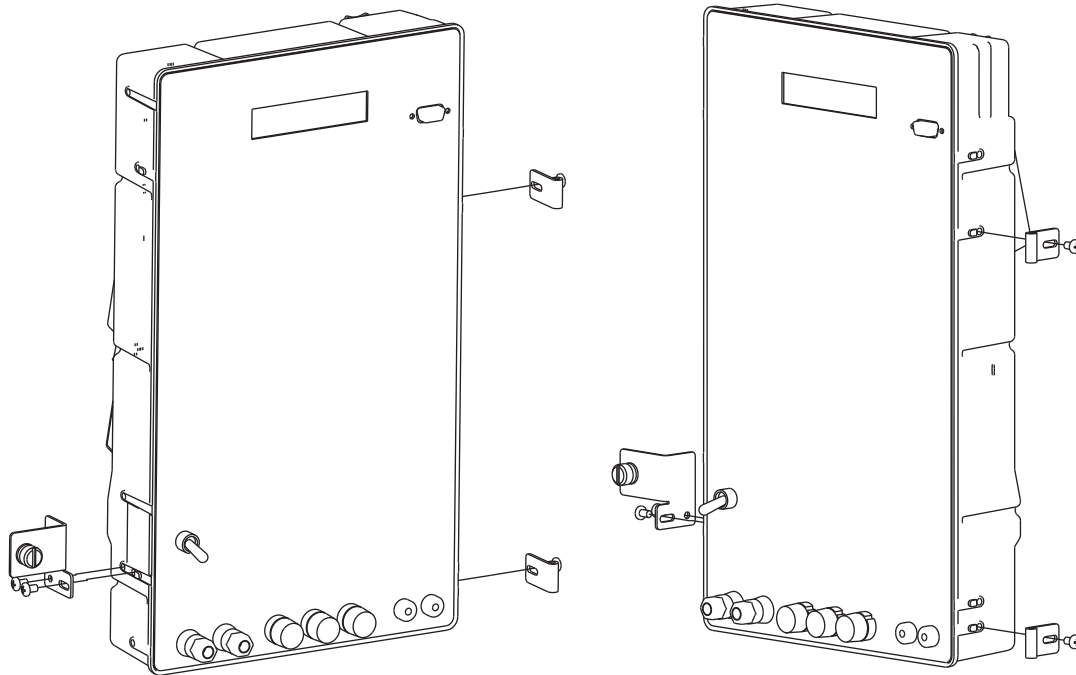

Figure 2.3 Attach Hinges and Latch to the SEL-2431 for Mounting in a Cooper Voltage Regulator Enclosure

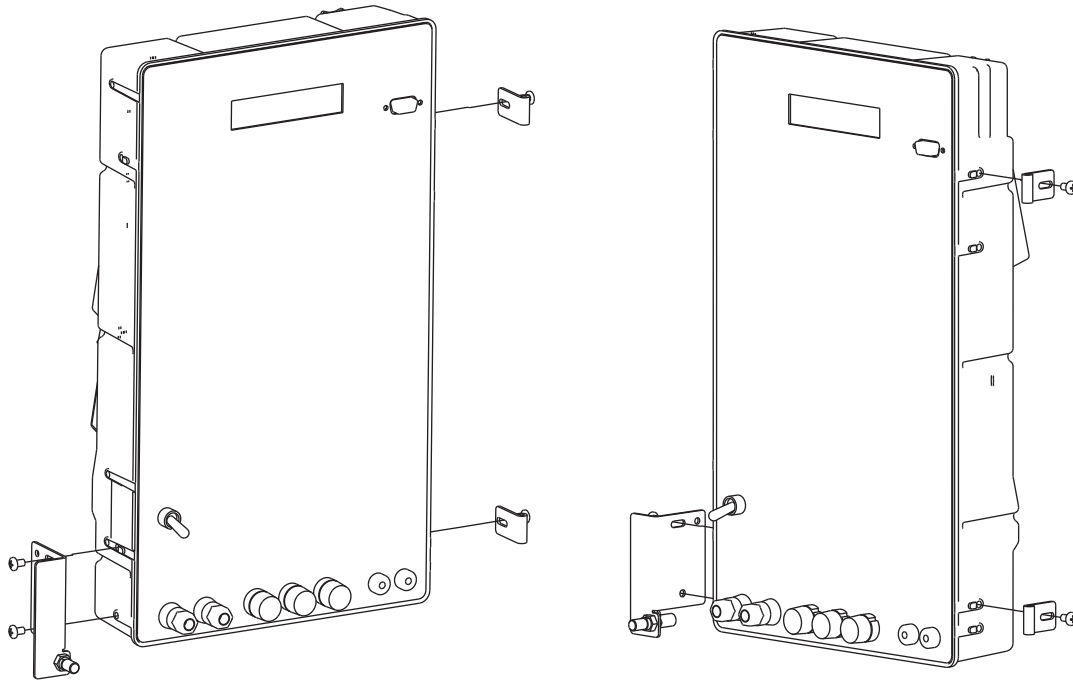

Figure 2.4 Attach Hinges and Latch to the SEL-2431 for Mounting in a GE Voltage Regulator Enclosure

Mounting the Voltage Regulator Control Enclosure

WARNING

Have only qualified personnel service this equipment. If you are not qualified to service this equipment, you can injure yourself or others, or cause equipment damage.

WARNING

Take proper precautions to prevent personal injury or equipment damage when lifting and mounting the SEL-2431. Make sure doors are latched closed. Secure lifting attachments to the lifting holes. Lift slowly.

The following instructions describe how to install the SEL-2431 Enclosure and provide a visual representation of a standard installation.

Always follow local utility grounding practices when installing the SEL-2431 Enclosure. As detailed in *Ground the Control Chassis on page 2.5*, make the chassis ground connection first.

Reference *Figure 2.5* for an installation of the SEL-2431 Enclosure.

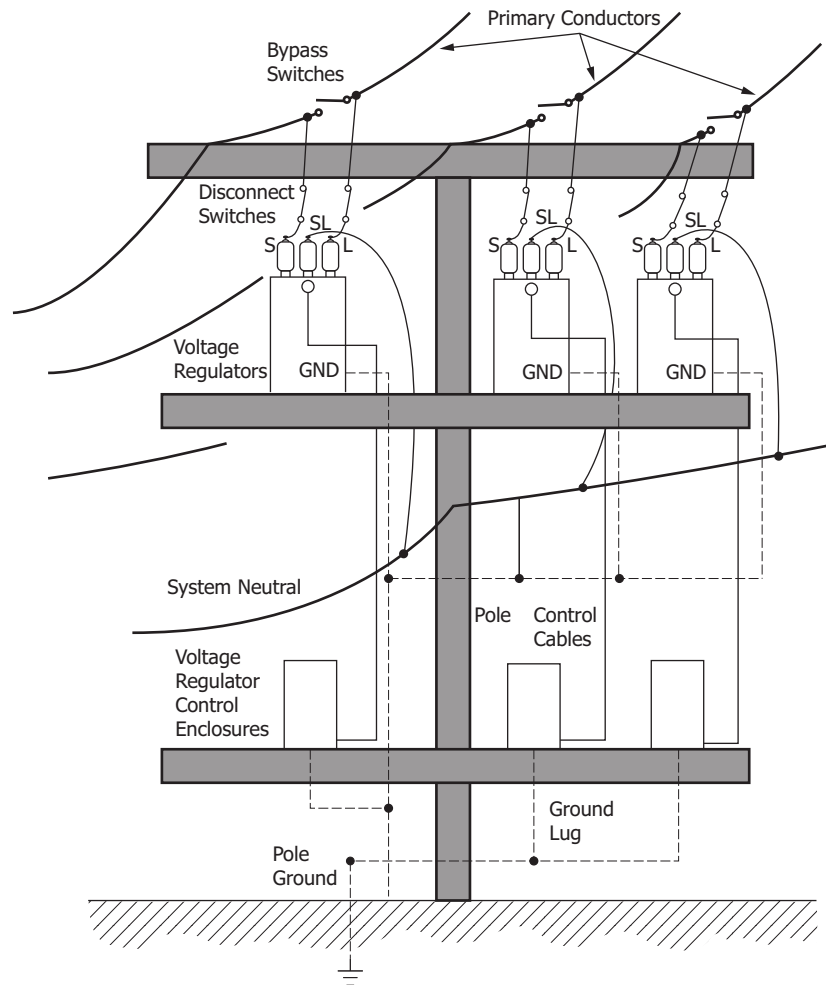

Figure 2.5 Four-Wire Wye System Installation Example

The Enclosure comes standard with a factory-installed mounting bracket. Reference *Figure 1.5* for mounting bracket dimensions.

SEL does not provide the 5/8-inch mounting bolt/washer hardware assembly required for mounting the SEL-2431 Enclosure. Note, the mounting hole on the enclosure is 2 inches in diameter, so any washer used with the mounting bolt must be less than 2 inches in diameter.

Pole Mounting Instructions

NOTE: When installing the SEL-2431 Enclosure directly to a single-phase voltage regulator or to framework in a control house/substation application, refer to *Figure 1.5* for mounting bracket dimensions because each installation will be unique.

NOTE: The SEL-2431 Enclosure will not directly mount to every make/model of voltage regulator. Additional material or hardware may be required to mount the enclosure such as a unistrut channel, nuts/bolts, conduit, or other materials. SEL does not supply the additional materials required to mount the enclosure.

- Step 1. Use the dimensions given in *Figure 1.5* and drill two pilot holes for the lag bolts.
- Step 2. Install one lag bolt/washer for the top mounting bracket.
- Step 3. Lift the enclosure using proper lifting techniques.
- Step 4. Slip the top mounting bracket hole/keyway over the top mounting bolt/washer.
- Step 5. Rest the enclosure on the bolt, settled in the keyway slot.
- Step 6. Install the other lag bolt/washer for the bottom mounting bracket.
- Step 7. Secure both top and bottom mounting bolts/washer assemblies.

Ground the Control Chassis

Figure 1.3 shows the location of the chassis ground, marked by the following symbol:



⚠ WARNING

Ground the SEL-2431 chassis before making any other connections to the control.

The chassis ground screw is a #6-32, 3/8 inch screw. A separate grounding wire, with ring terminals on each end, is provided with the control wiring harness.

Connect the chassis ground on the rear panel of the SEL-2431 to the standard grounding point for a voltage regulator control (e.g., ground stud inside the voltage regulator enclosure).

Connect a Second Voltage or Voltage Questions

See Appendix B: Voltage Connections, Internal Voltage Regulator Wiring, and Voltage Polarity Reversal.

Connect the Wiring Harness From the Voltage Regulator Interface to the SEL-2431

Note the comment at the bottom of Figure 2.6–Figure 2.8, and Figure 2.10: “Wires actually attached to underside.” This becomes apparent in relation to this connector plugging into its corresponding “regulator/control wiring harness” interface, where the interface terminals are labeled the same (Figure B.5, Figure B.6, and Figure B.8).

NOTE: See Table 3.4 for more information on the in-line 2A fuse (Terminal 3 of VOLTAGE connector) in Figure 2.6–Figure 2.10.

The **CURRENT** connector shorts out the current transformer circuit when the connector is disconnected from the rear panel of the SEL-2431. The **VOLTAGES**, **CURRENT**, and **J1** connector views in Figure 2.6–Figure 2.10 correlate with those at the rear panel (see Figure 1.3, Figure C.1, and Figure C.2).

General wiring harness connection procedure:

- Step 1. As detailed in *Ground the Control Chassis on page 2.5*, make the chassis ground connection *first*.

Consult voltage regulator instruction manuals about the need to de-energize voltage circuits and short out current circuits before any connections are made.
- Step 2. Move the **CONTROL POWER** toggle switch of the SEL-2431 to the **OFF** position.
- Step 3. Make any extra connections to connectors **J2** and **J3** at the bottom of the rear panel of the SEL-2431 (see Figure C.2 [bottom] and Figure C.3 and accompanying text).
- Step 4. Connect the voltage regulator side of the wiring harness (the part of the wiring harness illustrated at the bottom of Figure 2.6–Figure 2.16) to the corresponding voltage regulator

CAUTION

Connect only 120 Vac nominal to the SEL-2431 (rear-panel **VOLTAGES** connector and front-panel **EXTERNAL SOURCE** terminals—see Figure C.1).

NOTE: Refer to Setting Voltage Regulator Tap Position on page 3.16 to set the correct tap position of the regulator into the SEL-2431.

Siemens/Howard Voltage Regulator Control Wiring Harness

Notice that *Figure 2.6* applies to both the Siemens and Howard voltage regulators (just different names on the interface terminals). The Siemens interface terminal names will be used in any examples.

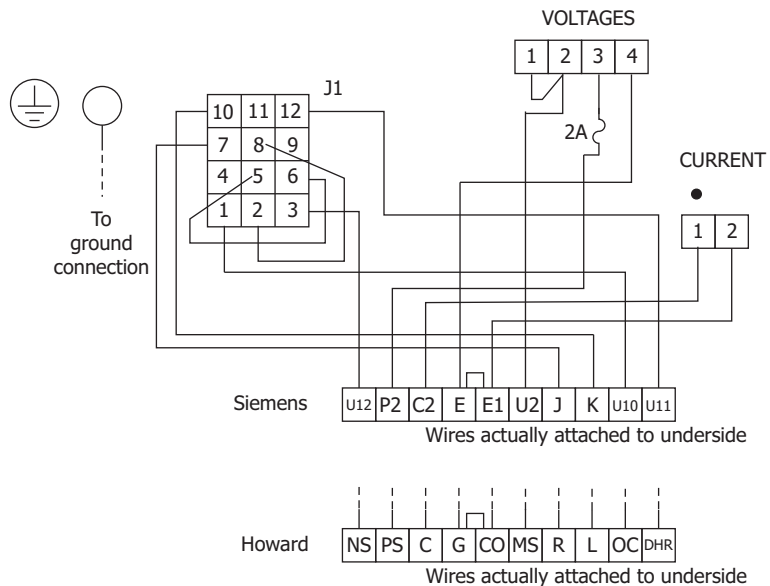

Corresponds to Figure B.5, Figure B.12, and Figure B.13

Figure 2.6 Siemens (Polarized Disconnect Switch [PDS]) or Howard (Connector Terminal Strip [CTS]) Control Wiring Harness

Cooper Voltage Regulator Control Wiring Harness (Traditional Interface)

Notice the “cut line” indicated between positions BR and G on the 18-/10-position fanning strip in *Figure 2.7* and how it corresponds to *Figure B.6* (the regulator/control wiring harness interfaces come as 18- or 10-position). Thus, if a regulator/control wiring harness interface comes as 10 position, the 18-/10-position fanning strip is separated at the cut line and only the resultant 10-position fanning strip is installed. The wire connected to

interface (see correspondence listed in the lower left of the referenced figures or enclosure installation). Follow any specific connection details accompanying these figures.

- Step 5. Connect the **VOLTAGES**, **CURRENT**, and **J1** connectors to the SEL-2431.

Consult voltage regulator instruction manuals about the need to energize voltage circuits and un-short current circuits, now that complete connections are made.

- Step 6. Put the **CONTROL POWER** toggle switch of the SEL-2431 in the **INTERNAL** position.

- Step 7. After the SEL-2431 powers up and the **ENABLED LED** illuminates, immediately put the control in the manual mode (**MANUAL LED** illuminated)—press the **AUTO/MANUAL** pushbutton if need be.

With the SEL-2431 in the manual mode (**MANUAL LED** illuminated), no automatic operation can take place. Once a standard checkout procedure is performed, take the SEL-2431 out of the manual mode, if desired.

Connect the Wiring Harness From the Voltage Regulator Interface to the SEL-2431

position V7 on the leftover 8-position fanning strip piece can be trimmed off (back at Terminal 3 of the VOLTAGES connector) and discarded if no second voltage is to be installed.

A 10-position regulator/control wiring harness interface does not preclude adding a second voltage. Terminal 3 of the VOLTAGES connector is already wired up on the leftover 8-position fanning strip piece (connected to position V7). For such a case, connect a second voltage (V_{S2}) between the following:

- The provided wire on Terminal 3 of the VOLTAGES connector on the SEL-2431 (probably trim off the leftover fanning strip piece)
- Interface Terminal G

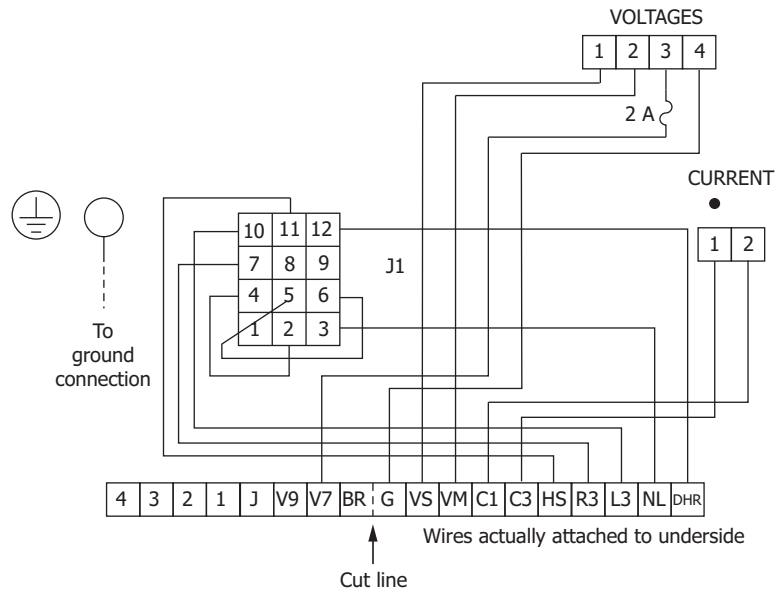

Corresponds to Figure B.6

Figure 2.7 Cooper Traditional (18-/10-Position Fanning Strip) Control Wiring Harness

Figure B.6 is for the traditional Cooper interface—it directly matches Figure 2.7.

Compare the connector terminal labels in Figure 2.8 with the interface terminal labels in Figure B.6. The comparison discrepancies (between Figure 2.8 and Figure B.6) are:

- The four left side terminals are labeled differently
- The connector terminal in Figure 2.8 has an extra G and VS terminal

But all the terminals that are actually used in Figure B.6 and Figure 2.8 correspond exactly in labeling and function.

When inserting the connector in Figure 2.8 into the regulator/control wiring harness interface receptacle in the enclosure, make sure the connector is oriented properly. Most likely the connector will be oriented with the visible screw heads (for tightening the wire connections) facing down. Align connector and receptacle keying before applying pressure to fully engage the connector into the receptacle.

Cooper Voltage Regulator Control Wiring Harness (Dead-Front Interface)

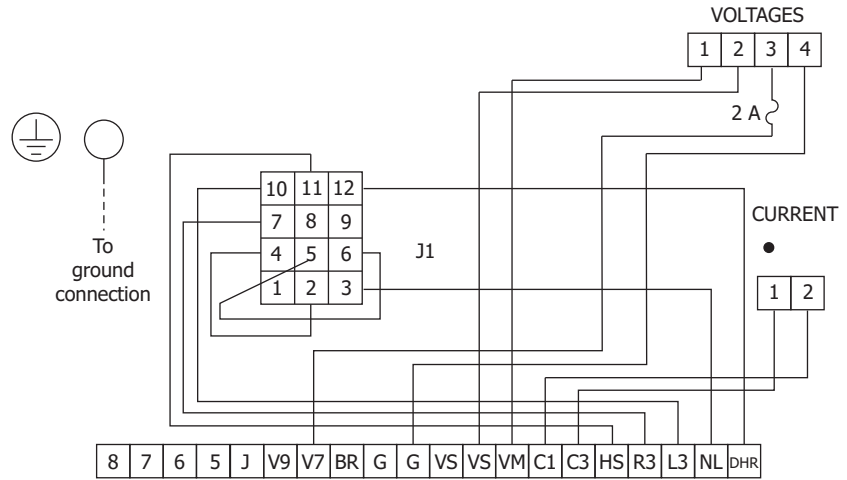

Wires actually attached to underside

Corresponds to Figure B.6

Figure 2.8 Cooper Dead-Front (20-Position Connector) Control Wiring Harness

GE Voltage Regulator Control Wiring Harness (Traditional Interface)

Notice the portion of the wiring harness in *Figure 2.9* that goes from interface Terminal NN8 to one of the interface Terminals NN20, NN21, or NN22. This wire is labeled NN20, NN21, NN22, and is connected to one of these three interface terminals. Determine the appropriate interface terminal to attach to by:

- Noting which of the three interface terminals was connected with the old wiring
- Consulting the voltage regulator nameplate and instruction manual

If the voltage regulator control cabinet contains a knife switch for shorting between NN8 and NN9, make the connections as shown in *Figure 2.9* using the jumper labeled NN8 and NN20, NN21, NN22. If the voltage regulator control cabinet does not contain a knife switch for shorting between NN8 and NN9, attach the jumper labeled NN8 and NN20, NN21, NN22 between Terminals NN9 and whichever terminal has a wire connected to it (NN20, NN21, or NN22).

The curled up wire portrayed on Terminal 3 of the VOLTAGES connector is discussed in *Add a Second Voltage for GE Voltage Regulators (Figure B.2 and Figure B.4)* on page B.5.

A ring terminal on the wiring harness is provided for the GND (voltage regulator enclosure ground) connection.

Connect the Wiring Harness From the Voltage Regulator Interface to the SEL-2431

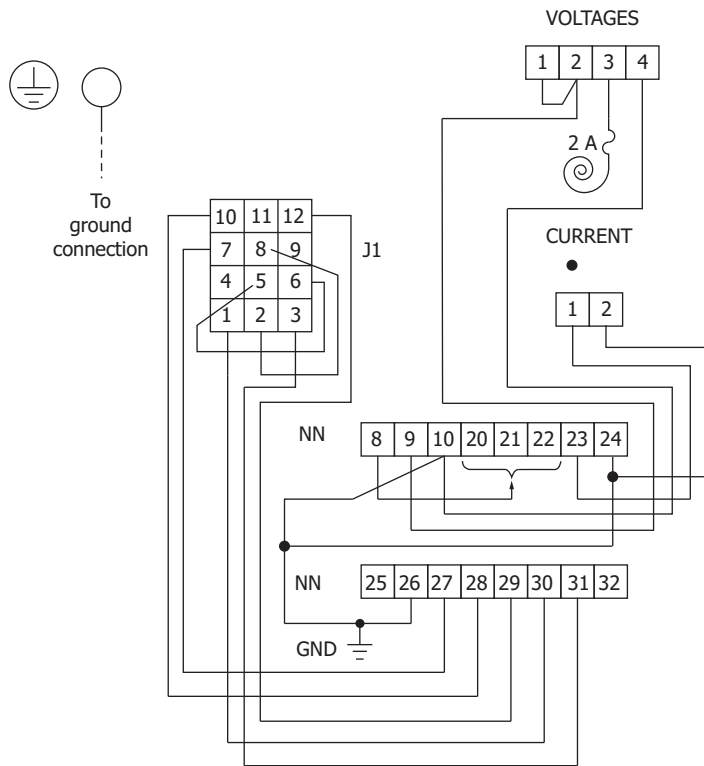

Corresponds to Figure B.7

Figure 2.9 GE Traditional (Fork-Terminal Connections) Control Wiring Harness

GE Voltage Regulator Control Wiring Harness (Power Disconnect Interface)

When connecting this wiring harness, connect the separable connector first. When disconnecting this wiring harness, disconnect the separable connector last. Consult the GE voltage regulator instruction manual for any issues involving the power disconnect.

The curled up wire portrayed on Terminal 3 of the **VOLTAGES** connector is discussed in *Add a Second Voltage for GE Voltage Regulators (Figure B.2 and Figure B.4) on page B.5.*

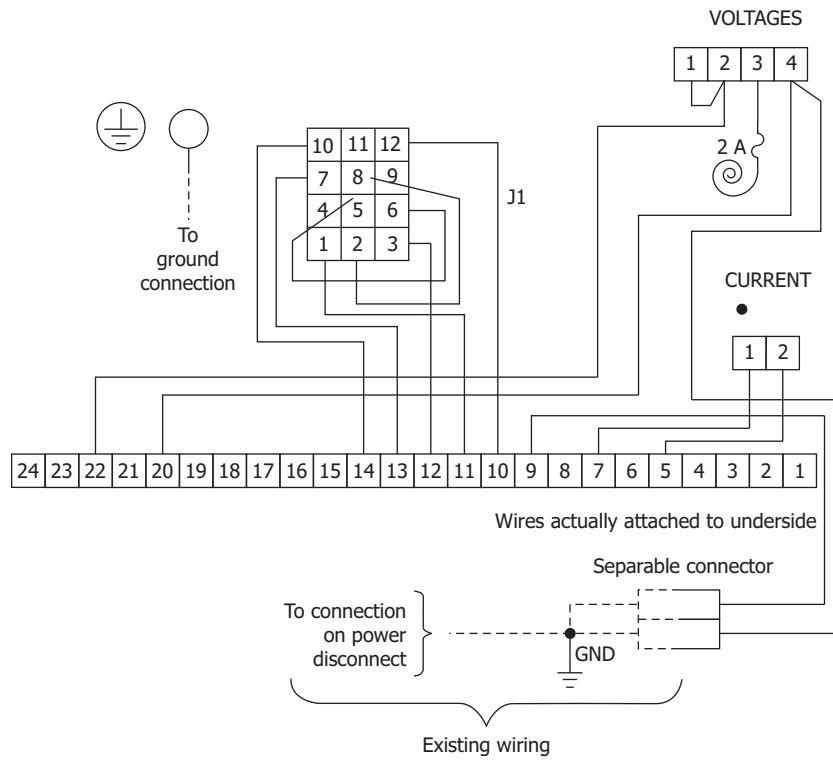

Corresponds to Figure B.8

Figure 2.10 GE Power Disconnect (24-Position Connector) Control Wiring Harness

Generic Control Wiring Harness

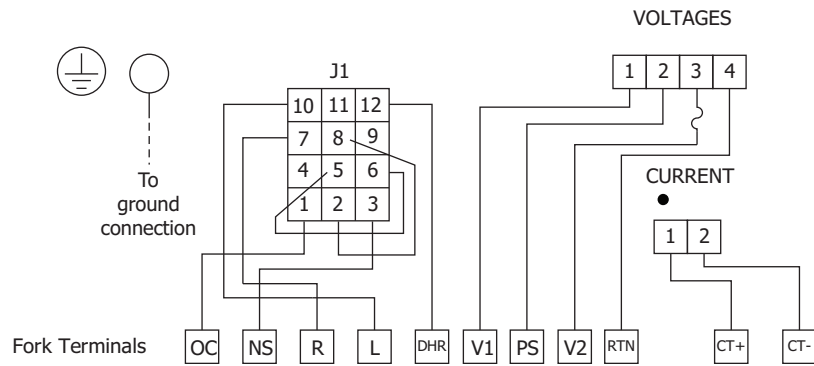

Figure 2.11 Generic Control Wiring Harness (Siemens, Howard, or GE)

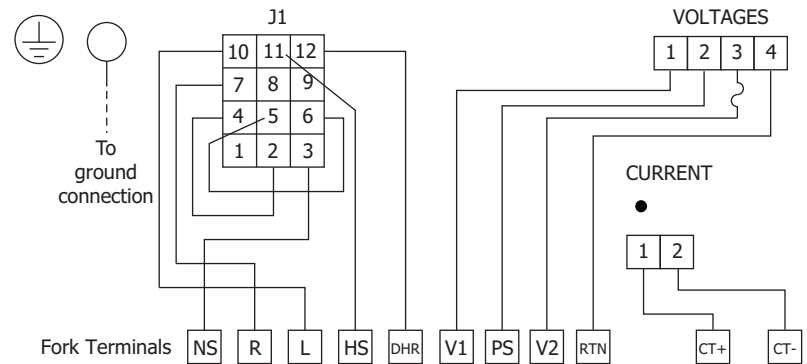
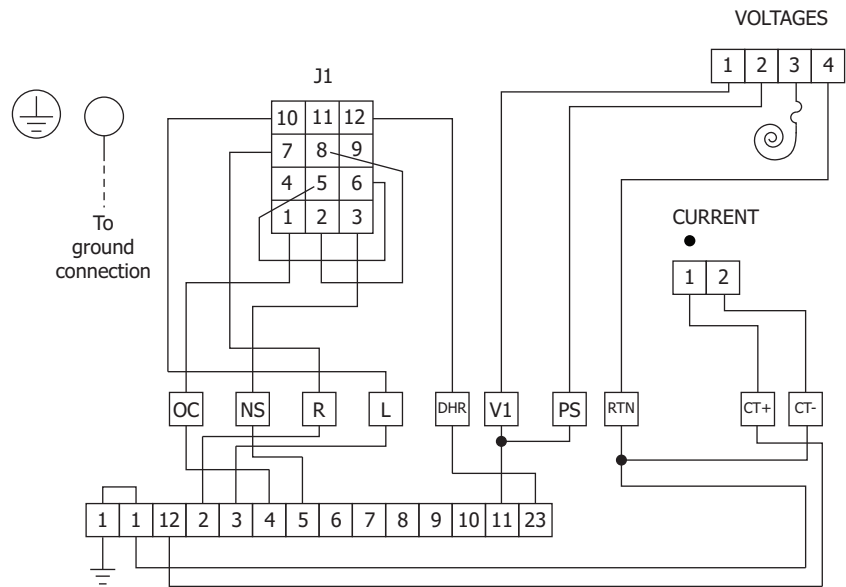

Figure 2.12 Generic Control Wiring Harness (Cooper or McGraw-Edison)

Toshiba CR-3 Voltage Regulator Control Wiring Harness



Corresponds to Figure B.9.

Figure 2.13 Toshiba Manufactured Control Wiring Harness for Toshiba CR-3

Romagnole SVR Voltage Regulator Control Wiring Harness

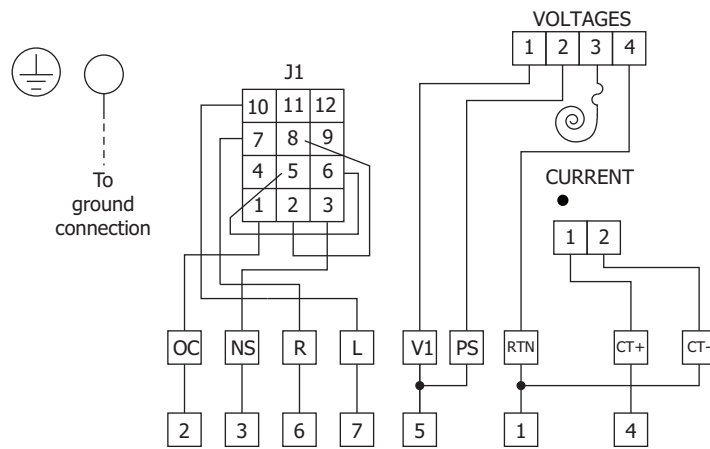
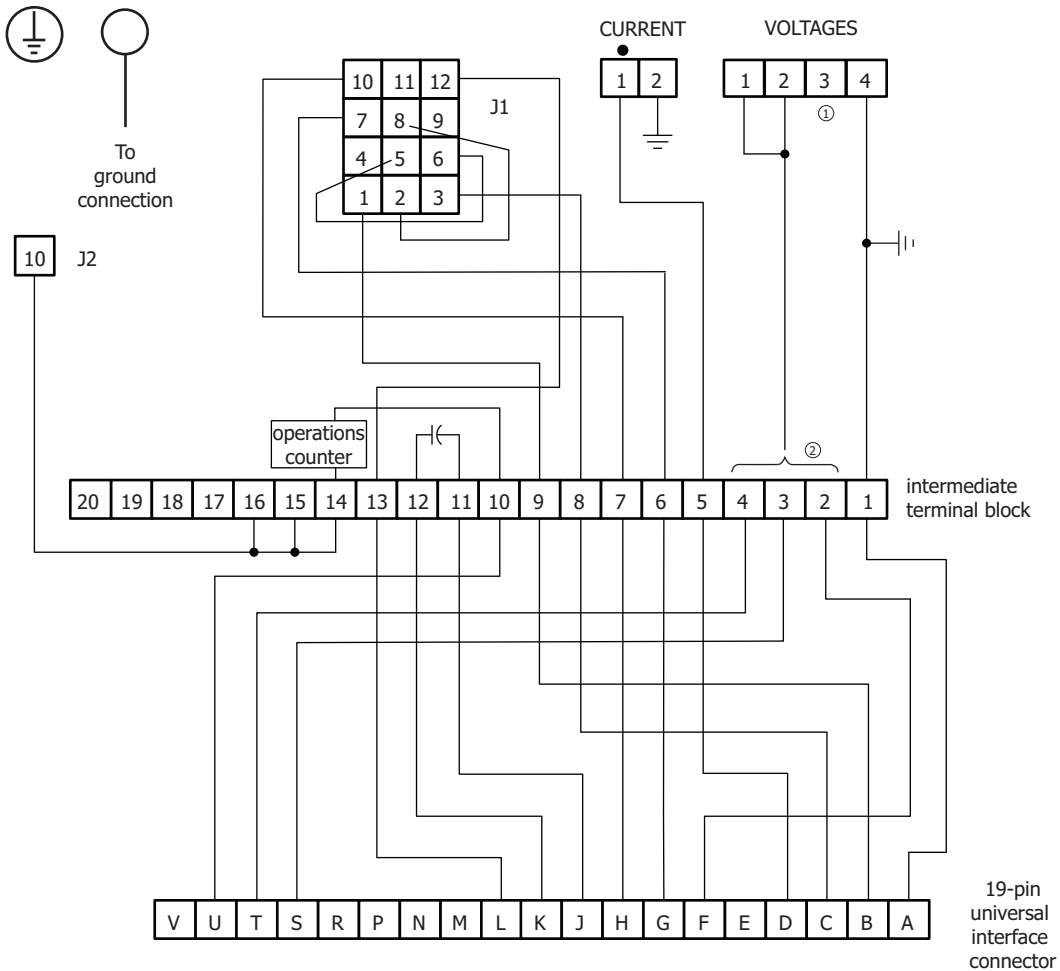

Figure 2.14 Romagnole Manufactured Control Wiring Harness for Romagnole SVR

ITB RAV-2 Voltage Regulator Control Wiring Harness

The ITB RAV-2 regulator implements the universal interface found in IEC 60076-21:2018/IEEE Std C57.15-2017, 11 Universal interface. Consult the ITB RAV-2 instruction manual for additional information.



① Consult the ITB RAV-2 instruction manual about connecting a second voltage V_{S2} (see Figure B.3) to **VOLTAGES** Terminal 3.

② Consult the ITB RAV-2 instruction manual about which voltage V_{S1} tap (#1, #2, or #3; see Figure B.10) should be connected to **VOLTAGES** Terminal 1.

Corresponds to Figure B.10.

Figure 2.15 ITB Manufactured Control Wiring Harness for ITB RAV-2

SEL-2431 Enclosure 19-Pin Universal Interface Terminal Block Connector Wiring

Notice *Figure 2.16* applies to all installations when installing the enclosure. Supported voltage regulator control wiring shall be wired to **TB1** and **TB2** for **VOLTAGES**, **CURRENT**, and **J1** connections to the controller. Reference *Figure 2.6–Figure 2.13* for supported voltage regulator. Refer to *Appendix F: Voltage Regulator Control Enclosure Standard Features and Optional Accessories* for Ratio Correction Transformer wiring.

Connect the Wiring Harness From the Voltage Regulator Interface to the SEL-2431

NOTE: Prior to installing the SEL-2431 Enclosure, verify the existing control cable has adequate length. If control cable is too short, contact the voltage regulator manufacturer for an extended cable.

Use the following instructions to wire the enclosure:

- Step 1. If the existing voltage regulator control is in service, follow your company's policy to remove the device from service.
- Step 2. When replacing an existing controller enclosure or installing a new enclosure, verify that the voltage regulator's control cable has adequate length to reach from the enclosure to the voltage regulator. If the control cable is too short, contact the voltage regulator manufacturer for an extended control cable.
- Step 3. *(Only follow this step if you are replacing an existing controller enclosure with an SEL-2431 Enclosure.)* Prior to disconnecting the existing controller, install the SEL provided wire labels for identifying the supported voltage regulator's control wiring. Disconnect each control wire one at a time and install appropriate wiring label. Continue this process until all control wires have the appropriate labels.
- Step 4. Free the control cable from the old enclosure.
- Step 5. Remove the old enclosure and controller. Mount the new enclosure according to *Mounting the Voltage Regulator Control Enclosure on page 2.3*.
- Step 6. As detailed in *Ground the Control Chassis on page 2.5*, make the chassis ground connection first.
- Step 7. Feed the voltage regulator control cable through the cable sealing gland of the new enclosure.
- Step 8. Terminate supported voltage regulator's control wires on the enclosure's 19-pin universal terminal block (see *Figure 2.16*).
- Step 9. Reference *Section 4: Basic Settings* to configure the SEL-2431.

Connect the Wiring Harness From the Voltage Regulator Interface to the SEL-2431

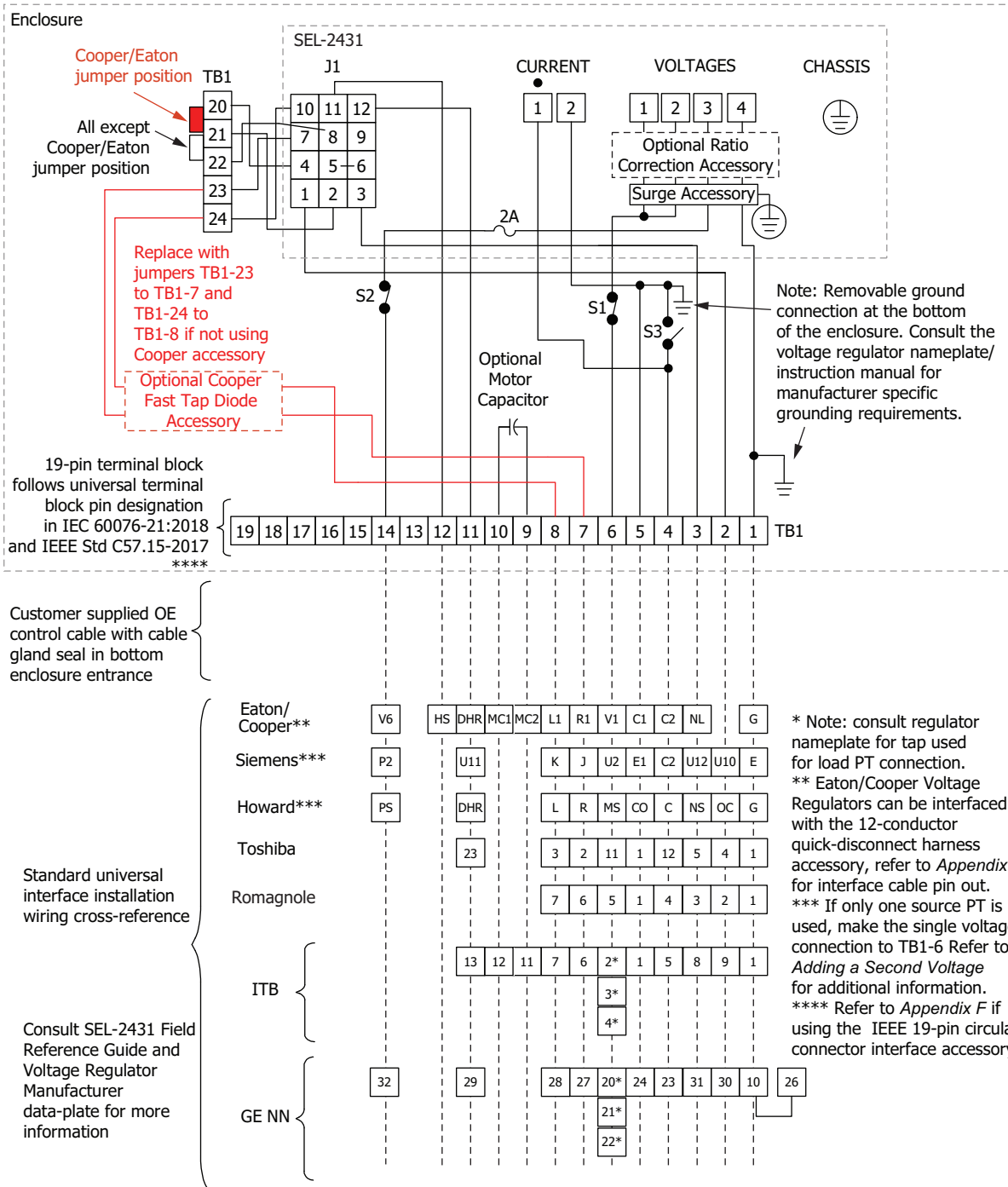

Figure 2.16 SEL-2431 Enclosure Wiring Cross-Reference to Common Voltage Regulator Interfaces

Jumpers and Clock Battery

The password jumper (JMP1-A) and clock battery are features that very infrequently (if ever) need to be set or changed. Access the password jumper (JMP1-A) and/or clock battery by removing Communication Card 1 from the rear of the control. Communication Card 1 is located in the upper left corner of the rear panel. The locations of the password jumper and clock battery are shown in *Figure 2.17*.

NOTE: When installing the communications card, press firmly on the latch until it clicks into place.

Table 2.1 Password Jumper Operation

Jumper Position	Function
ON (in place over both pins)	Disable password protection ^a for serial ports and front panel
OFF ^b (removed/not in place over both pins)	Enable password protection ^a for serial ports and front panel

^a View or set the passwords with the **PASSWORD** command (see Section 9: Communications in the SEL-2431 Voltage Regulator Control Instruction Manual).

^b The OFF position can have the jumper placed over one pin only (to retain the jumper and prevent its loss).

A lithium battery powers the control clock (date and time) if the external power source is lost or removed. The clock battery is a 3 V lithium coin cell. At room temperature (25°C), the clock battery will nominally operate for 10 years at rated load.

If power is lost or disconnected, the clock battery powers the clock. When the voltage regulator control is powered normally from an external source, the clock battery only experiences a low self-discharge rate. Thus, clock battery life can extend well beyond the nominal 10 years because it rarely has to discharge after the voltage regulator control is installed. The clock battery cannot be recharged. If the voltage regulator control does not maintain the date and time after power loss, replace the clock battery.

CAUTION

Equipment components are sensitive to electrostatic discharge (ESD). Undetectable permanent damage can result if you do not use proper ESD procedures. Ground yourself, your work surface, and this equipment before removing any cover from this equipment. If your facility is not equipped to work with these components, contact SEL about returning this device and related SEL equipment for service.

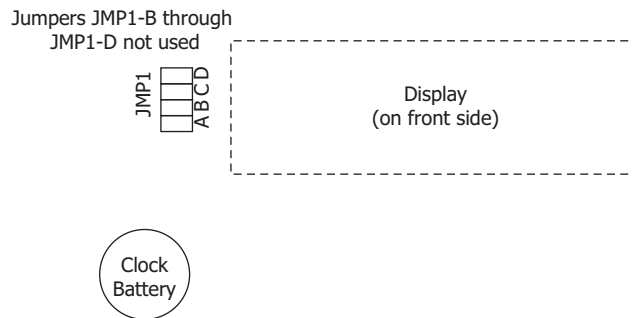

Figure 2.17 Location of Password Jumper JMP1-A and Clock Battery on Rear of the Circuit Board

This page intentionally left blank

Section 3

Front-Panel Interface

Overview

The SEL-2431 Voltage Regulator Control front panel makes data collection and control quick and efficient. Use the front panel to analyze operating information, view and change device settings, and perform control functions. The SEL-2431 features a straightforward menu-driven control structure presented on the front-panel LCD. Front-panel LED indicators provide a fast means of checking operation status. You can perform often-used control actions rapidly by using the large direct-action pushbuttons. Features available from the front panel include the following:

- Reading current and voltage metering
- Inspecting indication LEDs
- Accessing settings
- Controlling device operations
- Viewing diagnostics
- Reset regulator drag hands
- Control power switch
- Control configuration pushbuttons and indication
- Tap up/down motor control and indication
- External power source terminals
- Fuses for control, motor, and external power source
- Voltmeter test terminals

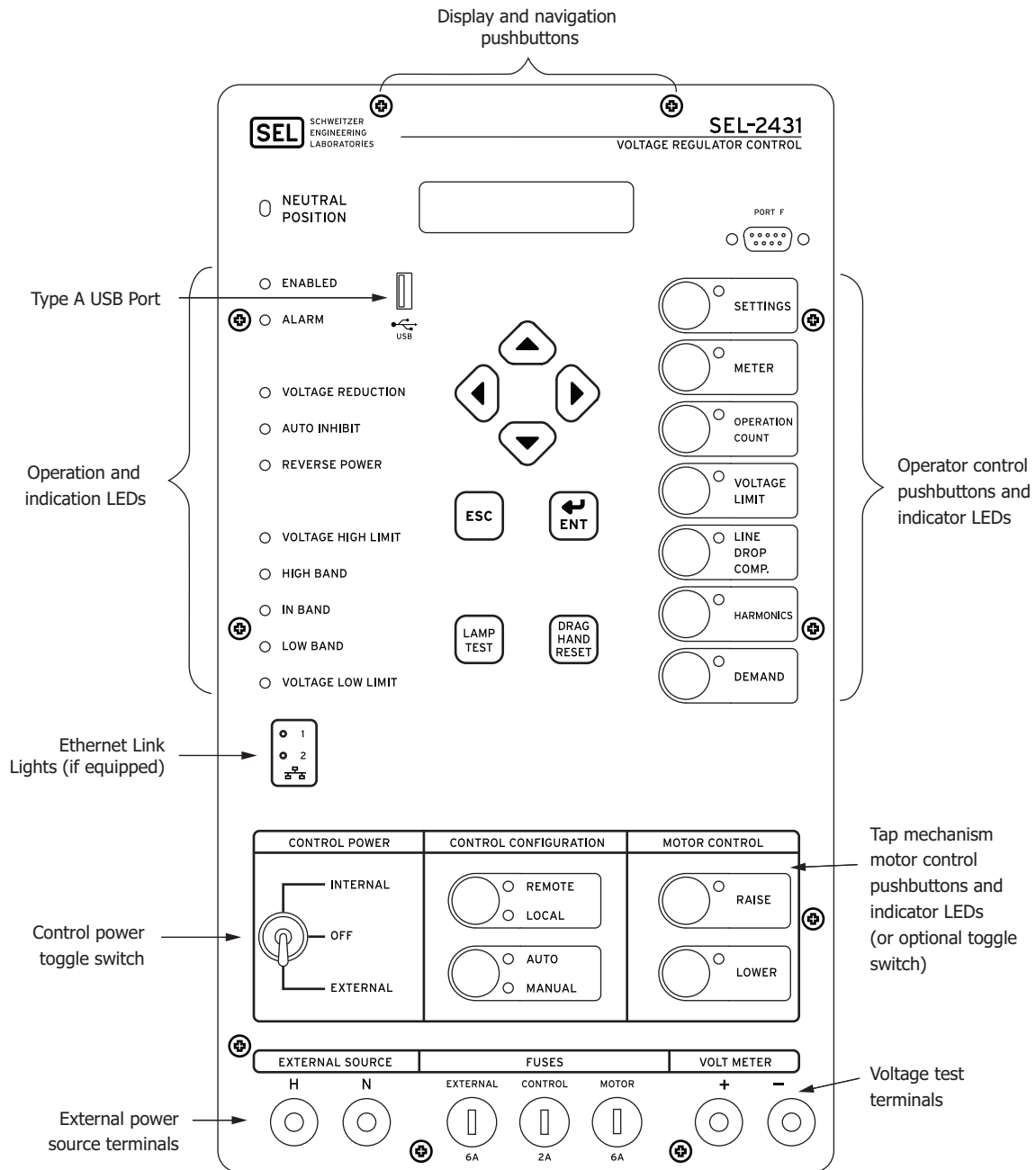

Figure 3.1 Different Sections of the SEL-2431 Front Panel

Control Power, Control Configuration, and Motor Control

Figure 3.2 shows the control power switch, control configuration pushbuttons, and motor control pushbuttons section of the SEL-2431 front panel.

Figure 3.3 shows similar but with the toggle switch option for motor control.

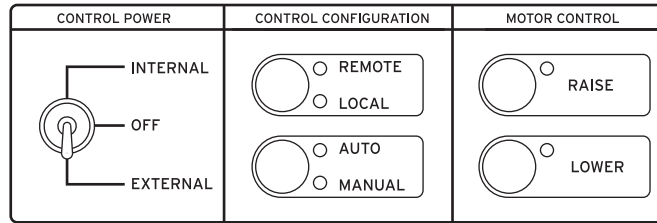

Figure 3.2 Control Power, Control Configuration, and Motor Control Section of the SEL-2431 Front Panel (Pushbutton Version)

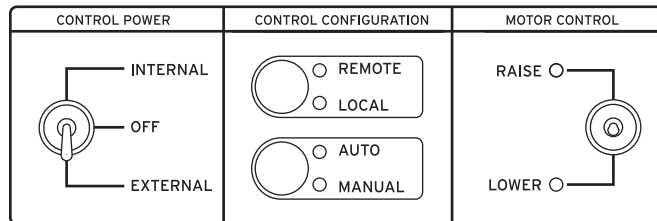

Figure 3.3 Control Power, Control Configuration, and Motor Control Section of the SEL-2431 Front Panel (Toggle Switch Version)

CONTROL POWER Switch

Refer to *Figure C.1*. The **CONTROL POWER** toggle switch has three positions:

- **INTERNAL:** This is the position for normal operation. All the voltages wired to the rear-panel **VOLTAGES** connector are switched in/connected to energize the power supply and voltage input V_{S1} (voltage input V_{S2} is energized, too, if a second voltage is available at Terminal 3 of the **VOLTAGES** connector).
- **OFF:** All the voltages wired to the rear-panel **VOLTAGES** connector are switched out/disconnected to de-energize the SEL-2431.
- **EXTERNAL:** The **EXTERNAL SOURCE** terminals are switched in/connected to energize the power supply and voltage inputs from a 120 Vac nominal external source (connected to the **EXTERNAL SOURCE** terminals).

Notice in *Figure C.1* that when the **CONTROL POWER** toggle switch is in the **EXTERNAL** position, the **EXTERNAL SOURCE** Terminal H is paralleled out to the power supply and the two voltage inputs (V_{S1} and V_{S2})—they all three see the same voltage when the **CONTROL POWER** toggle switch is in the **EXTERNAL** position (if a 120 Vac nominal external source is connected to the **EXTERNAL SOURCE** terminals). Notice also the proper polarity connections for the 120 Vac nominal external source and recommended, user-provided fuse in the external “hot” (Terminal H) circuit connection.

CONTROL CONFIGURATION Pushbuttons and LEDs

The **CONTROL CONFIGURATION** pushbuttons allow four modes of operation:

1. **LOCAL/MANUAL** mode—LOCAL and MANUAL modes selected
2. **LOCAL/AUTO** mode—LOCAL and AUTO modes selected
3. **REMOTE/MANUAL** mode—REMOTE and MANUAL modes selected
4. **REMOTE/AUTO** mode—REMOTE and AUTO modes selected

NOTE: The SEL-2431 factory-default settings prevent the control from entering the REMOTE/MANUAL mode.

Front-Panel SELoGIC Settings REMOTSV, LOCALSV, AUTOSV, and MANULSV for Control Configuration in Section 10: Front-Panel Operations in the SEL-2431 Voltage Regulator Control Instruction Manual explains how the operation of the CONTROL CONFIGURATION pushbuttons can be altered from factory-default settings, if desired.

Figure 3.4 shows the functions/schemes enabled by the different REMOTE, LOCAL, AUTO, and MANUAL modes (corresponding LED illuminates). Notice that no particular functions/schemes are enabled by the LOCAL mode. LOCAL mode is equivalent to a “REMOTE off/disabled” mode.

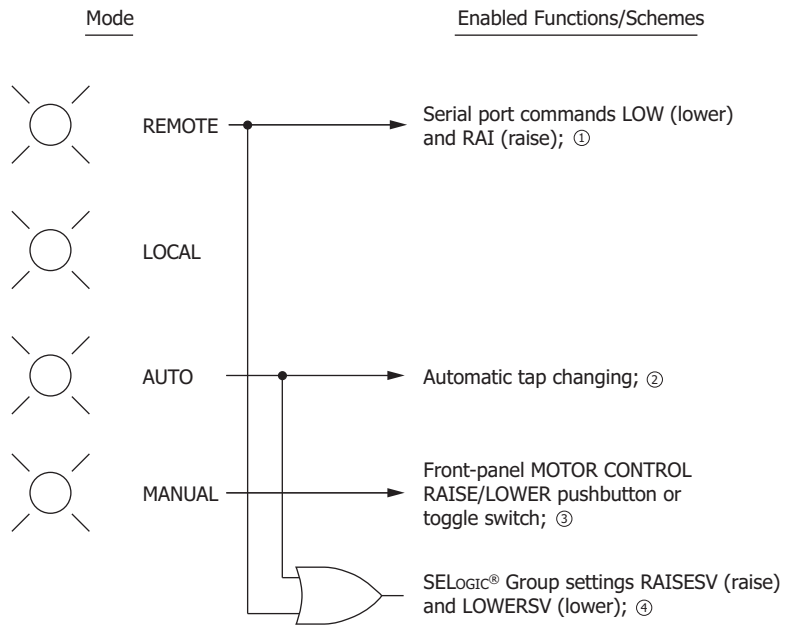

① See LOW Command and RAI Command in Section 9: Communications in the SEL-2431 Voltage Regulator Control Instruction Manual.

② See Basic Group Settings on page 4.6, and also see Section 3: Control Algorithms, Section 4: Control Operating Modes, and Appendix G: Definite Time Characteristics in the SEL-2431 Voltage Regulator Control Instruction Manual.

③ See Figure 3.2 and Figure 3.3, MOTOR CONTROL Pushbuttons on page 3.4, and MOTOR CONTROL Toggle Switch on page 3.5.

④ See Other Raise/Lower Methods in Section 5: Tap Operations in the SEL-2431 Voltage Regulator Control Instruction Manual.

Figure 3.4 Functions/Schemes Enabled by the Different REMOTE, LOCAL, AUTO, and MANUAL Modes

MOTOR CONTROL Pushbuttons

The MOTOR CONTROL RAISE and LOWER pushbuttons allow you to manually raise and lower the tap position of the regulator when the SEL-2431 control is in the manual mode as shown by the MANUAL pushbutton and LED to the left of the RAISE and LOWER pushbuttons. The RAISE and LOWER pushbuttons are momentary. You must press and hold each button when a manual RAISE or LOWER operation takes place. Continue to hold these buttons until you hear the voltage regulator execute a tap operation.

When the regulator is regulating voltage in the forward direction, raising the tap position will raise the regulated voltage. Lowering the tap position when regulation is in the forward direction will lower the regulated voltage.

Conversely, when the regulator is regulating voltage in the reverse direction, raising the tap position will lower the regulated voltage. Lowering the tap position when regulation is in the reverse direction will raise the regulated voltage.

The **RAISE** LED shows when the tap changer motor is running in the raise direction (tap position). The **LOWER** LED shows when the tap changer motor is running in the lower direction (tap position). Refer to *Figure C.2* for the Raise/Lower outputs and **MOTOR CONTROL RAISE** and **LOWER** pushbuttons.

MOTOR CONTROL Toggle Switch

NOTE: An SEL-2431 with the toggle switch **MOTOR CONTROL RAISE/LOWER** option can raise and lower the tap mechanism when the SEL-2431 control is disabled. The pushbutton **MOTOR CONTROL RAISE/LOWER** option cannot raise and lower the tap mechanism when the SEL-2431 is disabled.

The **MOTOR CONTROL RAISE/LOWER** toggle switch allows you to also raise and lower the tap position of the regulator when the SEL-2431 control is in the manual mode similar to the previous section describing the pushbutton version of the SEL-2431.

The **RAISE/LOWER** toggle switch is a three-position switch. To execute a manual **RAISE**, push the toggle switch up. To execute a manual **LOWER**, push the toggle switch down. Note that the switch will return to the center position when you release it. You must press and hold the toggle switch into the **RAISE** or **LOWER** position until you hear the voltage regulator execute a tap operation.

The **RAISE/LOWER** toggle switch is inoperative (internal switch in series with it is open; see *Figure C.3*) if any of the following occur:

- The control is in automatic mode (**AUTO** LED illuminated).
- A raise or lower operation (via the raise and lower output contacts in the parallel circuits) is in progress.
- A settings change or settings group change is in progress.

Otherwise, the **RAISE/LOWER** toggle switch is operative (internal switch in series with it is closed).

USB Flash Drive Support

NOTE: For faster response time while using the USB feature, minimize the number of files and folders in the root of the USB flash drive. (Files and folders that are not in a folder are at the root of the drive.)

The Type A USB port is used to connect a USB flash drive (commonly referred to as a thumb drive or memory stick) to the SEL-2431.

When a USB flash drive is inserted into the port, the front-panel HMI will automatically display the menu items associated with the USB. Those menu items and their descriptions are listed in *Table 3.1*.

Compatible USB Flash Drives

The SEL-2431 is USB 2.0 compatible and will interface with any USB 2.0 *certified* flash drive. Not every flash drive that says “USB 2.0” is USB 2.0 certified. Certified flash drives are tested to the USB standard, and will display a red and blue logo stating “Certified USB” or “Certified HI-SPEED USB” on the packaging. You can also verify if a USB flash drive is certified by looking up the part number of the flash drive on the website, www.usb.org.

The SEL-2431 will interface with most USB flash drives, even if they are not certified, but the speed of data transfer and the data integrity could be significantly compromised.

Using the USB to Gain Level 2 Access

The USB flash drive may be used as a means of authenticating a user. In other words, if a USB authentication key (containing the 2AC password) is stored on the USB flash drive, inserting the USB flash drive into the USB port will grant the user Level 2 access to the front panel. As long as the USB flash drive

remains inserted in the device, the front panel will continue to grant Level 2 access to the user. The USB authentication key must be stored on the USB flash drive using the USB menu in ACSELERATOR QuickSet. See *Section 10: Front-Panel Operations* in the *SEL-2431 Voltage Regulator Control Instruction Manual* for more information about security with the USB authentication key on the USB flash drive.

Using Front-Panel Pushbuttons During USB Operations

After connecting a USB flash drive to the SEL-2431, use the first six navigation buttons described in *Table 3.4* to navigate through the menus. When the device is transferring files to or from the USB flash drive (such as during a firmware upgrade), the navigation buttons are disabled. The only exception to this is during the Read Reports operation when the **ESC** button can be pressed to cancel the read operation.

Removing the USB Flash Drive

Do not disconnect the USB flash drive from the SEL-2431 during a file transfer operation. To confirm it is safe to disconnect the USB flash drive, disable the Automatic Backup feature and press the **ESC** button to return to the default display (the rotating display) before removing the USB flash drive.

Table 3.1 USB Main Menu Choices

Menu Text	Description
Send Settings to the SEL-2431	Send settings to the device from the USB flash drive
Read Settings from the SEL-2431	Read the settings from the device to the USB flash drive
Read Reports from the SEL-2431	Read the reports from the device to the USB flash drive
Automatic Report Backup	Enable automatic backup of reports to the USB flash drive
Send Firmware to the SEL-2431	Send firmware file to the device from the USB flash drive
Last Firmware Update	View status of last firmware update
Erase USB Device Data	Erase all the files on the USB flash drive

Send Settings

Send new settings from the USB flash drive to the SEL-2431 Voltage Regulator Control. Settings files can be stored on the USB flash drive using either of the following methods.

- Using ACSELERATOR QuickSet. See *Section 2: PC Software* in the *SEL-2431 Voltage Regulator Control Instruction Manual*.
- Reading the settings from another SEL-2431, using the **Read Settings** function

The settings files are stored in a subfolder under the **SETTINGS** folder on the USB flash drive. The HMI will prompt you to select the subfolder containing the settings to apply to the device. If there is only one subfolder under the **SETTINGS** folder, the device will automatically select that folder.

The SEL-2431 will back up its settings files to the USB flash drive before copying the new settings from the USB flash drive. If the settings sent from the USB flash drive are not valid for any reason (i.e., wrong settings version or other settings error), the SEL-2431 will detect that error and will revert back to the settings stored on the device before the Send Settings operation started. The SEL-2431 will not stop with partially applied settings. The only exception

to this is if the USB flash drive is too full to store the original settings for backup, in which case the HMI will warn you, and prompt for whether you want to continue with the Send Settings operation.

Read Settings

Read the settings from the SEL-2431 to the USB flash drive. The settings files stored on the device will be stored on the USB flash drive in a subfolder of your choice under the **SETTINGS** folder. The HMI will prompt you to select which subfolder you want to use, or you may create a new subfolder. As mentioned in *Send Settings*, settings files that are read from one SEL-2431 to a USB flash drive can be directly applied to another SEL-2431 if the firmware on the two devices is compatible with the same settings version.

Read Reports

Retrieve the reports listed in *Table 3.2*. The reports retrieved will be “human-readable” copies of the reports stored in the onboard memory in the SEL-2431. Each file will be stored under the **REPORTS** folder, in a subfolder of your choice. The HMI will prompt you to select which folder you want to use, or you can create a new folder. See *Section 10: Front-Panel Operations* in the *SEL-2431 Voltage Regulator Control Instruction Manual* for more information about the directory structure.

Table 3.2 Report Files Stored During Read Reports and Automatic Backup

Report Type	File Description	Similar to Command	Included in Automatic Backup
Event Report summary	HIS.TXT file contains a summary of each event report	HIS	Y
Event Report	.CEV files contain compressed event reports	CEV	Y
SER	SER.TXT contains each SER entry	SER	Y
Signal Profile	PRO.TXT contains Signal Profile entries	PRO	Y
Tap Count summary	TAP.TXT contains the latest tap position change counts (total and per-tap position)	TAP	Y
Metering Data	MET.TXT contains instantaneous metering data	MET	N
Demand Metering Data	MET_D.TXT contains metering demand and peak demand data	MET D	N
Energy Metering Data	MET_E.TXT contains energy metering data	MET E	N
Harmonic and THD Metering Data	MET_H.TXT contains instantaneous harmonic and THD metering data	MET H	N
Maximum/Minimum Metering Data	MET_M.TXT contains maximum/minimum metering data	MET M	N
Status Report	STA.TXT contains voltage regulator control self-test status	STA	N

Automatic Report Backup

Enable automatic backup of reports to the USB flash drive to effectively expand the amount of historical data that can be stored. When you enable or disable Automatic Report Backup, the SEL-2431 stores this decision in a file on the USB flash. This means that if the USB flash drive is removed and then reinserted, Automatic Report Backup will automatically resume.

The automatic backup feature can be used to save a longer history of reports than is available using only the onboard memory in the SEL-2431. The reports that will be automatically saved when this feature is enabled are listed in *Table 3.2*. Data on the USB flash drive are stored in a first-in, first-out fashion; when the flash drive becomes full, the older data are deleted to make room for new data.

The files will be stored under the **REPORTS** folder, in a subfolder of your choice. The HMI will prompt you to select which folder you want to use, or you can create a new folder. See *Section 10: Front-Panel Operations* in the *SEL-2431 Voltage Regulator Control Instruction Manual* for more information about the directory structure.

Send Firmware

Perform a firmware update on the SEL-2431, loading the firmware file from the USB flash drive. If there is only one .zds firmware file stored in the **FIRMWARE** folder, the device will select that file. If there is more than one file, the HMI will prompt you to select which file you want to use. The SEL-2431 will verify that the file is digitally signed by Schweitzer Engineering Laboratories before installing the firmware. Do not remove the USB flash drive until after the HMI has displayed the message *Restarting*. When the device restarts, it will display the status of the firmware update. The status will indicate success or failure with a reason for failure.

Last Firmware

View the date and time the last firmware update was performed, and the status of the update. If the update failed, the device will display a reason for the failure.

Erase USB Flash Drive

Erase all the files on the USB flash drive. If the USB flash drive contains a USB authentication key, the SEL-2431 will ask if you want to remove that file.

External Source Terminals, Fuses, and Voltmeter Test Terminals

Figure 3.5 shows the external source terminals, fuses, and voltmeter test terminals section of the SEL-2431 front panel.

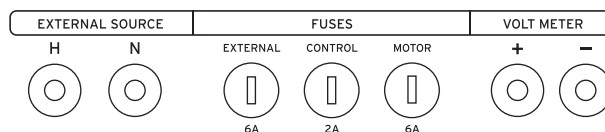

Figure 3.5 External Source Terminals, Fuses, and Voltmeter Test Terminals Section of the SEL-2431 Front Panel

EXTERNAL SOURCE Terminals

The **EXTERNAL SOURCE** terminals allow you to power the SEL-2431 control from an external 120 Vac source. Apply the positive or “hot” voltage source leg to the Terminal H. Apply the negative or “neutral” voltage source leg to the Terminal N. Place the **CONTROL POWER** switch in the **EXTERNAL** position to power the control from the external 120 Vac source.

IMPORTANT: To provide complete fuse protection when connecting to an external source, it is recommended that a user-provided fuse (equivalent to the **EXTERNAL 6A** fuse) be installed in the “hot” lead of the external source as shown in Figure C.1.

Read/study the following information before connecting a 120 Vac nominal external source to the **EXTERNAL SOURCE** terminals:

- *CONTROL POWER* Switch on page 3.3
- *Figure C.1*

FUSES

Table 3.3 Fuses

Fuse	Replacement Part No.	Function
EXTERNAL 6A	Bussman MDL-6 (6A, 250 VAC) or equivalent	Protect against connecting an external source with inadvertently swapped leads
CONTROL 2A	Bussman MDL-2 (2A, 250 VAC) or equivalent	Protect the power supply
MOTOR 6A	Bussman MDL-6 (6A, 250 VAC) or equivalent	Protect most all the interconnected 120 Vac circuitry of the SEL-2431 and the voltage regulator (e.g., raise/lower circuits)
In-line 2A fuse (Terminal 3 of VOLTAGES connector)	Bussman MDL-2 (2A, 250 VAC) or equivalent	Protect the second voltage input

Figure C.1 shows the **EXTERNAL 6A**, **CONTROL 2A**, and **MOTOR 6A** fuses. *Figure 2.6* through *Figure 2.10* show in-line 2 A fuse (Terminal 3 of **VOLTAGES** connector).

VOLTMETER Test Terminals

NOTE: Voltage measured at the **VOLTMETER** terminals can differ from VS or VL in metering because of voltage base normalization (see *Figure B.1* through *Figure B.4*, with accompanying notes, and Appendix E: Voltage Base and Ratio Correction Transformer).

NOTE: Because the voltmeter terminals are impedance-protected, low-impedance multimeters may not measure the voltage accurately. The Analog Quantity VMETER reports the voltage at the voltmeter terminals.

The **VOLTMETER +** terminal is impedance-protected, as shown in *Figure C.1*. The internal switch shown in series with this terminal selects the voltage to monitor, V_{S1} or V_{S2} (refer to *Figure B.1* through *Figure B.4* for the origin of these voltage connections).

With factory-default settings, this internal switch directs the present load-side voltage (depending on power flow direction) to the **VOLTMETER** terminals. If power flow is in reverse, the conventional source side becomes the present load side.

If there is no second voltage V_{S2} connected (Global setting 2ND_PT := N), this internal switch just stays in the V_{S1} position, as shown in *Figure C.1*. This is the same position that this internal switch would be in if the SEL-2431 lost power (e.g., **CONTROL 2A** fuse blew) or otherwise failed.

Front-Panel Settings VTJ_MODE and VTJ_L for Voltmeter Test Terminals in Section 10: Front-Panel Operations in the SEL-2431 Voltage Regulator Control Instruction Manual explains how the operation of the **VOLTMETER** test terminals can be altered from factory-default settings, if desired.

Display and Navigation Pushbuttons

Figure 3.6 shows the display and navigation pushbutton area of the front panel.

The **LAMP TEST** and **DRAG HAND RESET** pushbuttons are also shown in *Figure 3.5*. Their functions are described in *Table 3.4*.

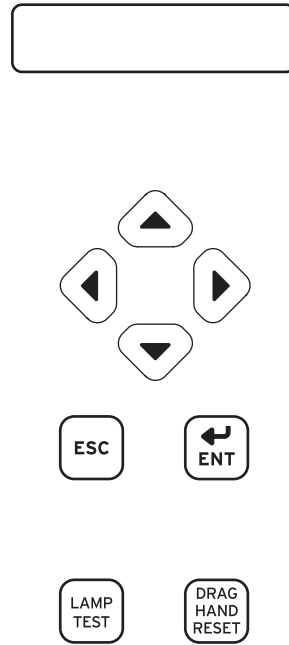

Figure 3.6 Display and Navigation Pushbuttons

Default Display

NOTE: If Tap Position is reported as “unknown,” that means the tap position counter is at 0, but the Neutral Position switch did not assert. This indicates something is wrong with the tap position tracking, or indicates that the SEL-2431 has never been synchronized to the voltage regulator tap position. In any case, it is not safe to consider the voltage regulator to be in the neutral tap position.

At two-second intervals, the following default displays sequentially scroll by:

- Load voltage value (V sec.)
- Load current value (A pri.)
- Real power value (kW, single-phase)
- Reactive power value (kVAr, single-phase)
- Present tap position
- Test jack voltage as measured on voltmeter terminals
- Hardware Alarm – Status Failure if any status self-test fails
- Neutral signal not detected if present tap = 0 but neutral position switch is not detected. It is unsafe to bypass the voltage regulator in this condition.
- Tap Position discrepancy if current tap position does not agree with state of the operations counter switch (TPCHNGR = Siemens or Howard)

To change these default displays, see *Display Points in Section 10: Front-Panel Operations* in the *SEL-2431 Voltage Regulator Control Instruction Manual*.

Contrast

You can adjust the LCD screen contrast to suit your viewing angle and lighting conditions. To change screen contrast, press and hold the **ESC** pushbutton for two seconds. The SEL-2431 displays a contrast adjustment box. Pressing the **Right Arrow** pushbutton increases the contrast. Pressing the **Left Arrow** pushbutton decreases the screen contrast. When you are finished adjusting the screen contrast, press the **ENT** pushbutton.

Front-Panel Automatic Messages

The SEL-2431 automatically displays alert messages. Any message generated due to an alert condition takes precedence over the normal rotating display and the main menu. Alert conditions include these significant events:

- Status warning
- Status failure

Front-Panel Security

Front-Panel Access Levels

The SEL-2431 front panel typically operates at Access Level 1 and provides viewing of device measurements and settings. Some activities, such as editing settings and controlling output contacts, are restricted to those operators who know the Access Level 2 password.

Access Level 2 Password Entry

When you try to perform an Access Level 2 activity, the voltage regulator control determines whether you have entered the correct Access Level 2 password. If you have not entered the correct password, the voltage regulator control displays the screen shown in *Figure 3.7*, prompting you to enter the password.

NOTE: The factory-default passwords are:

Access Level 1: **OTTER**
 Access Level 2: **TAIL**

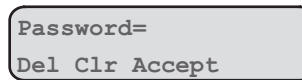

Figure 3.7 Password Prompt Display

In general, the SEL-2431 determines the password validity in the following way:

1. The user enters a password.
2. The device compares this password with all passwords in the device. The comparison starts with the highest level password and works toward the lowest level password.
3. If a password match exists, the access level is set to the level where the password matches.
4. If no match exists, the device displays *Invalid Password*. If the user acknowledges this message (by pressing the **ENT** pushbutton), the device again prompts for a password, and a third time if no match exists after the second attempt and the user acknowledged the displayed message. Upon three failures, the device displays the following message: *Invalid Password Access denied. WARNING: ACCESS BY UNAUTHORIZED PERSONS STRICTLY PROHIBITED.* When the user acknowledges this message, the device returns to the default display and the user starts from the beginning.
5. If the new access level still does not give the user access to the entry, the device displays the following message (after the user acknowledged the displayed message): *Insufficient Access Level, Level xAC Required*, where *xAC* is the access level required (*ACC* for Access Level 1, *2AC* for Access Level 2).

Note that the HMI always starts at (and returns to after idle time-out) Access Level 1 (*ACC*).









Front-Panel Menus and Screens

Navigating the Front-Panel Menus

The SEL-2431 front panel gives you access to most of the information that the voltage regulator control measures and stores. You can also use front-panel controls to view or modify device settings. All of the front-panel functions are accessible through use of the six-button keypad and LCD, as shown in *Figure 3.6*.

Use the front-panel keypad pushbuttons to maneuver within the front-panel menu structure, and the **LAMP TEST** pushbutton to illuminate all LEDs. *Table 3.4* describes the function of each pushbutton in *Figure 3.6*.

Table 3.4 Navigation Pushbutton Functions

Pushbutton	Function
 Up Arrow	Move up within a menu or data list. While editing a setting value, increase the value of the underlined digit. Holding this key down moves the cursor up one line every 1.3 seconds.
 Down Arrow	Move down within a menu or data list. While editing a setting value, decrease the value of the underlined digit. Holding this key down moves the cursor down one line every 1.3 seconds.
 Left Arrow	Move the cursor to the left. Holding this key down repeats the cursor left movement every 1.3 seconds.
 Right Arrow	Move the cursor to the right. Holding this key down repeats the cursor right movement every 1.3 seconds.
 ESC	Escape from the present menu or display without saving changed information. Move from the default display to the MAIN display. Hold for 2 seconds to display contrast adjustment screen.
 ENT	Move from the default display to the MAIN display. Select the menu item at the cursor. Select the displayed setting to edit that setting.
 LAMP TEST	All LEDs illuminate as long as the button is pushed.
 DRAG HAND RESET	Pressing this button will reset the drag hands on the regulator's tap position dial to the current tap position (see <i>Figure C.2</i>).

NOTE: Do not press and hold the **DRAG HAND RESET** pushbutton. Doing so causes the DHR bit to assert for the duration of the pressing action. Pressing and releasing the pushbutton pulses the bit as required by the device logic.

The SEL-2431 automatically scrolls information that requires more space than provided by a 20-character LCD line. Use the **Left Arrow** and **Right Arrow** pushbuttons to suspend automatic scrolling and enable manual scrolling of this information.

SEL-2431 Menu Structure

Menus and displays are available for most SEL-2431 functions. From the Main menu, you can navigate to one of the following specific menus:

- Meter
- Events
- Tap Counters
- Targets
- Control
- Set/Show
- Status
- Quit

For a detailed layout of the menu structure, refer to the menu navigation card included with the SEL-2431.

Operator Control Pushbuttons

The operator control pushbuttons allow you to directly access common metering and settings portions of the LCD and navigation tree. The operator control pushbuttons reduce the number of navigation pushbuttons you need to press to get to commonly used metering and setting functions. Continue to press a given operator control pushbutton to scroll through corresponding information (see *Figure 3.8*).

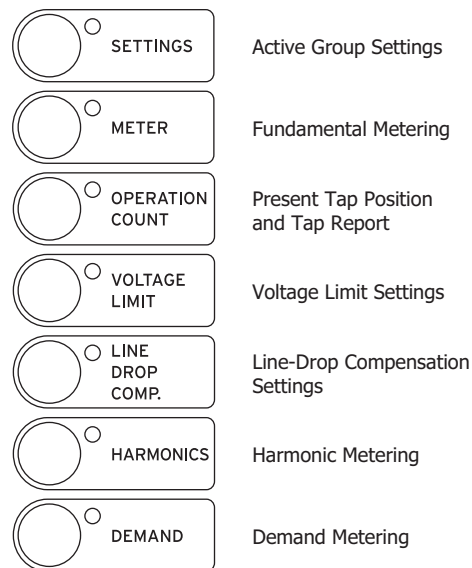

Figure 3.8 Operator Control Pushbuttons

For any of the settings-related operator controls, the ENT navigation pushbutton is used to select the displayed setting for editing (then the rest of the navigation pushbuttons are employed as in a standard front-panel setting procedure—see *Table 3.4*).

To change the function of these operator control pushbuttons and associated LEDs, see *Front-Panel Settings for Operator Control Pushbuttons and LEDs* in *Section 10: Front-Panel Operations* in the *SEL-2431 Voltage Regulator Control Instruction Manual*.

Operation and Indication LEDs

Figure 3.9 shows the operation and indication LEDs.

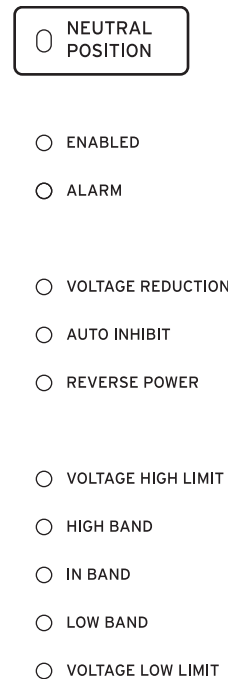

Figure 3.9 Operation and Indication LEDs

The SEL-2431 gives you an at-a-glance confirmation of control conditions via the operation and indication LEDs. These LEDs are located on the upper left side of the front panel.

See *Section 10: Front-Panel Operations* in the *SEL-2431 Voltage Regulator Control Instruction Manual* for more internal details on these indicator LEDs.

NEUTRAL POSITION LED

This LED indicates when the voltage regulator signals that it is in the neutral position. This indication comes from feedback from the voltage regulator via the neutral position switch input. See *Figure C.2* for more details on the neutral position switch LEDs. This LED is only one of the methods used to verify that the regulator is in the neutral position. A regulator should never be bypassed unless all of the indicators indicate that the regulator is in the neutral tap position.

ENABLED LED

The **ENABLED** LED is illuminated when the control supply voltage is present, the device is healthy, and processing is enabled. The **ENABLED** LED might be deasserted for:

- Self-test failure
- Firmware download
- Settings changes

If the **ENABLED LED** is not illuminated due to a self-test failure, the LCD will show the failed self-test.

ALARM LED

The **ALARM LED** is user programmable via the **ALARM SELOGIC®** front-panel equation. The LED is illuminated when the **ALARM SELOGIC** equation is asserted and the LED is not illuminated when the **ALARM SELOGIC** equation is deasserted.

The default **ALARM SELOGIC** equation is set to assert when there is a hardware alarm (diagnostic failure), a software alarm (such as gaining level 2 access at a communications port or front-panel interface) or if there are interface errors between the SEL-2431 voltage regulator control and the voltage regulator. These errors could include the tap position being incorrect or a raise or lower not being executed properly.

VOLTAGE REDUCTION LED

The **VOLTAGE REDUCTION LED** indicates when voltage reduction is in effect.

AUTO INHIBIT LED

The **AUTO INHIBIT LED** indicates when automatic tap-changing is inhibited, and is controlled by the logical OR combination of **INHIBIT** and **MANUAL**. With the factory-default Group settings (**INHIBSV := 50FLT**), the **AUTO INHIBIT LED** will illuminate when the fault detector element asserts, when the operating mode (i.e., Locked Forward) has inhibited operation because of power flow direction or magnitude, or when the controller enters **MANUAL** mode.

REVERSE POWER LED

The **REVERSE POWER LED** indicates when a reverse power condition is detected on the power system. The **REVERSE POWER LED** will illuminate regardless of the control operating mode, for example, it can illuminate in locked-forward mode if a reverse power flow is detected.

Voltage Band Indicators

The voltage band indicator LEDs: **VOLTAGE HIGH LIMIT**, **HIGH BAND**, **IN BAND**, **LOW BAND**, and **VOLTAGE LOW LIMIT** are all extinguished when the operating mode (selected by Group setting **OPMODE**) is in an inhibited operating region, for example, when reverse power is detected during locked-forward operating mode.

The voltage band indicator LEDs are also extinguished when the control is inhibited (Device Word bit **INHIBIT** is asserted).

The **VOLTAGE HIGH LIMIT** and **VOLTAGE LOW LIMIT** LEDs, based on terminal voltage, are independent of the **HIGH BAND**, **IN BAND**, and **LOW BAND** LEDs, which are based on regulated voltage. For example, when system loading is heavy and line-drop compensation is enabled, the regulated voltage may be in a low band region, yet the voltage regulator output terminal voltage is in a voltage high limit region. Both LEDs will be illuminated in this situation. The SEL-2431 gives priority to voltage limiting.

VOLTAGE HIGH LIMIT LED

The **VOLTAGE HIGH LIMIT LED** is illuminated when the system load-side voltage exceeds the voltage limit **VMAX** setting (available when Group setting **ENLIMIT := Y**) and flashes on and off every second when the system load-side voltage exceeds the high-voltage runback threshold defined by Group settings **DBNDH + VMAX** (available when **ENRUNBK := Y**).

HIGH BAND LED

The **HIGH BAND LED** is illuminated when the regulated voltage is greater than the high-band threshold, which is a function of Group settings $F_CNBND + (F_BNDWD / 2)$ for forward direction operation and $R_CNBND + (R_BNDWD / 2)$ for reverse direction operation. The threshold is decreased during voltage reduction conditions.

IN BAND LED

The **IN BAND LED** is illuminated when the regulated voltage is between the high-band threshold and low-band threshold. This indicates that the regulated voltage is within the established operating band.

LOW BAND LED

The **LOW BAND LED** is illuminated when the regulated voltage is lower than the low-band threshold, which is a function of Group settings $F_CNBND - (F_BNDWD / 2)$ for forward direction operation and $R_CNBND - (R_BNDWD / 2)$ for reverse direction operation. The threshold is decreased during voltage reduction conditions.

VOLTAGE LOW LIMIT LED

The **VOLTAGE LOW LIMIT LED** is illuminated when the system load-side voltage is less than the voltage limit **VMIN** setting (available when Group setting **ENLIMIT := Y**) and flashes on and off every second when the system load-side voltage is less than the low-voltage runback threshold defined by the Group settings $VMIN - DBNDH$ (available when **ENRUNBK := Y**).

NOTE: The five voltage band LEDs are extinguished when the voltage regulation status is inhibited. For example, when configured for Locked Forward Mode and reverse power is detected.

Setting Voltage Regulator Tap Position

To set the voltage regulator's tap position into the SEL-2431, use the front-panel interface. Use the navigation pushbuttons to navigate to the **Tap Counters** menu, then access the **Set Tap Position** menu.

You can then set the regulator's present tap position (-16 to 0, N, to +16) in the SEL-2431.

Note that you can also use the **TAP P x** command from a communications port to set the voltage regulator tap position into the SEL-2431.

Voltage Regulator Bypassing

WARNING

Carefully follow the voltage regulator bypassing procedures in the voltage regulator instruction manual, if bypassing is necessary.

Consult the voltage regulator instruction manual for the voltage regulator bypassing procedures. The following SEL-2431 Voltage Regulator Control front-panel features (see *Figure 3.1*) aid in voltage regulator bypassing, when bypassing is necessary:

- Front-panel **NEUTRAL POSITION LED**—confirm that it is illuminated
- Front-panel **CONTROL POWER** switch—set to OFF position
- Front-panel **MOTOR** fuse—can be removed (see *Figure C.1*)

Always follow industry-recognized safety procedures, and do not under any circumstance bypass a regulator unless all of the indicators agree that the voltage regulator is in neutral. The three indicators are:

1. The Neutral Position switch should be illuminated.
2. The front-panel display should indicate that Tap Position = 0 (or Neutral).
3. The dial on the voltage regulator should point to the neutral position.

This page intentionally left blank

Section 4

Basic Settings

Overview

The SEL-2431 Voltage Regulator Control stores customer-entered settings in nonvolatile memory. Settings are divided into the following settings classes:

1. Global
2. Group n (where n = Group 1–4)
3. Logic n (where n = Group 1–4)
4. Front Panel
5. Report
6. Port p (where p = F, 1, and 2 [Ports 1 and 2 are optional communications ports])
7. Distributed Network Protocol (DNP) Maps 1 and 2

Some setting classes have multiple instances. In the previous list, there are four settings groups for group and logic settings and as many as three port setting instances, one for each serial port.

Only front-panel modification of Global and Group settings will be discussed in this section. Logic, Front Panel, Report, and DNP Map settings cannot be accessed via the front panel. For more information on all settings and how to modify them using serial communications and PC software refer to *Section 2: PC Software, Section 8: Settings*, and *Appendix D: DNP3 Communications* of the *SEL-2431 Voltage Regulator Control Instruction Manual*.

Make Global Settings (SET G) First

For most applications, make Global settings before making the group setting entries. Changes to Global settings may cause other settings to be hidden from view or changed to default values.

The Global settings, in general, define the overall physical connections, equipment type, and system voltage levels, and normally will not need to be changed once initially configured for a specific voltage regulator installation.

For basic voltage regulator retrofit applications, the Logic, Front Panel, and Report settings classes may be left at the factory-default values. Changes are only required to these classes when advanced control, indication, or reporting functions are required.

View/Change Settings Using the Front Panel

You can use the pushbuttons on the front panel to view/change settings. *Section 3: Front-Panel Interface* presents the operating details of the front panel. Enter the front-panel menu by pushing the **ESC** pushbutton. It will display the following message:



Scroll down the menu by using the **Down Arrow** pushbutton until the display shows the following message:

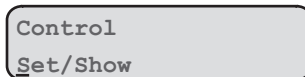

The cursor (underline) should be on *Set/Show*. Enter the *Set/Show* menu by pushing the **Enter** pushbutton. The display shows the following message:

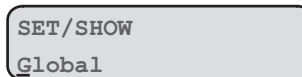

Scroll down the menu to underline the desired settings class: Global, Group, or Port. Select the underlined settings class with the **ENT** pushbutton, and the device will present you with the settings as listed in the SEL-2431 settings sheets. Use the **Up Arrow**, **Down Arrow**, **Left Arrow**, and **Right Arrow** pushbuttons to scroll through the settings and view/change them according to your needs by selecting and editing them. After viewing/changing the settings, press the **ESC** pushbutton until the following message appears:

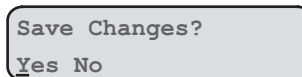

Select and enter the appropriate command by pushing the **Enter** pushbutton. Select **Yes** to save the settings changes and **No** to discard the changes.

Settings Explanations

Enable Settings

Enable settings are available in Global and Group settings. Enable settings can cause other settings to be available or hidden, which reduces the number of settings to be made in most applications. Settings that are controlled by enable settings are indicated on the setting sheets. Some of these enable settings directly affect the SEL-2431 built-in logic. *Table 4.1* lists the enable settings.

Table 4.1 Use of Enable Settings (Sheet 1 of 2)

Enable Setting	Controls
EGADVS	Global settings for Data Reset, Group Selection, Time-of-Day Operation, and Time and Date Management.
ELDC	Group settings VLDCFWR, VLDCFWX, VLDCRVR, VLDCRVX
E50L	Group settings 50L1P through 50L7P
ENREDUC	Group settings VREDMOD through SETLDC0

Table 4.1 Use of Enable Settings (Sheet 2 of 2)

Enable Setting	Controls
ENLIMIT	Group settings VMAX and VMIN
ENRUNBK	Group settings RBKBLSV, RUNBKPU, DBNDH, DBNDL

Basic Global Settings

General Global Settings

Setting Name	Settings Description	Default	Range	Increment
NFREQ	Nominal Frequency	60 Hz	50 Hz, 60 Hz	

The Global Setting NFREQ allows you to configure the SEL-2431 to your specific system. Set NFREQ equal to your nominal power system frequency, either 50 Hz or 60 Hz.

Setting Name	Settings Description	Default	Range	Increment
DATE_F	Date Format	MDY	MDY, YMD	

Set DATE_F to format the date displayed in voltage regulator control reports and the front-panel display. Set DATE_F to MDY to display dates in Month/Day/Year format; set DATE_F to YMD to display dates in Year/Month/Day format; set DATE_F to DMY to display dates in Day/Month/Year format.

Setting Name	Settings Description	Default	Range	Increment
EGADVS	Enable Global Advanced Settings	N	Y, N	

The factory-default setting EGADVS := N hides several Global settings categories that are not used in every application. Settings available when EGADVS := Y (Data Reset, Group Selection, Time-of-Day Operation, Time and Date Management), are not discussed in this section.

Regulator Nameplate Data

Most of the information needed for this category can be found on the voltage regulator nameplate or in the accompanying regulator manual.

Setting Name	Settings Description	Default	Range	Increment
KV	Regulator Rated Voltage	7.20	0.10–40.00 kV	0.01

E/E₁Y designates a winding that may be delta-connected for operation on an E volt system or may be wye-connected for operation on an E₁ volt system.^a In either case, make setting KV in accordance with the voltage regulator nameplate value E (in kV), typically shown as:

RATED VOLTAGE 7620/13200Y

In this example, make setting KV := 7.62. Use the rated voltage (above) even when the voltage regulator has nameplate voltage selections indicated by a pin or embossed mark.

^a IEEE Std C57.12.00-2021, IEEE Standard for General Requirements for Liquid-Immersed Distribution, Power, and Regulating Transformers, clause 5.12.3 Schematic representation, Table 7, Identification (1)(b).

Setting Name	Settings Description	Default	Range	Increment
CTPOL	CT Winding Polarity	NORM	NORM, REV	

The CTPOL setting selects the normal (NORM) or reverse (REV) polarity of the IL current connection. See *Voltage and Current Polarity Reversal on page B.10*.

4.4 Basic Settings
Basic Global Settings

Setting Name	Settings Description	Default	Range	Increment
CTPRIM	CT Primary Current	250	25–3600 A	1

SET CTPRIM to the voltage regulator primary current transformer nominal rating, in primary amperes. On some voltage regulators, the CT Primary rating may differ from the voltage regulator nameplate current capacity at a given voltage.

Setting Name	Settings Description	Default	Range	Increment
TAPCHNGR	Tap Changer Type	SIEMENS	GE, COOPER, SIEMENS, HOWARD	

Set TAPCHNGR to the voltage regulator tap changer manufacturer. Choose from GE, COOPER, SIEMENS, or HOWARD. For Toshiba CR-3, ITB RAV-2, or Romagnole SVR regulators, choose the GE setting.

Setting Name	Settings Description	Default	Range	Increment
TYPE	Regulator Type	B	A, B	

Set TYPE to match the voltage regulator (see *Figure B.1* through *Figure B.4*).

Setting Name	Settings Description	Default	Range	Increment
PT1POL ^a	PT1 Winding Polarity	NORM	NORM, REV	

The PT1POL setting selects normal (NORM) or reverse (REV) polarity of the V_{S1} voltage connection. See *Voltage and Current Polarity Reversal* on page B.10.

^a This setting corresponds to the voltage on the following interface terminals: U2-E (Siemens, Figure B.12 and Figure B.13), MS-G (Howard, Figure B.12 and Figure B.13), VM-G (Cooper, Figure B.6), NN20, NN21, or NN21-NN10 (GE Traditional, Figure B.7), 22-20 (GE Power Disconnect, Figure B.8), 11-1 (Toshiba CR-3, Figure B.9), T, S, or F-A (ITB RAV-2, Figure B.10), and 5-1 (Romagnole SVR, Figure B.11).

Setting Name	Settings Description	Default	Range	Increment
PT1PRIM ^a	PT1 Primary Voltage	7.20	0.10–40.00 kV	

Enter the primary winding rating for the V_{S1} source, in kV. See *Understand Voltage Sources and Settings Correspondence Before Making Connections* on page B.1.

^a This setting corresponds to the voltage on the following interface terminals: U2-E (Siemens, Figure B.12 and Figure B.13), MS-G (Howard, Figure B.12 and Figure B.13), VM-G (Cooper, Figure B.6), NN20, NN21, or NN21-NN10 (GE Traditional, Figure B.7), 22-20 (GE Power Disconnect, Figure B.8), 11-1 (Toshiba CR-3, Figure B.9), and T, S, or F-A (ITB RAV-2, Figure B.10), and 5-1 (Romagnole SVR, Figure B.11).

Setting Name	Settings Description	Default	Range	Increment
PT1SEC ^a	PT1 Secondary Voltage	120.0	80.0–145.0 V	0.1

Enter the secondary winding rating for the V_{S1} source, in V. If there is a ratio correction transformer present in the V_{S1} circuit, see *Appendix E: Voltage Base and Ratio Correction Transformer*.

^a This setting corresponds to the voltage on the following interface terminals: U2-E (Siemens, Figure B.12 and Figure B.13), MS-G (Howard, Figure B.12 and Figure B.13), VM-G (Cooper, Figure B.6), NN20, NN21, or NN21-NN10 (GE Traditional, Figure B.7), 22-20 (GE Power Disconnect, Figure B.8), 11-1 (Toshiba CR-3, Figure B.9), and T, S, or F-A (ITB RAV-2, Figure B.10), and 5-1 (Romagnole SVR, Figure B.11).

Setting Name	Settings Description	Default	Range	Increment
2ND_PT	Second PT Connected	N	Y, N	

The 2ND_PT setting is not displayed when TAPCHNGR := HOWARD and TYPE := A. See *Understand Voltage Sources and Settings Correspondence Before Making Connections* on page B.1.

Setting Name	Settings Description	Default	Range	Increment
PT2POL	PT2 Winding Polarity	NORM	NORM, REV	

The PT2POL setting selects normal (NORM) or reverse (REV) polarity of the V_{S2} voltage connections. See *Voltage and Current Polarity Reversal* on page B.10.

Setting Name	Settings Description	Default	Range	Increment
PT2PRIM ^a	PT2 Primary Voltage	7.20	0.10–40.00 kV	0.01

Setting Name	Settings Description	Default	Range	Increment
<p>Setting PT2PRIM is only displayed when a second PT is connected. Enter the primary winding rating for the V_{S2} source, in kV. See <i>Understand Voltage Sources and Settings Correspondence Before Making Connections on page B.1.</i></p>				
Setting Name	Settings Description	Default	Range	Increment
PT2SEC ^a	PT2 Secondary Voltage	120	80.0–145.0 V	0.1
<p>Setting PT2SEC is only displayed when a second PT is connected. Enter the secondary winding rating for the V_{S2} source, in V. If there is a ratio correction transformer present in the V_{S2} circuit, see <i>Appendix E: Voltage Base and Ratio Correction Transformer.</i></p>				

^a This setting corresponds to the voltage on the following interface terminals: P2-E (Siemens, Figure B.12 and Figure B.13), PS-G (Howard, Figure B.12 and Figure B.13), V7-G (Cooper, Figure B.6).

Connection Data

Setting Name	Settings Description	Default	Range	Increment
BASE_PRI	Base Primary Voltage	7.20	0.10–40.00 kV	0.01
<p>Enter the nominal system primary voltage in kV. This value typically matches the rating of the single-phase distribution transformers used on the regulated line. This setting allows the voltage control set points in the SEL-2431 to be made on the customer service voltage base (typically 120 V in North America), rather than on the actual voltage regulator secondary base. See <i>Appendix E: Voltage Base and Ratio Correction Transformer.</i></p>				

Setting Name	Settings Description	Default	Range	Increment
BASE_SEC	Base Secondary Voltage	120.0	80.0–145.0 V	0.1
<p>Enter the nominal system secondary voltage in V. This value typically matches the rating of the single-phase distribution transformers used on the regulated line. See the preceding explanation for setting BASE_PRI. See <i>Appendix E: Voltage Base and Ratio Correction Transformer.</i></p>				

Setting Name	Settings Description	Default	Range	Increment
CONFIG	Regulator Configuration	WYE	WYE, DLAG, DLEAD, SHIFT	

For phase-neutral voltage regulator installations, set CONFIG := WYE.

For phase-to-phase voltage regulator installations, set CONFIG := DLAG or DLEAD, depending on the physical connection of the particular regulator. See *Determine Lead and Lag Units in Open-Delta or Closed-Delta Voltage Regulator Installations on page 4.15*.

For phase-neutral voltage regulators or Load Tap Changer (LTC) applications where there is a phase shift of the load current IL with respect to the load voltage VL, set CONFIG := SHIFT. See Regulator Configuration (CONFIG), DELTA, D_LAG, D_LEAD, and SHIFT in Section 8: Settings in the *SEL-2431 Voltage Regulator Control Instruction Manual*.

Setting Name	Settings Description	Default	Range	Increment
DELTA	Delta Power Type	CLOSED	OPEN, CLOSED	

Setting made when CONFIG := DLAG or DLEAD. It determines metering quantities for open-delta or closed-delta installations.

Setting Name	Settings Description	Default	Range	Increment
D_LAG	Angle by Which I Lags V	30	0–360 degrees	1

Setting made when CONFIG := DLAG. The default setting of 30 degrees is correct for standard delta (lagging) installations. The SEL-2431 uses D_LAG to shift the measured IL current phase relative to voltage VL.

Setting Name	Settings Description	Default	Range	Increment
D_LEAD	Angle by Which I Leads V	30	0–360 degrees	1

Setting made when CONFIG := DLEAD. The default setting of 30 degrees is correct for all standard delta (leading) installations. The SEL-2431 uses D_LEAD to shift the measured IL current phase relative to voltage VL.

Setting Name	Settings Description	Default	Range	Increment
ISHIFT	Angle by Which I Lags V	0	0–360 degrees	1

When CONFIG := SHIFT, set ISHIFT to the angle by which the load current IL lags the load voltage VL.

Basic Group Settings

Setting Name	Settings Description	Default	Range	Increment
DID	Device Identification	SEL-2431	(16 characters [0–9, A–Z, -, /, ., space])	

The Device Identifier is typically used to identify the voltage regulator control or the type of regulation scheme.

Setting Name	Settings Description	Default	Range	Increment
TID	Terminal Identification	Voltage Reg.	(16 characters [0–9, A–Z, -, /, ., space])	

A typical Terminal Identifier includes an abbreviation of the substation name, line terminal, power system phase, or physical location.

Setting Name	Settings Description	Default	Range	Increment
OPMODE	Operating Mode	LOCKFWD	LOCKFWD, LOCKREV, IDLEREV, BIDIR, COGEN, FLEXDG	

Set OPMODE to the desired voltage regulation mode. LOCKFWD = Locked Forward, LOCKREV = Locked Reverse, IDLEREV = Idle Reverse, BIDIR = Bidirectional, COGEN = Cogeneration, FLEXDG = Flexible Distributed Generation

Setting Name	Settings Description	Default	Range	Increment
BIASMODE	Voltage Regulation Bias Mode	OFF	OFF, FWD, REV	

BIASMODE is available only for OPMODE := BIDIR, COGEN, or FLEXDGD. See the *SEL-2431 Voltage Regulator Control Instruction Manual* for more information.

Setting Name	Settings Description	Default	Range	Increment
FLEX_50	FLEXDGD Operating Mode Current Override	OFF	OFF, FWD, REV	

FLEX_50 is available only for OPMODE := FLEXDGD. See the *SEL-2431 Voltage Regulator Control Instruction Manual* for more information.

Setting Name	Settings Description	Default	Range	Increment
TAPDELTL	Low Tap Delta Voltage Threshold Per Unit	0.50	0.25–0.90	0.01

TAPDELTL is available only for OPMODE := FLEXDGD. See the *SEL-2431 Voltage Regulator Control Instruction Manual* for more information.

Setting Name	Settings Description	Default	Range	Increment
TAPDELTH	High Tap Delta Voltage Threshold Per Unit	0.60	0.25–0.90	0.01

TAPDELTH is available only for OPMODE := FLEXDGD. See the *SEL-2431 Voltage Regulator Control Instruction Manual* for more information.

Setting Name	Settings Description	Default	Range	Increment
TAPMAX	Maximum Software Tap Number	OFF	OFF, 8 to 16	1

Set TAPMAX to the maximum desired tap position for the application.

When configuring settings for a Romannole SVR, set TAPMAX := 16 to prevent the regulator from attempting to tap beyond mechanical limits.

Setting Name	Settings Description	Default	Range	Increment
TAPMIN	Minimum Software Tap Number	OFF	OFF, –8 to –16	1

Set TAPMIN to the minimum desired tap position for the application.

When configuring settings for a Romannole SVR, set TAPMIN := –16 to prevent the regulator from attempting to tap beyond mechanical limits.

Setting Name	Settings Description	Default	Range	Increment
TD2	Time Delay 2 for Subsequent Taps	10.0	1.0 ^a to 999.0	0.1

After the initial tap is issued, if the voltage continues to stay “out of band,” TD2 qualifies subsequent tap change operations.

^a The lower limit for group setting TD2 will be 1.3 + Global setting NEUTOVR seconds when Global setting TAPCHNGR is set to SIEMENS. Otherwise the lower limit of TD2 is 1.0 seconds. NEUTOVR is an Advanced Regulator Nameplate setting, see Advanced Regulator Nameplate Data in Section 8: Settings in the *SEL-2431 Voltage Regulator Control Instruction Manual* for a detailed description.

Forward Controller Settings

Make the following settings when OPMODE ≠ LOCKREV.

Setting Name	Settings Description	Default	Range	Increment
F_CHAR	Forward Reset Characteristics	DISC	FAST, DISC, DELAY, DLY_FRZ	

Select the desired reset characteristic for reset timer F_TD1. For more information on the different reset characteristics, see *Appendix G: Definite Time Characteristics* in the *SEL-2431 Voltage Regulator Control Instruction Manual*.

Setting Name	Settings Description	Default	Range	Increment
F_CNBND	Forward Center Band	120.0	96.0–144.0 V sec	0.1

Set F_CNBND to the desired forward voltage regulation level.

Setting Name	Settings Description	Default	Range	Increment
F_BNDWD	Forward Band Width	2.0	1.0–10.0 V sec	0.1

Set F_BNDWD to the desired regulation bandwidth. Voltage bandwidth prevents continual hunting (tap operation) by the voltage regulator control.

Setting Name	Settings Description	Default	Range	Increment
F_TD1	Forward Time Delay 1 for First Tap	60.0	1.0 to 999.0 seconds	0.1

Set F_TD1 to the desired time delay for the first operation in a tap sequence.

Setting Name	Settings Description	Default	Range	Increment
F_DISC	Forward Disc-Like Reset Factor	0.60	0.10–2.00	0.01

When F_CHAR := DISC, set F_DISC to the desired reset factor.

The DISC reset characteristic is similar in behavior to the resetting of a traditional induction disc relay. When the regulated voltage drops back “in band,” the first-tap timer starts resetting at the rate of F_DISC seconds for every second of elapsed time.

Setting Name	Settings Description	Default	Range	Increment
F_DLYRS	Forward Delay on Reset	0.0	0.0 to 999.0 seconds	0.1

When F_CHAR := DELAY or DLY_FRZ, set F_DLYRS to the desired reset delay.

When F_CHAR is set to DELAY or DLY_FRZ, timer setting F_DLYRS keeps the F_TD1 timer from resetting if the voltage makes an excursion back “in band” for less than F_DLYRS time.

Reverse Controller Settings

Make the following settings when OPMODE := LOCKREV, BIDIR, or FLEXDG.

Setting Name	Settings Description	Default	Range	Increment
R_CHAR	Reverse Reset Characteristic	DISC	FAST, DISC, DELAY, DLY_FRZ	

Select the desired reset characteristic for reset timer R_TD1. For more information on the different reset characteristics, see *Appendix G: Definite Time Characteristics* in the *SEL-2431 Voltage Regulator Control Instruction Manual*.

Setting Name	Settings Description	Default	Range	Increment
R_CNBND	Reverse Center Band	120.0	96.0–144.0 V sec	0.1

Set R_CNBND to the desired reverse voltage regulation level.

Setting Name	Settings Description	Default	Range	Increment
R_BNDWD	Reverse Band Width	2.0	1.0–10.0 V sec	0.1

Set R_BNDWD to the desired regulation bandwidth. Voltage bandwidth prevents continual hunting (tap operation) by the voltage regulator control.

Setting Name	Settings Description	Default	Range	Increment
R_TD1	Reverse Time Delay 1 for First Tap	60.0	1.0 to 999.0 seconds	0.1

Set R_TD1 to the desired time delay for the first operation in a tap sequence.

Setting Name	Settings Description	Default	Range	Increment
R_DISC	Reverse Disc-Like Reset Factor	0.60	0.10–2.00	0.01

When R_CHAR := DISC, set R_DISC to the desired reset factor.

The DISC reset characteristic is similar in behavior to the resetting of a traditional induction disc relay. When the regulated voltage drops back “in band,” the first-tap timer starts resetting at the rate of R_DISC seconds for every second of elapsed time.

Setting Name	Settings Description	Default	Range	Increment
R_DLYRS	Reverse Delay on Reset	0.0	0.0 to 999.0 seconds	0.1

When R_CHAR := DELAY or DLY_FRZ, set R_DLYRS to the desired reset delay.

When R_CHAR is set to DELAY or DLY_FRZ, timer setting R_DLYRS keeps the R_TD1 timer from resetting if the voltage makes an excursion back “in band” for less than R_DLYRS time.

Line-Drop Compensation Settings

Setting Name	Settings Description	Default	Range	Increment
ELDC	Enable Line Drop Compensation	N	Y, N (if OPMODE ≠ FLEXDG) Y1, Y2, Y3, Y4, N (if OPMODE := FLEXDG)	

Yes settings options Y1, Y2, Y3, and Y4 are available only for OPMODE := FLEXDG. See the *SEL-2431 Voltage Regulator Control Instruction Manual* for more information.

Setting Name	Settings Description	Default	Range	Increment
VLDCFWR	Forward Resistive LDC Voltage	0.0	–24.0 to +24.0 V sec	0.1

Set VLDCFWR to the Forward Resistive LDC Voltage.

Setting Name	Settings Description	Default	Range	Increment
VLDCFWX	Forward Reactive LDC Voltage	0.0	–24.0 to +24.0 V sec	0.1

Set VLDCFWX to the Forward Reactive LDC Voltage.

Setting Name	Settings Description	Default	Range	Increment
VLDCRVR	Reverse Resistive LDC Voltage	0.0	–24.0 to +24.0 V sec	0.1

Set VLDCRVR to the Reverse Resistive LDC Voltage.

Setting Name	Settings Description	Default	Range	Increment
VLDCRVX	Reverse Reactive LDC Voltage	0.0	–24.0 to +24.0 V sec	0.1

Set VLDCRVX to the Reverse Reactive LDC Voltage.

Setting Name	Settings Description	Default	Range	Increment
Setting Name	Settings Description	Default	Range	Increment
VLDCFVMP	Forward LDC Voltage positive maximum	OFF	OFF, +0.1 to +24.0	0.1
Limits the positive influence of LDC when power flow is in the forward direction. Positive LDC is the traditional application of LDC.				
Setting Name	Settings Description	Default	Range	Increment
VLDCFWMN	Forward LDC Voltage negative maximum	OFF	OFF, -0.1 to -24.0	0.1
Limits the negative influence of LDC when power flow is in the forward direction. Negative LDC is sometimes used in advanced applications of LDC.				
Setting Name	Settings Description	Default	Range	Increment
VLDCFVMP	Reverse LDC Voltage positive maximum	OFF	OFF, +0.1 to +24.0	0.1
Limits the positive influence of LDC when power flow is in the reverse direction. Positive LDC is the traditional application of LDC.				
Setting Name	Settings Description	Default	Range	Increment
VLDCFVMN	Reverse LDC Voltage negative maximum	OFF	OFF, -0.1 to -24.0	0.1
Limits the negative influence of LDC when power flow is in the reverse direction. Negative LDC is sometimes used in advanced applications of LDC.				

Overcurrent Settings

Setting Name	Settings Description	Default	Range	Increment
E50L	Load Overcurrent Element Levels	1	N, 1-7	

Set E50L to the desired number of enabled overcurrent elements.

Setting Name	Settings Description	Default	Range	Increment
50L1P	Load Overcurrent Pickup	0.250 125%	OFF, 0.002-0.700 A sec OFF, 1%-350%	0.001 0.5% ^a
When E50L ≥ 1, set 50L1P to the desired Load Overcurrent Pickup level.				
50L2P	Load Overcurrent Pickup	OFF	OFF, 0.002-0.700 A sec OFF, 1%-350%	0.001 0.5% ^a
When E50L ≥ 2, set 50L2P to the desired Load Overcurrent Pickup level.				
50L3P	Load Overcurrent Pickup	OFF	OFF, 0.002-0.700 A sec OFF, 1%-350%	0.001 0.5% ^a
When E50L ≥ 3, set 50L3P to the desired Load Overcurrent Pickup level.				
50L4P	Load Overcurrent Pickup	OFF	OFF, 0.002-0.700 A sec OFF, 1%-350%	0.001 0.5% ^a
When E50L ≥ 4, set 50L4P to the desired Load Overcurrent Pickup level.				
50L5P	Load Overcurrent Pickup	OFF	OFF, 0.002-0.700 A sec OFF, 1%-350%	0.001 0.5% ^a

Setting Name	Settings Description	Default	Range	Increment
When E50L ≥ 5, set 50L5P to the desired Load Overcurrent Pickup level.				
Setting Name	Settings Description	Default	Range	Increment
50L6P	Load Overcurrent Pickup	OFF	OFF, 0.002–0.700 A sec OFF, 1%–350%	0.001 0.5% ^a
When E50L ≥ 6, set 50L6P to the desired Load Overcurrent Pickup level.				
Setting Name	Settings Description	Default	Range	Increment
50L7P	Load Overcurrent Pickup	OFF	OFF, 0.002–0.700 A sec OFF, 1%–350%	0.001 0.5% ^a
When E50L = 7, set 50L7P to the desired Load Overcurrent Pickup level.				

^a Alternate setting range of percentage will be activated if 50TYPE is set to “% Rated.”

Setting Name	Settings Description	Default	Range	Increment
50FLTP	Fault Overcurrent Element Pickup	0.600 300%	OFF, 0.400–2.000 A sec OFF, 200%–1000%	0.001 0.5% ^a

Set 50FLTP to the desired Fault Overcurrent Element Pickup level. 50FLTP is used to detect fault current and prevent false recording of metering data during power system disturbances. It can also be used to block or inhibit tap change operations during fault conditions.

^a Alternate setting range of percentage will be activated if 50TYPE is set to “% Rated.”

Setting Name	Settings Description	Default	Range	Increment
50FWDP	Forward I Threshold	0.002 1%	0.002–0.020 A sec 1%–10%	0.001 0.5% ^a

Set 50FWDP to the desired forward current threshold.

For example, the Locked Reverse Mode (OPMODE := LOCKREV) will be inhibited when the current is in the FORWARD direction and more than the group setting 50FWDP.

^a Alternate setting range of percentage will be activated if 50TYPE is set to “% Rated.”

Setting Name	Settings Description	Default	Range	Increment
50REVP	Reverse I Threshold	0.002 1%	0.002–0.020 A sec 1%–10%	0.001 0.5% ^a

Set 50REVP to the desired reverse current threshold.

For example, the Locked Forward Mode (OPMODE := LOCKFWD) will be inhibited when the current is in the REVERSE direction and more than the group setting 50REVP.

^a Alternate setting range of percentage will be activated if 50TYPE is set to “% Rated.”

Voltage Reduction Settings

Setting Name	Settings Description	Default	Range	Increment
ENREDUC	Enable Voltage Reduction	N	Y, N	

SET ENREDUC = Y to enable the voltage reduction features of the SEL-2431.

Voltage reduction is the deliberate lowering of the system voltage when the power demand exceeds the supply. This reduction in voltage is achieved by lowering the existing center band setting by a predefined percentage. For a detailed explanation of voltage reduction and its associated modes and settings refer to *Section 4: Control Operating Modes* in the *SEL-2431 Voltage Regulator Control Instruction Manual*.

Setting Name	Settings Description	Default	Range	Increment
VREDMOD	Voltage Reduction Mode	CONTROL	PULSE, LATCH, CONTROL	

Set VREDMOD to the desired Voltage Reduction Mode

Setting Name	Settings Description	Default	Range	Increment
Setting Name	Settings Description	Default	Range	Increment
VREDFP1	Forward Voltage Reduction Stage 1	2	OFF, 0.1–10	0.1
Set VREDFP1 to the desired percentage of voltage reduction for Forward Voltage Reduction Stage 1.				
Setting Name	Settings Description	Default	Range	Increment
VREDFP2	Forward Voltage Reduction Stage 2	4	OFF, 0.1–10	0.1
Set VREDFP2 to the desired percentage of voltage reduction for Forward Voltage Reduction Stage 2 when VREDFP1 ≠ OFF.				
Setting Name	Settings Description	Default	Range	Increment
VREDFP3	Forward Voltage Reduction Stage 3	6	OFF, 0.1–10.0	0.1
Set VREDFP3 to the desired percentage of voltage reduction for Forward Voltage Reduction Stage 3 when VREDFP1 ≠ OFF and VREDFP2 ≠ OFF.				
Setting Name	Settings Description	Default	Range	Increment
VREDRP1	Reverse Voltage Reduction Stage 1	2	OFF, 0.1–10.0	0.1
Set VREDRP1 to the desired percentage of voltage reduction for Reverse Voltage Reduction Stage 1.				
Setting Name	Settings Description	Default	Range	Increment
VREDRP2	Reverse Voltage Reduction Stage 2	4	OFF, 0.1–10.0	0.1
Set VREDRP2 to the desired percentage of voltage reduction for Reverse Voltage Reduction Stage 2 when VREDRP1 ≠ OFF.				
Setting Name	Settings Description	Default	Range	Increment
VREDRP3	Reverse Voltage Reduction Stage 3	6	OFF, 0.1–10.0	0.1
Set VREDRP3 to the desired percentage of voltage reduction for Reverse Voltage Reduction Stage 3 when VREDRP1 ≠ OFF and VREDRP2 ≠ OFF.				
Setting Name	Settings Description	Default	Range	Increment
VRSPU1	VR Stage 1 Timer Pickup	30	0.0–9999.0 seconds	0.1
When VREDMOD ≠ PULSE, set VRSPU1 to the desired pickup delay for Voltage Reduction Stage 1.				
Setting Name	Settings Description	Default	Range	Increment
VRSPU2	VR Stage 2 Timer Pickup	60	0.0–9999.0 seconds	0.1
When VREDMOD ≠ PULSE, set VRSPU2 to the desired pickup delay for Voltage Reduction Stage 2.				
Setting Name	Settings Description	Default	Range	Increment
VRSPU3	VR Stage 3 Timer Pickup	90	0.0–9999.0 seconds	0.1
When VREDMOD ≠ PULSE, set VRSPU3 to the desired pickup delay for Voltage Reduction Stage 3.				
Setting Name	Settings Description	Default	Range	Increment
VRED1SV	Voltage Reduction Inputs	NA	(SELOGIC®)	
When VREDMOD := CONTROL, enter desired conditions to activate voltage reduction stage 1 in VRED1SV. Stage 1 voltage reduction is enabled when group setting SELOGIC equation VRED1SV is asserted and VRED2SV and VRED3SV are deasserted (see Section 4: Control Operating Modes in the SEL-2431 Voltage Regulator Control Instruction Manual for LATCH and PULSE mode setting details).				

Setting Name	Settings Description	Default	Range	Increment
Setting Name	Settings Description	Default	Range	Increment
VRED2SV	Voltage Reduction Inputs	NA	(SELOGIC)	
When VREDMOD := CONTROL, enter desired conditions to activate voltage reduction stage 2 in VRED2SV. Stage 2 voltage reduction is enabled when group setting SELOGIC equation VRED2SV is asserted and VRED3SV is deasserted (see Section 4: Control Operating Modes in the SEL-2431 Voltage Regulator Control Instruction Manual for LATCH mode setting details).				
Setting Name	Settings Description	Default	Range	Increment
VRED3SV	Voltage Reduction Inputs	NA	(SELOGIC)	
When VREDMOD := CONTROL, enter desired conditions to activate voltage reduction stage 3 in VRED3SV. Stage 3 voltage reduction is enabled when group setting SELOGIC equation VRED3SV is asserted.				
Setting Name	Settings Description	Default	Range	Increment
VRRSTSV	Voltage Reduction Reset	NA	(SELOGIC)	
When VREDMOD := PULSE, enter the desired voltage reduction mode reset conditions in VRRSTSV.				
Setting Name	Settings Description	Default	Range	Increment
OVRIDSV	Voltage Reduction Over-ride	NA	(SELOGIC)	
When VREDMOD := LATCH or CONTROL, enter the desired voltage reduction override conditions in OVRIDSV.				
Setting Name	Settings Description	Default	Range	Increment
VRPULPU	Voltage Reduction Pulse Length	0.02	0.00–9.00 seconds	0.02
When VREDMOD := PULSE, set VRPULPU to the desired Voltage Reduction Pulse Length.				
Setting Name	Settings Description	Default	Range	Increment
SETLDC0	Set LDC to Zero for Voltage Reduction	Y	Y, N	
Set SETLDC0 := Y to disable line-drop compensation when voltage reduction is active.				

Voltage Limit Settings

Setting Name	Settings Description	Default	Range	Increment
ENLIMIT	Enable Min/Max Voltage Control	Y	Y, N	
Set ENLIMIT := Y to enable the voltage limiting functionality in the SEL-2431. For a detailed description of voltage limiting functionality and settings, refer to Section 3: Control Algorithms in the SEL-2431 Voltage Regulator Control Instruction Manual.				
Setting Name	Settings Description	Default	Range	Increment
VMAX	Maximum Volts	130	OFF, 108.5–145.0 V sec	0.1
Set VMAX to the maximum desired voltage level for voltage limiting.				
Setting Name	Settings Description	Default	Range	Increment
VMIN	Minimum Volts	110	OFF, 80.0–131.5 V sec	0.1
Set VMIN to the minimum desired voltage level for voltage limiting.				

Runback Settings

Setting Name	Settings Description	Default	Range	Increment
ENRUNBK	Enable Runback	N	Y, N	

Make setting ENRUNBK when setting ENLIMIT := Y. Set ENRUNBK := Y to enable the runback functionality in the SEL-2431. For a detailed description of runback functionality and settings, refer to *Section 3: Control Algorithms* in the *SEL-2431 Voltage Regulator Control Instruction Manual*.

Setting Name	Settings Description	Default	Range	Increment
RBKBSLV	Runback Block	50FLT	(SELOGIC)	

Enter desired conditions for blocking runback in RBKBSLV.

Setting Name	Settings Description	Default	Range	Increment
RUNBKPU	Runback Pickup Timer	0.5	0.0 to 9999.0 seconds	0.1

Set RUNBKPU to the desired Runback Timer Pickup delay.

Setting Name	Settings Description	Default	Range	Increment
DBNDH	Deadband (High)	OFF	OFF, 0.0–6.0 V sec	0.1

When VMAX ≠ OFF, set DBNDH to the desired deadband.

Setting Name	Settings Description	Default	Range	Increment
DBNDL	Deadband (Low)	OFF	OFF, 0.0–6.0 V sec	0.1

When VMIN ≠ OFF, set DBNDL to the desired deadband.

Raise/Lower Settings

Setting Name	Settings Description	Default	Range	Increment
INHIBSV	Inhibit Conditions	50FLT	(SELOGIC)	

Enter any desired conditions for inhibiting automatic voltage regulation in INHIBSV. If voltage is out-of-band and INHIBSV asserts (= logical 1; no tapping) then deasserts (= logical 0; tapping allowed), timing to tap starts over from the beginning.

Setting Name	Settings Description	Default	Range	Increment
BLOCKSV	Block Tap Operations	50L1 OR SV02T # LOAD CURRENT LIMIT OR LOW SYSTEM VOLTAGE CONDITIONS	(SELOGIC)	

Enter any desired conditions for blocking tap operations in BLOCKSV. If voltage is out-of-band and BLOCKSV asserts (= logical 1; no tapping), timing to tap continues with the present timer, but no tapping occurs when the timer times out (a “pending tap” condition exists). Then, if the voltage is still out-of-band when BLOCKSV deasserts (= logical 0; tapping allowed), a tap occurs immediately for this “pending tap” condition.

Setting Name	Settings Description	Default	Range	Increment
RAISESV	Raise Command	TOOLOW AND AUTO # TAP POSITION IS LOWER THAN SETTING TAPMIN	(SELOGIC)	

Enter any desired conditions for a raise tap operation in RAISESV.

Determine Lead and Lag Units in Open-Delta or Closed-Delta Voltage Regulator Installations

Setting Name	Settings Description	Default	Range	Increment
LOWERSV	Lower Command	TOOHIGH AND AUTO # TAP POSITION IS HIGHER THAN SETTING TAPMAX	(SELOGIC)	

Enter any desired conditions for a lower tap operation in LOWERSV.

Demand Meter Settings

Setting Name	Settings Description	Default	Range	Increment
DMTC	Demand Meter Time Constant	15	5, 10, 15, 30, 60 minutes	

Set DMTC to the desired Demand Meter Time Constant.

Determine Lead and Lag Units in Open-Delta or Closed-Delta Voltage Regulator Installations

In open-delta or closed-delta voltage regulator installations, current leads or lags the voltage by 30 degrees for each individual single-phase voltage regulator. Global settings CONFIG, DELTA, D_LAG, and D_LEAD compensate for this 30 degrees lead or lag.

In an open-delta voltage regulator installation, one of the voltage regulators is the lag regulator and the other the lead regulator. Determine this by checking the metering and comparing angles of I_L and V_L . Perform the following steps:

- Step 1. Check that the feeder is operating close to unity power factor, with power flow in the forward direction.

This power factor and power flow knowledge comes from general system knowledge, not from SEL-2431 metering (as the SEL-2431 is not fully set up at this point).
- Step 2. Put the SEL-2431 in the manual mode (**MANUAL LED** illuminated).
- Step 3. Set Global setting CONFIG := WYE (so that there is no compensation for 30 degrees lead or lag).
- Step 4. Check metering. If I_L lags V_L by about 30 degrees, the voltage regulator is the lag regulator. If I_L leads V_L by about 30 degrees, the voltage regulator is the lead regulator.
- Step 5. Set the lag regulator to Global settings CONFIG := DLAG, DELTA := OPEN, D_LAG := 30.
- Step 6. Set the lead regulator to Global settings CONFIG := DLEAD, DELTA := OPEN, D_LEAD := 30.
- Step 7. Return the SEL-2431 to the automatic mode (**AUTO LED** illuminated), if desired.

In a closed-delta voltage regulator installation, all three of the voltage regulators are either lag regulators or lead regulators. Determine this by the same means as the preceding instructions for open-delta voltage regulator installations, though in *Step 5* and *Step 6* make Global setting DELTA := CLOSED instead.

This page intentionally left blank

Section 5

Testing and Troubleshooting

Overview

This section contains guidelines for determining and establishing test routines for the SEL-2431 Voltage Regulator Control. Follow the standard practices of your company in choosing testing philosophies, methods, and tools. The voltage regulator control incorporates self-tests to help you diagnose potential difficulties should these occur. *Voltage Regulator Control Troubleshooting on page 5.8* contains a quick-reference table for common voltage regulator control operation problems.

NOTE: The SEL-2431 is factory calibrated. If you suspect that the voltage regulator control is out of calibration, contact the factory.

Topics, tests, and troubleshooting procedures presented in this section include the following:

- Testing philosophy
- Testing methods and tools
- Self-tests
- Voltage regulator control troubleshooting
- Voltage regulator control calibration
- Technical support

The SEL-2431 is factory-calibrated; this section contains no calibration information. If you suspect that the voltage regulator control is out of calibration, contact your Technical Service Center or the SEL factory.

Testing Philosophy

Voltage regulator control testing may be divided into three categories: acceptance, commissioning, and maintenance testing. The categories are differentiated by when they take place in the life cycle of the voltage regulator control as well as by the test complexity.

The following paragraphs describe when to perform each type of test, the goals of testing at that time, and the voltage regulator control functions that you need to test at each point. This information is intended as a guideline for testing SEL voltage regulator controls.

Acceptance Testing

When: Qualifying a voltage regulator control model to be used on the utility system.

Commissioning Testing

Goals:

1. Ensure that the voltage regulator control meets published critical performance specifications such as operating speed and element accuracy.
2. Ensure that the voltage regulator control meets the requirements of the intended application.
3. Gain familiarity with voltage regulator control settings and capabilities.

What to test: All elements and logic functions critical to the intended application.

SEL performs detailed acceptance testing on all new voltage regulator control models and versions. We are certain that the voltage regulator controls we ship meet their published specifications. It is important to perform acceptance testing on a voltage regulator control if you are unfamiliar with its operating theory, scheme logic, or settings. This helps ensure the accuracy and correctness of the voltage regulator control settings when you issue them.

When: Installing a new voltage regulator control system.

Goals:

1. Ensure that all system ac and dc connections are correct.
2. Ensure that the voltage regulator control functions as intended using your settings.
3. Ensure that all auxiliary equipment operates as intended.

What to test:

- All connected or monitored inputs and outputs
- Polarity of ac connections
- Simple check of elements

SEL performs a complete functional check and calibration of each voltage regulator control before it is shipped. This helps ensure that you receive a voltage regulator control that operates correctly and accurately.

Commissioning tests should verify that the voltage regulator control is properly connected to the power system and all auxiliary equipment. Verify control signal inputs and outputs. Check SCADA control inputs and monitoring outputs. Use an ac connection check to verify that the voltage regulator control current and voltage inputs are of the proper magnitude and polarity.

Brief voltage tests ensure that the voltage regulator control settings are correct. It is not necessary to test every voltage regulator control element, timer, and function in these tests.

At commissioning time:

1. Use the voltage regulator control **METER** command to verify the ac current and voltage magnitude and polarity.
2. Use the **PULSE** command to verify voltage regulator control output contact operation.
3. Use the **TARGET** command to verify optoisolated input operation.
4. Use the **RAISE** and **LOWER** commands to verify the proper operation of the voltage regulator tap mechanism.

Maintenance Testing

When: At regularly scheduled intervals or when there is an indication of a problem with the voltage regulator control or system.

Goals:

1. Ensure that the voltage regulator control is measuring ac quantities accurately.
2. Ensure that scheme logic and elements are functioning correctly.
3. Ensure that auxiliary equipment is functioning correctly.

What to test: Anything not shown to have operated during the past maintenance interval.

SEL voltage regulator controls use extensive self-testing capabilities and feature detailed metering, event reporting, and Sequential Event Recorder (SER) functions that lower the dependence on routine maintenance testing.

1. Use the SEL voltage regulator control reporting functions as maintenance tools.

Periodically verify that the voltage regulator control is making correct and accurate current and voltage measurements by comparing the voltage regulator control Meter output to other meter readings on that line.

2. Review voltage regulator control event reports and SER in detail.

Using the event report current, voltage, and voltage regulator control element data, you can determine that the voltage regulator control elements are operating properly. Even motor raise and lower (and hold, for Cooper) currents can be observed.

3. At the end of your maintenance interval, the only items that need testing are those that have not operated during the maintenance interval.

The basis of this testing philosophy is simple: If the voltage regulator control is correctly set and connected, is measuring properly, and no self-test has failed, there is no reason to test it further.

Use event report and SER data to determine areas requiring attention. Slow or varying tapchanger operating time can be detected through detailed analysis of voltage regulator control event reports and SER.

Because SEL voltage regulator controls are microprocessor-based, their operating characteristics do not change over time. Operating times are affected only by the voltage regulator control settings and applied signals. It is not necessary to verify operating characteristics as part of maintenance checks.

At SEL, we recommend that maintenance tests on SEL voltage regulator controls be limited under the guidelines provided previously. The time saved may be spent analyzing event data and thoroughly testing those systems that require more attention.

Testing Methods and Tools

Test Features

The following features assist you during voltage regulator control testing.

METER Command. The **METER** command shows the ac current and voltages (magnitude and phase angle) presented to the voltage regulator control in primary values (secondary value magnitudes also available). In addition, the command shows the power system frequency. Compare these quantities against other devices of known accuracy. The **METER** command is available at the serial ports and front-panel display. See *Section 9: Communications* and *Section 10: Front-Panel Operations* in the *SEL-2431 Voltage Regulator Control Instruction Manual*.

HISTORY Command and CEV Command. The voltage regulator control generates a 30-cycle event report in response to abnormal tapchanger operations (see *Section 5: Tap Operations* in the *SEL-2431 Voltage Regulator Control Instruction Manual*). Each report contains current and voltage information, voltage regulator control element states, and input/output contact information. Even motor raise and lower (and hold, for Cooper) currents can be observed. If you question the voltage regulator control response or your test method, use the event report for more information. The **HIS** and **CEV** commands are available at the serial ports. See *Section 11: Analyzing Events* in the *SEL-2431 Voltage Regulator Control Instruction Manual*.

SER Command. The voltage regulator control provides a Sequential Events Recorder (SER) event report that time-tags changes in voltage regulator control element and abnormal tapchanger operations (see *Section 5: Tap Operations* in the *SEL-2431 Voltage Regulator Control Instruction Manual*). The SER provides a convenient means to verify the pickup/dropout of any element in the voltage regulator control. The **SER** command is available at the serial ports. See *Section 11: Analyzing Events* in the *SEL-2431 Voltage Regulator Control Instruction Manual*.

TARGET Command. Use the **TARGET** command to view the state of voltage regulator control inputs, voltage regulator control outputs, and voltage regulator control elements individually during a test. The **TARGET** command is available at the serial ports and the front panel. See *Section 9: Communications* and *Section 10: Front-Panel Operations* in the *SEL-2431 Voltage Regulator Control Instruction Manual*.

PULSE Command. Use the **PULSE** command to test the contact output circuits. The **PULSE** command is available at the serial ports and the front panel. See *Section 9: Communications* and *Section 10: Front-Panel Operations* in the *SEL-2431 Voltage Regulator Control Instruction Manual*.

RAISE/LOWER Commands. Use the **RAISE** and **LOWER** commands to verify the proper operation of the voltage regulator tap mechanism. With factory-default settings, control configuration must be in Remote for these commands to operate.

Test Methods

Test the pickup and dropout of voltage regulator control elements using one of three methods: target command indication, output contact closure, or Sequential Events Recorder (SER).

Testing Via TARGET Commands

Display the state of voltage regulator control elements, inputs, and outputs using the front-panel or serial port **TAR** commands. Use this method to verify the pickup settings of elements.

Testing With the Front-Panel TARGET Command

You can use the front-panel display and navigation pushbuttons to check Device Word bit elements. See *Section 10: Front-Panel Operations* in the *SEL-2431 Voltage Regulator Control Instruction Manual* for more information on using the voltage regulator control front panel.

Display the **MAIN** menu. If the voltage regulator control LCD is in the Rotating Display, press the **ENT** pushbutton to display the **MAIN** menu as shown in *Figure 5.1*.

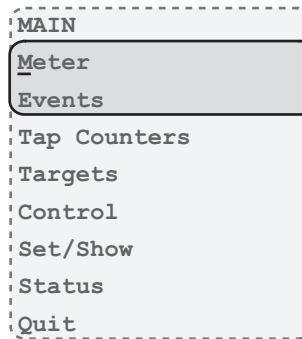

Figure 5.1 Main Menu

Select the **Targets** menu item from the main menu and then use the cursor keys to navigate to the Device Word row that contains the element you wish to view as shown by the **Targets** menu in *Figure 5.2*. You may view the entire row at once or you can select the row using the **ENT** pushbutton to view more detailed information about each Device Word bit in the row selected as shown by the **Targets Display** in *Figure 5.2*.

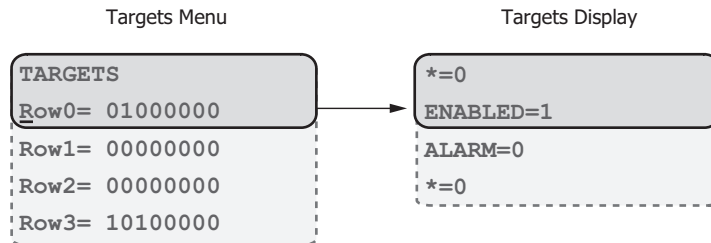

Figure 5.2 Targets Menu and Targets Display

See *Appendix E: Device Word Bits* in the *SEL-2431 Voltage Regulator Control Instruction Manual* for the correspondence between the Device Word elements and the **TAR** command.

Testing With the Serial Port TARGET Command

For example, to view the **HBNDFWD** element status from the serial port, issue the **TAR HBNDFWD** command. The voltage regulator control will display the state of all elements in the Device Word row containing the **HBNDFWD** element.

Review **TAR** command descriptions in *Section 9: Communications* and *Section 10: Front-Panel Operations* in the *SEL-2431 Voltage Regulator Control Instruction Manual* for further details on displaying element status via the **TAR** commands.

Testing Via Output Contacts

You can set the voltage regulator control to operate an output contact for testing a single element. Use the **SET L** command (SELOGIC control equations) to set an output contact (e.g., OUT101 through OUT104) to the element under test. The available elements are the Device Word bits referenced in *Appendix E: Device Word Bits* in the *SEL-2431 Voltage Regulator Control Instruction Manual*.

For example, to test the HBNDPWD element via output contact OUT104, make the following setting:

```
OUT104 := HBNDPWD
```

Do not forget to reenter the correct voltage regulator control settings when you are finished testing and ready to place the voltage regulator control in service.

Testing Via Sequential Events Recorder

You can set the voltage regulator control to generate an entry in the Sequential Events Recorder (SER) for testing voltage regulator control elements. Use the **SET R** command to include the element(s) under test in any of the SER trigger list entries 01 through 96. See *Section 11: Analyzing Events* in the *SEL-2431 Voltage Regulator Control Instruction Manual*.

To test the HBNDPWD element with the SER, make the following setting at the end of the factory-default SER trigger list:



A screenshot of a control panel showing a trigger list entry. The entry is labeled '33:' and contains the text 'HBNDPWD'. There is a question mark '?' to the left of the text.

Element HBNDPWD asserts when regulated voltage is more than the high-band edge. The assertion and deassertion of this element is time-stamped in the SER report.

Do not forget to reenter the correct voltage regulator control settings when you are ready to place the voltage regulator control in service.

Self-Tests

The SEL-2431 continuously runs many self-tests to detect out-of-tolerance conditions. These tests run at the same time as voltage regulator control logic but do not degrade SEL-2431 performance.

Status Warning and Status Failure

The voltage regulator control reports out-of-tolerance conditions as a status warning or a status failure. For conditions that do not compromise voltage regulator control functionality, yet are beyond expected limits, the voltage regulator control issues a status warning and continues to operate. A severe out-of-tolerance condition causes the voltage regulator control to declare a status failure and enter a control-disabled state. During a control-disabled state, the voltage regulator control suspends control element processing and de-energizes all control outputs. When disabled, the **ENABLED** front-panel LED is not illuminated.

The voltage regulator control signals a status warning by pulsing the HALARM Device Word bit (hardware alarm) to logical 1 for five seconds. For a Status Failure, the voltage regulator control latches the HALARM Device Word bit at logical 1. To provide remote status indication, connect the Form B contact of OUT101 to your control system remote alarm input. With factory settings, output contact OUT101 comes programmed as an alarm (logic setting OUT101 := NOT ALARM; front-panel setting ALARM := HALARM OR. . .).

If you repeatedly receive status warnings, check the voltage regulator control operating conditions as soon as possible. Take preventive action early during the development of potential problems to avoid system failures. For any status failure, contact your Technical Service Center or the SEL factory immediately (see *Technical Support on page 5.11*).

The voltage regulator control generates an automatic status report at the serial ports for a self-test status failure if you set Port setting AUTO := Y. The voltage regulator control issues a status message with a format identical to the STATUS command output.

Use the serial port STATUS and CSTATUS commands, the ACSELERATOR QuickSet® SEL-5030 Software HMI Status button, and the front-panel Status menu to display status warnings and status failures. See Section 9: Communications in the SEL-2431 Voltage Regulator Control Instruction Manual for more information on the automatic status notifications and on viewing the voltage regulator control status.

Firmware Version Number

At the top of each status report the voltage regulator control displays the present firmware version number that identifies the software program that controls voltage regulator control functions. The firmware version is the four-place designator immediately following the voltage regulator control model number (the first characters in the firmware identification string). The first character in the four-place firmware version number is “R” (representing “Release”). SEL numbers subsequent firmware releases sequentially; the next revision following R101 is R102.

Status

Use the serial port STATUS command or select the Status menu item from the Main menu on the front-panel HMI to view the self-test status report. An example status report is shown in Section 9: Communications in the SEL-2431 Voltage Regulator Control Instruction Manual. Use Table 5.1 to interpret the self-test results and measurements.

Table 5.1 Status Report Results (Sheet 1 of 2)

Self-Test	Condition	Limits	Control Disabled	HALARM Device Word Bit	Description
PS1.5V	Warning	1.455 V 1.545 V	No	Pulsed	Measures the 1.5 V power supply.
PS1.5V	Failure	1.425 V 1.575 V	Yes	Latched	
PS3.3V	Warning	3.16 V 3.43 V	No	Pulsed	Measures the 3.3 V power supply.
PS3.3V	Failure	3.07 V 3.53 V	Yes	Latched	

Table 5.1 Status Report Results (Sheet 2 of 2)

Self-Test	Condition	Limits	Control Disabled	HALARM Device Word Bit	Description
PS5V	Warning	4.80 V 5.20 V	No	Pulsed	Measures the 5 V power supply.
PS5V	Failure	4.65 V 5.40 V	Yes	Latched	
PS5VA	Warning	4.80 V 5.20 V	No	Pulsed	Measures the 5 V power supply (for analog circuits).
PS5VA	Failure	4.65 V 5.40 V	Yes	Latched	
PSN5V	Warning	-5.60 V -4.40 V	No	Pulsed	Measures the -5 V power supply.
PSN5V	Failure	-5.70 V -4.30 V	Yes	Latched	
PSN5VA	Warning	-5.60 V -4.40 V	No	Pulsed	Measures the -5 V power supply (for analog circuits).
PSN5VA	Failure	-5.70 V -4.30 V	Yes	Latched	
PS12V	Warning	11.28 V 16.40 V	No	Pulsed	Measures the 12 V power supply.
PS12V	Failure	10.92 V 17.00 V	Yes	Latched	
HMI	Warning		No	Pulsed	Checks communication with HMI board.
RAM	Failure		Yes	Latched	Performs a read/write test on system RAM.
NON_VOL	Failure	checksum	Yes	Latched	Performs a checksum test on the nonvolatile copy of the voltage regulator control settings.
CLOCK	Warning		No	Pulsed	Checks for real-time clock communications.
CARD1	Warning		No	Pulsed	Checks for correct communications card in Comm. Port 1 slot (per part number).
CARD2	Warning		No	Pulsed	Checks for correct communications card in Comm. Port 2 slot (per part number).
Master Offset (MOF)	Warning	> 30 mV	No	Pulsed	Measures the dc offset at the A/D.
Channel Offsets ILLOW, ILHIGH, IMH, IMR, IML, V _{S1} , V _{S2}	Warning	> 30 mV	No	Pulsed	Measures the dc offset at each of the input channels.

Voltage Regulator Control Troubleshooting

Inspection Procedure

Complete the following procedure before disturbing the voltage regulator control. After you finish the inspection, proceed to the *Troubleshooting Procedure*. For the following steps, refer to *Figure C.1*, *Figure C.2*, and *Figure C.3*.

- Step 1. Measure and record the power supply voltage at the power input terminals.
- Step 2. Check to see that the power is on. Do not turn the voltage regulator control off.
- Step 3. Measure and record the voltage at all control inputs.

- Step 4. Measure and record the state of all output devices.
- Step 5. Inspect the serial communications ports cabling to be sure that a communications device is connected to at least one communications port.

Troubleshooting Procedure

Troubleshooting procedures for common problems are listed in *Table 5.2*. The table lists each symptom, possible causes, and corresponding diagnoses/solutions. Related SEL-2431 commands are listed in bold capitals. See *Section 9: Communications* in the *SEL-2431 Voltage Regulator Control Instruction Manual* for details on SEL-2431 commands and *Section 8: Settings* in the *SEL-2431 Voltage Regulator Control Instruction Manual* for details on voltage regulator control settings. For more details on the following, see the referenced sections:

- SEL-2431 mounting, grounding, and wiring harnesses (*Section 2: Installation*)
- Fusing and front panel (*Section 3: Front-Panel Interface*)
- General voltage regulator construction and interface (*Appendix B: Voltage Connections, Internal Voltage Regulator Wiring, and Voltage Polarity Reversal*)
- General SEL-2431 internal wiring/functions and extra I/O (*Appendix C: Internal SEL-2431 Wiring and Extra I/O Connections*)

Table 5.2 Troubleshooting Procedures (Sheet 1 of 3)

Symptom/Possible Cause	Diagnosis/Solution
Dark Front Panel	
Power is off.	Check the status of the front-panel CONTROL POWER switch.
Input power is not present.	Verify that power is present at the VOLTAGES connector. If there is no power, verify that all wire harness connections are correct according to Section 2 of this document. For GE NN style wiring harnesses, verify that wiring harness Terminal NN8 is electrically shorted to Terminal NN9 either through a supplied knife switch in the control cabinet or through direct connection (i.e., a jumper wire).
Blown power supply fuse.	Replace the CONTROL fuse.
Poor contrast adjustment.	Press and hold ESC for two seconds. Press Right Arrow and Left Arrow pushbuttons to adjust contrast.
Status Failure Notice on Front Panel	
Self-test failure.	Contact the SEL factory or your Technical Service Center. The OUT101 Form B contact will be closed (comes as an alarm with factory settings).
Alarm Output OUT101 Asserts and ENABLED LED Extinguishes	
Power is off.	Check the status of the front-panel CONTROL POWER switch.
Blown power supply fuse.	Replace the CONTROL fuse.
Power supply failure.	LCD displays STATUS FAILURE . Contact the SEL factory or your Technical Service Center.
Another self-test failure.	Contact the SEL factory or your Technical Service Center.
Alarm Output OUT101 Asserts and ALARM LED Illuminates	
Tapchanger abnormality.	See <i>Section 5: Tap Operations</i> in the <i>SEL-2431 Voltage Regulator Control Instruction Manual</i> .
Self-test failure.	Contact the SEL factory or your Technical Service Center.

Table 5.2 Troubleshooting Procedures (Sheet 2 of 3)

Symptom/Possible Cause	Diagnosis/Solution
System Does Not Respond to Commands	
No communication.	Confirm cable connections and types. If OK, type <Ctrl+X>, then <Enter>. This resets the terminal program.
Communications device is not connected to the system.	Connect a communications device.
Incorrect data speed (baud rate) or other communications parameters.	Configure your terminal port parameters to the particular voltage regulator control port settings. Use the front panel to check port settings.
Incorrect communications cables.	Use SEL communications cables or cables you build according to SEL specifications.
Communications cabling error.	Check cable connections.
Handshake line conflict; system is attempting to transmit information, but cannot do so.	Check communications cabling. Use SEL communications cables or cables you build according to SEL specifications.
System is in the XOFF state, halting communications.	Type <Ctrl+Q> to put the system in the XON state.
Terminal Displays Meaningless Characters	
Data speed (baud rate) is set incorrectly.	Check the terminal parameters configuration.
Terminal emulation is not optimal.	Try other terminal types, including VT-100 and VT-52 terminal emulations.
System Does Not Respond to Voltage Changes	
Voltage regulator control is set improperly.	Review the voltage regulator control settings.
Improper test settings.	Restore operating settings.
Connection wiring error.	Confirm the correct wiring harness is being used.
Input voltages and current phasing errors.	Use voltage regulator control metering. Use the TRI event trigger command and examine the generated event report.
Blown motor fuse	Replace the MOTOR fuse.
Blown second voltage fuse	Replace the in-line fuse for Terminal 3 of the VOLTAGES connector.
Output Contact Remains Closed Following an Operation	
Voltage regulator control outputs have burned closed.	Remove voltage regulator control power. Remove the control output connection. Check continuity; Form A contacts will be open and Form B contacts will be closed. Contact the SEL factory or your Technical Service Center if continuity checks fail.
Check the voltage regulator control self-test status.	Take preventive action as directed by voltage regulator control Status Warning and Status Failure information.
Power Supply Voltage Status Warning	
Power supply voltage(s) are out-of-tolerance.	Log the Status Warning. If repeated warnings occur, take preventive action.
Power Supply Voltage Status Failure	
Power supply voltage(s) are out-of-tolerance.	LCD displays STATUS FAILURE. Contact the SEL factory or your Technical Service Center.
Channel Offset Status Warning	
A/D converter drift.	Log the Status Warning. If repeated warnings occur, contact the SEL factory or your Technical Service Center.
Master offset drift.	Log the Status Warning. If repeated warnings occur, contact the SEL factory or your Technical Service Center.
Meter Command Does Not Respond as Expected	
Current magnitude is incorrect.	Global setting CTPRIM is not set correctly.
Voltage magnitudes are incorrect.	Global settings PT1PRIM, PT1SEC, PT2PRIM, PT2SEC, BASE_PRI, or BASE_SEC is not set correctly.

Table 5.2 Troubleshooting Procedures (Sheet 3 of 3)

Symptom/Possible Cause	Diagnosis/Solution
Voltage magnitude is low.	Check return wiring for V_{S2} ; ensure it has a solid return path.
Current or voltage angles or power magnitudes are incorrect.	Voltage regulator control analog inputs not connected correctly. Global setting CTPOL, PT1POL, PT2POL, CONFIG, DELTA, D_LAG, D_LEAD, or ISHIFT is not set correctly.
Multimeter on VOLTMETER terminals disagrees with metering screens.	Voltage Base difference. Harmonics (ignored by the SEL-2431, included by true rms multimeters) Low-impedance voltmeters may not measure the voltage at the voltmeter terminals accurately because these terminals are impedance-protected.

Technical Support

We appreciate your interest in SEL products and services. If you have questions or comments, please contact us at:

Schweitzer Engineering Laboratories, Inc.
 2350 NE Hopkins Court
 Pullman, WA 99163-5603 U.S.A.
 Tel: +1.509.338.3838
 Fax: +1.509.332.7990
 Internet: selinc.com/support
 Email: info@selinc.com

This page intentionally left blank

Appendix A

Field Reference Guide Versions

The date code at the bottom of each page of this guide reflects the creation or revision date.

Table A.1 lists the release dates and a description of modifications. The most recent revisions are listed at the top.

Table A.1 Field Reference Guide Revision History (Sheet 1 of 4)

Revision Date	Summary of Revisions
20260216	<p>Appendix F</p> <ul style="list-style-type: none"> ➤ Updated <i>SEL-2401 Satellite-Synchronized Clock</i>. ➤ Updated <i>Table F.4: 19-Pin Universal Interface Wiring</i>. ➤ Updated <i>Figure F.6: 19-Pin Universal Interface Wiring Diagram</i>.
20250722	<p>Section 2</p> <ul style="list-style-type: none"> ➤ Updated <i>Figure 2.9: GE Traditional (Fork-Terminal Connections) Control Wiring Harness</i>. ➤ Updated <i>SEL-2431 Enclosure 19-Pin Universal Interface Terminal Block Connector Wiring</i>. ➤ Updated <i>Figure 2.16: Enclosure Wiring Cross-Reference to Common Voltage Regulator Interfaces</i>. ➤ Updated <i>Eaton/Cooper 12-Conductor Interface</i>. <p>Appendix F</p> <ul style="list-style-type: none"> ➤ Added <i>IEEE 19-Pin Universal Interface</i>. <p>Appendix G</p> <ul style="list-style-type: none"> ➤ Updated <i>Figure G.2: Voltage Regulator Control Enclosure's RCT Point-to-Point Wiring Diagram</i>.
20240909	<p>Section 1</p> <ul style="list-style-type: none"> ➤ Added <i>Voltage Regulator Control Enclosure</i>. ➤ Added <i>Figure 1.5: SEL-2431 Enclosure Dimensions</i>. <p>Section 2</p> <ul style="list-style-type: none"> ➤ Updated <i>Mounting the Control in Retrofit Applications</i>. ➤ Added <i>Mounting the Voltage Regulator Control Enclosure</i>. ➤ Updated <i>Connect the Wiring Harness From the Voltage Regulator Interface to the SEL-2431</i>. ➤ Updated for compatibility with Romagnole SVR voltage regulator. <p>Section 4</p> <ul style="list-style-type: none"> ➤ Updated for compatibility with Romagnole SVR voltage Regulator. <p>Appendix B</p> <ul style="list-style-type: none"> ➤ Updated <i>Figure B.11: Romagnole SVR Regulator/Control Wiring Harness Interface</i>. <p>Appendix F</p> <ul style="list-style-type: none"> ➤ Added new appendix. <p>Appendix G</p> <ul style="list-style-type: none"> ➤ Added new appendix.
20240308	<p>Section 1</p> <ul style="list-style-type: none"> ➤ Updated <i>Table 1.1: SEL-2431 Retrofit Kits</i>.

Table A.1 Field Reference Guide Revision History (Sheet 2 of 4)

Revision Date	Summary of Revisions
20230606	<p>Section 4</p> <ul style="list-style-type: none"> ➤ Updated range of group setting OPMODE with new option FLEXDG (Flexible Distributed Generation operation mode) in <i>Basic Group Settings</i>. ➤ Added new group settings BIASMODE, FLEX_50, TAPDELTL, and TAPDELTH to <i>Basic Group Settings</i> (last three settings exclusively for new Flexible Distributed Generation operation mode). ➤ Revised settings rule at front of <i>Basic Group Settings/Reverse Controller Settings</i> to allow for OPMODE := FLEXDG. ➤ Updated range of group setting ELDC for OPMODE := FLEXDG in <i>Basic Group Settings/Line-Drop Compensation Settings</i>.
20220809	<p>Section 2</p> <ul style="list-style-type: none"> ➤ Added <i>ITB Voltage Regulator Control Wiring Harness</i>. <p>Section 4</p> <ul style="list-style-type: none"> ➤ Updated <i>Regulator Nameplate Data</i> to include ITB RAV-2. <p>Appendix B</p> <ul style="list-style-type: none"> ➤ Added <i>Figure B.10: ITB RAV-2 Regulator/Control Wiring Harness Interface</i>.
20200604	<p>Section 3</p> <ul style="list-style-type: none"> ➤ Added a note about pressing and holding the DRAG HAND RESET pushbutton. <p>Section 5</p> <ul style="list-style-type: none"> ➤ Updated <i>Technical Support</i>.
20160921	<p>Section 2</p> <ul style="list-style-type: none"> ➤ Updated for compatibility with Toshiba CR-3 voltage regulator. <p>Appendix B</p> <ul style="list-style-type: none"> ➤ Added <i>Figure B.9: Toshiba CR-3 Regulator/Control Wiring Harness Interface</i> and text to detail compatibility with Toshiba CR-3 voltage regulator.
20150416	<p>Preface</p> <ul style="list-style-type: none"> ➤ Updated <i>Safety Information</i>. <p>Section 3</p> <ul style="list-style-type: none"> ➤ Updated <i>Table 3.2: Report Files Stored During Read Reports and Automatic Backup</i>.
20140930	<p>Section 2</p> <ul style="list-style-type: none"> ➤ Added <i>Synchronize the Tap Position</i>. <p>Section 3</p> <ul style="list-style-type: none"> ➤ Added note to <i>Display and Navigation Pushbuttons</i>. ➤ Added instructions to <i>Operation and Indication LEDs</i>. ➤ Added instructions to <i>Voltage Regulator Bypassing</i>.
20140508	<p>Section 5</p> <ul style="list-style-type: none"> ➤ Added entry for low-voltage magnitude in <i>Table 5.2: Troubleshooting Procedures</i>.
20121213	<p>Section 3</p> <ul style="list-style-type: none"> ➤ Added Type A USB features. <p>Section 4</p> <ul style="list-style-type: none"> ➤ Added LDC limit settings. ➤ Added alternate setting range for overcurrent settings.
20120201	<p>Section 2</p> <ul style="list-style-type: none"> ➤ Modified instructions for GE Voltage Regulator Control Wiring Harness (Traditional Interface). <p>Section 3</p> <ul style="list-style-type: none"> ➤ Clarified description of AUTO INHIBIT LED. <p>Section 5</p> <ul style="list-style-type: none"> ➤ Modified <i>Table 5.2: Troubleshooting Procedures</i>.

Table A.1 Field Reference Guide Revision History (Sheet 3 of 4)

Revision Date	Summary of Revisions
20110614	<p>Section 1</p> <ul style="list-style-type: none"> ➤ Modified <i>Table 1.1: SEL-2431 Retrofit Kits</i>. ➤ Added <i>Table 1.2: SEL-2431 Mounting Hardware Kits</i>.
20110208	<p>Section 1</p> <ul style="list-style-type: none"> ➤ Updated number of available display points to 32. <p>Section 2</p> <ul style="list-style-type: none"> ➤ Modified <i>Figure 2.8: GE Traditional (Fork Terminal Connections) Control Wiring Harness</i> to show jumper between NN24 and GND. ➤ Added <i>Figure 2.10: Generic Control Wiring Harness (Siemens, Howard, or GE)</i>. ➤ Added <i>Figure 2.11: Generic Control Wiring Harness (Cooper or McGraw)</i>. <p>Section 3</p> <ul style="list-style-type: none"> ➤ Updated default display points. <p>Section 4</p> <ul style="list-style-type: none"> ➤ Widened center band voltage range (F_CNBND and R_CNBND). <p>Appendix B</p> <ul style="list-style-type: none"> ➤ Clarified required voltage connections in <i>Understanding Voltage Sources and Settings Correspondence Before Making Connections</i>. <p>Appendix E</p> <ul style="list-style-type: none"> ➤ Modified the allowable range between (PT1PRIM/PT1SEC) and (BASE_PRI/BASE_SEC).
20100112	<p>Section 4</p> <ul style="list-style-type: none"> ➤ Added TAPDUR and TPFBDK settings to <i>Regulator Nameplate Data</i>.
20081219	<p>Section 5</p> <ul style="list-style-type: none"> ➤ Updated <i>Table 5.2: Troubleshooting Procedures</i>.
20080910	<p>Section 3</p> <ul style="list-style-type: none"> ➤ Added note that tap mechanism can be controlled by toggle switch MOTOR CONTROL RAISE/LOWER version when the SEL-2431 control is disabled, and tap mechanism cannot be controlled via the pushbutton MOTOR CONTROL RAISE/LOWER version when the SEL-2431 control is disabled. <p>Section 4</p> <ul style="list-style-type: none"> ➤ Added CTPOL, PT2POL, and ISHIFT Global settings. <p>Section 5</p> <ul style="list-style-type: none"> ➤ Updated <i>Table 5.2: Troubleshooting Procedures</i>. <p>Appendix B</p> <ul style="list-style-type: none"> ➤ Described use of CTPOL, PT1POL, PT2POL, and ISHIFT Global settings.
20080421	<p>Section 3</p> <ul style="list-style-type: none"> ➤ Modified AUTO INHIBIT LED definition. <p>Section 4</p> <ul style="list-style-type: none"> ➤ Modified lower setting limit of TD2. ➤ Modified setting rules for voltage reduction settings VREDFP2, VREDFP3, VREDRP2, and VREDRP3. ➤ Settings explanation added for SELOGIC Group settings INHIBSV and BLOCKSV. <p>Appendix B</p> <ul style="list-style-type: none"> ➤ Added note that Cooper regulator controls may have regulated from VS terminal whereas the SEL-2431 regulates from the VM terminal.

Table A.1 Field Reference Guide Revision History (Sheet 4 of 4)

Revision Date	Summary of Revisions
20071018	<p>Section 2</p> <ul style="list-style-type: none"> ➤ Added chassis ground screw size information. ➤ Clarified connection to interface terminal NN20, NN21, or NN22 for <i>Figure 2.8: GE Traditional (Fork Terminal Connections) Control Wiring Harness</i>. ➤ Added note reminding of need to press latch firmly on communications card when installing to <i>Jumpers and Clock Battery</i>. <p>Section 3</p> <ul style="list-style-type: none"> ➤ Added <i>Setting Voltage Regulator Tap Position</i>. <p>Section 4</p> <ul style="list-style-type: none"> ➤ For Global settings PT1POL, PT1PRIM, PT1SEC, PT2PRIM, and PT2SEC, added reference information on how these settings relate to particular voltages on the interface terminals shown in figures in <i>Appendix B: Voltage Connections, Internal Voltage Regulator Wiring, and Voltage Polarity Reversal</i>. <p>Appendix B</p> <ul style="list-style-type: none"> ➤ Added notes for <i>Figure B.1: General Design of a Siemens or Howard Type A (Straight) Voltage Regulator</i> through <i>Figure B.4: General Design of a GE Type B (Inverted) Voltage Regulator</i>, clarifying voltage correspondence. Added cross references to <i>Figure B.1: General Design of a Siemens or Howard Type A (Straight) Voltage Regulator</i> through <i>Figure B.4: General Design of a GE Type B (Inverted) Voltage Regulator</i>, referring forward to other figures. ➤ Added cross references to <i>Figure B.5: Siemens or Howard Regulator/Control Wiring Harness Interface</i> through <i>Figure B.10: Voltage Details for Siemens or Howard Type A (Straight) Regulator/Control Wiring Harness Interface</i>, referring back to wiring harness figures in <i>Section 2: Installation</i>.
20070920	<p>General</p> <ul style="list-style-type: none"> ➤ Removed references to the second voltage input ordering option throughout the guide. <p>Section 2</p> <ul style="list-style-type: none"> ➤ Updated <i>Figure 2.5: Siemens (Polarized Disconnect Switch [PDS]) or Howard (Connector Terminal Strip [CTS]) Control Wiring Harness</i> by indicating a jumper between interface terminals E-E1 (for Siemens voltage regulators) and G-CO (for Howard voltage regulators). <p>Section 5</p> <ul style="list-style-type: none"> ➤ Updated PSN5V and PSN5VA Warning and Failure Limits in <i>Table 5.1: Status Report Results</i>.
20070601	<ul style="list-style-type: none"> ➤ Initial version.

Appendix B

Voltage Connections, Internal Voltage Regulator Wiring, and Voltage Polarity Reversal

Understand Voltage Sources and Settings Correspondence Before Making Connections

Figure B.1 through Figure B.4 show the general layout and available currents and voltages of the voltage regulators supported by the SEL-2431:

- Type A (Straight) voltage regulators (*Figure B.1* and *Figure B.2*) have the shunt winding on the source-side
- Type B (Inverted) voltage regulators (*Figure B.3* and *Figure B.4*) have the shunt winding on the load-side

NOTE: The “Source,” “Load,” “Raise,” and “Lower” designations in *Figure B.1* through *Figure B.4* are for power flow in the conventional forward direction (power flowing from “Source” to “Load”). If power is flowing in the reverse direction (power flowing from “Load” to “Source”), tap operation in the “Lower” direction would actually raise the voltage on the “Source” side (and a tap operation in the “Raise” direction would lower the voltage on the “Source” side).

The shunt winding is energized by the respective system voltage it is connected to (source or load voltage). The series winding, on which tapping is done for the ± 10 percent voltage adjustment, is magnetically coupled to the shunt winding. Any potential transformer (whether internally or externally connected) is not magnetically coupled to any other winding and functions independently, providing secondary voltage for the voltage regulator control.

Notice the tap fingers in *Figure B.1* through *Figure B.4*, on the N (neutral) position. *Section 5: Tap Operations* in the *SEL-2431 Voltage Regulator Control Instruction Manual* covers some of its operation details, going tap-to-tap. For further tap fingers hardware details (e.g., balance winding and preventive autotransformer), consult the voltage regulator instruction manual.

Secondary Voltage Connection Differences Among Voltage Regulators

Notice that the Siemens/Howard Type A voltage regulator in *Figure B.1* differs from other voltage regulators represented in *Figure B.2* through *Figure B.4*. The source voltage is designated as V_{S1} and the load voltage is designated as V_{S2} in the Siemens/Howard Type A voltage regulator in *Figure B.1* (the reverse is true in the other voltage regulators represented in *Figure B.2* through *Figure B.4*).

The secondary voltage V_{S1} always follows the shunt winding (*Figure B.1* and *Figure B.3*) in the Siemens/Howard design.

These secondary voltages V_{S1} and V_{S2} (from *Figure B.1* through *Figure B.4*) are carried through the subsequent interface connections (*Figure B.5* through *Figure B.13*), control harness wiring (*Figure 2.6* through *Figure 2.15*), and into the SEL-2431 (see *Figure C.1*, lower left corner).

Secondary Voltage Correspondence to Global Settings

Secondary voltages V_{S1} and V_{S2} correspond to the following Global settings:

- V_{S1} : PT1POL, PT1PRIM, PT1SEC
- V_{S2} : 2ND_PT, PT2POL, PT2PRIM, PT2SEC

Global setting 2ND_PT (Second PT Connected) is not offered/made if the regulator is a Howard Type A voltage regulator (*Figure B.1*), for which a second voltage (V_{S2}) is always connected.

Subsequent Global settings PT2PRIM and PT2SEC are offered/made if either of the following is true:

- Global setting 2ND_PT := Y (second voltage [V_{S2}] is connected)
- The regulator is a Howard Type A voltage regulator, for which a second voltage (V_{S2}) is always connected

NOTE: In Figure B.1, V_{S1} displays as VS in event reporting and metering. V_{S2} displays as VL in event reporting and metering. VS and VL in metering are normalized to the voltage base (see Appendix E: Voltage Base and Ratio Correction Transformer).

NOTE: Siemens Type A voltage regulators are available without a potential transformer between the L and SL bushings. Set 2ND_PT = N for these voltage regulators.

NOTE: In Figure B.2 through Figure B.4, V_{S1} displays as VL in event reporting and metering. V_{S2} is optional (requires the installation of an external potential transformer) and displays as VS in event reporting (and metering if Global setting 2ND_PT := Y). Otherwise, VS in metering is calculated from V_{S1} (adjusted by known tap position and load). VS and VL in metering are normalized to the voltage base (see Appendix E: Voltage Base and Ratio Correction Transformer).

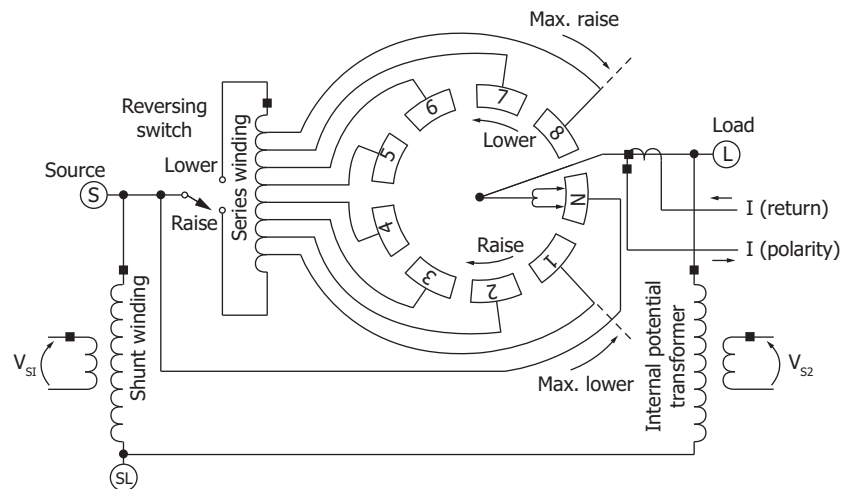

See Figure B.13 for V_{S1} and V_{S2} terminal correspondence.

Figure B.1 General Design of a Siemens or Howard Type A (Straight) Voltage Regulator

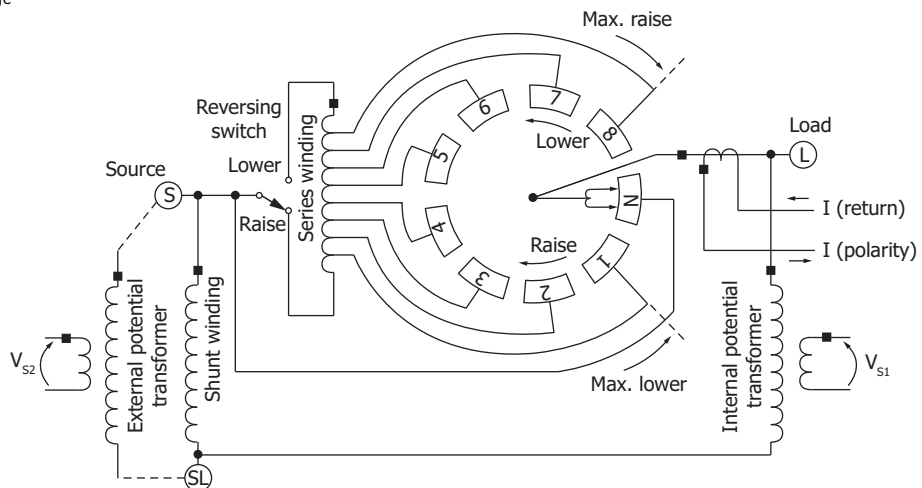

See Figure B.6 (Cooper) for V_{S1} and V_{S2} terminal correspondence.

See Figure B.7 (GE Traditional) for V_{S1} terminal correspondence.

See Figure B.8 (GE Power Disconnect) for V_{S1} terminal correspondence.

Figure B.2 General Design of a GE or Cooper Type A (Straight) Voltage Regulator

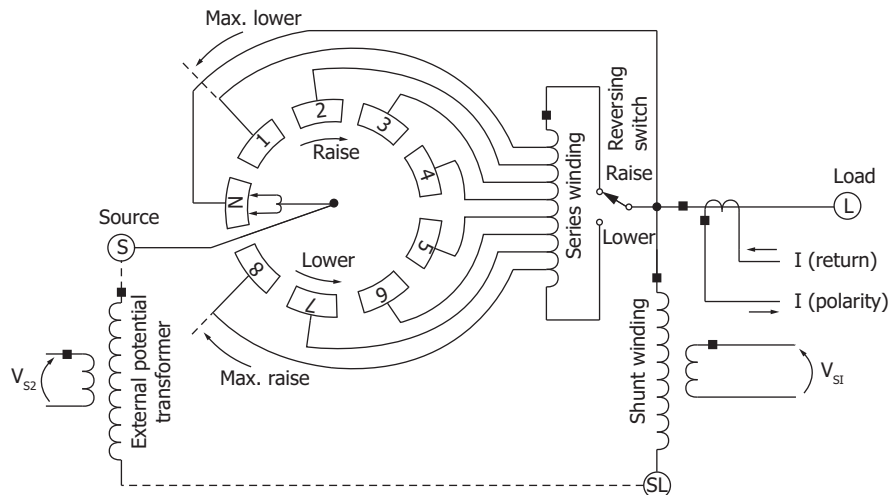

See Figure B.6 (Cooper) for V_{S1} and V_{S2} terminal correspondence.
 See Figure B.9 (Toshiba CR-3) for V_{S1} terminal correspondence.
 See Figure B.10 (ITB RAV-2) for V_{S1} terminal correspondence.
 See Figure B.11 (Romagnole SVR) for V_{S1} terminal correspondence.
 See Figure B.12 (Siemens or Howard) for V_{S1} and V_{S2} terminal correspondence.

Figure B.3 General Design of a Siemens, Howard, Cooper, Toshiba CR-3, ITB RAV-2, or Romagnole SVR Type B (Inverted) Voltage Regulator

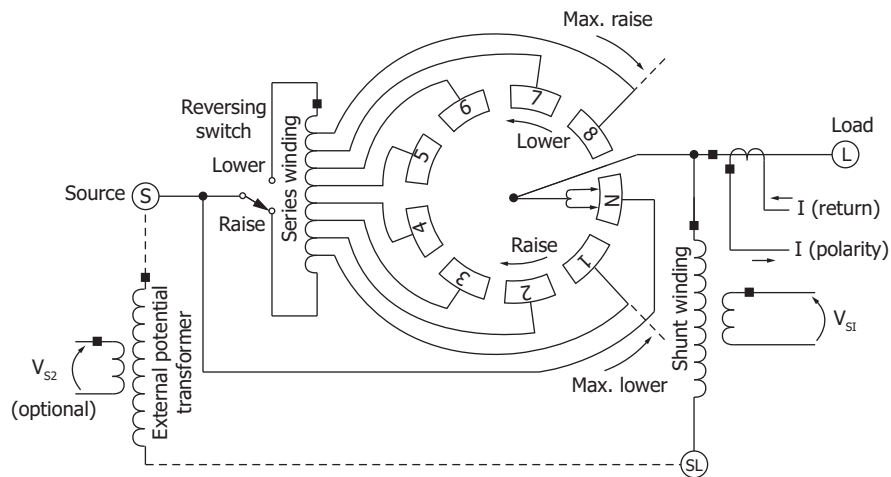

See Figure B.7 (GE Traditional) for V_{S1} terminal correspondence.
 See Figure B.8 (GE Power Disconnect) for V_{S1} terminal correspondence.

Figure B.4 General Design of a GE Type B (Inverted) Voltage Regulator

Make Preparatory Voltage Connections to the Voltage Regulator Interface; Internal Voltage Regulator Wiring

⚠ WARNING
 In the many connection procedures that follow, de-energize the involved circuits and follow other standard safety procedures in making the connections. Consult the voltage regulator instruction manual for more information.

The voltages and currents from the voltage regulators shown in *Figure B.1* through *Figure B.4* are brought to the regulator/control wiring harness interfaces shown in *Figure B.5* through *Figure B.13*, along with other circuits from the voltage regulator (e.g., motor raise/lower, neutral position switch, drag hand reset).

Connections Specific to the Siemens/Howard Voltage Regulator Interface

The existing and new connections shown/discussed in this subsection (*Figure B.5 through Figure B.13* and accompanying text) are, for the most part, *not* connections made directly to the SEL-2431. These new connections are *made in preparation* for the SEL-2431 to be connected via a wiring harness in *Connect the Wiring Harness From the Voltage Regulator Interface to the SEL-2431* on page 2.5.

Notice that *Figure B.5* applies to both the Siemens and Howard voltage regulators (just different names on the interface terminals). The Siemens interface terminal names will be used in any following examples.

The top sub-figure (labeled “original wiring”) in *Figure B.12* is an addition to *Figure B.5*, showing voltage connection V_{S1} for the Siemens/Howard Type B voltage regulator in *Figure B.3* (secondary voltage V_{S1} is brought across interface Terminals U2-E by a wire jumper).

Figure B.13 is also an addition to *Figure B.5*, showing voltage connections V_{S1} and V_{S2} for the Siemens/Howard Type A voltage regulator in *Figure B.1*.

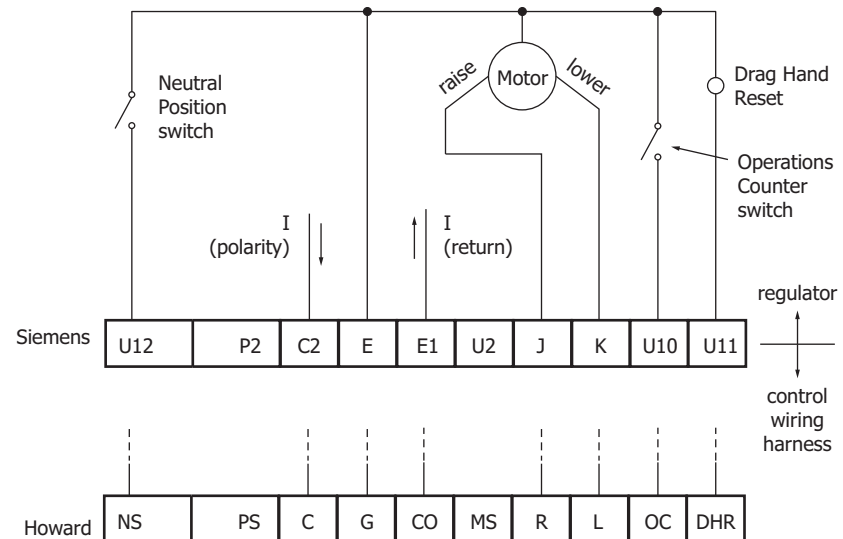

Corresponds to Figure 2.6. See Figure B.12 and Figure B.13 for voltage connections.

Figure B.5 Siemens or Howard Regulator/Control Wiring Harness Interface

Connections Specific to the Cooper Voltage Regulator Interface

NOTE: For some retrofit applications, the Cooper voltage regulator control may have regulated from the VS terminal voltage where the SEL-2431 regulates from the Terminal VM voltage.

In Cooper installations (*Figure B.6*), notice the jumper (dashed line) between Terminals VS and VM on the regulator side of the interface. It is not imperative that this jumper be in place at this exact location, but Terminals VS and VM need to be energized by some means for Cooper voltage regulators. The voltage source details for Terminal VM need to be known so that corresponding Global settings PT1PRIM and PT1SEC (corresponding to voltage V_{S1}) can be entered. Trace Terminal VM (*Figure B.6*) through corresponding *Figure 2.7* (traditional Cooper)/*Figure 2.8* (dead-front Cooper) and on to *Figure C.1* (SEL-2431 internal wiring) and see that voltage input V_{S1} (lower left corner of *Figure C.1*) is energized by Terminal VM for Cooper voltage regulator installations. Likewise, the SEL-2431 power supply (upper half of *Figure C.1*) is energized by Terminal VS (*Figure B.6*) for Cooper voltage regulator installations (trace through the same figures).

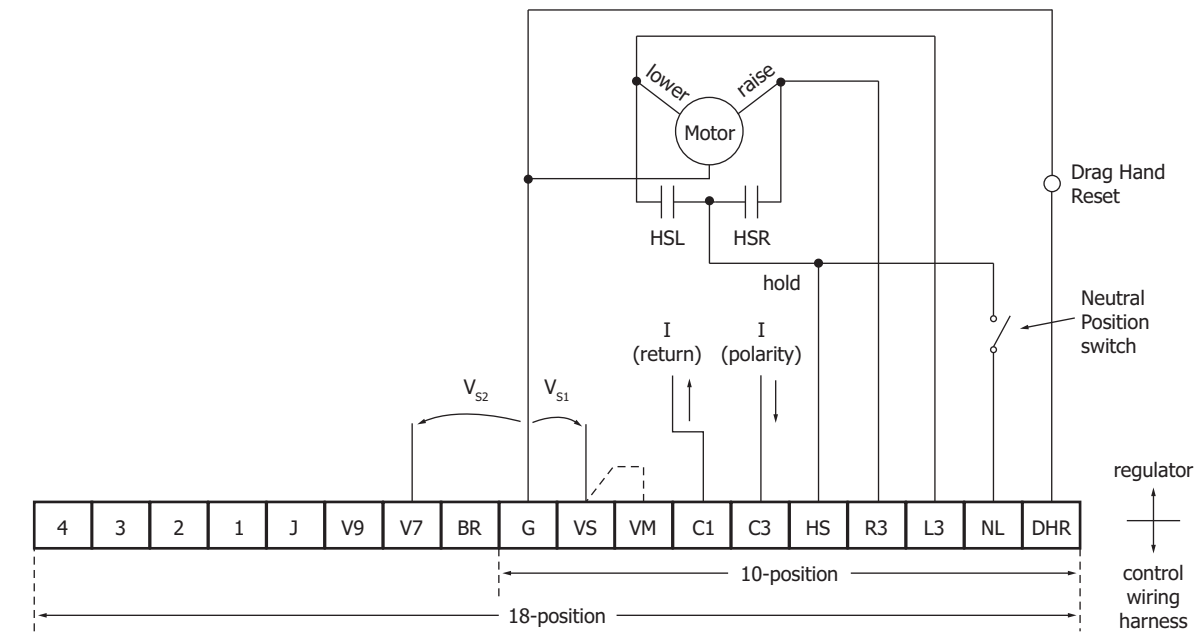

Corresponds to Figure 2.7 and Figure 2.8.

Figure B.6 Cooper Regulator/Control Wiring Harness Interface

Add a Second Voltage

The second voltage input (V_{S2}) of the SEL-2431 is always connected when applied to a Howard Type A voltage regulator (*Figure B.1* and *Figure B.13*).

Connecting the second voltage input (V_{S2}) is optional when the SEL-2431 is applied to the other voltage regulators in *Figure B.2* through *Figure B.4*. The external potential transformers shown in *Figure B.2* through *Figure B.4* (providing secondary voltage V_{S2} for the second voltage input) are special ordered with the voltage regulator or customer installed.

Note that Terminal 4 of the **VOLTAGES** connector on the SEL-2431 is the common reference for both V_{S1} and V_{S2} inside the SEL-2431 (follow *Figure C.1* from the upper right corner, counter-clockwise to lower left corner).

Add a Second Voltage for Cooper Voltage Regulators (Figure B.2 and Figure B.3)

The 18-position regulator/control wiring harness interface in *Figure B.6* provides room for a second voltage (V_{S2}) to be connected.

The 10-position regulator/control wiring harness interface in *Figure B.6* does not provide room for a second voltage (V_{S2}) to be connected, but a second voltage can still be accommodated. See *Cooper Voltage Regulator Control Wiring Harness (Traditional Interface)* on page 2.6.

Add a Second Voltage for GE Voltage Regulators (Figure B.2 and Figure B.4)

No second voltage allowance is made on the GE interfaces (*Figure B.7* and *Figure B.8*), but a second voltage can still be accommodated as follows.

In *Figure 2.9* (traditional, corresponding to *Figure B.7*) or *Figure 2.10* (Power Disconnect, corresponding to *Figure B.8*), connect a second voltage (V_{S2}) between:

- The provided wire on Terminal 3 of the **VOLTAGES** connector on the SEL-2431
- **GND** (voltage regulator enclosure ground)

B.6 | Voltage Connections, Internal Voltage Regulator Wiring, and Voltage Polarity Reversal
Make Preparatory Voltage Connections to the Voltage Regulator Interface; Internal Voltage Regulator Wiring

For background, Terminal 4 of the **VOLTAGES** connector on the SEL-2431 (the common reference for both V_{S1} and V_{S2}) is already connected to **GND**, via the control wiring harness, as shown in:

- *Figure 2.9*—Terminal 4 of the **VOLTAGES** connector connects to interface Terminal **NN10** (V_{S1} reference) and then to **GND**
- *Figure 2.10*—Terminal 4 of the **VOLTAGES** connector connects to interface Terminal **20** (V_{S1} reference) and also to **GND**

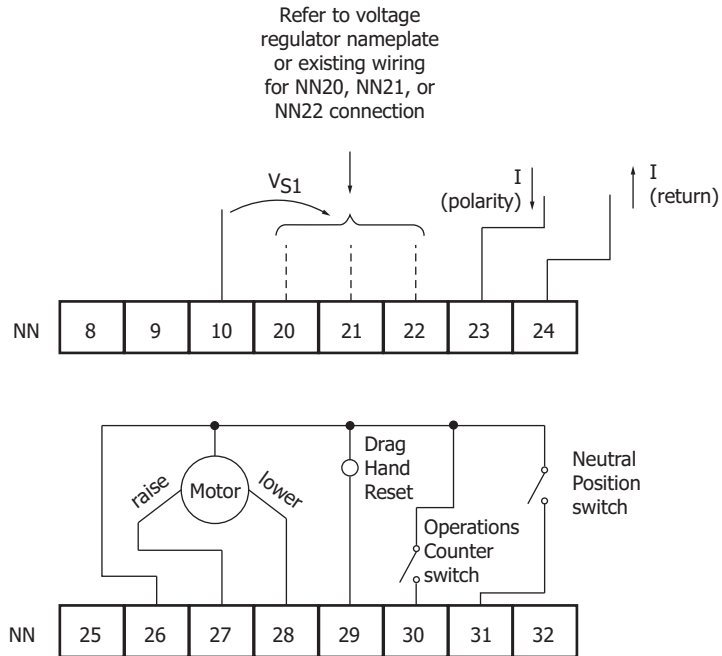

Corresponds to Figure 2.9.

Figure B.7 GE Traditional Regulator/Control Wiring Harness Interface

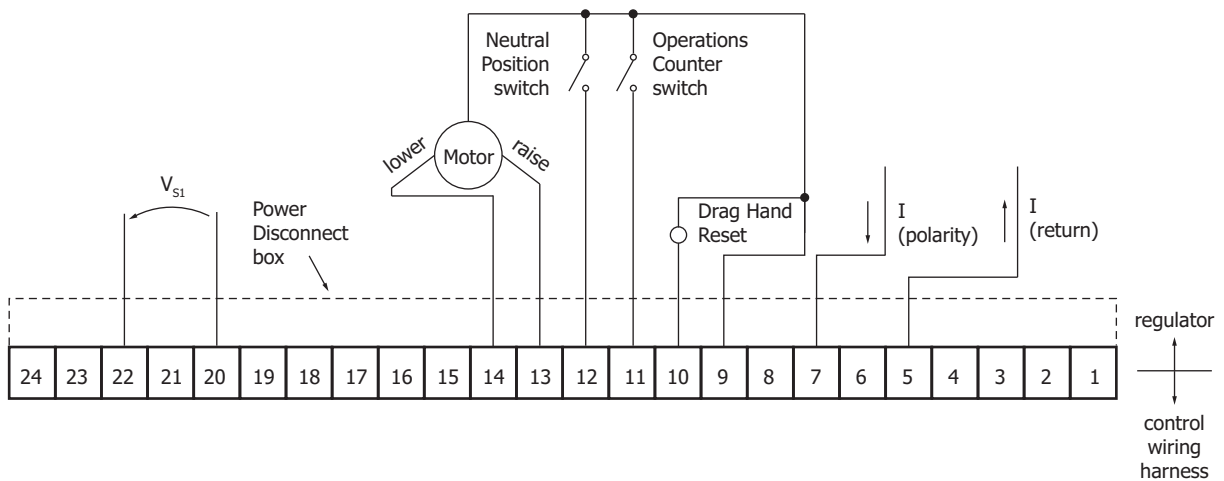

Corresponds to Figure 2.10.

Figure B.8 GE Power Disconnect Regulator/Control Wiring Harness Interface

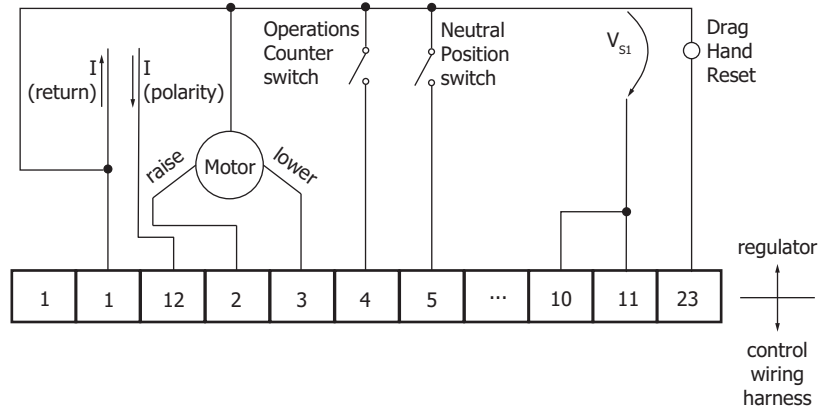

Corresponds to Figure 2.13.

Figure B.9 Toshiba CR-3 Regulator/Control Wiring Harness Interface

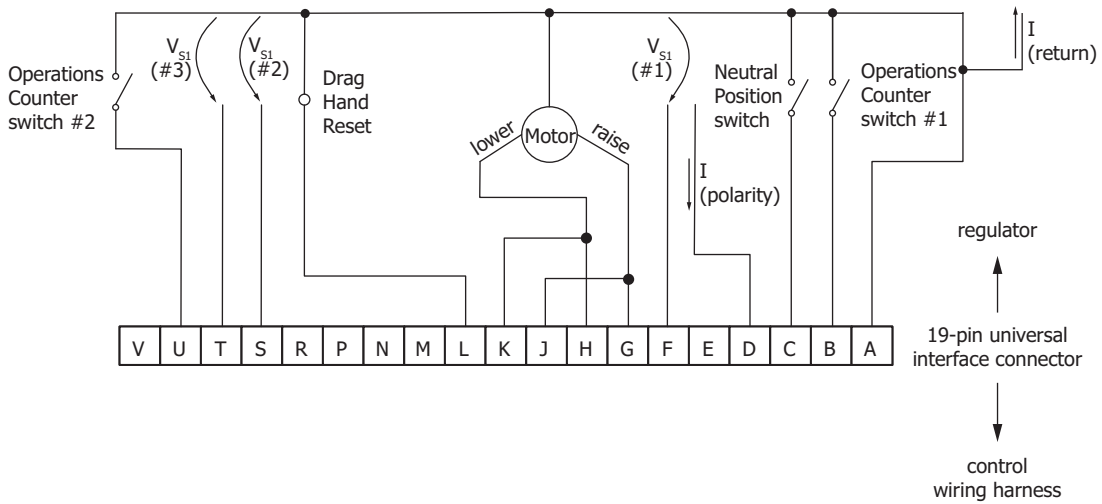

Consult the ITB RAV-2 instruction manual about which voltage V_{S1} tap (#1, #2, or #3) should be connected to **VOLTAGES** Terminal 1 (see Figure 2.15).

Corresponds to Figure 2.15.

Figure B.10 ITB RAV-2 Regulator/Control Wiring Harness Interface

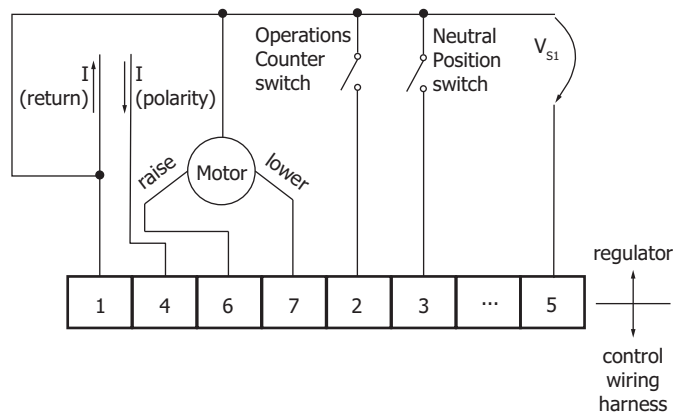

Figure B.11 Romagnole SVR Regulator/Control Wiring Harness Interface

Add a Second Voltage for Siemens/Howard Type B Voltage Regulators (Figure B.3)

At the top of *Figure B.12* (“original wiring,” an addition to *Figure B.5*), voltage V_{S1} comes jumpered over to interface Terminal **U2** (interface Terminals **U2-E** expect secondary voltage V_{S1} to be across them). Follow the sequence of *Figure B.12* to add a second voltage (V_{S2}), if the wiring change has not already been made:

1. Remove the wire jumper between interface Terminals **P2** and **U2**.
2. Move the wire from interface Terminal **P2** to **U2** (voltage V_{S1} is now across interface Terminals **U2-E**).
3. Install the wires from the external potential transformer to put the additional secondary voltage V_{S2} across interface Terminals **P2-E**.

For background, in *Figure 2.6* (corresponding to *Figure B.5* and *Figure B.12*), note that interface Terminal **E** is connected to Terminal **4** of the **VOLTAGES** connector on the SEL-2431 (the common reference for both V_{S1} and V_{S2}).

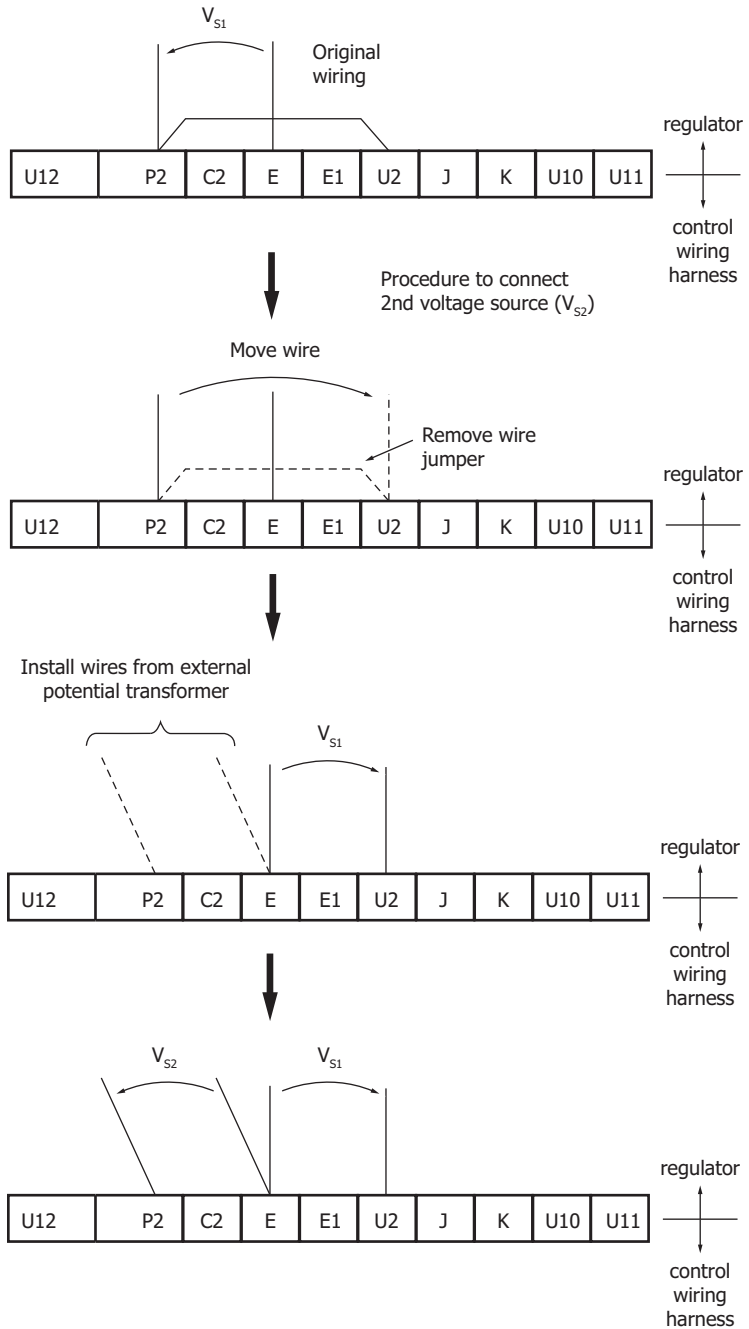

Corresponds to Figure 2.6. See Figure B.5 for other connections.

Figure B.12 Adding a Second Voltage to a Siemens or Howard Type B (Inverted) Regulator/Control Wiring Harness Interface (Siemens Shown, Howard Similar)

Voltage and Current Polarity Reversal

Normal polarity is inferred for secondary voltages V_{S1} and V_{S2} in *Figure B.1* through *Figure B.4*. Sometimes there is a polarity reversal on secondary voltages V_{S1} or V_{S2} .

For example, consider the Siemens/Howard Type A voltage regulator in *Figure B.1*, with its corresponding voltage connections in *Figure B.13* (an addition to *Figure B.5*). These two figures infer normal polarity connections (the non-polarity leads of the voltage secondaries share a common connection on interface Terminal E in *Figure B.13*).

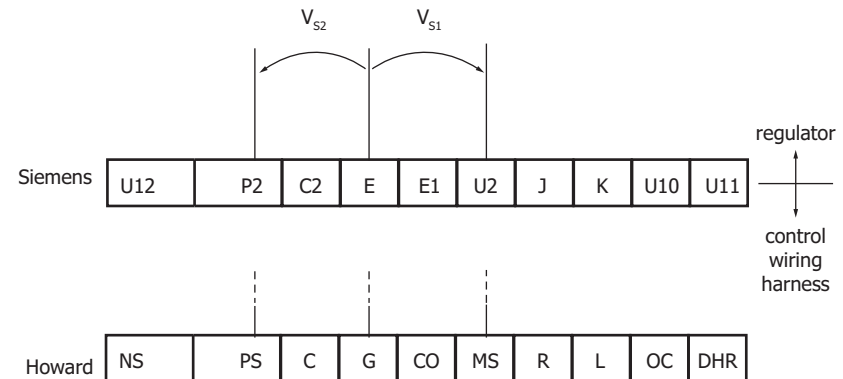

Corresponds to *Figure 2.6*. See *Figure B.5* for other connections.

Figure B.13 Voltage Details for Siemens or Howard Type A (Straight) Regulator/Control Wiring Harness Interface

Now, presume that the polarity lead of V_{S1} in *Figure B.1* is connected to interface Terminal E in *Figure B.13* instead. This would necessitate the non-polarity lead of V_{S1} in *Figure B.1* being connected to interface Terminal U2. A complete polarity reversal has occurred for secondary voltage V_{S1} from the perspective of the SEL-2431 (trace the wiring from interface Terminals E and U2 in *Figure B.13*, through the corresponding control wiring harness in *Figure 2.6*, through respective Terminals 4 and 2 of the VOLTAGES connector in *Figure C.1* and to the lower left corner of *Figure C.1*).

A polarity reversal for secondary voltage V_{S1} could also occur if all wiring in between *Figure B.1* and *Figure B.13* was normal, as shown, but the polarity mark at the top of the shunt winding (near the Terminal S) in *Figure B.1* was moved to the bottom of the shunt winding (near the Terminal SL) and the polarity mark remained where it was on the V_{S1} leads.

Global setting PT1POL (potential transformer 1 polarity, corresponding to secondary voltage V_{S1}) compensates for such polarity reversals—effectively adding a 180-degree phase shift to the V_{S1} voltage. Check the voltage

NOTE: In the **METER** command:
VL = normal load-side voltage
VS = normal source-side voltage.

NOTE: If polarity settings need to be changed from normal polarity (:= NORM), only one polarity setting must be changed (e.g., CTPOL := REV, PT1POL := NORM, and PT2POL := NORM is effectively the same as CTPOL := NORM, PT1POL := REV, and PT2POL := REV). Also, changing all three polarity settings (CTPOL, PT1POL, and PT2POL) to reverse (:= REV) is effectively the same as leaving them all normal (:= NORM).

regulator nameplate and instruction manual to determine the presence of a polarity reversal. Also use the **METER** command to check for a polarity reversal:

- In *Figure B.1*, both voltages V_{S1} and V_{S2} are available. If these voltages are closer to 180 degrees apart (than they are to 0 degrees apart), change the PT1POL setting (or PT2POL corresponding to V_{S2}) and the discrepancy will go away (they will appear closer to 0 degrees apart).
- In *Figure B.3* and *Figure B.4*, voltage V_{S1} (from the shunt winding) is on the load side. Check forward power flow—if it appears in the opposite direction than what is expected, a polarity reversal of voltage V_{S1} or the current can be suspected. Change the PT1POL setting (or CTPOL for the current) and forward power flow will be in the opposite direction from what it metered previously.

There might also be a similar voltage polarity reversal on V_{S2} . In this case, use Global setting PT2POL to compensate for this polarity reversal. Similarly, if there is a polarity reversal in the current transformer circuit, compensate for this using the CTPOL Global setting. Check all polarities of V_{S1} , V_{S2} , and I_L during commissioning of the voltage regulator and control. Use the metering of the SEL-2431 to aid commissioning.

This page intentionally left blank

Appendix C

Internal SEL-2431 Wiring and Extra I/O Connections

Internal Wiring

IMPORTANT: To provide complete fuse protection when connecting to an external source, it is recommended that a user-provided fuse (equivalent to the EXTERNAL 6A fuse) be installed in the "hot" lead of the externals source as shown in Figure C.1.

NOTE: Voltage measured at the **VOLTMETER** terminals can differ from VS or VL in metering because of voltage base normalization (see Figure B.1 through Figure B.4, with accompanying notes, and Appendix E: Voltage Base and Ratio Correction Transformer).

NOTE: The Analog Quantity VMETER reports the voltage at the voltmeter terminals.

NOTE: See **VOLTMETER** Test Terminals on page 3.9 for more information on the Internal switch in the Voltmeter circuit.

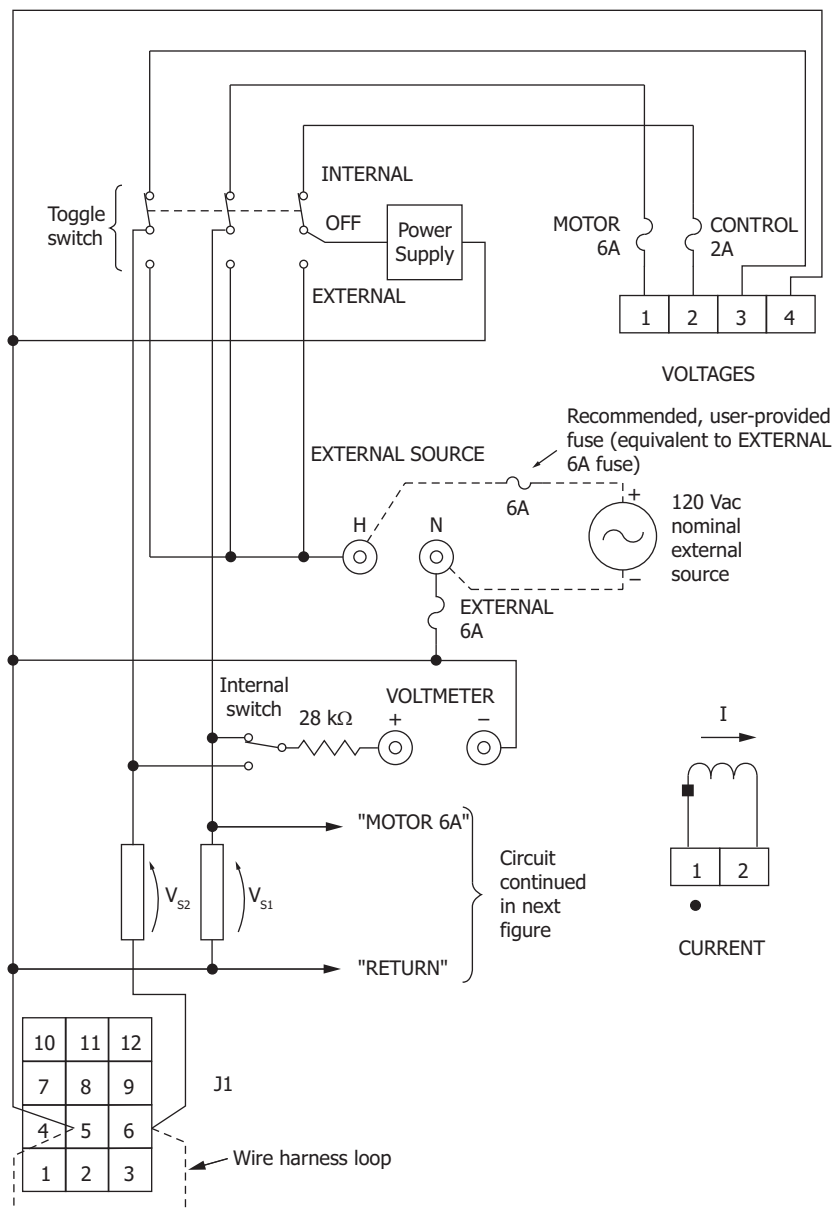

Figure C.1 SEL-2431 Internal Wiring—Voltage and Current Inputs

NOTE: See MOTOR CONTROL Toggle Switch on page 3.5 for more information on the Internal switch in the RAISE/LOWER circuit.

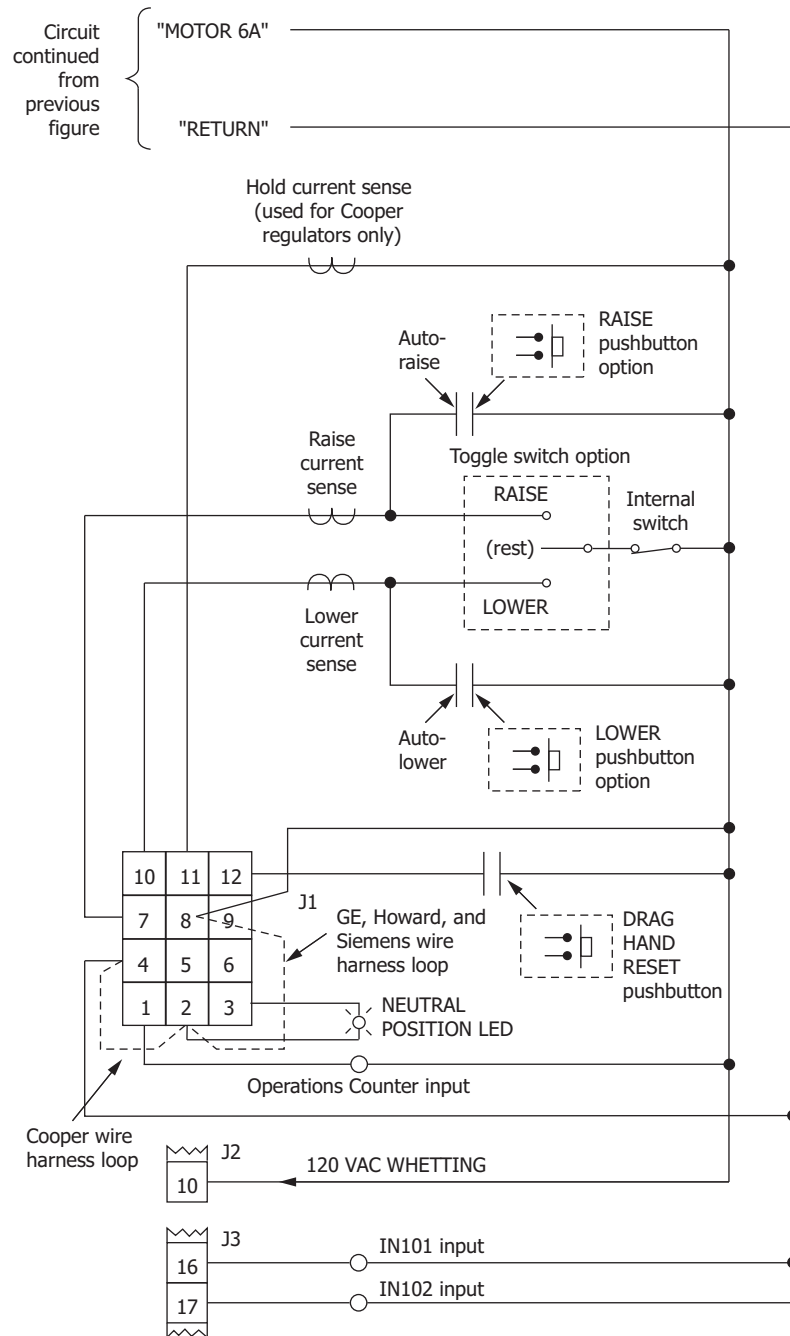

Figure C.2 SEL-2431 Internal Wiring—Raise/Lower Outputs and Other Inputs/Outputs

120 VAC WHETTING Output and Inputs IN101 and IN102

See *Figure C.2*. The 120 VAC WHETTING output (Terminal 10) on rear-panel connector J2 is provided only to wet inputs IN101 (Terminal 16) and IN102 (Terminal 17) on rear-panel connector J3. Any contact connected between the following terminal pairs (for the corresponding input):

- Terminal 10 (connector J2) and Terminal 16 (connector J3)
- Terminal 10 (connector J2) and Terminal 17 (connector J3)

must be a dry contact and not connected to any ground. These are the only connections allowed. Targeted uses for these two inputs are raise and lower commands from a remote source (e.g., SCADA). The 120 VAC WHETTING output is protected by the MOTOR 6A fuse (Figure C.1).

Output Contacts OUT101 Through OUT104

See Figure C.3. From the factory, output contact OUT101 comes as a Form B contact (normally closed) and is programmed as an alarm contact (contact is open when the SEL-2431 is OK/functional). Output contacts OUT102 through OUT104 come standard as Form A contacts (normally open). All the output contacts are programmable (see *Output Contacts* in Section 6: *Logic Functions* in the *SEL-2431 Voltage Regulator Control Instruction Manual*). See the output contact specifications in Section 1: *Introduction and Specifications* in the *SEL-2431 Voltage Regulator Control Instruction Manual*.

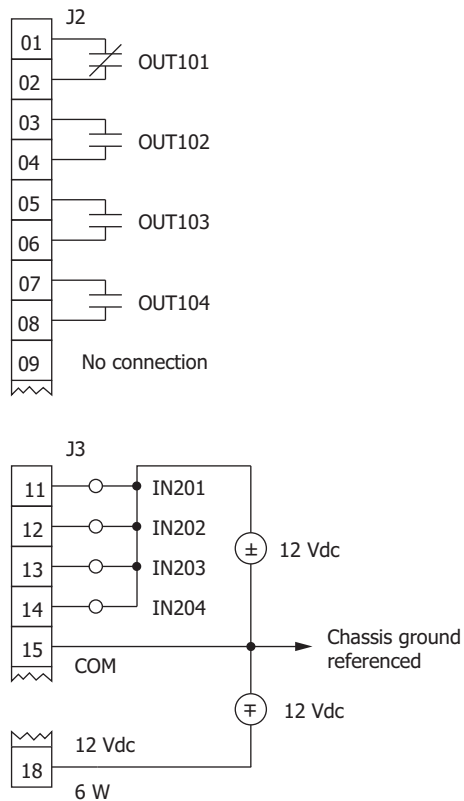

Figure C.3 SEL-2431 Internal Wiring—Other Inputs/Outputs on Connectors J2 and J3

Optoisolated Inputs IN201 Through IN204 (+12 Vdc)

See *Figure C.3*. Any contact connected between the following terminal pairs (for the corresponding input):

- ▶ Terminal 11 (connector J3) and Terminal 15 (connector J3)
- ▶ Terminal 12 (connector J3) and Terminal 15 (connector J3)
- ▶ Terminal 13 (connector J3) and Terminal 15 (connector J3)
- ▶ Terminal 14 (connector J3) and Terminal 15 (connector J3)

NOTE: Do not put more than two wires into Terminal 15 (connector J3). To effectively expand this COM (common) terminal, connect it to a separate terminal block with paralleled wiring points.

must be a dry contact and not connected to any ground. These are the only connections allowed. Notice that optoisolated inputs IN201 through IN204 are self-wetted by internal 12 Vdc.

12 Vdc (6 W) Output

See *Figure C.3*. This 12 Vdc output (Terminal 18) on rear-panel connector J3 provides 6 W continuous power. Any device connected to it must have its return connected to COM (Terminal 15) on rear-panel connector J3.

Appendix D

Circuit Grounding vs. Chassis Grounding

The following circuit grounding discussion is for informational/clarification purposes only. Circuit grounding provides a reference for all the interconnected 120 Vac circuitry of the SEL-2431 and the voltage regulator. The 120 Vac circuitry inside the SEL-2431 is not grounded (see *Figure C.1* and *Figure C.2*)—it is effectively grounded by its interconnection to the voltage regulator. Circuit grounding is provided by the voltage regulator manufacturer and subsequent correct installation of the voltage regulator.

Chassis grounding is a separate, most critical issue that has to be done first in the SEL-2431 installation procedure (see *Ground the Control Chassis on page 2.5*). Chassis grounding is not to be confused with circuit grounding, though both are likely connected to the same standard grounding point for a voltage regulator (e.g., ground stud inside the voltage regulator enclosure). Consult the voltage regulator nameplate and instruction manual for circuit grounding details.

Definitive Circuit Grounding for GE Voltage Regulators

Figure 2.9 and *Figure 2.10* show definitive circuit grounding (**GND** = voltage regulator enclosure ground) for a GE voltage regulator. As an example, look closer at *Figure 2.9* and its correspondence/connections to other figures/circuitry:

- *Figure B.7* (voltage, current, motor circuits, etc. from inside the voltage regulator)
- *Figure 2.9* (wiring harness, interconnected between the voltage regulator and the SEL-2431)
- *Figure C.1* and *Figure C.2* (SEL-2431 internal wiring)

In all these corresponding figures in this example, notice that the only circuit ground point is the previously mentioned **GND**. The same is true for *Figure 2.10* and corresponding *Figure B.8*, *Figure C.1*, and *Figure C.2*. In a GE voltage regulator control retrofit with the SEL-2431, the **GND** point in *Figure 2.9* and *Figure 2.10* must be connected up again to the new wiring harness, as shown in the figures.

Circuit Grounding for Other Voltage Regulators

The circuit grounding for other voltage regulators exists somewhere in the 120 Vac circuitry inside the voltage regulator or enclosure (see *Figure B.5* and *Figure B.6*—no circuit grounding is shown in these figures). Again, consult the voltage regulator nameplate and instruction manual for circuit grounding details.

This page intentionally left blank

Appendix E

Voltage Base and Ratio Correction Transformer

Voltage Base

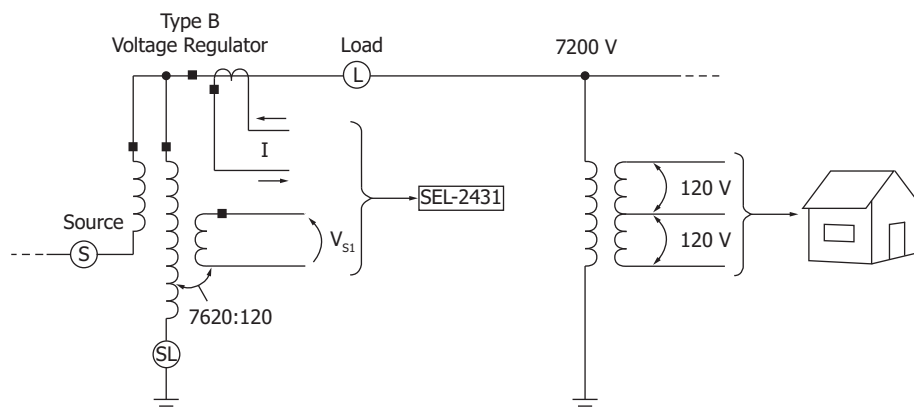

Figure E.1 Convert SEL-2431 Voltage Sensing to Customer Voltage Base

NOTE: The example in Figure E.1 uses a Type B voltage regulator, but the principles discussed are applicable to any voltage regulator type.

In Figure E.1, the distribution transformers on the nominal 7200 V (line-to-neutral) system have a turns ratio of 7200:120, contrasted to the effective potential transformer ratio of 7620:120 in the voltage regulator.

The voltage of most concern is the secondary voltage seen by the customer, not that seen by the voltage regulator. Ideally, the shunt-winding to utility-winding turns ratio in the voltage regulator would have been 7200:120, not 7620:120, however, only a 7620 V voltage regulator was available. Thus, the voltage into the SEL-2431 needs to be corrected to the customer voltage base. This is done with the following Global settings.

PT1PRIM := **7.62 kV** (primary rating of the effective potential transformer for voltage V_{S1})

PT1SEC := **120.0 V** (secondary rating of the effective potential transformer for voltage V_{S1})

BASE_PRI := **7.20 kV** (base primary voltage)

BASE_SEC := **120.0 V** (base secondary voltage)

The base conversion performed inside the SEL-2431 is:

$$\begin{aligned} V_{S1_BASE} &= V_{S1} \cdot (PT1PRIM/PT1SEC) \cdot (BASE_SEC/BASE_PRI) \\ &= V_{S1} \cdot 1.058 \end{aligned}$$

If a second voltage (V_{S2}) is connected to the SEL-2431, a similar base conversion is performed (like Global settings PT2PRIM and PT2SEC):

$$V_{S2_BASE} = V_{S2} \cdot (PT2PRIM/PT2SEC) \cdot (BASE_SEC/BASE_PRI)$$

These base voltages (V_{S1_BASE} and V_{S2_BASE}) are then used throughout the algorithms in the SEL-2431—in voltage regulation, metering, event reports, etc. All voltage related settings are made with respect to these base voltages.

The limiting conditions in these base voltage conversions are:

$$0.85 \leq [(PT1PRIM/PT1SEC) \cdot (BASE_SEC/BASE_PRI)] \leq 1.15 \text{ for } V_{S1_BASE}$$

$$0.85 \leq [(PT2PRIM/PT2SEC) \cdot (BASE_SEC/BASE_PRI)] \leq 1.15 \text{ for } V_{S2_BASE}$$

Ratio Correction Transformer (RCT)

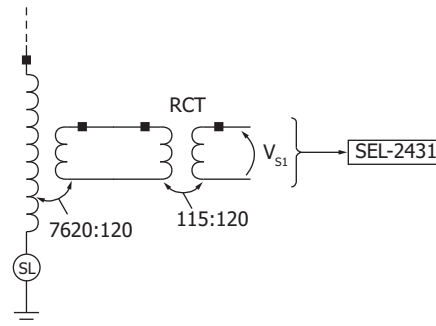

Figure E.2 RCT in SEL-2431 Voltage Sensing Path

If an RCT is used to bring the V_{S1} secondary voltage closer to the base voltage, it needs to be accounted for in the PT1PRIM and PT1SEC Global settings. *Figure E.2* is adapted from *Figure E.1*, with an RCT added in series. The effective overall potential transformer ratio is:

$$(7620/120) \cdot (115/120) = 60.85$$

Notice that 60.85 is close to the distribution transformer turns ratio of 60 (= 7200/120). If Global setting PT1PRIM is kept the same:

PT1PRIM := **7.62 kV** (primary rating of the effective potential transformer for voltage V_{S1})

then the corresponding secondary setting has to change:

PT1SEC := **125.2 V** (= 7620 V/60.85; secondary rating of the effective potential transformer for voltage V_{S1} in *Figure E.2*)

The base conversion performed inside the SEL-2431 is then:

$$\begin{aligned} V_{S1_BASE} &= V_{S1} \cdot (PT1PRIM/PT1SEC) \cdot (BASE_SEC/BASE_PRI) \\ &= V_{S1} \cdot 1.014 \end{aligned}$$

The factor of 1.014 (for *Figure E.2*) is much closer to 1.000 than the previous factor of 1.058 (for *Figure E.1*). Either way, with or without an RCT, the SEL-2431 can handle the base conversion, as long as the previously mentioned limiting conditions are met.

Appendix F

Voltage Regulator Control Enclosure Standard Features and Optional Accessories

The following are standard features and optional accessories when configuring the SEL-2431 Enclosure. Note that the enclosure has been designed to accommodate these accessories. If you are performing a retrofit, these accessories may not fit in the existing voltage regulator's enclosure.

Standard Features

Surge Suppression Accessory

The surge suppression accessory connects to the voltage regulator and the controller. The surge suppression accessory is used to increase surge immunity to 6 kV in the event of lightning strikes and other line disturbances. Install the surge suppression accessory if you have an SEL-2431 installed on a pole, in an area with high ground resistance, or in an area with frequent lightning strikes. The surge suppression accessory can be installed in retrofit applications if it fits in another manufacturer's enclosure.

Part Number	Description
915900455	SEL-2431 Surge Suppression Accessory

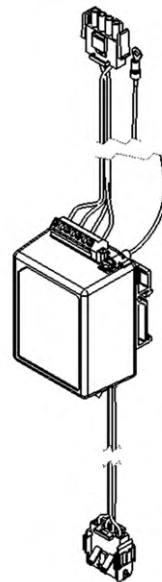

Figure F.1 Surge Suppression Accessory

Motor Capacitor Ready

The SEL-2431 Enclosure comes standard with a Motor Capacitor Ready option, which comes with a prewired bracket for transferring an existing enclosure-mounted capacitor to the SEL-2431 Enclosure or for installing a new capacitor in the enclosure.

Eaton/Cooper Fast Tap Diode

The Fast Tap Diode is included as an accessory with the enclosure that can be installed with Eaton/Cooper Voltage Regulators that use the IEEE 19-Pin Universal Interface Connector wiring. When installed, the fast tap diode improves tap tracking accuracy.

Optional Accessories

Ratio Correction Transformer (RCT)

The ratio correction transformer (RCT) is a field-installable or factory-installed optional accessory used to bring the secondary voltage closer to the 120 Vac base voltage. Refer to *Appendix E: Voltage Base and Ratio Correction Transformer* for details regarding configuring Global settings when using an RCT. You can order the SEL-2431 with either 1 or 2 RCTs for voltage correction of V_{S1} or both V_{S1} and V_{S2} . Refer to *Figure F.3* for additional details.

Field Installation Instructions

- Step 1. As detailed in the *Ground the Control Chassis on page 2.5*, make the chassis ground connection first.
- Step 2. Consult the voltage regulator instruction manuals about the need to de-energize voltage circuits and short out current circuits before any connections are made.
- Step 3. Move the **CONTROL POWER** toggle switch of the SEL-2431 to the **OFF** position.
- Step 4. Disconnect the **VOLTAGES** connector from the back of the SEL-2431.
- Step 5. Connect the **VOLTAGES** connector to the **J4** connector of the RCT wiring harness. Refer to *Figure F.2* for wiring details.
- Step 6. Connect the **J5** connector of the RCT wiring harness to the back of the SEL-2431.
- Step 7. To adjust the turns ratio of RCT1, remove the jumper between terminals TB3-6 and TB3-7. Install a new jumper wire between the TB3-7 and TB3-{1-6} terminals to apply the input V_{S1} voltage to the desired RCT tap. Move the TB3-6 output V_{S1} wire to the TB3-{1-6} terminal to adjust the output V_{S1} voltage to the RCT tap that will produce the desired turns ratio for correcting V_{S1} to a value closest to the 120 Vac voltage base. See *Table F.1* and *Table F.2* for reference to input V_{S1} and output V_{S1} tap positions based on the supplied input voltage or desired 120 Vac output voltage.
- Step 8. Note, if RCT2 is not installed, skip this step. To adjust the turns ratio of RCT2, remove the jumper between terminals TB3-16 and TB3-17. Install a new jumper wire between the TB3-17 and the TB3-{11-16} terminals to apply the input V_{S2} voltage to the desired RCT tap. Move the TB3-16 output V_{S2} wire to the TB3-{11-16} terminal to adjust the output V_{S2} voltage to the RCT tap that will produce the desired turns ratio for correcting V_{S2} to a value closest to the 120 Vac voltage base.

See *Table F.1* and *Table F.2* for reference to input V_{S1} and output V_{S1} tap positions based on the supplied input voltage or desired 120 Vac output voltage.

Factory-Installed Instructions

- Step 1. As detailed in the *Ground the Control Chassis on page 2.5*, make the chassis ground connection first.
- Step 2. Consult voltage regulator instruction manuals about the need to de-energize voltage circuits and short out current circuits before any connections are made.
- Step 3. Move the **CONTROL POWER** toggle switch of the SEL-2431 to the **OFF** position.
- Step 4. To adjust the turns ratio of the RCT1, remove the jumper between terminals TB3-6 and TB3-7. Install a new jumper wire between the TB3-7 and the TB3-{1-6} terminals to apply the input V_{S1} voltage to the desired RCT tap. Move the TB3-6 output V_{S1} wire to the TB3-{1-6} terminal to adjust the output V_{S1} voltage to the RCT tap that will produce the desired turns ratio for correcting V_{S1} to a value closest to the 120 Vac voltage base. See *Table F.1* and *Table F.2* for reference to input V_{S1} and output V_{S1} tap positions based on the supplied input voltage or desired 120 Vac output voltage.
- Step 5. Note, if RCT2 is not installed, skip this step. To adjust the turns ratio of RCT2, remove the jumper between terminals TB3-16 and TB3-17. Install a new jumper wire between TB3-17 and the TB3-{11-16} terminal to apply the input V_{S2} voltage to the desired RCT tap. Move the TB3-16 output V_{S2} wire to the TB3-{11-16} terminal to adjust the output V_{S2} voltage to the RCT tap that will produce the desired turns ratio for correcting V_{S2} to a value closest to the 120 Vac voltage base. See *Table F.1* and *Table F.2* for reference to input V_{S1} and output V_{S1} tap positions based on the supplied input voltage or desired 120 Vac output voltage.

NOTE: For adjusting voltages, see Table F.1 and Table F.2 for input and output tap assignments.

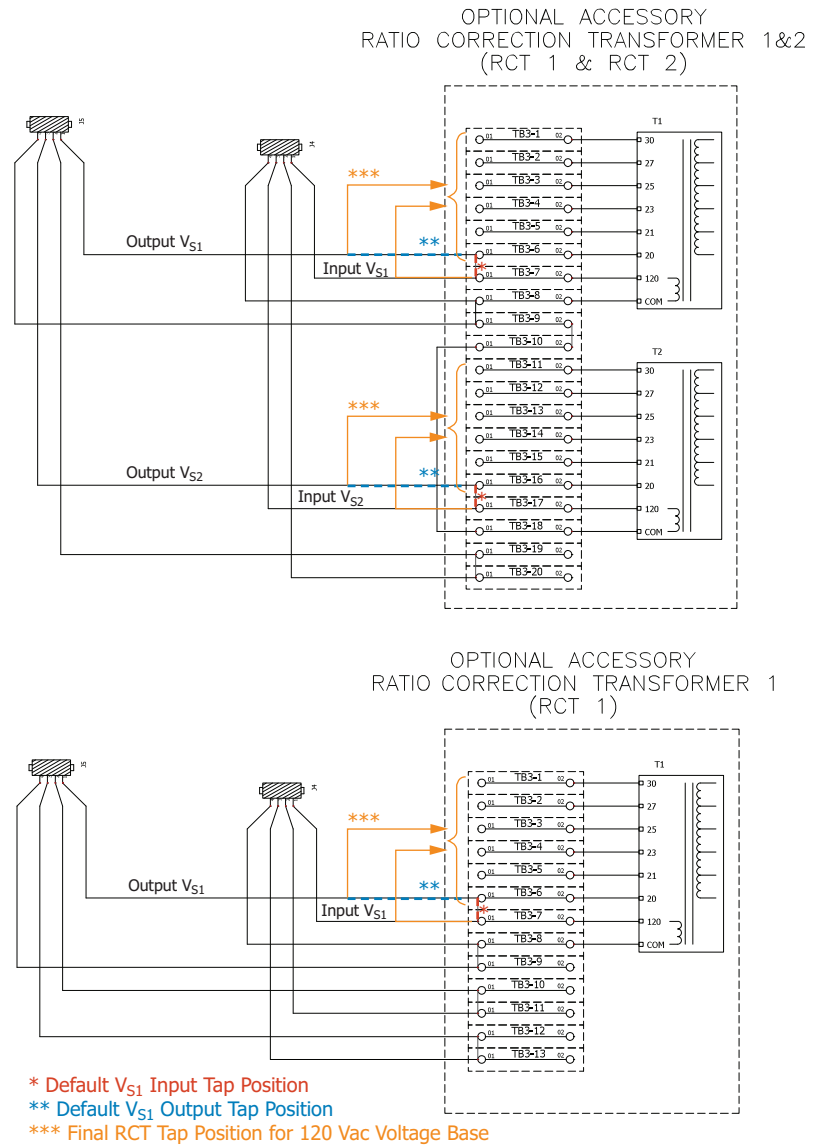

Figure F.2 RCT Wiring Diagram

Use Table F.1 and Table F.2 to determine the correct input/output taps for correcting the V_{S1}/V_{S2} input voltages when using ratio correction transformers.

Table F.1 assumes a per-unit (pu) input voltage and displays the resultant output ratio at the V_{S1}/V_{S2} RCT input tap.

Table F.2 assumes a desired 120 Vac output and expects the output from the voltage regulator PT to be represented at the V_{S1}/V_{S2} input tap.

RCT Example

Note that this example uses the same system voltage (7200 V [line-to-neutral]) and PT ratio (7620:120) in the voltage regulator as the example given in Appendix E: Voltage Base and Ratio Correction Transformer.

A winding turns ratio of 7620:120 and a system voltage of 7200 (line-to-neutral) results in an V_{S1} input voltage of 113.39 Vac.

Use the ratio correction transformers to get this V_{S1} input voltage closer to the system base voltage of 120 Vac. Because this example has a V_{S1} input voltage of 113.39 Vac, use Table F.2 to determine the taps you must wire the RCT to

in order to get the desired 120 Vac output voltage. Find the value closest to 113.39, which is 113.4 at the intersection of Input V_{S1}/V_{S2} Tap 20 and Output V_{S1}/V_{S2} Tap 27. So, to correct the V_{S1} voltage, connect the V_{S1} input jumper wire to Tap 20 by making the connection at TB3-6, and connect the V_{S1} output wire to Tap 27 by making the connection at TB3-2.

Note that you can use the RCT in conjunction with the setting described in *Appendix E: Voltage Base and Ratio Correction Transformer* to calibrate the secondary voltage to the customer voltage base.

Table F.1 RCT Connection for Effective Output Correction Ratio

Input V_{S1}/V_{S2} Tap	Output V_{S1}/V_{S2} Tap					
	20	21	23	25	27	30
20	1.000	1.009	1.026	1.041	1.059	1.083
21	0.991	1.000	1.017	1.033	1.050	1.074
23	0.974	0.983	1.000	1.016	1.033	1.057
25	0.959	0.967	0.984	1.000	1.017	1.041
27	0.941	0.950	0.967	0.983	1.000	1.024
30	0.917	0.926	0.943	0.959	0.976	1.000

Table F.2 RCT Connection for 120 Vac Output Voltage

Input V_{S1}/V_{S2} Tap	Output V_{S1}/V_{S2} Tap					
	20	21	23	25	27	30
20	120.0	119.0	117.0	115.2	113.4	110.8
21	121.0	120.0	118.0	116.2	114.3	111.7
23	123.2	122.1	120.0	118.2	116.2	113.5
25	125.2	124.1	121.9	120.0	118.0	115.2
27	127.5	126.3	124.1	122.1	120.0	117.2
30	130.8	129.6	127.2	125.2	123.0	120.0

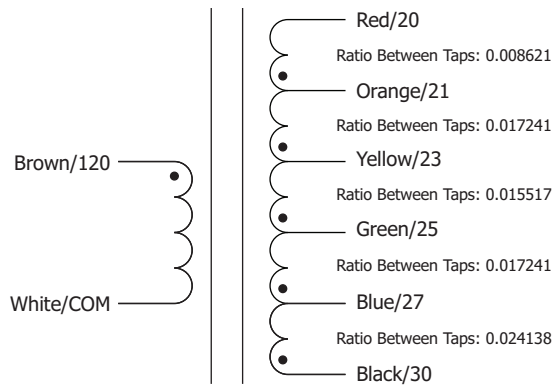

Figure F.3 RCT Schematic

SEL-9322 15 Vdc Power Supply

The SEL-9322 15 Vdc Power Supply is an ac-to-dc or dc-to-ac converter designed for harsh physical and electrical environments. The SEL-9322 provides a nominal 15 Vdc at as high as 1 A to power communications or instrumentation devices. When configuring the SEL-2431 Enclosure with an SEL-2401 or SEL-9322, the SEL-9322 is required to meet load requirements

because the SEL-2401 internal auxiliary power supply is not rated to supply these devices. See the *SEL-9322 Instruction Manual* for additional product details.

SEL-2401 Satellite-Synchronized Clock

The SEL-2431 Enclosure is available with the SEL-2401 Satellite-Synchronized Clock. Enclosures ordered with the SEL-2401 are equipped with a TNC-type surge suppressor wired to the bottom of the enclosure with a coaxial cable. The SEL-2401 IRIG-B output is connected to the SEL-734B IRIG-B input. An antenna kit is included in the box, which contains a low-profile antenna, a mounting bracket, and a coaxial cable. See the *SEL-2401 Instruction Manual* for additional product details.

SEL-3061 Cellular Router

The SEL-2431 Enclosure is available with the SEL-3061 Cellular Router. When the enclosure is ordered with the SEL-3061, SEL installs two N-Type surge suppressors on the bottom of the enclosure to allow connection of two antennas. The antennas and cables are sold separately. See the *SEL-3061 Instruction Manual* for additional product details.

Enclosure Door Switch

The SEL-2431 Enclosure can be configured with an optional door switch that is wired to a digital input on the SEL-2401. The digital input changes state when the door is opened and the indication is mapped to the DNP binary inputs for SCADA.

Eaton/Cooper 12-Conductor Interface

The Eaton/Cooper 12-Conductor Control Wiring Harness is an optional accessory that includes a cable harness that has one side wired to the external/customer side of the 19-Pin Terminal (see *Figure 2.16*) and the other side includes a quick disconnect connector for connecting to the 12-Conductor Voltage Regulator Control Cable. Note, when the Eaton/Cooper Interface 12-Conductor is selected, the unit comes with the Fast Tap Diode installed and wired from the factory.

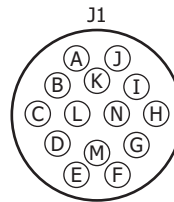

View from pin insertion side.

Figure F.4 Eaton/Cooper 12-Conductor

Table F.3 Eaton/Cooper 12-Conductor Wiring

Connector Pin	Function	Termination Point
J1-A	Voltage V1	V1
J1-B	Ground	G
J1-C	CT Negative Polarity	C1
J1-D	CT Positive Polarity	C2
J1-E	Holding Switch	HS
J1-F	Raise	R1
J1-G	Voltage V6	V6
J1-H	Neutral Position LED	NL
J1-I	Lower	L1

Table F.3 Eaton/Cooper 12-Conductor Wiring

Connector Pin	Function	Termination Point
J1-J	Draghand Reset	DHR
J1-K	Not Connected	N/A
J1-L	Capacitor	MC2
J1-M	Not Connected	N/A
J1-N	Capacitor	MC1

IEEE/IEC 19-Pin Universal Interface

The IEEE/IEC 19-pin universal interface harness and circular connector is an optional accessory for the SEL-2431. One side of the harness is wired to the user side of the 19-pin terminal block (see *Figure 2.16*). The box-mounted circular connector is attached to the bottom of the enclosure as shown in *Figure F.6*. This connector can interface with voltage regulators that implement the 19-pin universal interface in accordance with IEC 60076-21:2018 and IEEE Std C57.15-2017.

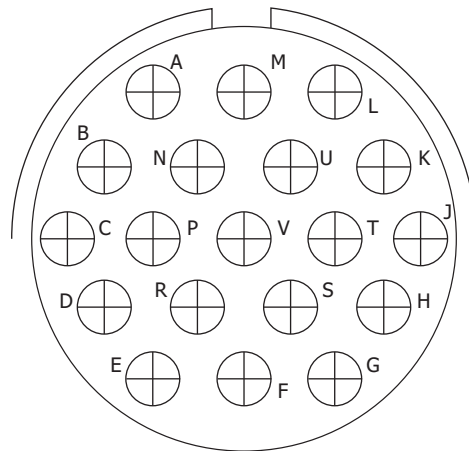

View from the pin insertion side.

Figure F.5 19-Pin Universal Interface Connector

Table F.4 19-Pin Universal Interface Wiring

NOTE: Cooper/Eaton voltage regulators use a neutral feedback circuit when closing to phase. All regulators except Cooper/Eaton use neutral feedback circuitry that closes to ground. For Cooper/Eaton voltage regulators, connect J1-3 to TBI-13, for all others connect J1-3 to TBI-3.

NOTE: Only Cooper/Eaton voltage regulators require a fast tap diode accessory. The accessory must be installed between ports TBI-23 and TBI-7, and between ports TBI-24 and TBI-8. If a Cooper/Eaton voltage regulator is not installed in the SEL-2431, use wire jumpers instead of the fast tap diode accessory.

NOTE: GE voltage regulators have multiple voltage connection leads depending on the system voltage required. Refer to the voltage regulator PT nameplate to learn the required system voltage for your device. Connect only one source voltage lead to TBI-14 (VS) and only one load voltage lead to TBI-6 (VL).

Terminal	Function
A	Ground
B	Operations counter contact closing to ground
C	Neutral light switch contact closing to ground (used by all excluding Cooper/Eaton)
D	CT secondary (polarity)
E	CT secondary (neutral)
F	Voltage supply (“L” bushing)
G	Raise circuitry from tap-changer motor
H	Lower circuitry from tap-changer motor
J	Raise circuitry from tap-changer motor capacitor
K	Lower circuitry from tap-changer motor capacitor
L	Drag hand reset of mechanical position indicator
M	Feedback circuitry of raise and lower circuitry of tap-changer motor
N	Neutral Light switch contact closing to phase (Cooper/Eaton only)
P	Voltage supply (“S” bushing)
R	Auxiliary voltage supply
S	OPEN (All excluding GE) / Voltage connection lead 20 (GE)
T	OPEN (All excluding GE) / Voltage connection lead 21 (GE)
U	OPEN (All excluding GE) / Voltage connection lead 22 (GE)
V	OPEN (All excluding GE) / Voltage connection lead 23 (GE)

Figure F.6 shows how an IEEE/IEC 19-pin universal interface connector is wired to port TBI.

SEL-2431 Wiring Cross Reference

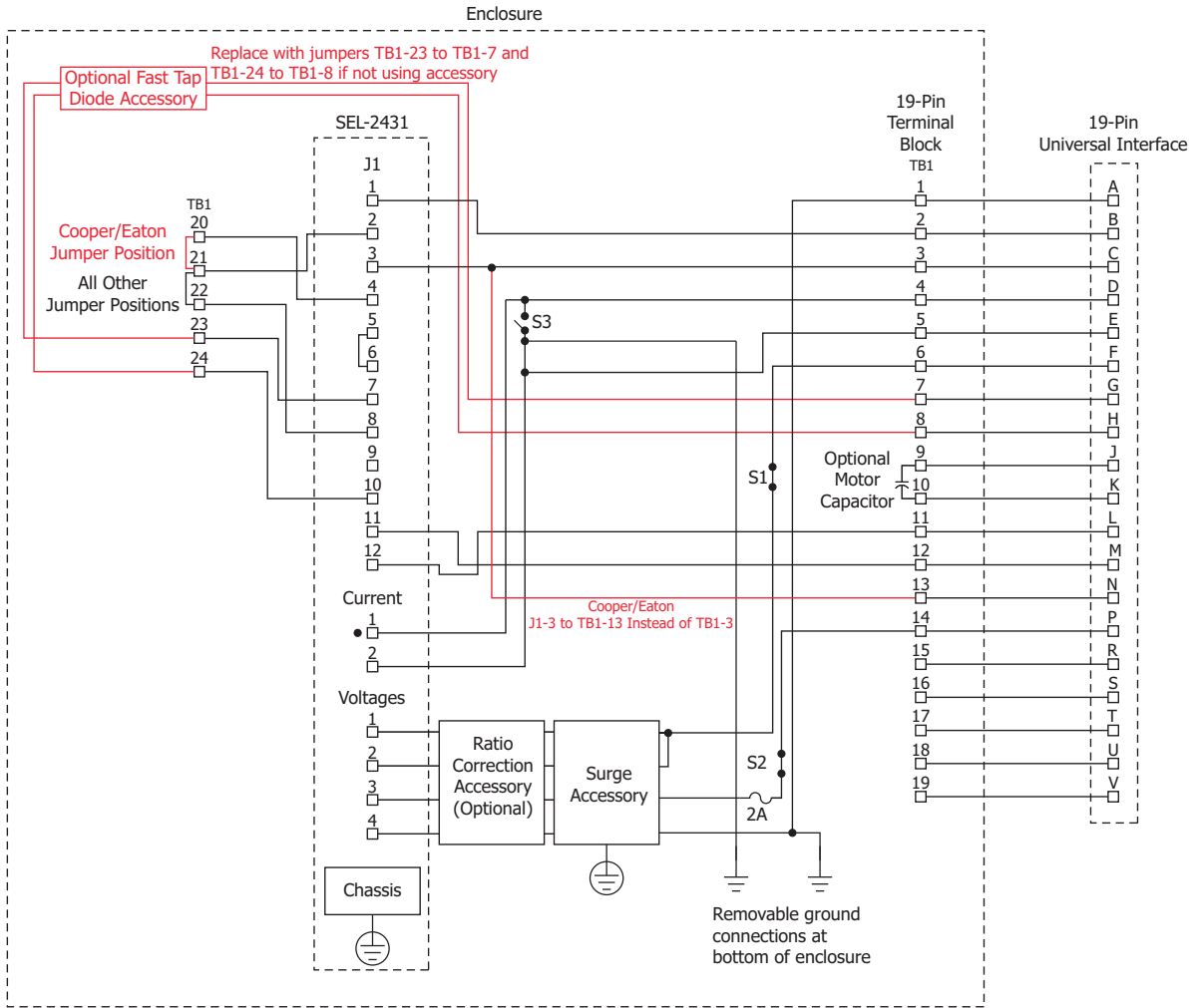
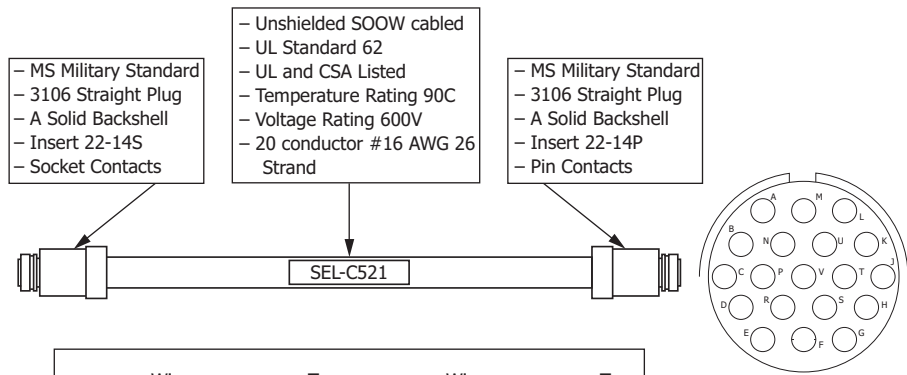

Figure F.6 19-Pin Universal Interface Wiring Diagram

Cable C521

Cable SEL-C521 extends the IEEE/IEC 19-pin universal interface accessory to the voltage regulator which also has the IEEE/IEC 19-pin universal interface.



Wire	To	Wire	To
Black w/ White Stripe	E	Blue	T
Red w/ White Stripe	F	Black w/ Red Stripe	J
Green w/ White Stripe	G	Green w/ Black Stripe	B
Blue w/ Black Stripe	D	Red w/ Green Stripe	N
Green	R	White w/ Black Stripe	U
Orange	S	White w/ Red Stripe	K
Blue w/ White Stripe	H	Red w/ Black Stripe	A
Orange w/ Black Stripe	C	Blue w/ Red Stripe	M
Red	P	Orange w/ Red Stripe	L
Black	V		

View from rear face of pin insert or front face of socket insert.

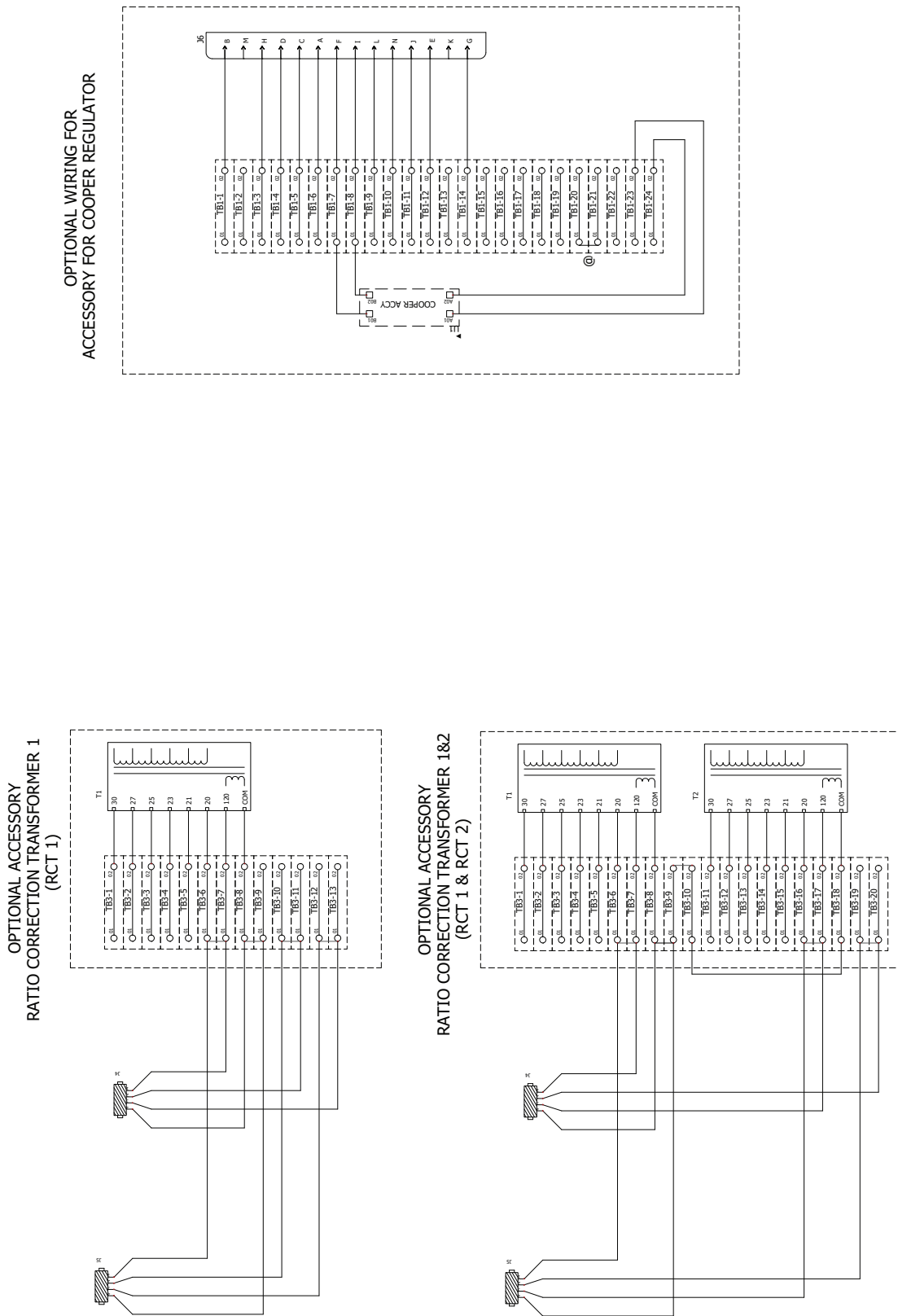

Figure G.2 Voltage Regulator Control Enclosure's RCT Point-to-Point Wiring Diagram

2431 VOLTAGE REGULATOR CONTROL (A1)

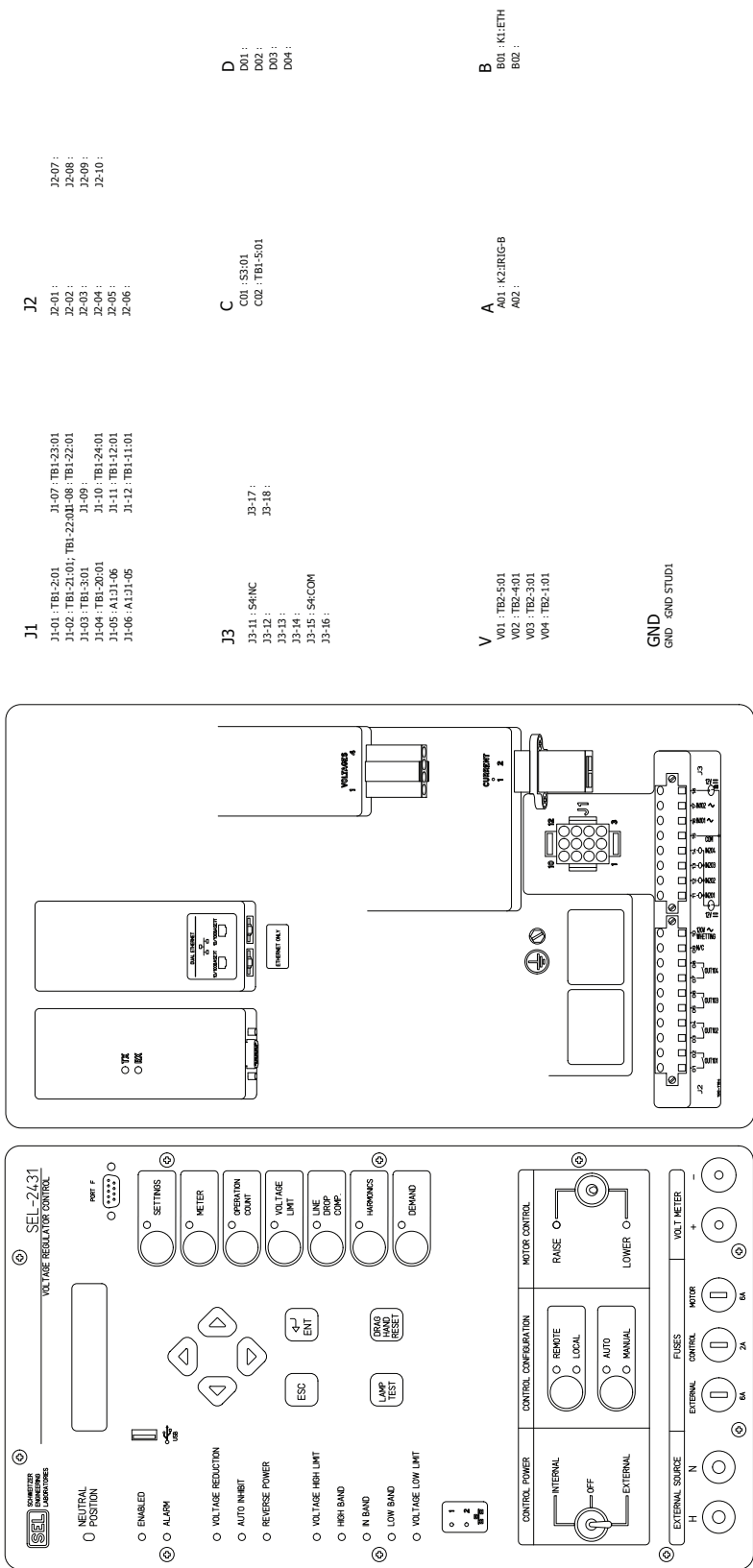

Figure G.3 Voltage Regulator Control Enclosure Point-to-Point Wiring Diagram



SCHWEITZER ENGINEERING LABORATORIES, INC.

2350 NE Hopkins Court • Pullman, WA 99163-5603 U.S.A.

Phone: +1.509.332.1890 • Fax: +1.509.332.7990

selinc.com • info@selinc.com