

Protecting Power Transformers From Common Adverse Conditions

Ali Kazemi and Casper Labuschagne
Schweitzer Engineering Laboratories, Inc.

Revised edition released June 2026

Originally presented at the
32nd Annual Western Protective Relay Conference, October 2005

Protecting Power Transformers From Common Adverse Conditions

Ali Kazemi, *Schweitzer Engineering Laboratories, Inc.*
Casper Labuschagne, *Schweitzer Engineering Laboratories, Inc.*

Abstract—Power transformers of various size and configuration are applied throughout the power system. These transformers play an important role in power delivery and the integrity of the power system network as a whole.

Power transformers have operating limits beyond which transformer loss of life can occur. This paper examines the adverse conditions to which a power transformer might be subjected. Our discussion includes transformer overload, through-fault, and overexcitation protection. We discuss each operating condition and its effect on the power transformer, and provide a solution in the protection scheme for each operating condition.

I. INTRODUCTION

In general, the main concern with transformer protection is protecting the transformer against internal faults and ensuring security of the protection scheme for external faults. System conditions that indirectly affect transformers often receive less emphasis when transformer protection is specified.

Overloading power transformers beyond the nameplate rating can cause a rise in temperature of both transformer oil and windings. If the winding temperature rise exceeds the transformer limits, the insulation will deteriorate and may fail prematurely. Prolonged thermal heating weakens the insulation over time, resulting in accelerated transformer loss-of-life.

Power system faults external to the transformer zone can cause high levels of current flowing through the transformer. Through-fault currents create forces within the transformer that can eventually weaken the winding integrity.

A comprehensive transformer protection scheme needs to include protection against transformer overload, through-fault, and overexcitation, as well as protection for internal faults.

This paper focuses on liquid-immersed transformers because the majority of medium and high-voltage transformers are of this type.

II. POWER TRANSFORMER CAPABILITY LIMITS

A power transformer consists of a set of windings around a magnetic core. The windings are insulated from each other and the core. Operational stresses can cause failure of the transformer winding, insulation, and core.

The power transformer windings and magnetic core are subject to a number of different forces during operation [3]:

- Expansion and contraction caused by thermal cycling.
- Vibration caused by flux in the core changing direction every half cycle.

- Localized heating caused by eddy currents in parts of the winding, induced by magnetic flux.
- Impact forces caused by through-fault currents.
- Thermal heating caused by overloading.

ANSI/IEEE standards [1] [2] provide operating limits for power transformers. Initially, these operating limits only considered the thermal effects of transformer overload. Later, the capability limit was changed to include the mechanical effect of higher fault currents through the transformer. Power transformer through-faults produce physical forces that cause insulation compression, insulation wear, and friction-induced displacement in the winding. These effects are cumulative and should be considered over the life of the transformer.

Table I shows four categories [1] for liquid-immersed power transformers, based on the transformer nameplate rating.

TABLE I
TRANSFORMER CATEGORIES

Category	Single Phase KVA	Three Phase KVA
I	5 to 500	15 to 500
II	501 to 1667	501 to 5000
III	1668 to 10000	5001 to 30000
IV	Above 10000	Above 30000

To provide a more comprehensive representation of the long-term effects of system conditions on power transformers, each category includes through-fault capability limits, which are a function of the maximum current through the transformer. The maximum current (in per unit [p.u.] of the transformer base rating) is calculated based on the transformer short-circuit impedance for category I and II transformers. Maximum current calculation for category III and IV transformers is based on the overall impedance of the transformer short-circuit impedance and the system impedance.

A. Category I Transformers

Fig. 1 shows the through-fault capability limit curve for category I transformers. The curve reflects both thermal and mechanical considerations. For short-circuit currents at 25–40 times the base current, the I^2t limit of 1250 defines the curve, where I is the symmetrical fault current in multiples of the transformer base current and t is in seconds.

Current (I) is based on the transformer's per-unit short circuit impedance. A transformer with 4 percent impedance will have a maximum short circuit current of 25 p.u. (1/0.04),

which results in a time of 2 seconds ($1250/25^2$) for its through-fault capability limit.

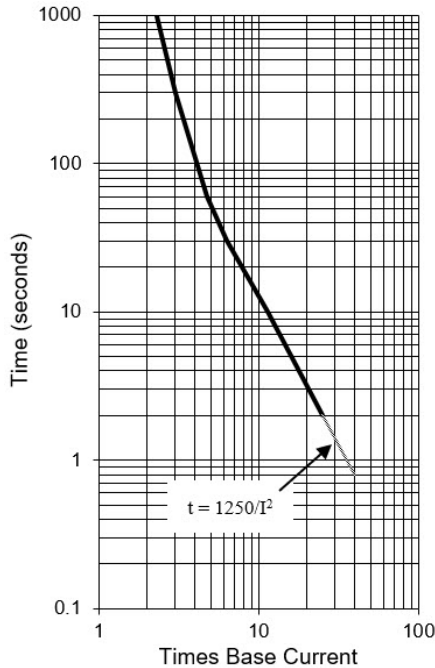

Fig. 1. Through-Fault Capability limit curve for Liquid-Immersed Category I Transformers

B. Category II and III Transformers

For Category II and III transformers, the IEEE standard provides an additional through-fault capability limit curve. The additional curve takes into account the fault frequency that the transformer is subjected to throughout its entire life. In general, use a frequent-fault curve if fault frequency is higher than ten through-faults for category II transformers and higher than five through-faults for category III transformers. Fault frequency is considered over the life of the transformer.

Fig. 2 represents the through-fault capability limit curve for category II and III transformers that experience infrequent faults. The curve is limited to two seconds.

To acknowledge the cumulative nature of damage caused by through-faults, the standard supplements the through-fault capability limit curve to reflect mechanical damage. It calculates the I^2t curve based on the actual transformer impedance. For category II transformers, consider the mechanical duty for fault currents higher than 70 percent of maximum possible short-circuit current. For category III and IV transformers, consider mechanical duty for through-fault currents higher than 50 percent of maximum possible short-circuit current.

Fig. 3 shows the through-fault capability limit curve for a category II transformer with 7 percent impedance. The I^2t calculation is at maximum short-circuit current for a time of 2 seconds.

For a transformer with 7 percent impedance, I^2t calculates at 408 as shown below:

$$I = 1/0.07 = 14.29; \text{ this is the maximum short-circuit current in p.u. of transformer base rating}$$

$$I^2t = (14.29)^2 \cdot 2 = 408$$

The lower portion of the curve is 70 percent of maximum short-circuit current and the I^2t calculated above.

$$I = 0.7 \cdot 14.29 = 10$$

$$t = 408/(I)^2 = 4.08$$

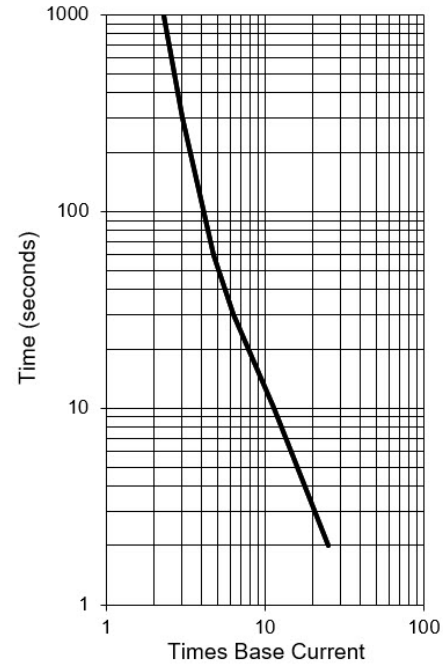

Fig. 2. Through-Fault Capability Limit Curve for Liquid-Immersed Category II and III Transformers with Infrequent Faults

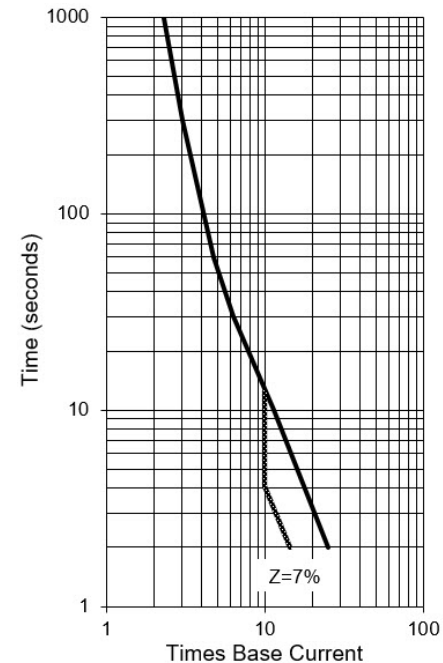

Fig. 3. Through-Fault Capability Limit Curve for Liquid-Immersed Category II Transformers with Frequent Faults

C. Category IV Transformers

Fig. 4 shows the through-fault capability limit curve for category IV transformers. The curve represents both the frequent and the infrequent fault occurrences. For category III and IV transformers the mechanical duty limit curve starts at 50 percent of the short circuit current.

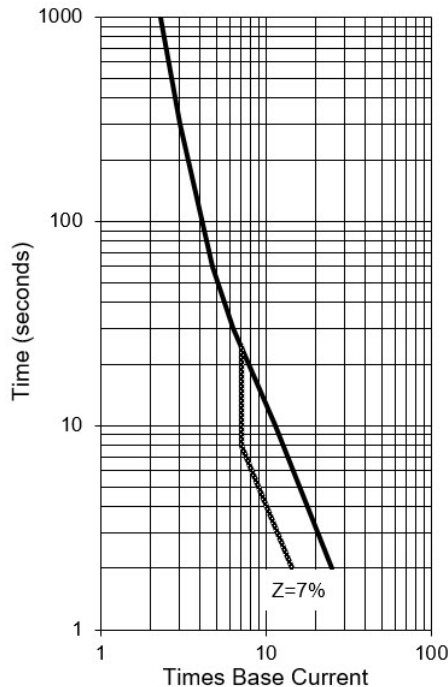

Fig. 4. Through-Fault Capability Limit Curve for Liquid-Immersed Category IV Transformers

D. Protection Considerations

After determining the proper through-fault capability limit curve for a particular transformer, select a time-overcurrent characteristic to coordinate with the through-fault capability limit curve.

In distribution transformer applications where a number of feeders are connected to the low-voltage bus, the feeder relays become the first line of defense. IEEE Standard C37.91 recommends [3] setting the inverse time-overcurrent characteristic of the feeder relays to coordinate with the through-fault capability limit curve of the transformer, as shown in Fig. 5.

Coordinating an overcurrent element with an I^2t thermal element requires further consideration. Although the extremely inverse time-overcurrent characteristic of the overcurrent relay seems to emulate the shape of the thermal curve, the coordination is only valid for a fixed initial overcurrent condition [4]. Once an overload or through-fault condition causes the transformer winding temperature to rise, coordination between the overcurrent relay and the thermal element is no longer valid. In this situation, the overcurrent relay does not prevent thermal damage caused by cyclic overloads.

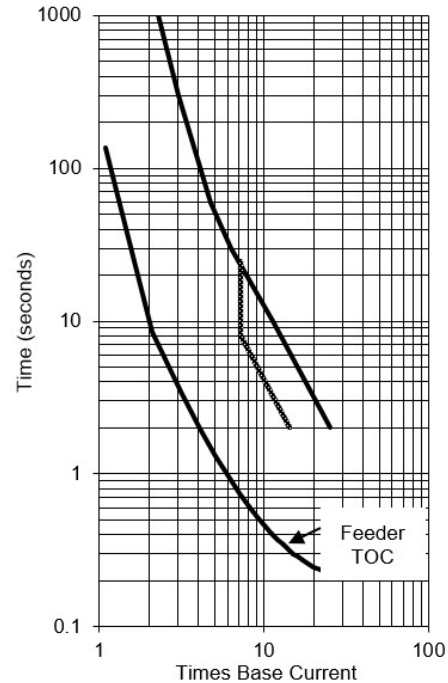

Fig. 5. TOC Coordination with Category IV Transformer Through-Fault Capability Limit Curve

III. TRANSFORMER OVERLOAD

A. Overcurrent vs. Overload

For this paper, we define overcurrent as current flowing through the transformer resulting from faults on the power system. Fault currents that do not include ground are generally in excess of four times full-load current; fault currents that include ground can be below the full-load current depending on the system grounding method. Overcurrent conditions are typically short in duration (less than two seconds) because protection relays usually operate to isolate the faults from the power system.

Overload, by contrast, is current drawn by load, a load current in excess of the transformer nameplate rating. IEEE standard [5] lists nine risks when loading large transformers beyond nameplate ratings. In summary, loading large power transformers beyond nameplate ratings can result in reduced dielectric integrity, thermal runaway condition (extreme case) of the contacts of the tap changer, and reduced mechanical strength in insulation of conductors and the transformer structure.

Three factors, namely water, oxygen, and heat, determine the insulation (cellulose) life of a transformer. Filters and other oil preservation systems control the water and oxygen content in the insulation, but heat is essentially a function of the ambient temperature and the load current. Current increases the hottest-spot temperature (and the oil temperature), and thereby decreases the insulation life span.

Equation (1) is used as an indication of the insulation-aging effect of overloading a transformer.

$$\%LOL = \frac{H}{ILIFE} \cdot 100 \quad (1)$$

where:

%LOL percentage loss-of-life

H = Time in hours

ILIFE = Insulation life

In general, assume the insulation life of a transformer to be 180,000 hours and the rated hottest-spot temperature to be 110°C. Therefore, a transformer operating at the rated hottest-spot temperature of 110°C for 24 hours ages at a rate of 0.0133 percent, calculated as follows:

$$\%LOL = \frac{24 \cdot 100}{180,000} = 0.01333\%$$

However, overloading the transformer decreases the insulation life span exponentially. To relate the hottest-spot temperature to the per-unit insulation life, we calculate FAA, the Aging Acceleration Factor. Equation (2) shows the calculation for FAA, with 15,000 being a design constant.

$$FAA = \exp\left[\frac{15,000}{383} - \frac{15,000}{\theta_H + 273}\right] \quad (2)$$

where:

θ_H is the calculated hottest-spot temperature

An FAA factor of 10 means that, at the present hottest-spot temperature, the transformer insulation ages 10 times faster than the per-unit life over a given time interval. In terms of temperature, an FAA of 10 corresponds to a hottest-spot temperature of approximately 135°C.

B. Ambient Temperature

Excessive load current alone may not result in damage to the transformer if the absolute temperature of the windings and transformer oil remains within specified limits. Transformer ratings are based on a 24-hour average ambient temperature of 30°C (86°F). Note that the ambient temperature is the air in contact with the radiators or heat exchangers. Table II shows the increase or decrease from rated kVA for other than average daily ambient temperature of 30°C.

TABLE II
TRANSFORMER LOADING WITH TEMPERATURE AS A FACTOR

Type of cooling	Percentage of kVA rating	
	Decrease load for each °C higher than 30°C	Increase load for each °C lower than 30°C
Self-cooled (OA)	1.5	1.0
Water-cooled (OW)	1.5	1.0
Forced-air cooled (OA/FA, OA/FA/FA)	1.0	0.75
Forced-oil, -air, -water, -cooled (FOA, FOW, and OA/FOA/FOA)	1.0	0.75

C. Thermal Models Including Ambient Temperature

More sophisticated transformer thermal models [5] use load current as well as the ambient temperature to calculate Top-Oil temperature and hottest-spot temperature.

To calculate the absolute Top-Oil temperature and hottest-spot temperature, the model adds the calculated Top-Oil and hottest-spot temperatures to the measured ambient temperature (subtract for a temperature drop). When the ambient temperature is not available, or communication with the device that supplies the ambient temperature information is lost, the thermal model uses a fixed value as reference for the ambient temperature. However, using a fixed value instead of the actual ambient temperature as reference means that the model cannot indicate whether actual damage will occur at any particular level of overload.

D. Thermal Models Excluding Ambient Temperature

Although less accurate, models without direct ambient temperature can still provide useful information as to the temperature rise of the transformer oil when constant current flows. These models project the temperature rise within the transformer as a function of (constant) load current flowing through the transformer. For example, looking at the manufacturers' literature, we see that a hypothetical transformer has a time constant (TC) of one hour. Using Equation (3), we calculate that the transformer will reach steady-state temperature after five hours (five time constants) when constant full-load current flows.

$$\theta(t) = I_{FL} \left(1 - e^{-\frac{t}{TC}} \right) \quad (3)$$

where:

θ = Transformer oil temperature

I_{FL} = Transformer full-load current

TC = Time constant

t = Time in seconds

Furthermore, we can calculate that, if full-load current flows for one hour, the temperature is approximately 63 percent of the final value (solid curve in Fig. 6). However, we see that, if we overload the transformer by 20 percent, the temperature is approximately 75 percent of the final value after one hour (dashed curve in Fig. 6).

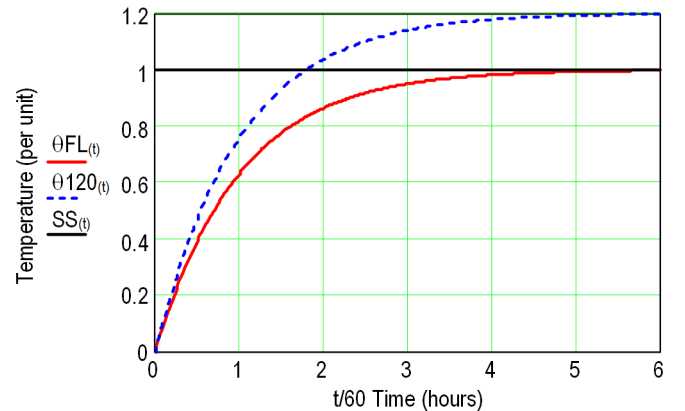

Fig. 6. Oil Temperature Curves For Full-Load Current and Twenty Percent Overload Current

We now use this information (75 percent) as a warning signal that we are overloading the transformer. Because we do

not measure the ambient temperature, we cannot determine whether actual damage will occur at this level of overload.

E. Cooling System Efficiency

Many installations provide remote thermal devices (RTDs) for both ambient temperature and oil temperature measurement. Measuring both ambient temperature and oil temperature provides a method for comparing calculated oil-temperature values to measured oil-temperature values. Ideally, calculated oil-temperature values and measured oil-temperature values should be the same. Differences between calculated and measured values can indicate that the cooling system is not performing at full efficiency, resulting from such problems as defective fan motors. At first installations, a practical approach is to use the difference between calculated and measured values to fine-tune setting of transformer constants. Because transformer constants are not always available at the time of commissioning, some constants may have been assumed during the setting process. Once we establish that the cooling system is in good working order, we can assume that the difference between calculated and measured values is the result of incorrect transformer constant settings. After adjusting the transformer constants to the point where calculated and measured values are the same, we can now attribute any subsequent deviations in calculated and measured values can now be attributed to lower efficiency of the cooling system.

F. Thermal Protection Application Example

The idea behind a thermal element is to provide the system operator with meaningful data about the state of the transformer. The thermal element provides data for determining whether a transformer can withstand further short-term or long-term overloads without sacrificing transformer loss-of-life. This information is a function of the ambient temperature, transformer-loading history, present loading condition, and cooling system efficiency.

The inputs to the transformer thermal monitor include transformer Top-Oil temperature, ambient temperature, and transformer loading indication provided through either the high-side or the low-side current transformers.

Fig. 7 shows a one-line diagram for a transformer protection relay providing differential protection and thermal monitoring for the transformer. RTDs provide Top Oil and ambient temperatures to the relay.

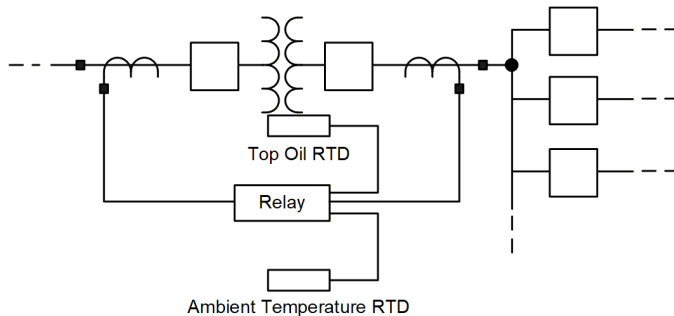

Fig. 7. Transformer Protection Relay With Connected RTDs for Thermal Monitoring

The thermal element provides the transformer thermal status both as alarm points and as a report. The alarm points indicate whether a measured value exceeds a settable threshold. These alarm points might include Top-Oil Temperature, Hottest-spot Temperature, Aging Acceleration Factor, Daily Rate of Loss-of-Life, and Total Loss-of-Life.

The thermal element report is shown in Fig. 8.

XFNR 1	Date: 05/09/16	Time: 07:58:27.241
STATION A		
Transformer 1		
Thermal Element Condition	:	Normal
Load(Per Unit)	:	0.96
In Service Cooling Stage	:	1
Ambient (deg. C)	:	15.0
Calculated Top Oil (deg. C)	:	23.4
Measured Top Oil (deg. C)	:	25
Winding Hot Spot (deg. C)	:	46.7
Aging Acceleration Factor, FAA	:	0.01
Rate of LOL (%/day)	:	0.01
Total Accumulated LOL (%)	:	0.20
Time-Assert TLL (hrs)	:	0.00

Fig. 8. Transformer Thermal Report

IV. THROUGH-FAULT MONITORING

As discussed previously, through-fault current produces both thermal and mechanical effects than can be damaging to the power transformer. The mechanical effects, such as winding compression and insulation wear, are cumulative. The extent of damage from through-faults is a function of the current magnitude, fault duration, and total number of fault occurrences.

Power transformers throughout the power system experience different levels of through-fault current in terms of magnitude, duration, and frequency. The recording capability of some transformer protection relays allows for monitoring and recording of the through-fault current. The relay records the cumulative I^2t value for each phase and compares it against a threshold to provide an alarm. Fig. 9 shows the logic diagram for the cumulative through-fault logic.

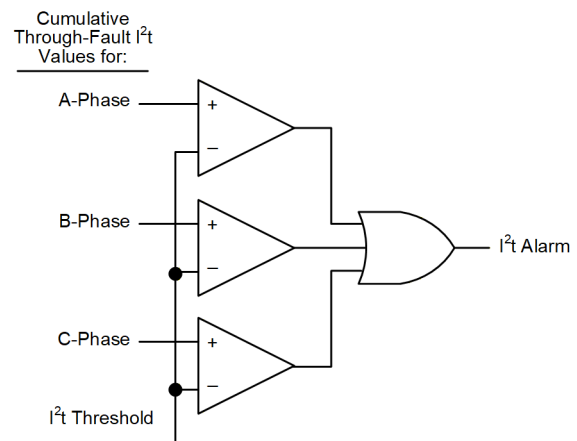

Fig. 9. Cumulative Through-Fault Logic

The recorded values assist the maintenance crew in prioritizing and scheduling transformer maintenance and testing. Over time, the recorded values also provide additional information in determining problems (winding insulation

failure, insulation compression, loose winding, etc.) with the power transformer.

Excessive through-fault occurrences within a given period can also indicate the need for maintenance such as tree trimming and right of way clearance [8].

Fig. 10 shows the through-fault report for a transformer. The report provides the total I^2t value for each phase. The report also provides the date, time, duration, and maximum current through the transformer for each occurrence.

XFMR 1 STATION A		Date: 02/12/04	Time: 18:59:49.130			
Number of Through Faults:	2	Last Reset: 02/10/04 19:56:22				
Winding 1 Total I-squared-t (kA ² seconds, primary):						
A-phase	B-phase	C-phase				
1.783	88.270	6.610				
#	Date	Time	Duration (seconds)	IA (A, primary max)	IB	IC
1	02/14/04	18:59:22.244	5.002	241	4158	260
2	02/11/04	11:37:55.495	30.834	220	241	451

Fig. 10. Transformer Through-Fault Report

V. TRANSFORMER OVEREXCITATION

The flux in the transformer core is directly proportional to the applied voltage and inversely proportional to the frequency. Overexcitation can occur when the per-unit ratio of voltage to frequency (Volts/Hz) exceeds 1.05 p.u. at full load and 1.10 p.u. at no load. An increase in transformer terminal voltage or a decrease in frequency will result in an increase in the flux.

Overexcitation results in excess flux, which causes transformer heating and increases exciting current, noise, and vibration.

Some of the possible causes of overexcitation are:

- Problems with generator excitation system
- Operator error
- Sudden loss-of-load
- Unloaded long transmission lines

A. Transformer Differential Relay and Overexcitation

Saturation of the power transformer core caused by overexcitation results in the flow of excitation current. In an extreme case, the increase in excitation current can cause the transformer differential relay to operate. Because the characteristic of the transformer differential relay does not correlate to the transformer overexcitation limit curve, it is impractical to depend on transformer differential protection to provide overexcitation protection. Furthermore, operation of the transformer differential relay for an overexcitation condition, which is a system phenomenon, can lead fault investigators to start their investigation at the transformer instead of looking for system disturbances. Use a Volts/Hz element to provide overexcitation protection. Under overexcitation conditions, block or restrain the differential element to prevent false operations.

If a Volts/Hz element is not available, use the harmonic content of the excitation current to determine the degree of overexcitation of the transformer core. Table III shows typical harmonic content of the excitation current.

TABLE III.
TRANSFORMER EXCITATION CURRENT AND HARMONICS

Frequency	Magnitude (primary amps)	% of Nominal
Fundamental	22.5	52.0
Third	11.1	26.0
Fifth	4.9	11.0
Seventh	1.8	4.0

The excitation current consists mainly of odd harmonics, with the third harmonic being the predominant harmonic. The third harmonic is a triplen harmonic [9]. Delta-connected transformer windings (power or current transformers) filter out triplen harmonics (3, 9, 15, etc.). Since the next highest harmonic is the fifth harmonic, most transformer differential relays use the fifth harmonic to detect overexcitation conditions.

In applications where the power transformer might be overexcited, block the differential element from operating on transformer exciting current.

B. Overexcitation Protection

Obtain the overexcitation limit for a particular transformer through the transformer manufacturer. The overexcitation limit is either a curve or a set point with a time delay. Fig. 11 shows typical overexcitation limit curves for different transformers.

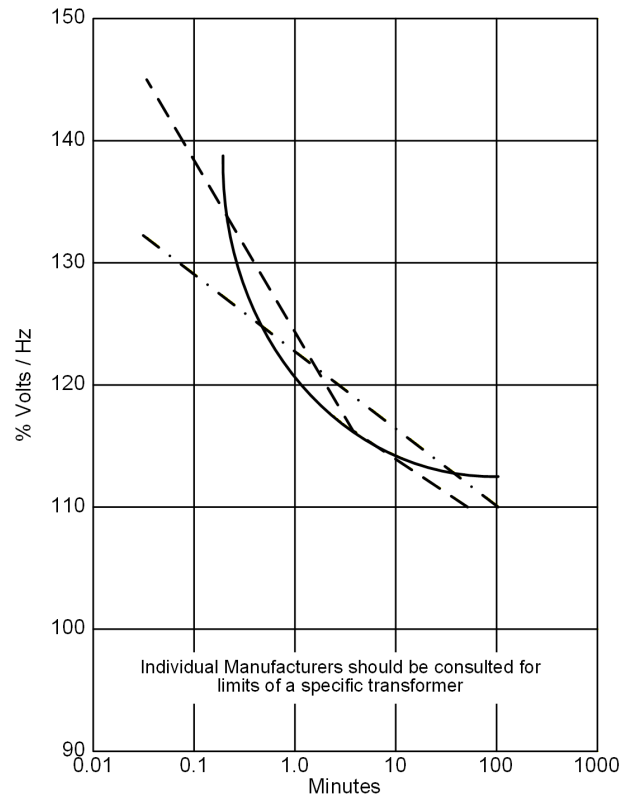

Fig. 11. Typical Transformer Overexcitation Limit Curves

Provide overexcitation protection for power transformers through a Volts/Hz element that calculates the ratio of the measured voltage to frequency in p.u. of the nominal quantities.

In applications that provide overexcitation protection for a generator step-up (GSU) transformer, consider the overexcitation limits of both the GSU and the generator. Then set the overexcitation element to coordinate with the limit curves of both the GSU and the generator. Fig. 12 shows the coordination of the overexcitation element with the generator and the GSU limit curves. Use a composite limit curve to achieve proper coordination.

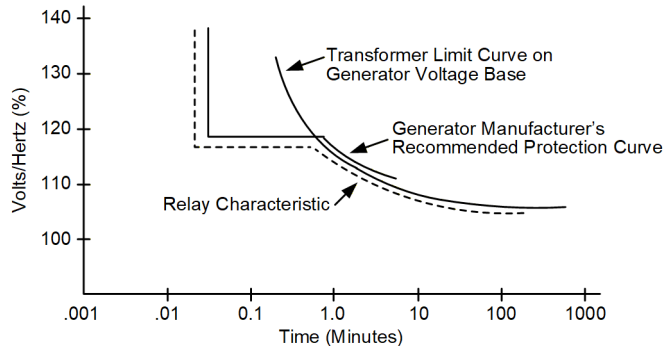

Fig. 12. Overexcitation Protection Coordination Curve

VI. CONCLUSION

Power transformers play a significant role in power system delivery. Proper application of relay elements that monitor a transformer's thermal state and through-faults can provide both short and long term benefits. These benefits include:

- Transformer overload protection, including cyclic overloads
- Continuous transformer thermal status indication that allows the system operator to make transformer loading decisions based on transformer thermal state
- Cooling system efficiency indication
- Records of cumulative per phase I^2t values as seen by the transformer
- Settable I^2t alarm thresholds that can notify the system operator of excessive through-fault current seen by the transformer
- Cumulative I^2t values as a measure to prioritize transformer maintenance

Overexcitation is a system condition and is not limited to generating stations. Proper application of Volts/Hz elements can prevent damage to transformers resulting from system overvoltage or underfrequency conditions.

VII. REFERENCES

- [1] *IEEE Standard General requirements for Liquid-Immersed Distribution, Power, and Regulating Transformers*, IEEE Standard C57.12.00-2000.
- [2] *IEEE Guide for Liquid-Immersed Transformer Through-Fault Current Duration*, IEEE Std C57.109-1993.
- [3] *IEEE Guide for Protective Relay Applications to Power Transformers*, IEEE Std C37.91-2000.
- [4] Stanley E. Zocholl and Armando Guzman, "Thermal models in Power System Protection" presented at the Western Protective Relay Conference, Spokane, 1999.
- [5] *IEEE Guide for Loading Mineral-Oil-Immersed Transformers*, IEEE Std C57.91-1995.
- [6] Roy Moxley and Armando Guzman, "Transformer Maintenance Interval Management."
- [7] SEL-387-0, -5, -6 Current Differential Relay, Overcurrent Relay, Data Recorder Instruction Manual, Schweitzer Engineering Laboratories, Inc., 2005.
- [8] Jeff Pope, "SEL-387 Through-Fault Monitoring Application and Benefits," SEL Application Guide, AG2005-02.
- [9] Stephen J. Chapman, *Electric Machinery Fundamentals*, Fourth Edition. McGraw Hill, p. 714.

VIII. BIOGRAPHIES

Ali Kazemi is a Field Application Engineer for Schweitzer Engineering Labs in New Berlin, Wisconsin. He received his B.S. in Electrical Engineering from Georgia Institute of Technology and his M.S. in Engineering Management from the University of Massachusetts.

Ali started his engineering career at Wisconsin Power & Light Company, where he designed and commissioned protection and control systems for over thirteen years. He then joined Cooper Power Systems in 1998 as a Senior Application Engineer. Ali joined Schweitzer Engineering Labs in 2000.

Ali has presented technical papers at the Ga-Tech and the Western Protective Relay Conferences. He is a member of IEEE and a registered professional engineer in Wisconsin.

Casper Labuschagne has 20 years of experience with the South African utility Eskom, where he served as senior advisor in the protection design department. He began work at SEL in December 1999 as a product engineer in the Substation Equipment Engineering group, and is presently Lead Engineer in the Research and Development group.

Casper earned his Diploma (1981) and Masters Diploma (1991) in Electrical Engineering from Vaal Triangle Technicon, South Africa. He is registered as a Professional Technologist with ECSA, the Engineering Counsel of South Africa.