

Use of Directional Elements at the Utility-Industrial Interface

David Costello, Martin Moon, and Greg Bow
Schweitzer Engineering Laboratories, Inc.

Revised edition released October 2021

Previously presented at the
5th Annual Clemson University Power Systems Conference, March 2006,
59th Annual Georgia Tech Protective Relaying Conference, April 2005,
and 58th Annual Conference for Protective Relay Engineers, April 2005

Originally presented at the
31st Annual Western Protective Relay Conference, October 2004

Use of Directional Elements at the Utility-Industrial Interface

David Costello, Martin Moon, Greg Bow, Schweitzer Engineering Laboratories, Inc.

1. INTRODUCTION

Reverse power elements and directionally supervised overcurrent elements are often employed at the utility-industrial interface by industrial and utility engineers. Improper selection and setting of such elements can cause relay misoperations and plant outages. Therefore, it is critical to understand the proper application of these protective devices. This paper reviews applicable standards and references, and describes the reasons for installing various protective elements at the utility-industrial interface. The paper also reviews the operating characteristics of reverse power, load encroachment, and directionally supervised phase overcurrent elements. Real-world event reports will be used to demonstrate problematic applications and common settings mistakes. Lastly, the paper will recommend proper application principles and settings.

2. EXAMPLE INSTALLATION

A utility-industrial interconnection is shown in Fig. 1. This one-line diagram depicts the case study used for this paper. The utility has two transmission lines that connect to the high-side ring bus. Two delta-wye-connected power transformers supply the industrial distribution buses. The distribution buses are connected through a normally closed tie breaker, Breaker M. Only the protective devices used for Transformer I are shown. Transformer J is protected similarly. For simplicity, protective devices for the transmission lines, low-side buses, and load feeders are excluded.

It is important to note that while many installations such as these would have impedance-grounded, wye-connected secondary systems, this installation is solidly grounded. The grounding method is not critical to this discussion.

Also, the high-side switching station shown here can represent one common source or two isolated sources to Transformers I and J, depending on the state of Breaker F. The switching station one line is not critical to this discussion.

Of particular interest to the authors was the application of the directionally supervised phase overcurrent relay, labeled 67P. What purpose was it intended to serve? Under what conditions was it expected to operate? What

guided the design engineers in their decision to choose, install, and set the relay? In a real-world case study, did the relay operate as expected? If it did not operate as expected, what were the root cause and the proposed solution?

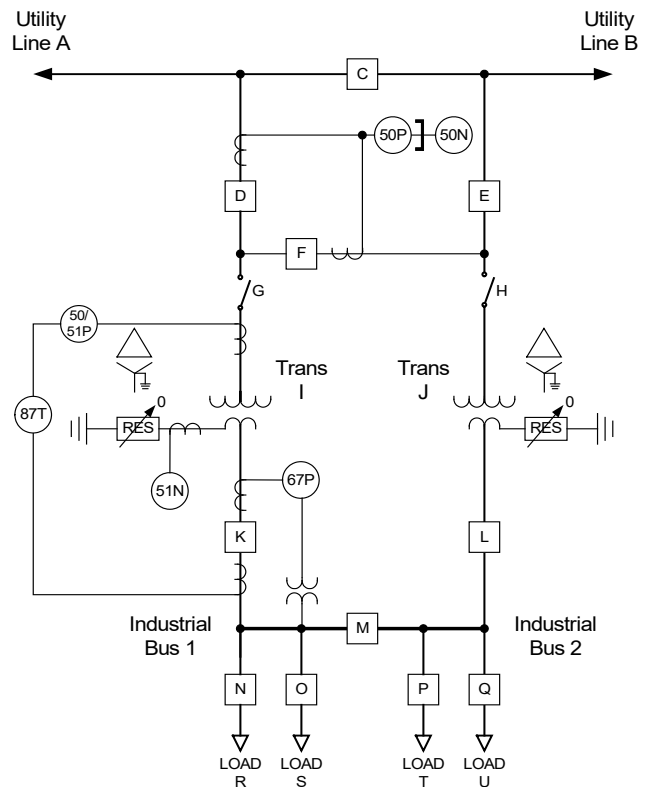

Fig. 1 Simplified Protection One-Line Diagram

3. EXPRESSED PURPOSE OF PROTECTIVE ELEMENTS

Design engineers made the decision to install the 67P relay based on experience and available references.

The 67P relay is intended to detect high-side faults that may occur when the high-side Disconnect Switch G is open, or, when G is closed and Breakers D and F are open. Under these conditions, energizing the fault from the low side of Transformer I must be detected quickly. If the fault is inside the zone-of-protection of the primary transformer protection, Differential Relay 87T, then the 67P relay of-

fers backup protection. If the fault is beyond the high-side CT of the transformer differential, the 67P relay offers the only protection for this fault.

Experience had shown the design engineers that the unexpected can indeed happen, for example, inadvertent closing of the low-side Breaker K during maintenance periods when the high side of Transformer I is open. With safety grounding chains installed on the high side of the transformer, the 67P was immediately called to action to clear the fault. In some installations, the physical distance between the high-side 87T CT and Disconnect G could be quite far, increasing the exposure to faults and the likelihood of the 67P relay being the primary fault-clearing device during these admittedly rare scenarios.

A number of references recommend the application of the 67P device, although for different purposes. In [1], the 67P element is advocated to detect power flow from the low side of Transformer I toward the high side, which it states can be caused by high-side faults under the switching conditions described previously. Reference [1] also states that reverse power flow can occur during times when Breaker F is open, either for high-side faults or load conditions. If local, low-side generation is present, reversed power flow can also occur with Breaker F closed. The 67P will respond to high-side ground faults as long as the high-side ground source remains connected. Further, and important to our investigation, it is commonly stated that because the normal power flow is toward the low-side, the 67P may be set more sensitively and possibly faster than traditional high-side phase overcurrent relays 50/51P (backup transformer high-side protection) or partial differential relays 50P/50N associated with Breakers D and F (bus protection) [1]. References [2] and [3] concur, adding that the 67P relay can be set on minimum tap and time-dial to coordinate with high-side protection. The use of power flow and fault current is used in these references interchangeably, which understandably causes confusion.

In these citations, the emphasis is on detecting high-side faults being fed from a low-side source through the use of the sensitively set directional phase overcurrent elements. Detecting faults and load current flow are discussed in the same context. This explicitly implies the use of traditional directional elements, whose direction decision is based on the product relationship between phase voltage, phase current, and the cosine of the angle between them. These relays calculate the real power between operate quantities. One such element is a traditional negative-sequence directional element, shown in Fig. 2.

Maximum forward operate torque is developed when the negative-sequence current leads the negative-sequence voltage by 180 degrees minus the characteristic angle of the transmission line. A certain minimum power or torque product is required before the element will operate.

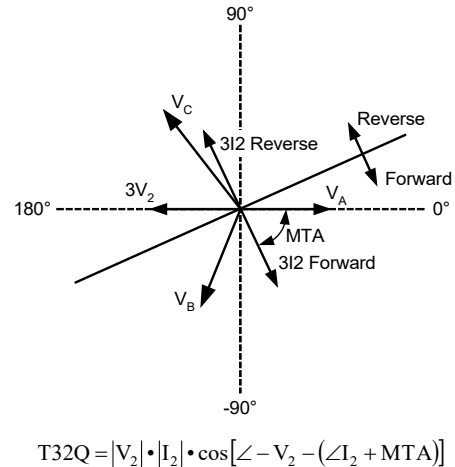

Fig. 2 Traditional Negative-Sequence Directional Element Quantities for Forward A-Phase-to-Ground Fault

These directional elements have been used successfully for many years. However, the negative-sequence voltage developed during a fault is inversely proportional to the strength of the source either behind the relay for forward faults, or in front of the relay for reverse faults. The stronger the source, the less negative-sequence voltage is produced. If we then take into consideration the effect of fault resistance, which tends to lower the amount of fault current available during a fault, we can see the minimum sensitivity for the traditional directional element. Because the torque developed by the directional element in Fig. 2 is directly proportional to the magnitude of voltage and current during a fault, it is susceptible to limits in sensitivity when those quantities are small [4]. As is usually the case when considering security and dependability, a lack of sensitivity (dependability) inherently increases security.

Consider the situation where Breaker F is open, or when Utility Lines A and B are truly independent sources without a high-side ring bus. The possibility exists for the transfer of power between the two sources, whereby current flows from one source down through its associated transformer, through the secondary buses, and back up through the adjacent transformer to the second source. This is generally neither desired nor permitted by utility-industrial interconnection contracts. To prevent this, the author of [5] recommends the installation of directional time-overcurrent relays installed on the secondary side with low or minimum tap, set to coordinate with high-side protection. It is noted that while load current flows through the phase relay, it is normally not in the operating direction [5]. One example of interconnection requirements by a utility for an interconnecting power provider noted that directional power relays may be required to limit power based on contractual agreements [6]. In these references, the directional phase relay is advocated for the detection of undesired power flow, rather than detection of high-side faults.

While our case study did not include a low-side distributed generation source, similarities exist in that the low side can be a source of load or fault current flow to the high side. For an unintentional island condition, in which a distributed resource energizes a portion of the area electric power system through the point of common coupling, the distributed resource interconnection system shall detect the island and cease to energize the area electric power system within two seconds of the formation of the island. A reverse power, or minimum power function, may be used to meet the previous requirement [7]. The author of [8] agrees, stating that relay function 67 is typically used to provide phase fault backfeed detection.

In total, the experiences and references cited above provided a compelling case for why the design engineers felt confident installing the 67P element in Fig. 1. The references also show how one could easily get confused when power flow and fault detection are used interchangeably. When the user of traditional, electromechanical directional phase relays then shops for a new microprocessor-based solution, it is not surprising that a relay is selected for its stated directional overcurrent capabilities, or a 67P element. The challenge, then, is discerning the differences in how directional power, traditional directionally supervised phase overcurrent, and new directional phase overcurrent elements operate for system faults and power flow.

4. REAL-WORLD EVENT EXPLANATION

A remote fault on the high-side utility system, shown in Fig. 1, resulted in an undesired operation of the 67P relay. The fault, which took 19 cycles to clear, was a single line-to-ground fault located several bus sections away from the station. The event summary in Fig. 3 shows that the relay declared a three-phase fault, and tripped by instantaneous/definite-time phase element.

Event Summary		Date:
10/09/03	Time:	16:45:35.606
Event:	ABC T	Location: \$\$\$\$\$\$ Shot: Frequency: 60.01
Target s:	INST 50	
Currents (A Pri),	ABCNQ	570 616 500 6 8 188

The phase currents and voltages in Fig. 3 show little noticeable change between pre-fault and fault signatures, where cycle ten is the demarcation between pre-fault and fault signals. The digital elements that asserted are defined as follows:

- 67P1 "1" = Level 1 Phase Inst or Definite-Time Delayed Element
- 32NG "q" = Reverse Neg-Seq Directional Element, R32QG
- 32PQ "P" = Forward Phase Directional Element, F32P
- 32PQ "q" = Reverse Neg-Seq Directional Element, R32Q

- IN 12 "1" = Optoisolated Input 101 (Monitors Breaker 52A)
- OUT 12 "1" = Output Contact OUT101 (Trip Output)

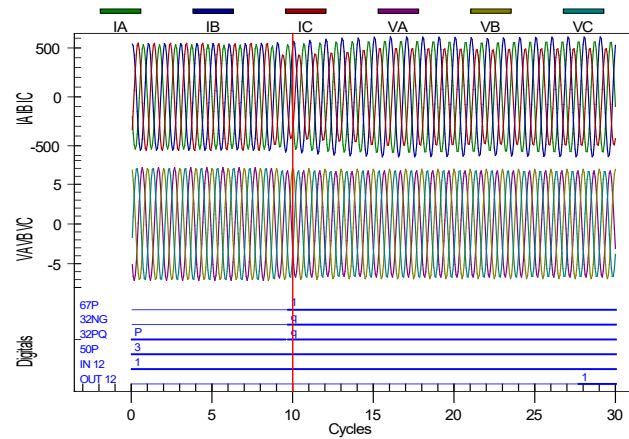

Fig. 3 Oscillography of System Event Which Tripped 67P Relay

From Fig. 3, it can be observed that the relay's negative-sequence voltage-polarized directional element asserted in the reverse direction at the time of the fault. At that instant, the phase overcurrent element 67P1 asserts, as it is directionally supervised by the reverse directional element according to the user settings. The 67P1 element is set for a definite-time delay of 18 cycles before being allowed to trip.

Fig. 4 and Fig. 5 show the phasor magnitudes and angles before the system fault, in primary quantities.

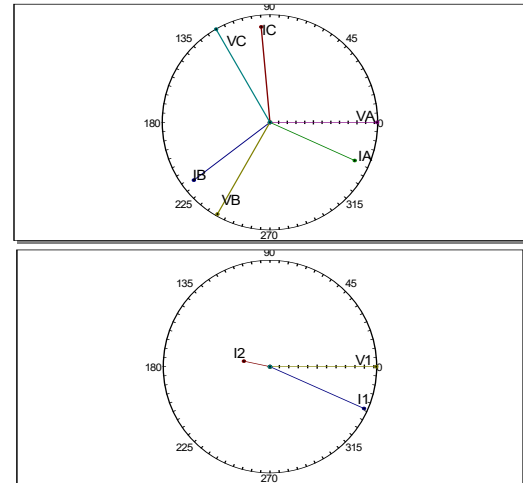

Fig. 4 Prefault (Cycle 5) Phase Voltages and Currents (top), Symmetrical-Components (bottom); V1 Referenced to Zero Degrees

Channel	Mag	Angle	Scale	Show	Ref
IA	533.2	335.5	1	1	0
IB	549.0	217.1	1	1	0
IC	552.7	95.1	1	1	0
IN	2.0	200.8	1	0	0
IG	2.8	245.8	1	0	0
VA	7.1	0.1	1	1	0
VB	7.1	240.1	1	1	0
VC	7.1	119.8	1	1	0
VS	0.0	290.8	1	0	0
Vdc	132.0	N/A	1	0	0
Freq	60.0	N/A	1	0	0
I0	0.7	227.2	1	1	0
I1	544.9	335.9	1	1	0
I2	11.5	168.1	1	1	0
V0	0.0	155.8	1	1	0
V1	7.1	0.0	1	1	1
V2	0.0	259.5	1	1	0

Fig. 5 Prefault Phasors (Cycle 5)

Fig. 6 and Fig. 7 show the phasor magnitudes and angles during the system fault, in primary quantities. Most notable is the increase in negative-sequence current, shown in Fig. 8. The negative-sequence voltage is very low.

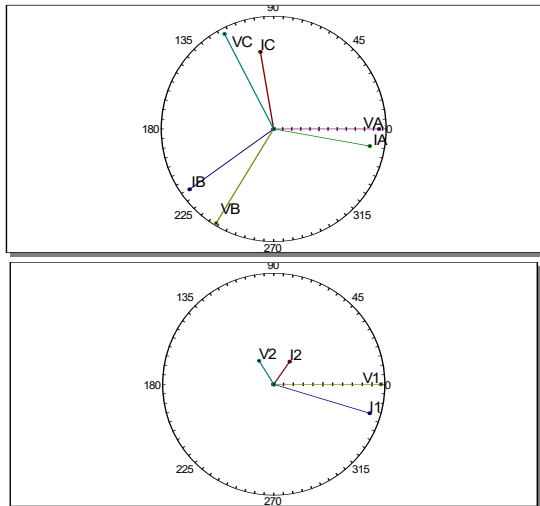

Fig. 6 Fault (Cycle 10) Phase Voltages and Currents (top), Symmetrical-Components (bottom); Referenced to V1 at Zero Degrees

Channel	Mag	Angle	Scale	Show	Ref
IA	537.0	351.2	1	1	0
IB	569.4	217.1	1	1	0
IC	429.8	101.2	1	1	0
IN	7.1	199.8	1	0	0
IG	7.1	199.8	1	0	0
VA	6.7	1.4	1	1	0
VB	7.0	239.9	1	1	0
VC	6.8	118.8	1	1	0
VS	0.0	244.8	1	0	0
Vdc	132.0	N/A	1	0	0
Freq	60.1	N/A	1	0	0
I0	2.6	204.9	1	1	0
I1	509.1	343.2	1	1	0
I2	81.1	55.1	1	1	0
V0	0.0	153.6	1	1	0
V1	6.8	0.0	1	1	1
V2	0.2	121.9	1	1	0

Fig. 7 Fault Phasors (Cycle 10)

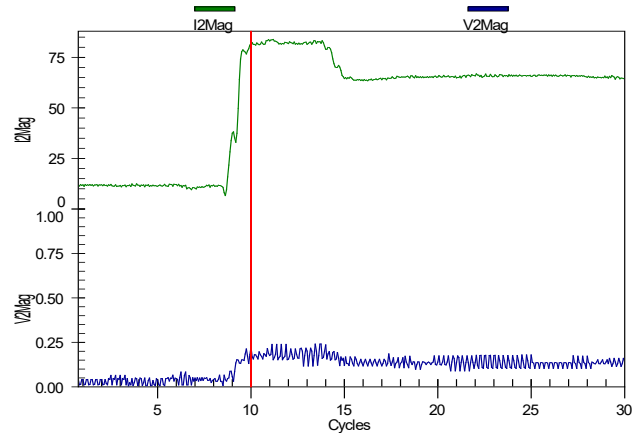

Fig. 8 Fault Phasors (Cycle 10)

Reference [9] states that when the voltage at the terminals of the motors becomes unbalanced, and the motors themselves are not faulted, the current in the motor will be unbalanced. The motor may produce the current unbalance, or the unbalanced current may be the result of the source voltage exceeding an unbalanced limit. For every one percent voltage unbalance at the terminals of the motor, the current unbalance will be approximately equal to the per unit starting current expressed as a percentage (i.e., one percent voltage unbalance will produce approximately six percent current unbalance) [9]. The negative-sequence current, I_2 , observed in Fig. 7 closely matches this approximation.

Sequence network connection diagrams are shown in Fig. 9 and Fig. 10. Regardless of the state of the high-side tie breakers, a path for negative-sequence current flow exists through the load impedance. Note from Fig. 6 that the direction of negative-sequence current flow is consistent with a reverse fault, and, from Fig. 8, that the magnitude of negative-sequence current is significant. In some protection applications, such as sympathetic trip prevention, this reverse negative-sequence flow through the load impedance connection is valuable and put to great use [10]. In this case, however, this path provides enough current to pick up the reverse direction negative-sequence overcurrent fault detectors, enabling the negative-sequence voltage-polarized directional element to assert.

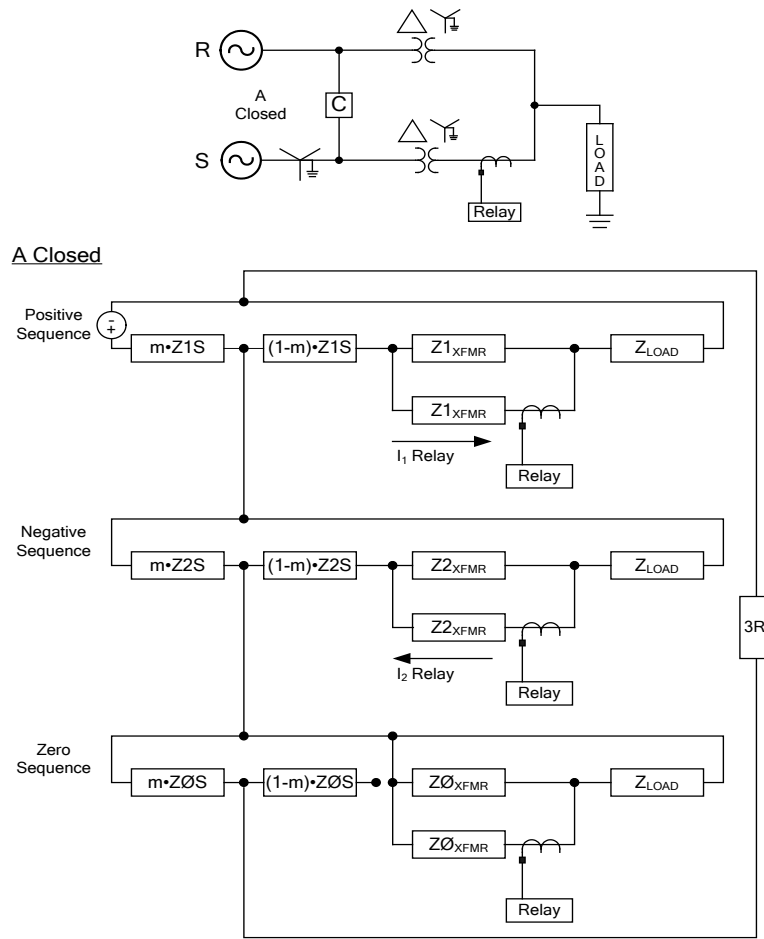

Fig. 9 Sequence Network Connection for a Single Line-to-Ground System With the High-Side Tie Breakers Closed

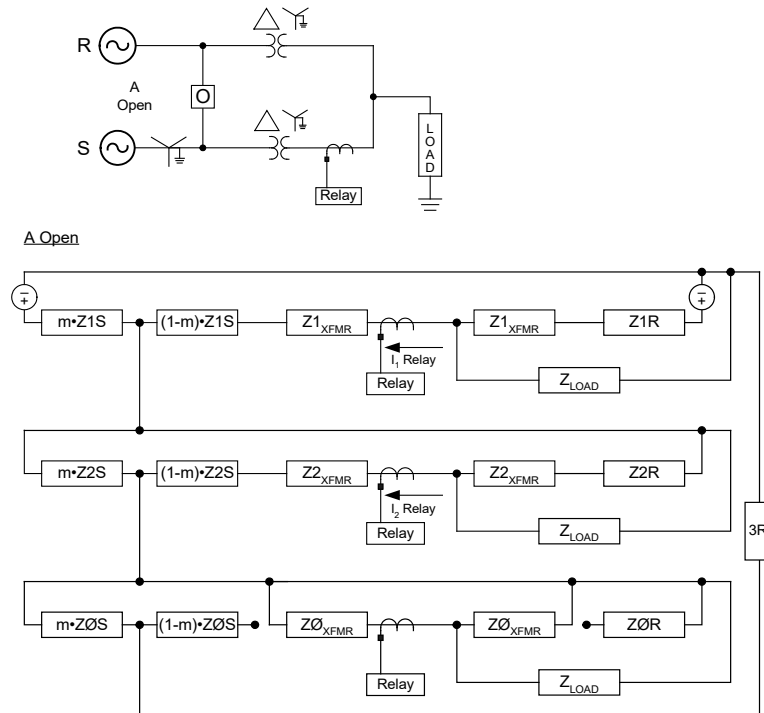

Fig. 10 Sequence Network Connection for a Single Line-to-Ground System With the High-Side Tie Breakers Open

While the engineers applying this relay intended to detect and trip for high-side faults, detecting a line-to-ground fault several buses away was not desired. The sensitivity of the negative-sequence voltage-polarized directional element, the low phase overcurrent element settings (set below forward load), and the lack of familiarity with this particular relay's design and operating characteristics caused this misoperation.

The relevant relay settings are documented below. There are several key points to note. First, the 67P element is allowed to trip through the TR control equation. This

element is set with a pickup of 320 Amps primary or 0.8 Amp secondary, and a definite-time delay of 18 cycles. The element is supervised by a positive-sequence directional element for three-phase faults, and a negative-sequence directional element for phase-to-phase and phase-to-ground faults. The forward direction of the relay, determined by CT polarity and connections, is looking toward the low-side bus. The 67P element is set to look reverse into the transformer and high-side utility source. Forward and reverse directional thresholds are determined automatically from the line impedance data settings.

Instrument Transformers

CTR = 400	CTRN = 240		
PTR = 100.00	PTRS = 1.00	VNM = 72.00	

Line Impedance

ZLMG = 1.00	ZLANG = 45.00	ZOMG = 1.00	ZOANG = 45.00
-------------	---------------	-------------	---------------

Overcurrent Settings

E50P = 1	E50N = 1	E50G = 1
50P1P = 0.80	50N1P = 1.000	50G1P = 0.600
67P1D = 18.00	67N1D = 6.00	67G1D = 6.00

Directional Element Supervision

E32 = AUTO	ELOAD = N	ELCP = YI	
DIR1 = R	DIR2 = N	DIR3 = N	DIR4 = N
ORDER = QV	50P32P = 0.60	ZZF = 0.50	ZZR = 0.70
50QFP = 0.50	50QRP = 0.25	a2 = 0.10	k2 = 0.20
50GFP = 0.50	50GRP = 0.25	a0 = 0.10	
Z0F = 0.50	Z0R = 0.70		

Programmable Control Equations

TR = 67P1T + 67N1T + 67G1T
52A = !N101
67P1TC=1
67N1TC=1
67G1TC=1
67Q1TC=1
CUT101=TRIP
ER = /67P1 + /67N1 + /67G1 + !N101

Global Settings

PTCONN = WE	VSCONN = VS
NFREQ = 60	PHROT = ABC
LER = 30	PRE = 10

The relay event data is shown next.

Relay Identifier	Date: 10/09/03
Time: 16:45:35.606	
Terminal Identifier	
FID-SEL-351A-R107-V0-Z005005-D20030212	
	Out In
	1357 135
Currents (Amps Pri)	Voltages (kV Pri)
IA IB IC IN IG VA VB VC VS Vdc Freq	246A 246
[1]	
-202 541 -335 2 4 -5.1 6.8 -1.7 0.0 132 60.01 1..	
-373 523 -147 2 3 -6.6 5.5 1.0 -0.0 132 60.01 1..	
.	
.	
57 364 -417 2 4 -0.4 6.2 -5.8 0.0 132 60.11 1..	
-152 504 -346 5 5 -3.0 7.0 -4.0 0.0 132 60.11>.... 1..	
continued on next page	

Some of the more important markers used above are explained as follows:

- Arrow “>” = Identifies the Event Report Trigger Row
- Asterisk “*” = Identifies the Row with the Maximum Phase Current

A Mathcad simulation of the directional element calculation confirms that the relay directional decision was correct according to design and settings. The results are shown in Appendix A. Data for the calculations are taken from Cycle 10 in the event report. The measured negative-sequence impedance is compared against a threshold ($Z_{2R} = 0.70$ ohms sec). Because the measured impedance is thirteen times greater and more positive than the threshold, the negative-sequence directional element declares a reverse fault. This is, of course, a correct fault location determination, but demonstrates a sensitivity level not expected or desired in this case.

In researching the undesired operation previously shown, a previous event record was discovered in the relay history that showed similar 67P assertion. In this case, shown in Fig. 11, the assertion of the directional overcurrent element was momentary and did not result in a trip. This simply shows that the event that caused the trip, while unique in its prolonged clearing time, was not an isolated event that can be ignored. We must now understand the relay element operation, develop some recommended solutions, and test those solutions to prove they are valid.

Event Summary	Date: 09/28/03	Time: 20:46:55.900				
Event: ABC	Location: \$\$\$\$\$\$	Shot: Frequency: 59.96				
Target s:						
Currents (A Pri), ABCNQ	548	576	622	1	4	100

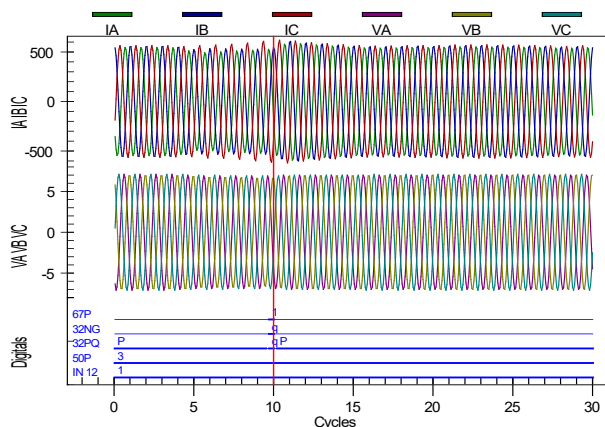

Fig. 11 Oscillography of System Event Which Did Not Trip the 67P Relay

5. OPERATION OF DIRECTIONAL OVERCURRENT ELEMENTS

The directional supervision of the phase overcurrent element is made up of two components. One is the use of positive-sequence voltage polarized phase elements to

detect three-phase faults. The second is a negative-sequence voltage-polarized directional element used to detect unbalanced faults. The element calculates the negative-sequence impedance at the relay location and determines the fault direction from the magnitude and sign of the calculated negative-sequence impedance. In Fig. 12, the relay at Source S must trip for the line-to-ground fault in front of the relay at F1 and restrain for a fault behind the relay at F2. The sequence networks connected for a line-to-ground fault are shown in Fig. 13.

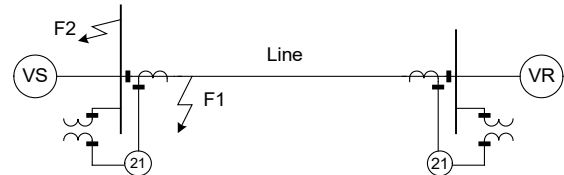

Fig. 12 Equivalent One-Line for a Simple Transmission Line

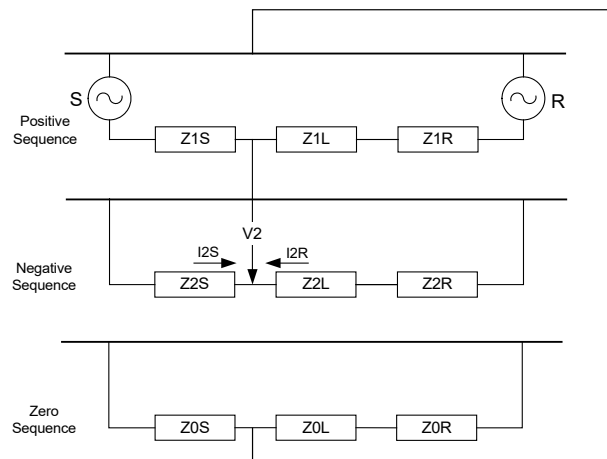

Fig. 13 Sequence Network Connection for a Single Line-to-Ground Fault, $3R_f = 0$

Since there are no sources in the negative-sequence network, the negative-sequence voltage V_2 is the voltage drop across the S-bus source impedance Z_{2S} caused by the current I_{2S} . V_{2S} is also the voltage drop across the impedance $(Z_{2L} + Z_{2R})$ caused by the current I_{2R} . If the fault is in front of the relay, its voltage is $-V_{2S}$ and its current is $+I_{2S}$. Consequently, the negative-sequence element measures the impedance $-Z_{2S}$. However, if the fault is behind the relay, the current changes abruptly to $-I_{2R}$, and the directional element measures the impedance $(Z_{2L} + Z_{2R})$. The measured impedance can be plotted on an R-X impedance plane. Impedance thresholds, shown in Fig. 14, are compared to the measured impedance. The relay forward directional element asserts for an impedance measurement less than the setting threshold Z_{2F} . The relay reverse directional element asserts for a measurement greater than the setting threshold Z_{2R} .

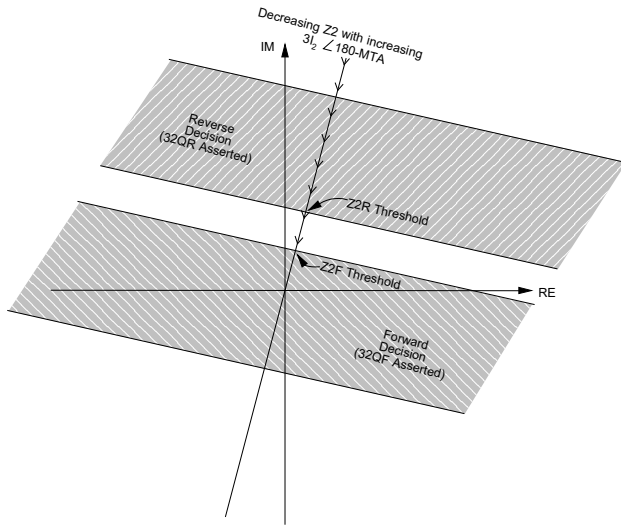

Fig. 14 Forward and Reverse Negative-Sequence Impedance Thresholds

In most applications, settings of $Z2F = \frac{1}{2} Z1MAG$, and $Z2R = Z2F + 0.2$, are sufficient. It can be seen from Fig. 13 that this rule of thumb assumes an infinite bus at S and R; additional source impedance only pushes the measured negative-sequence impedance further from the thresholds. In this application, it can be argued that accurate line and load impedance data in front of the relay may not be readily available. In these cases, one can generally use the rule of thumb starting point settings of $Z2F = -0.1$ secondary ohms and $Z2R = 0.1$ secondary ohms for the forward and reverse negative-sequence impedance directional element thresholds, respectively, subject to validation and testing for the specific application [11]. Remember, in our case, the measured impedance was roughly 13 times greater than the $Z2R$ threshold. It is evident that increasing the $Z2R$ threshold will not solve the root cause of the problem.

It can be seen from Fig. 14 that a fault with little or no voltage would still produce a direction decision. Likewise, a fault with little to no current can produce a direction decision, as long as minimum fault detector values are exceeded. The negative-sequence current ($3I2$), in the reverse direction for example, must exceed an overcurrent value equal to setting 50QRP. The ratio of negative-sequence current to positive-sequence current must also exceed a value equal to the setting $a2$. Relay default settings are $50QRP = 0.25$ ($3I2$) Amps secondary and $a2 = 0.10$.

In this event, the relay's phase overcurrent pickup, which responds to the maximum phase (I_A or I_B or I_C), was set to 0.8 Amps secondary. The prefault load current on all phases was 1.3 Amps secondary. So, the phase overcurrent element was always armed, waiting only on permission from the supervising directional elements. When the distant line-to-ground fault occurred, this produced about 6 volts secondary of negative-sequence voltage ($3V2$), and 0.6 Amps secondary of negative-sequence current ($3I2$).

The ratio of negative- to positive-sequence current was 16 percent. As shown in the Mathcad calculation in Appendix A, all necessary requirements were fulfilled for the negative-sequence directional element to assert in the reverse direction. This enabled the phase overcurrent element to start timing to trip 18 cycles later.

This relay's negative-sequence directional element was designed for sensitivity. It is apparent that the sensitivity of this element varies from traditional, power-based electromechanical directional elements. This case is a good reminder that sensitivity must be considered when applying and coordinating settings, especially when using a new relay for the first time.

There are several options for solutions. The first option is to desensitize the negative-sequence directional element by increasing the 50QRP and $a2$ fault detectors. There are two main disadvantages to this solution. First, by increasing the fault detectors, we are decreasing the sensitivity of the fault coverage [12]. That may not be seen as a large downside in this case, as too much sensitivity seems to have caused us trouble. However, the main purpose of this element is to supervise and allow the 67P to detect high-side phase-to-phase faults. The sequence diagrams of Fig. 9 and Fig. 10 show the load and transformer impedances limiting available fault current. The second drawback is how do we reliably determine the set points for 50QRP and $a2$? In this case, we have field data from two faults that can be used to provide information. Otherwise, one would have to model the system, including the load impedances, and perform a fault study. Considering that accurate line impedance data was not known or input into the relay settings when the relay was first applied, we should not assume that a detailed fault study could be performed.

Another solution is to leave the directional element thresholds and fault detectors so they maintain sensitivity, but use the negative-sequence directional element only to supervise negative-sequence overcurrent elements, those that operate on calculated negative-sequence current ($3I2$). Reference [13] states that since negative-sequence relays do not respond to balanced load or three-phase faults, negative-sequence overcurrent elements are particularly applicable to delta-wye grounded transformers. The guide pronounces the benefits of using the negative-sequence relay applied to the transformer high side to detect transformer and secondary ground faults [13].

The same reasoning can be applied for relays on the low side of the transformer installed to detect high-side faults. In distributed generation cases, with the utility source breaker open, the generator only contributes current to three-phase and phase-to-phase line faults. With the utility source ground connection isolated by the open breaker, the delta-connected winding opens the zero-sequence current path, blocking current flow for single phase-to-ground line faults.

Once the utility source breaker opens, there is no way to detect that a high-side ground fault still exists using current or voltage measurement techniques on the low side of the transformer [14]. The same holds true in the one-line diagram of Fig. 1. Reverse directional negative-sequence overcurrent relays may be used to detect phase-to-phase and phase-to-ground faults on the high side of the delta-wye transformer, relegating the reverse directional phase overcurrent relays to sensing the higher magnitude three-phase faults.

In setting the pickup of the negative-sequence overcurrent element, we must ensure that the minimum sensitivity is set greater than normal expected load unbalance. In our case, we assume that we will be safely above normal system unbalance by starting with a pickup setting equal to that of the original phase overcurrent. In this case, we would start with a setting of 0.8 Amps, which was our original phase overcurrent setting.

Next, we must also coordinate the element with down line phase overcurrent relays. Reference [15] shows that negative-sequence current (3I2) seen on the delta-side of a transformer for a phase-to-phase fault on the wye-side is 1.5 times greater than the maximum phase current. It can be shown that the same holds true for negative-sequence

current seen on the wye-side of a transformer for a phase-to-phase fault on the delta-side. A good rule of thumb, therefore, is to start with the normal phase current value that you would have used for a phase overcurrent pickup setting, and perform normal coordination with down line phase devices, deriving time dial and curve settings as if you were installing a phase relay. Then, simply multiply the equivalent phase overcurrent pickup setting by $\sqrt{3}$, or 1.73 [16].

In our case, our new negative-sequence element pickup becomes 1.4 Amps secondary (3I2). A review of Fig. 5 and Fig. 7 proves that the observed negative-sequence current never exceeded 0.6 Amps secondary (3I2). Therefore, by setting the negative-sequence element to 1.4 Amps secondary (3I2), and supervising with the negative-sequence directional element, we maintain the same sensitivity as the original phase overcurrent relay setting, while ensuring that the element is more secure and will not operate for balanced load or remote unbalance faults. The phase overcurrent element settings can also remain sensitive, as long as we supervise with the positive-sequence directional element only (shown in Fig. 16), ensuring that this element does not operate for forward load or fault current.

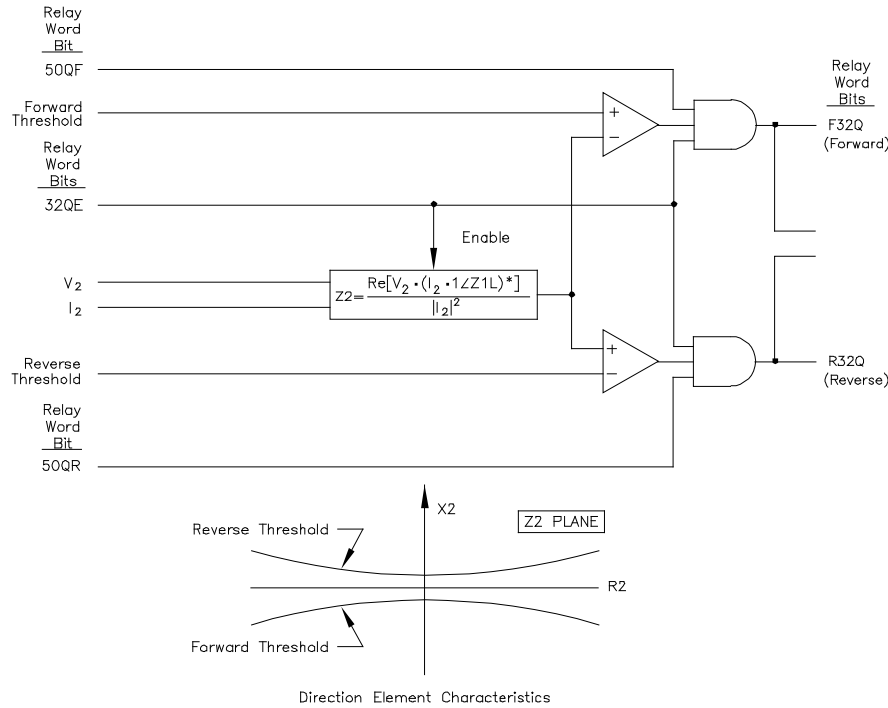

Forward Threshold:

$$\text{If } Z2F \text{ Setting} \leq 0, \text{ Forward Threshold} = 0.75 \cdot Z2F - 0.25 \cdot \left| \frac{V_2}{I_2} \right|$$

$$\text{If } Z2F \text{ Setting} > 0, \text{ Forward Threshold} = 1.25 \cdot Z2F - 0.25 \cdot \left| \frac{V_2}{I_2} \right|$$

Reverse Threshold:

$$\text{If } Z2R \text{ Setting} \geq 0, \text{ Reverse Threshold} = 0.75 \cdot Z2R + 0.25 \cdot \left| \frac{V_2}{I_2} \right|$$

$$\text{If } Z2R \text{ Setting} < 0, \text{ Reverse Threshold} = 1.25 \cdot Z2R + 0.25 \cdot \left| \frac{V_2}{I_2} \right|$$

Fig. 15 Logic Diagram for Negative-Sequence Voltage-Polarized Directional Element

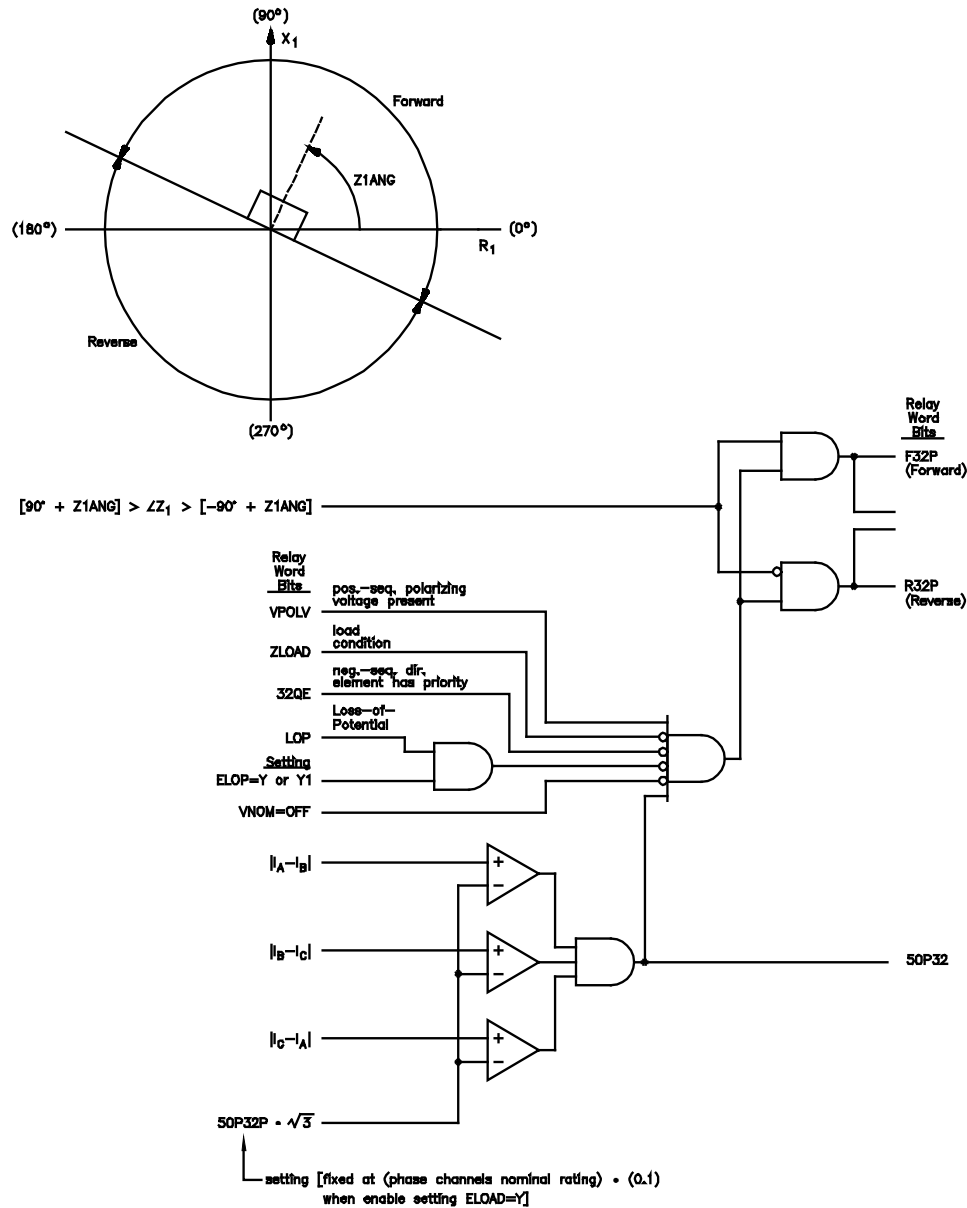

Fig. 16 Logic Diagram for Positive-Sequence Voltage-Polarized Directional Element

6. OPERATION OF LOAD-ENCROACHMENT ELEMENTS

Load-encroachment logic allows phase overcurrent elements to be set independent of load. The relay calculates positive-sequence impedance, which is representative of a largely balanced three-phase load. While not a true power element, positive-sequence impedance gives a good load approximation. Notice in Fig. 17 that the load-encroachment logic operates only when positive-sequence current (I_1) is greater than ten percent of nominal current. For balanced load, I_1 should equal the phase current magnitude.

To further ensure that our phase overcurrent element only operates for reverse three-phase faults, we should enable load-encroachment logic, particularly in the for-

ward (load flowing out, or ZLOUT) region. The settings for PLAF and NLAf, forward positive and negative load angles, respectively, are calculated as the arc cosine of the positive and negative expected power factor (lead and lag). The setting ZLF is based on maximum expected load, plus a margin.

7. OPERATION OF REVERSE POWER ELEMENTS

For detecting directional power conditions, it is highly recommended that one use elements included in microprocessor-based relays that were designed for that specific purpose. Fig. 18 shows the power element operation of a commonly used microprocessor relay. The elements require a minimum current of one percent times nominal for secondary voltages greater than 40 volts, and ten percent

of nominal for voltages between 10 and 40 volts secondary. During a system disturbance, because of high sensitivity of the power elements and changing phase angles or frequency, a minimum operate time of 5 cycles is generally recommended. Power elements may operate during faults as well, so programmable logic may be used to disable the power element operation when a fault-detecting element is asserted, giving fault detection priority to those elements designed and enabled for that function.

Load encroachment may be used as a power element of sorts, with the noted limitations of being indicative of balanced three-phase load only and having a minimum sensitivity of ten percent of nominal current. If these limitations are acceptable, and the existing relay in place does not include true power elements, load encroachment can indicate real power in or out, using the ZLIN and ZLOUT regions. In this function, typically the positive and negative load angles are set to +90 degrees and -90 degrees, respectively.

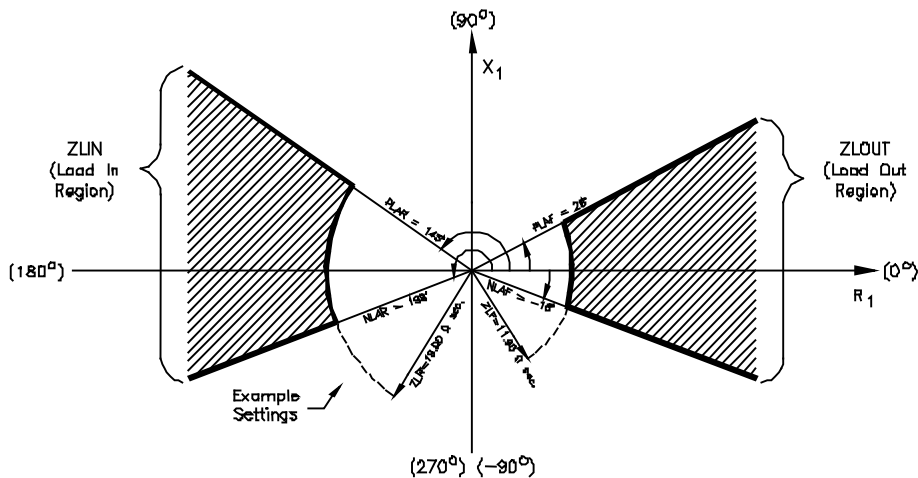
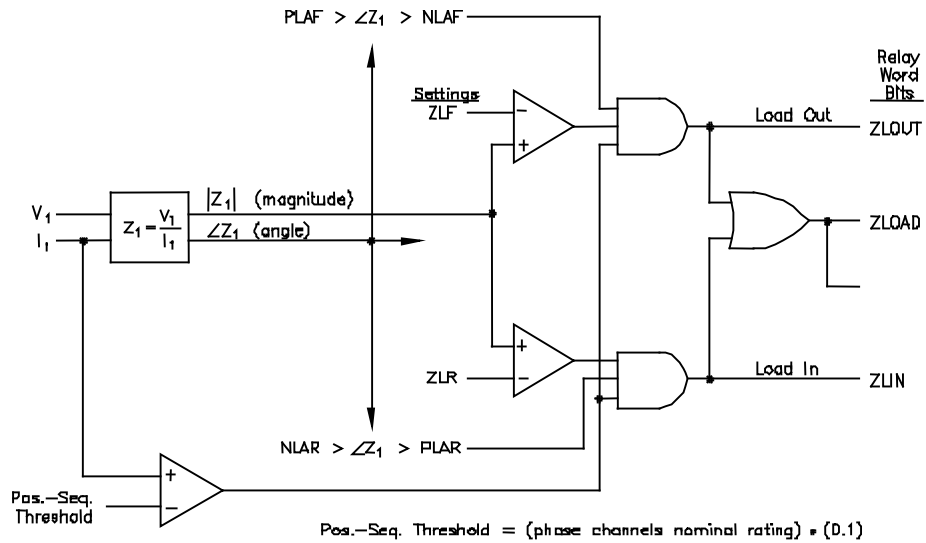

Fig. 17 Load-Encroachment Logic Diagram

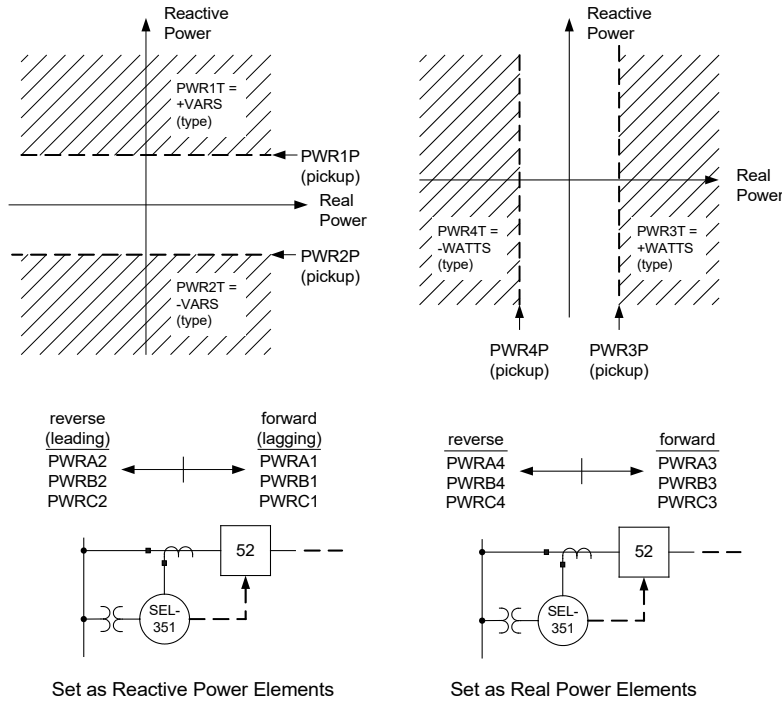

Fig. 18 True Directional Power Elements Operation in the Real/Reactive Power Plane

8. SUMMARY OF RECOMMENDED SETTINGS

Settings that were changed from the original installation are noted below, with comments inserted as necessary.

Line Impedance

Z1MAG = 1.00 Z1ANG = 45.00 Z0MAG = 1.00 Z0ANG = 45.00

No changes were made to line impedance settings. However, it is assumed that these are inaccurate; therefore, fault location is disabled and directional settings are manually input rather than letting the relay automatically calculate directional thresholds from these settings.

Line Impedance

EPWR = 3P1
 3PWR1P = 10.00 PWR1T = WATTS PWR1D = 5.00

Power elements were enabled simply as an example. No control was performed with them.

Overcurrent Settings

E50P = 1	E50N = 1	E50G = 1	E50Q = 1
50P1P = 0.80	50N1P = 1.000	50G1P = 0.600	50Q1P = 1.400
67P1D = 18.00	67N1D = 6.00	67G1D = 6.00	67Q1D = 18.00

The phase overcurrent pickup and definite time delay were left unchanged. One negative-sequence overcurrent element was enabled, with pickup set to $\sqrt{3}$ times the phase overcurrent.

Directional Element Supervision

E32 = Y	ELOAD = Y	ELOP = Y1
ZLF = 13.00	ZLR = 128.00	
PLAF = 30.00	NLAF = -30.00	PLAR = 180.00 NLAR = 180.00
DIR1 = R	DIR2 = N	DIR3 = N DIR4 = N
ORDER = Q	50P32P = 0.60	Z2F = -0.10 Z2R = 0.10
50QFP = 0.50	50QRP = 0.25	a2 = 0.10 k2 = 0.20

Directional control is enabled, but automatic settings are turned off (E32 = Y). Load encroachment is enabled and maximum forward load is calculated using 5 Amps and 72 volts per phase, with an additional ten percent margin. Load angles are based on 30-degree power factor angles. Load-encroachment supervision, once enabled, is automatically included in positive-sequence directional supervision.

The forward and reverse negative-sequence impedance directional thresholds are set to -0.10 and +0.10 ohms secondary, respectively. Negative-sequence directional control is automatically used by the relay to supervise the negative-sequence and phase overcurrent relays. Further programmable logic is required to ensure that the phase overcurrent elements ignore the negative-sequence directional element. All other fault detectors are left at their sensitive, factory default values.

Programmable Control Equations

TR = 67P1T + 67N1T + 67G1T + 67Q1T
52A = IN101
67P1TC = R32P
67N1TC = 1
67G1TC = 1
67Q1TC = 1
OUT101 = TRIP
ER = /67P1 + /67N1 + /67G1 + /67Q1

The negative-sequence overcurrent element is added to the trip functions. The phase overcurrent element is torque-controlled by the reverse positive-sequence directional element, R32P. The phase element is only allowed to operate when the positive-sequence directional element asserts in the reverse direction, and the measured positive-

sequence impedance does not lie in the forward load region.

These settings retain the original engineer's sensitivity (pickup values were not increased), speed (trip delays were not increased), while adding security to ensure this misoperation will not reoccur.

9. TESTING PROPOSED SOLUTIONS

As W. Edward Deming said, "In God we trust, all others bring data." The last remaining item in event and root cause analysis is testing the solution. Therefore, the original event reports from the field were converted to IEEE COMTRADE files. The files, once properly scaled and set up, were played into a relay in the lab through relay test equipment.

Intermediate solutions implemented in the field by the engineer were tested. Results were mixed. Increasing the reverse directional threshold Z2R alone was not successful. Increasing directional element fault detectors alone prevented the misoperation, but at the expense of fault sensitivity and added dependence on fault studies for settings. Increasing overcurrent pickup settings and increasing time-delay prevented the misoperation at the expense of less fault sensitivity and slower fault clearing.

The goal of the settings solution proposed in this paper is to retain fault sensitivity, speed, and improve security with minimal engineering effort (i.e., no fault studies, few settings calculations).

The original event was played via COMTRADE twenty times through the test set to ensure that the solutions presented remained secure for the system faults experienced in the field during the original misoperation. Graphical results are displayed in Fig. 19 and Fig. 20.

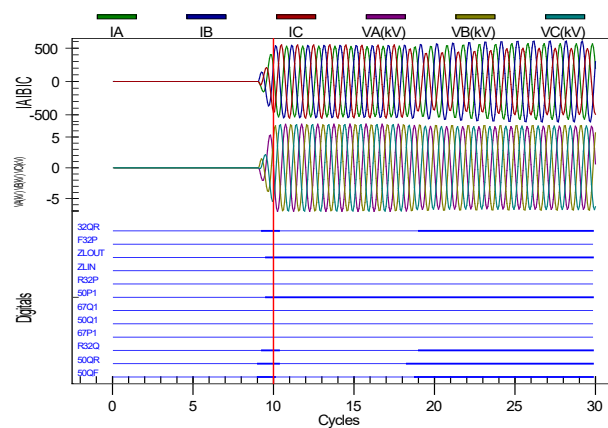
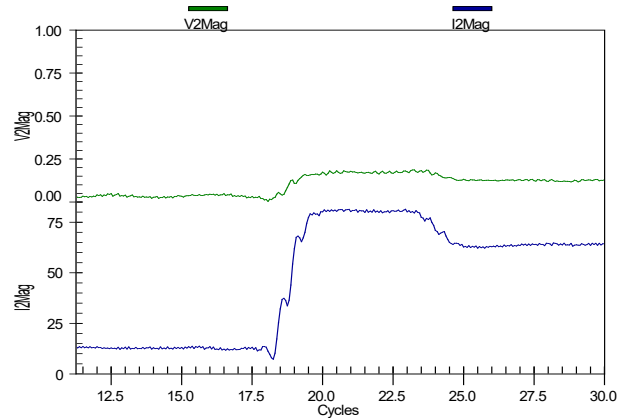

Fig. 19 COMTRADE Event Playback Proves Settings Recommendations Are Secure



Channel	Mag	Angle	Scale	Show	Ref
IA	532.2	352.8	1	1	0
IB	565.3	218.9	1	1	0
IC	429.7	102.9	1	1	0
IN	0.0	84.1	1	0	0
IG	7.5	208.3	1	0	0
VA(kV)	6.8	1.0	1	1	0
VB(kV)	7.0	240.2	1	1	0
VC(kV)	6.8	118.8	1	1	0
VS(kV)	0.1	12.0	1	0	0
VDC	22.0	N/A	1	0	0
FREQ	60.1	N/A	1	0	0
I0	2.6	199.8	1	1	0
I1	506.2	344.9	1	1	0
I2	79.1	57.8	1	1	0
V0	0.0	333.7	1	1	0
V1	6.8	0.0	1	1	1
V2	0.2	126.6	1	1	0

Fig. 20 IEEE COMTRADE Replay Phasors

10. CONCLUSIONS

Based on the data from this case study, we can make some general conclusions.

1. Long-established protection practices are, in many cases, based on traditional electro-mechanical-based protection technology. These practices should be reviewed as new devices with different operating characteristics and should be applied to ensure that the desired outcome is achieved.
2. Microprocessor-based relays offer enhanced directional element sensitivity for greater fault protection.
3. The maximum sensitivity of a particular protection element must be reviewed to ensure secure operation during normal load, expected operating conditions, and system unbalances.
4. In microprocessor-based relays, true directional power elements, rather than directional-supervised phase overcurrent elements, should be used to detect power flow. In this case, reverse power elements should be enabled to detect power flow from the transformer low to high side.
5. Load-encroachment characteristics can be used, with noted sensitivity limitations, as three-phase real directional power elements.

6. Three-phase fault detection is made more secure through the use of load encroachment, which restrains the phase overcurrent operation regardless of current level, when the apparent positive-sequence impedance lies within the load region.
7. Phase overcurrent elements can be supervised with a positive-sequence voltage-polarized directional element that responds only to three-phase faults and includes load-encroachment supervision. In the example installation, the phase overcurrent element should be used for detecting three-phase faults on the transformer high side that are fed from the low-side bus.
8. Phase-to-phase fault detection using negative-sequence overcurrent elements, which naturally restrain during periods of balance load, can retain sensitivity for faults and security during load.
9. Negative-sequence elements can be supervised with a negative-sequence voltage-polarized directional element. In the example installation, the negative-sequence overcurrent element should be used for detecting phase-to-phase faults on the high side that are fed from the low-side bus.
10. Phase overcurrent elements should be used alone only if their pickup can be set above expected load and below minimum fault sensitivity. Adjusting positive-sequence current restraint factor (a_2) and reverse directional negative-sequence fault detector (50QRP) can be increased to desensitize the negative-sequence directional element, but comes at the price of decreased fault coverage and increased setting ambiguity.
11. When accurate line and load impedances are not known, one can generally use the rule of thumb starting point settings of $Z_2F = -0.1$ secondary ohms and $Z_2R = 0.1$ secondary ohms for the forward and reverse negative-sequence impedance directional element thresholds, respectively, subject to validation and testing for the specific application.
12. Analysis of microprocessor-based relay event records is an invaluable problem-solving tool, the importance of which cannot be overemphasized.
13. Proposed problem solutions should be thoroughly modeled and tested prior to implementation on a power system. As W. Edward Deming said, "In God we trust, all others bring data."
14. IEEE COMTRADE files provide an excellent method by which real-world event files can be replayed through test equipment into relays for the purpose of validating proposed problem solutions prior to implementation on a power system.

11. ACKNOWLEDGEMENTS

The authors express their sincere appreciation for the experience and expertise shared by F. E. (Floyd) Weisse,

P.E., Senior Consultant for Dashiell Corporation, during the research phase of writing this technical paper.

12. REFERENCES

- [1] *Transformer Protection Application Guide*, G Rockefeller, Basler Electric, 1999.
- [2] Transformer Protection, Industrial and Commercial Power System Applications Series, PRSC-3A, Westinghouse, 1978.
- [3] *Protective Relays Application Guide*, GEC-Alstom T&D Protection and Control.
- [4] B. Fleming, "Negative-Sequence Impedance Directional Element," presented at the 10th Annual ProTest User Group Meeting, Pasadena, California, 1998.
- [5] J. Lewis Blackburn, *Protective Relaying: Principles and Applications*, New York: Marcel Dekker, 1998.
- [6] Long Island Power Authority Control and Protection Requirements for Independent Power Producers, Transmission Interconnections.
- [7] *IEEE Standard for Interconnecting Distributed Resources with Electric Power Systems*, IEEE Standard 1547™-2003.
- [8] C.J. Mozina, "Interconnection Protection of Dispersed Generators in the New Millennium," presented at the Texas A&M University Conference for Protective Relay Engineers, College Station, Texas, 2000.
- [9] B.H. Moisey, *Concepts of Motor Protection*, Australia: B.H. Moisey, 1997.
- [10] J. Roberts, T. Stulo, and A. Reyes, "Sympathetic Tripping Problem Analysis and Solutions," presented at the 24th Annual Western Protective Relay Conference, Spokane, Washington, 1997.
- [11] K. Zimmerman, "Negative-Sequence Impedance Directional Element; What Happens When Standard Settings Don't Work?" presented at the Annual Technical Conference of the InterNational Electrical Testing Association (NETA), San Antonio, Texas, 2004.
- [12] J. Roberts, E.O. Schweitzer, III, R. Arora, and E. Poggi, "Limits to the Sensitivity of Ground Directional and Distance Protection," presented at the 22nd Annual Western Protective Relay Conference, Spokane, Washington, 1995.
- [13] *IEEE Guide for Protective Relay Applications to Power Transformers*, IEEE Standard C39.91-1995.
- [14] K. Behrendt, "Protection for Unexpected Delta Sources," presented at the 29th Annual Western Protective Relay Conference, Spokane, Washington, 2002.
- [15] A. Elnewihi, E. Schweitzer, and M. Feltis, "Negative-Sequence Overcurrent Element Application and Coordination in Distribution Protection," *IEEE Transactions on Power Delivery*, Vol. 8, No. 3, July 1993.
- [16] SEL-351S Relay, Meter, Control, Fault Locator Instruction Manual, 20030908.

13. BIOGRAPHIES

Greg Bow earned a BSEE from the University of Idaho in 1987. He started his career as a product development engineer at Boeing Commercial Aircraft Company, where he worked for three years. He then worked as a design engineer for three years at John Fluke Manufacturing. In 1993, Greg joined Schweitzer Engineering Laboratories, where he has served as a test engineer, software engineer, Manager of Switch and Recloser Group, and lead product engineer. He presently serves as a field application engineer for SEL in Boerne, Texas. Greg is a member of the IEEE.

David Costello graduated from Texas A&M University in 1991 with a BSEE. He worked as a system protection engineer for Central and Southwest, and served on the System Protection Task Force for the ERCOT. In 1996, David joined Schweitzer Engineering Laboratories,

where he has served as a field application engineer and regional service manager. He presently holds the title of senior application engineer and works in Boerne, Texas. He is a member of IEEE, and the planning committee for the Conference for Protective Relay Engineers at Texas A&M University.

Martin Moon received a BA in Physics from Grinnell College in 1989, and a BSEE from the University of Nevada, Reno, in 1991. He worked as a substation design engineer and a protection and control engineer at Sierra Pacific Power Company. In 1996, Martin joined General Electric as an application engineer for medium voltage switchgear products. In 1998, he joined Schweitzer Engineering Laboratories as a protection engineer in the Systems and Services Division. He presently serves as a field application engineer for SEL in Boerne, Texas. Martin is a registered Professional Engineer in the state of California, and a member of the IEEE.

14. PREVIOUS PUBLICATIONS

Presented at WPRC 2004 and Texas A&M 2005.

15. APPENDIX A

Negative Sequence Impedance Directional Element

Enter Settings

$$\begin{aligned} \text{CTR} &:= 400 & \text{Z2F} &:= 0.5 & \text{_50QFP} &:= 0.5 & \text{a2} &:= .1 \\ \text{PTR} &:= 100 & \text{Z2R} &:= 0.7 & \text{_50QRP} &:= 0.25 \\ \text{Z1MAG} &:= 1 & \text{Z1ANG} &:= 45\text{-deg} \end{aligned}$$

Enter Data From Event Report

$$\begin{aligned} \text{I1mag} &:= 509.1 & \text{I1ang} &:= 343.2\text{-deg} & j &:= \sqrt{-1} \\ \text{I2mag} &:= 81.1 & \text{I2ang} &:= 55.1\text{-deg} \\ \text{V2mag} &:= .2 & \text{V2ang} &:= 121.9\text{deg} \end{aligned}$$

Calculate Symmetrical Components

$$\begin{aligned} \text{I1} &:= \frac{\text{I1mag}}{\text{CTR}} (\cos(\text{I1ang}) + \sin(\text{I1ang}) j) & \text{I1} &= 1.218 - 0.368i \\ \text{I2} &:= \frac{\text{I2mag}}{\text{CTR}} (\cos(\text{I2ang}) + \sin(\text{I2ang}) j) & \text{I2} &= 0.116 + 0.166i \\ \text{V2} &:= \frac{\text{V2mag}}{\text{PTR}} \cdot 1000 (\cos(\text{V2ang}) + \sin(\text{V2ang}) j) & \text{V2} &= -1.057 + 1.698i \\ \text{ZL} &:= (\cos(\text{Z1ANG}) + \sin(\text{Z1ANG}) j) & \text{ZL} &= 0.707 + 0.707i \\ \text{_3I2} &:= \text{I2} \cdot 3 \end{aligned}$$

Determine if Supervising / Enabling Fault Detectors Assert

$$\begin{aligned} \text{_50QF} &:= \text{if}(|\text{_3I2}| > \text{_50QFP}, 1, 0) & \text{_50QF} &= 1 \\ \text{_50QR} &:= \text{if}(|\text{_3I2}| > \text{_50QRP}, 1, 0) & \text{_50QR} &= 1 \\ \text{_32QE} &:= \text{if}(|\text{I2}| > \text{a2} \cdot |\text{I1}|) \wedge (\text{_50QF} \vee \text{_50QR}), 1, 0] & \text{_32QE} &= 1 \end{aligned}$$

These equations are valid for Z2R>=0 and Z2F>0

If Z2F > 0 then

$$\text{FT} := 1.25 \cdot \text{Z2F} - 0.25 \cdot \frac{\text{V2}}{\text{I2}} \quad \text{FT} = -1.841$$

If Z2R >= 0 then

$$\text{RT} := 0.75 \cdot \text{Z2R} + 0.25 \cdot \frac{\text{V2}}{\text{I2}} \quad \text{RT} = 2.991$$

$$\text{Z2} := \frac{\text{Re}(\text{V2} \cdot \overline{[\text{I2} \cdot (\text{ZL})]})}{(|\text{I2}|)^2} \quad \text{Z2} = 9.159$$

$$\text{F32Q} := \text{if}(\text{FT} > \text{Z2}) \wedge \text{_32QE}, 1, 0] \quad \text{F32Q} = 0$$

$$\text{R32Q} := \text{if}(\text{Z2} > \text{RT}) \wedge \text{_32QE}, 1, 0] \quad \text{R32Q} = 1$$

$$\text{RESULT} := \begin{cases} \text{"REVERSE"} & \text{if } \text{R32Q} = 1 \wedge \text{F32Q} = 0 \\ \text{"FORWARD"} & \text{if } \text{F32Q} = 1 \wedge \text{R32Q} = 0 \\ \text{"NO DECISION"} & \text{if } \text{R32Q} = 0 \wedge \text{F32Q} = 0 \end{cases}$$

$$\text{RESULT} = \text{"REVERSE"}$$