

SEL-2886

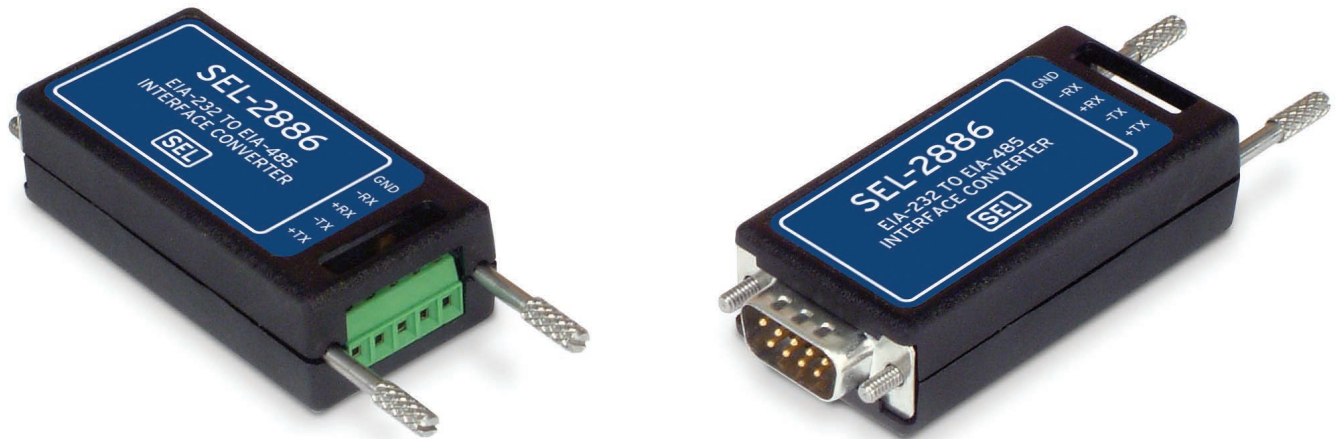

EIA-232 to EIA-485 Interface Converter

Easily Connect EIA-232 Serial Ports to EIA-485 Networks



Use the SEL-2886 Interface Converter for two- or four-wire EIA-485 networks.

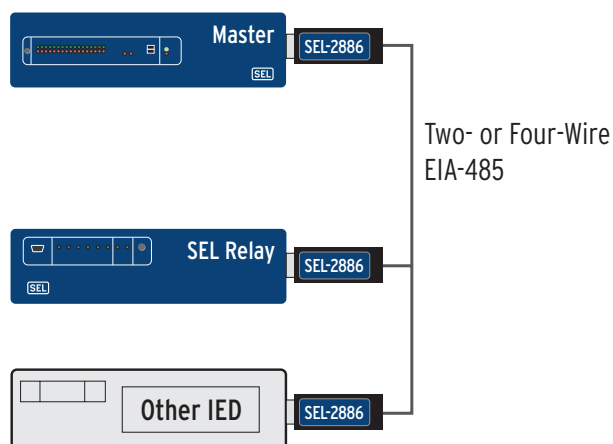

Features and Benefits

■ Flexible Application

Plugs directly onto a standard 9-pin EIA-232 serial connector. No special mounting is required. Receives 5 Vdc power from the host device via Pin 1 of the connector or from an external adapter via a jack. Apply to two- or four-wire networks at data rates up to 115,200 bps.

■ Improved Safety

Provides transformer isolation to 1500 Vrms.

■ Substation Quality

Operates over -40° to $+85^{\circ}\text{C}$ temperature range. Meets electric utility and industrial type-test standards.

Making Electric Power Safer, More Reliable, and More Economical®

SEL-2886 EIA-232 to EIA-485 Interface Converter

General Specifications

Installation

Select one of two methods to provide +5 Vdc to the SEL-2886:

- Pin 1—Many SEL devices have a jumper-selectable option to enable supply of +5 Vdc via Pin 1 of their EIA-232 ports.
- External Jack—A jack on the SEL-2886 accepts +5 Vdc from an external source. Two options to provide the power are the 230-0601 AC Power Adapter and the SEL-9321 Low-Voltage DC Power Supply.

Operation

Select operating modes using control (DIP) switches. Several modes key the transmitter on and off:

- EIA-422—Continuous full-duplex operation.
- RTS—Allows the host to control the transmitter with the RTS control line.
- Send Data Control (SDC)—The SEL-2886 detects activity of the transmit data line to start the transmitter, and after a predetermined idle time, the SEL-2886 turns the transmitter off. For SDC mode, use control switches to set the data speed to properly set the idle time to turn off the transmitter.

All of these modes are suitable for four-wire (full-duplex) networks. You can also use the RTS and SDC modes in two-wire (half-duplex) networks. For two-wire operation, jumper T+ to R+, T- to R-, and use a control switch to disable character echo.

Applications

Use the SEL-2886 in the following applications:

- Connect an SEL-2032 Communications Processor DNP3 port (Port 16) or Modbus® ports (Ports 16, 14, or 12) to a two- or four-wire multidropped EIA-485 network.
- Connect to an EIA-232 port on any device that is internally set to use DNP3, Modbus, SEL LMD (Distributed Port Switch), or another built-in, addressable protocol.

Technical Specifications

Data Rate

Up to 115200 bps

Power

5 Vdc ($\pm 5\%$) @ <100 mA

Operating Temperature

-40° to +85°C (-40° to +185°F)

EIA-232 Interface

DB-9 male connector

EIA-485 Interface

5-position terminal block

Substation- and Plant-Grade Equipment

Designed, built, and tested with the same practices, processes, and standards used for SEL protective relays, communications processors, and other products.

Related Products

AC Power Adapter

Use the 230-0601 AC Power Adapter for devices that cannot provide power via Pin 1 of the 9-pin connector. Connect to the power jack on the side of the SEL-2886.

SEL-9321 Low-Voltage DC Power Supply

Use the SEL-9321 for devices that cannot provide power via Pin 1. Mount the SEL-9321 on a wall, cabinet, or DIN rail. Connect to the power jack on the side of the SEL-2886.

SEL-C663 USB to Serial Port Cable

Connect an SEL-C663 cable to the USB port on a computer, and to an SEL-2886. The cable provides an EIA-232 serial port with power on Pin 1 that will operate the SEL-2886. Connect twisted-pair wiring between the SEL-2886 and the EIA-485 port on an SEL relay or other device when no EIA-232 port is available for PC access.



Pullman, Washington USA
Tel: +1.509.332.1890 • Fax: +1.509.332.7990 • www.selinc.com • info@selinc.com

© 2006–2015 by Schweitzer Engineering Laboratories, Inc. PF00150 • 20150323

