

SEL-751A

Feeder Protection Relay



2 ms arc-flash protection and feeder relay in one platform

- Combine light sensor inputs with high-speed overcurrent protection to achieve secure arc-flash protection in as fast as 2 ms.
- Enhance protection using voltage, frequency, and communications-based solution options.
- Use IEEE C37.118 synchrophasor measurements to accurately monitor wide-area power system conditions and to make decisions based on state measurements.



Functional Overview

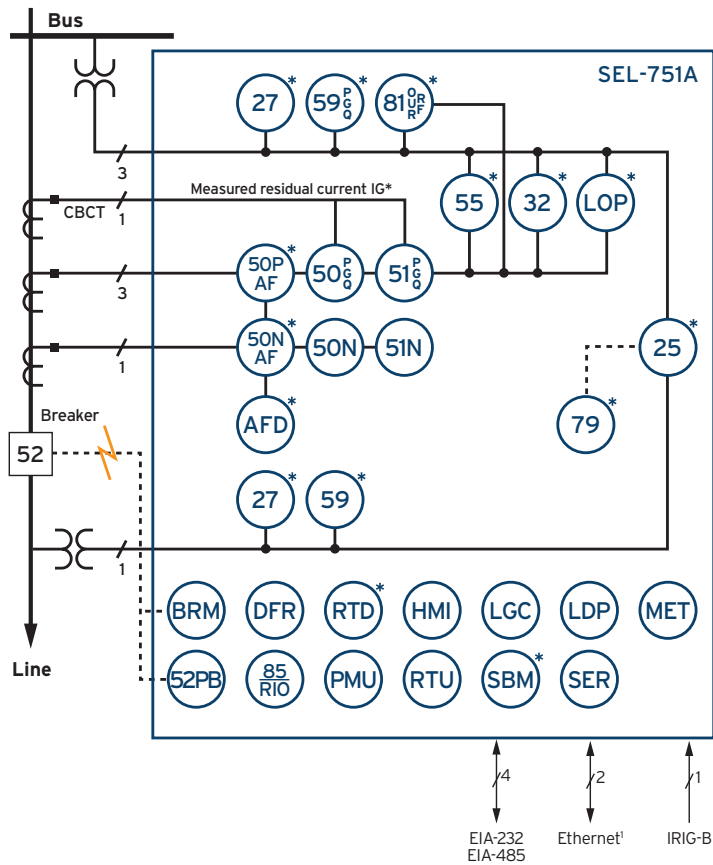

ANSI Numbers/Acronyms and Functions

25	Synchronism Check*
27	Undervoltage*
32	Directional Power*
50	Adaptive Overcurrent
50 (P,G,Q)	Overcurrent (Phase, Ground, Neg. Seq.)
50N	Neutral Overcurrent
50N AF	Arc-Flash Neutral Overcurrent*
50P AF	Arc-Flash Phase Overcurrent*
51 (P,G,Q)	Time Overcurrent (Phase, Ground, Neg. Seq.)
51N	Neutral Time Overcurrent
52PB	Trip/Close Pushbuttons
55	Power Factor*
59	Overvoltage*
79	Autoreclosing*
81 (O,U,R,RF)	Over-/Underfrequency (Rate, Fast Rate)*
85 RIO	SEL MIRRORING® Communications
AFD	Arc-Flash Detector*
BRM	Breaker Wear Monitor
DFR	Event Reports
LOP	Loss-of-Potential Logic*

Additional Functions

HMI	Operator Interface
LDP	Load Data Profiling
LGC	SELogic® Control Equations
PMU	Synchrophasors
RTD	Temperature
RTU	Remote Terminal Unit
SBM	Station Battery Monitor*
SER	Sequential Events Recorder

*Optional feature

¹Copper or fiber-optic



Key Features

Feeder Protection

Protect radial and looped distribution circuits with comprehensive protection, including time-overcurrent, autoreclosing, over-/undervoltage, frequency, and many more protection capabilities.

Arc-Flash Mitigation

Improve safety for personnel with optional arc-flash detection. The SEL-751A Feeder Protection Relay offers combined light and high-speed overcurrent detection for arc-flash events—the ideal solution for speed and security.

Automation and Control

Apply the SEL-751A on feeders to provide protection, automation, and control, all in one package. SELogic control equations support many automated applications without the need for additional automation controllers. The configurable front-panel buttons can replace conventional panel controls to simplify applications and wiring.

Event Analysis

Conduct post-event analysis more efficiently with detailed event records that combine oscillographic and digital information, making it easier to find the root cause. You can also add a satellite-synchronized time source, such as an SEL-2401 or SEL-2407® Satellite-Synchronized Clock, to conveniently align event information from multiple devices.

Situational Awareness

Improve situational awareness and asset utilization with IEEE C37.118 synchrophasor measurement via the serial port. Aggregated synchrophasor information from across your system can help you understand system trends, make decisions based on state measurement rather than state estimation, and perform post-event analysis.

Harsh Environments

Rely on the SEL-751A for protection and control applications even in harsh and hazardous environments. The SEL-751A is designed and tested to meet and exceed utility and industrial requirements. An operating temperature range of -40° to $+85^{\circ}\text{C}$ (-40° to $+185^{\circ}\text{F}$); Class 1, Division 2 approval; and optional conformal coating mean this relay will provide years of reliable service.



Product Overview

The 2 × 16 character LCD provides navigation, relay control, data, and diagnostics via default messages or up to 32 customizable display messages.



Programmable front-panel LEDs with user-configurable labels alert operators to faulted phases and element operation.

Programmable operator pushbuttons with user-configurable labels allow front-panel customization.

Power supply options include 24–48 Vdc or 110–250 Vdc/110–240 Vac.

A wide variety of communications protocols and media provide flexibility to communicate with other devices and control systems.

The optional fiber-optic serial port provides quick and easy engineering access.

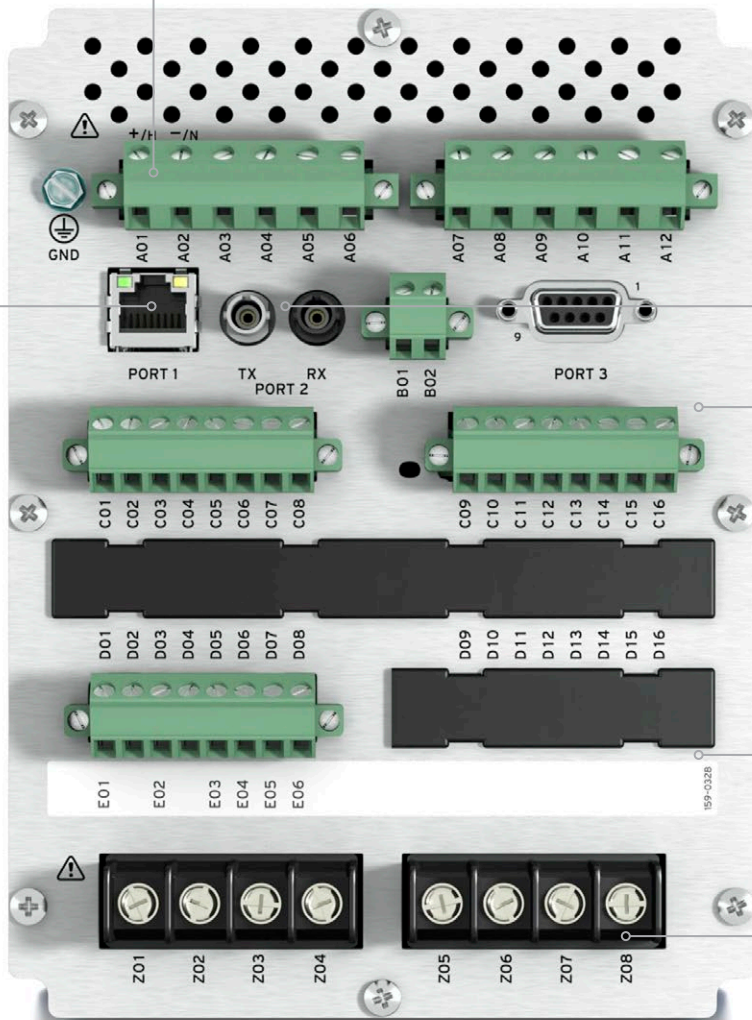

Card slots include positions for optional I/O, a voltage input card, or an arc-flash detection card with sensors that help improve safety and prevent damage.

Phase current and optional phase voltage inputs are on one card, freeing up space for additional SELECT™ I/O card options.

Reduce Arc-Flash Hazards

Combine light-sensing technology with fast overcurrent protection to provide high-speed arc-flash detection as fast as 2 milliseconds without false tripping.

Fast and secure arc-flash protection reduces the incident energy of arc-flash events. SEL-751A Relays have integration and communications features for secure

remote access. With wireless or remote communications, you can keep out of the danger zone completely while gathering important real-time and historical data from the relays to coordinate protection for faster clearing times.

Clear-jacketed fiber sensors detect light from the arc flash over the entire length of the fiber loop. This type of sensor is ideal for large areas, such as busbars.



Easily mounted point sensors detect light from the arc flash.

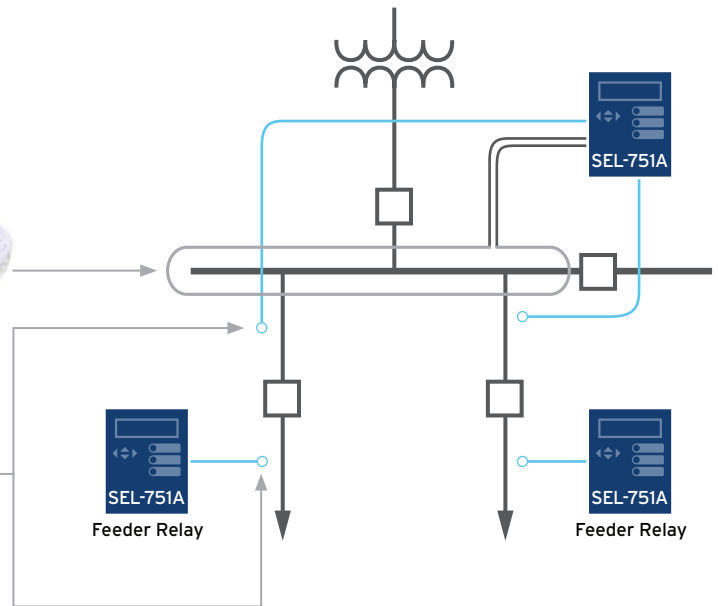

Coordinate Protection

Use SEL MIRRORED BITS communications to coordinate upstream protection if a fault occurs. Coordination and fast-bus trip schemes allow short delays (two or three cycles) for backup protection, reducing arc-flash energy.

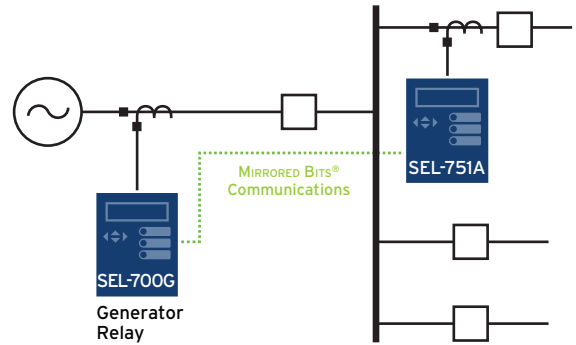

Stay Outside the Danger Zone

Remotely obtain metering, event, and maintenance information from the relay with Ethernet or serial communications. Optional delayed breaker tripping or closing via pushbuttons allows personnel to move to a safe distance.

If you must be in the danger zone, know the dangers and wear appropriate personal protective equipment. If you do not know the arc-flash ratings and zones for your gear, the SEL Engineering Services team can provide professional arc-flash hazard studies and practical approaches to mitigate arc-flash risks.

Restricted Approach Boundary

An approach limit at a distance from an exposed energized electrical conductor or circuit part within which there is an increased likelihood of electric shock, due to electrical arc-over combined with inadvertent movement.

Limited Approach Boundary

An approach limit at a distance from an exposed energized electrical conductor or circuit part within which a shock hazard exists.



Remote Access

Ethernet or Serial

Arc-Flash Boundary

When an arc flash hazard exists, an approach limit from an arc source at which incident energy equals 1.2 cal/cm^2 (5 J/cm^2) for one second*.

This boundary can be greater or less than the limited approach boundary, based on the results of the arc-flash assessment.

Arc-rated PPE is required when within the arc-flash boundary.

*According to the Stoll skin burn injury model, the onset of a second degree burn on unprotected skin is likely to occur at an exposure of 1.2 cal/cm^2 (5 J/cm^2) for one second.

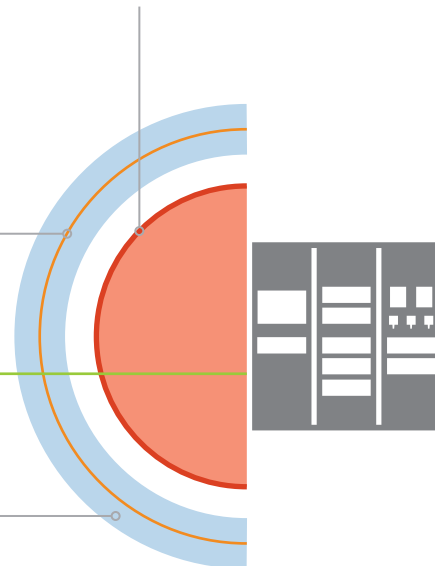

Applications

Feeder Protection

Provide comprehensive protection capabilities, including time-overcurrent, over-/undervoltage, autoreclosing, frequency, and many more.

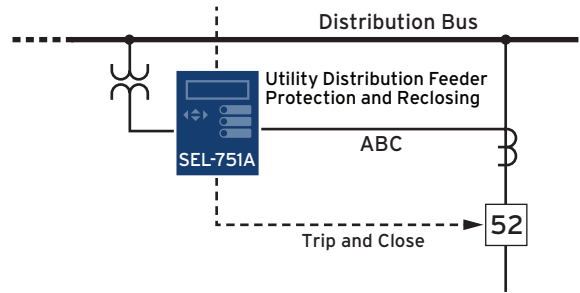

Industrial Feeder Protection

Implement overcurrent, voltage, and frequency protection for industrial and commercial feeders. The addition of a core-balanced CT detects ground faults and provides an added level of protection.

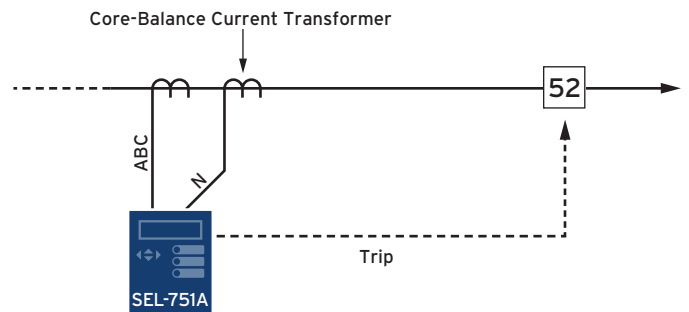

Arc-Flash Mitigation

Improve safety and prevent damage with arc-flash detection in the SEL-751A. You can choose point sensors, loop sensors, or a combination to protect a wide variety of switchgear configurations.

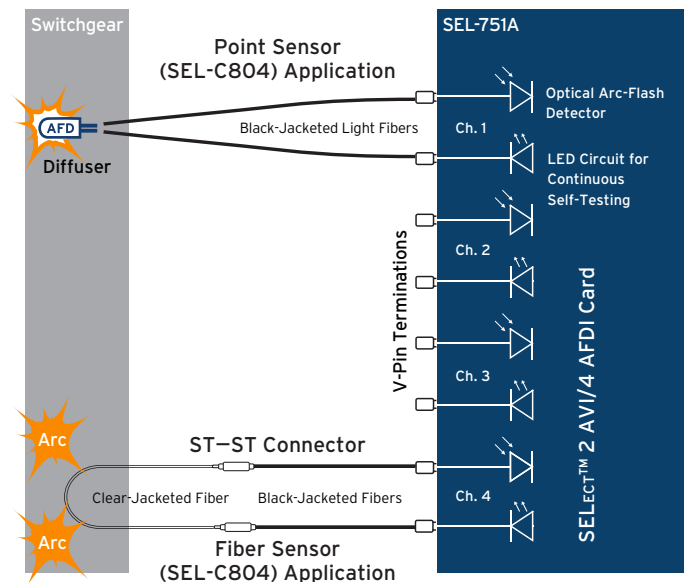

Easy to Set and Use

Set, Monitor, and Control the SEL-751A With ACSELERATOR QuickSet® SEL-5030 Software

- Save engineering time, and simplify device setup. QuickSet allows you to communicate with the SEL-751A through any ASCII terminal or with the software graphical user interface.
- Develop settings offline with a menu-driven interface and completely documented help screens. By copying existing settings files and modifying only application-specific items, you can decrease the installation time.
- Simplify the setting procedure with rule-based architecture to automatically check interrelated settings. QuickSet highlights out-of-range or conflicting settings for correction.

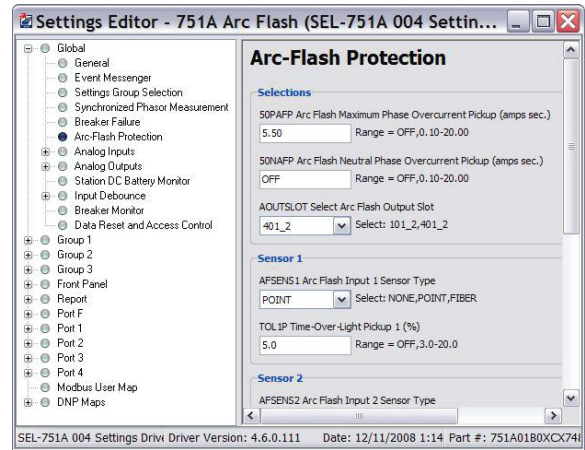

Retrieve and Display Event Reports With ACSELERATOR TEAM® SEL-5045 Software

- View event report oscillograms as a plot of magnitude versus time. You can select analog and digital points to build a custom display.
- Analyze arc-flash events using the light intensity and phase current waveforms recorded during an arc fault.
- Display phase and symmetrical component phasors. The phasor view of electrical data can help you better understand asymmetrical three-phase faults. You can also build a custom plot using per-phase and symmetrical component sequence currents and voltages.
- Retrieve event reports using serial or Ethernet communications links.

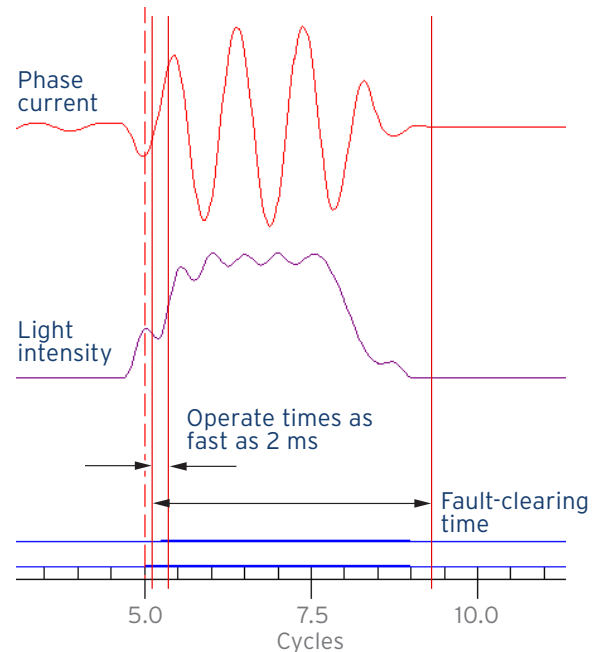

Mounting and Enclosure Options

Mount the SEL-751A into multiple locations using our complete line of mounting and enclosure options. Panel-mount, rack-mount, wall-mount, indoor, or outdoor configurations provide solutions for any application. The optional mounting kits do not require any cutting or drilling, making the replacement of existing protection quick and easy.

Visit www.selinc.com/applications/mountingselector to see the complete selection of mounting and enclosure kits.

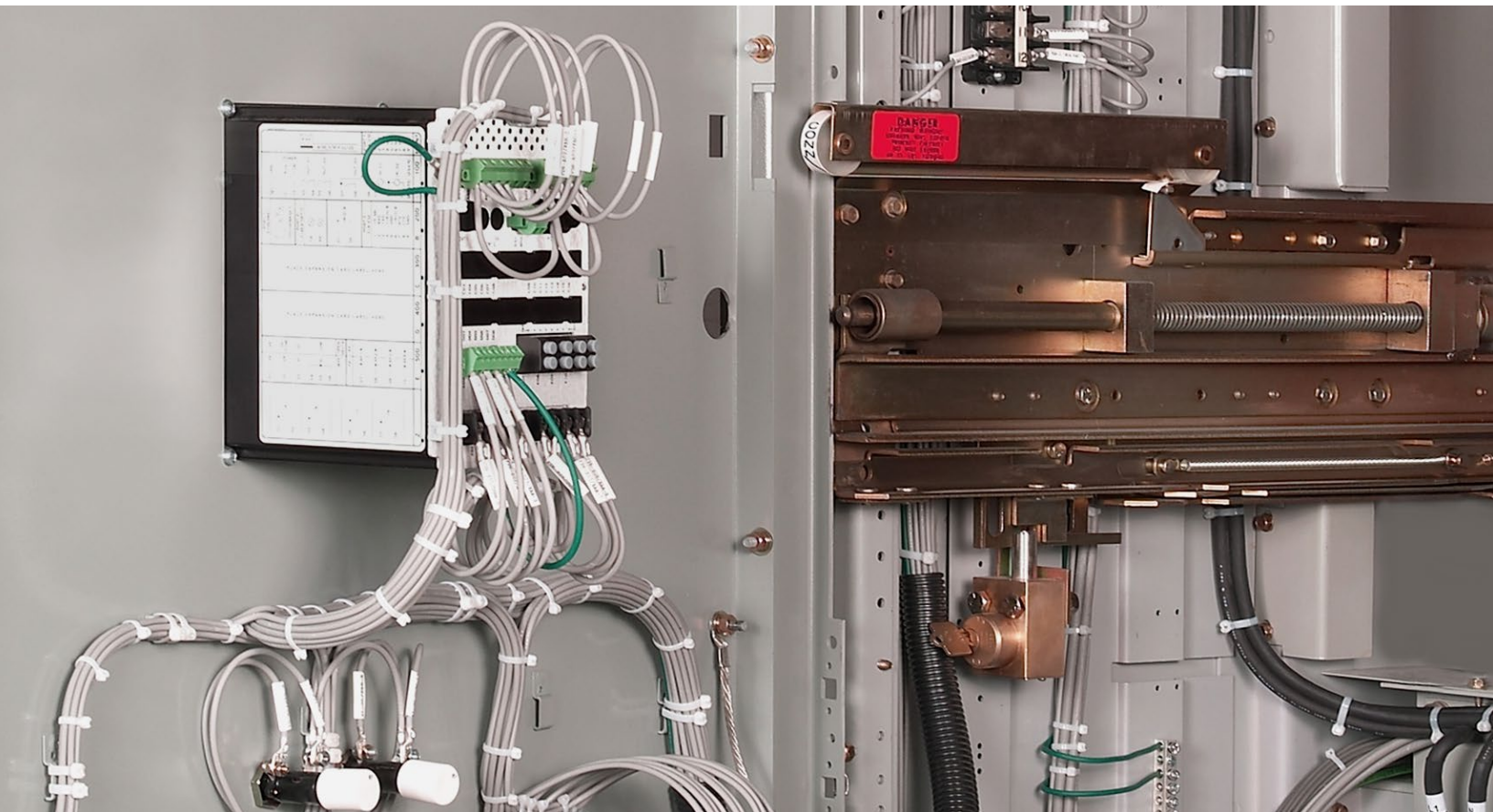

SEL-751A Specifications

General

AC Current Inputs	5 A, 1 A, 50 mA, or 2.5 mA (high sensitivity) secondary, depending on model
AC Voltage Inputs	300 Vac continuous, 600 Vac for 10 seconds
Output Contacts	The relay supports Form A, B, and C outputs.
Optoisolated Control Inputs	DC/ac control signals: 250, 220, 125, 110, 48, or 24 V
Frequency and Phase Rotation	System frequency: 50, 60 Hz Phase rotation: ABC, ACB Frequency tracking: 15–70 Hz (requires ac voltage inputs)
Arc-Flash Time-Overlight® Elements (TOL1–TOL4)	Pickup time: 2–5 ms Dropout time: 1 cycle
Communications Media	Ethernet 10/100BASE-T; Ethernet 100BASE-FX; single or dual Ethernet ports; EIA-232 serial; EIA-485 serial; fiber-optic or serial multimode ST connectors
Communications Protocols	MIRRORED BITS communications; IEC 61850; Modbus RTU/TCP; DNP3 serial and LAN/WAN; DeviceNet; Telnet; File Transfer Protocol (FTP); Simple Network Time Protocol (SNTP); simple and compressed ASCII; extended Fast Meter and Fast Operate; Fast SER; Event Messenger; IEEE C37.118 synchrophasors (via serial port only)
Power Supply	110–250 Vdc or 110–240 Vac Input voltage range: 85–300 Vdc or 85–264 Vac 24–48 Vdc Input voltage range: 19.2–60 Vdc
Operating Temperature¹	–40 to +85°C (–40 to +185°F)

¹LCD contrast is impaired for temperatures below –20°C (–4°F) and above +70°C (+158°F).

SEL SCHWEITZER ENGINEERING LABORATORIES

Making Electric Power Safer, More Reliable, and More Economical
+1.509.332.1890 | info@selinc.com | selinc.com

© 2020 by Schweitzer Engineering Laboratories, Inc.
PF00154• 20201210

