



SEL-311L Line Current Differential Protection and Automation System

Differential Relays With Alpha Plane Restraint Provide Superior Security, Speed, and Sensitivity



Major Features and Benefits

- **Synchrophasors.** Improve operator awareness of system conditions. Use real-time data to view load angles, improve event analysis, and provide state measurements.
- **Security and Reliability.** Provide security for CT saturation and channel asymmetry by using the alpha plane restraint characteristic.
- **Protection Sensitivity.** Provide sensitivity without sacrificing security during external faults through the use of negative-sequence current differential and alpha plane restraint.
- **Protection Speed.** Subcycle operating times at only four times minimum pickup for phase elements.
- **Single-Pole Tripping.** Improve system stability with optional single-pole tripping by differential and Zone 1 distance elements.
- **Full-Featured Backup Protection.** Standard backup protection includes: four zones of distance protection, directional overcurrent elements, and a four-shot reclose logic system.
- **Easy to Apply.** Select CT ratios and channel ID and the relay is ready to be used on most differential applications. Use application settings for simplifying setting requirements.
- **Communication Security.** True hot standby communications for no loss or degradation in protection during single channel failure. Isolation of 1.5 kV on electronic differential communication circuits. IEEE C37.94 fiber to multiplexer compatible. Multiple channel paths do not require the same baud rate or channel delay.
- **Three-Terminal Application.** Apply the SEL-311L on three-terminal lines without compromising protection even on loss of a single differential channel.
- **Mismatched CTs.** Set the CT ratio for all connected terminals. The alpha plane restraint characteristic prevents misoperation due to mismatched characteristics such as voltage class or burden.
- **Automation.** Equip the SEL-311L with optional dual failover Ethernet communications for Telnet, FTP, read-only web server, and IEC 61850 communications support.

Functional Overview

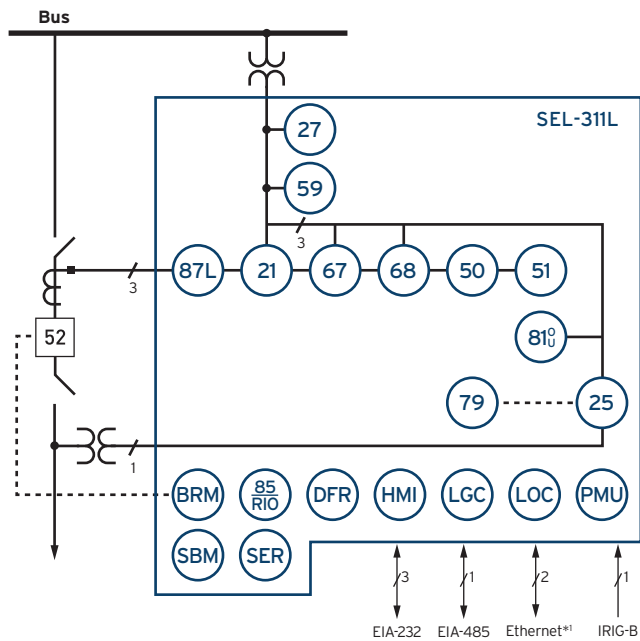

Figure 1 Functional Diagram

ANSI NUMBERS/ACRONYMS AND FUNCTIONS

21	Phase and Ground Distance
25	Synchronism Check
27/59	Under- and Overvoltage
50	Overcurrent
51	Time-Overcurrent
67	Directional Overcurrent
68	Out-of-Step Block/Trip
79	Single- and Three-Pole Reclosing
81 (O, U)	Over- and Underfrequency
85 RIO	SEL MIRRORING BITS Communications
DFR	Event Reports
HMI	Operator Interface
LGC	SELogic Control Equations
MET	High-Accuracy Metering
PMU	Synchrophasors
SER	Sequential Events Recorder

ADDITIONAL FUNCTIONS

BRM	Breaker Wear Monitor
LDE	Load Encroachment
LOC	Fault Locator
SBM	Station Battery Monitor

¹ Copper or Fiber Optic * Optional Feature

Protection Features

The SEL-311L contains an advanced line current differential system that is easy to set and apply, while still giving subcycle operation and superior fault resistance coverage. It is suitable for protection of any transmission line or underground cable where digital communications, in the form of either a 56/64 kb channel or a dedicated fiber-optic interface is available. Enable as many as four zones of phase and ground mho distance backup elements plus four zones of ground quadrilateral distance elements. These distance elements, together with overcurrent functions, may be applied in communications-assisted and stepped-distance protection schemes (see *Figure 1*).

Predefined configurations for typical applications are included in the relay settings. These configurations allow for greatly reduced settings for many line configurations, with or without potential transformers.

Protection Elements

The SEL-311L differential elements compare phase and sequence components from each line terminal, as illustrated in *Figure 2*. Because line charging current has a very low negative-sequence component, negative-sequence current differential protection allows for high

sensitivity without compromising security. The phase elements provide high-speed protection for severe or balanced faults. This allows high-speed operation even under heavy load flow conditions when system stability may be critical.

The innovative differential protection in the SEL-311L checks the vector ratio of the local (\vec{I}_L) and remote (\vec{I}_R) currents in a complex plane, known as the alpha plane, as shown in *Figure 3*, *Figure 4*, *Figure 6*, and *Figure 7*. For load and external faults, with no CT or communication errors, the vector ratio of remote current to local current will be -1 or $1 \angle 180^\circ$. Errors introduced from CTs or nonequal communications path delays cause the ratio to appear at different locations within the complex ratio plane. The SEL-311L restraint characteristic improves on prior systems. The SEL-311L restraint region surrounds the ideal external fault and load current point allowing for errors in both magnitude and phase angle. CT saturation, channel asymmetry, and other effects during faults outside the protected zone produce shifts in the magnitude and angle of the ratio. The restraint characteristic provides proper restraint for these conditions and still detects high-impedance faults and “outfeed” faults that occur within the protected zone. The restraint region is adjustable both in angular extent and radial reach.

The differential protection algorithms are insensitive to CT saturation effects due to different CT characteristics at the line ends or remnant CT flux. This prevents tripping on through faults and allows the use of existing CTs at each line end. The SEL-311L current connections

add very little burden, which allows line current differential protection to be added to multiuse CTs without degradation of accuracy (see *Figure 5* and *Figure 6*).

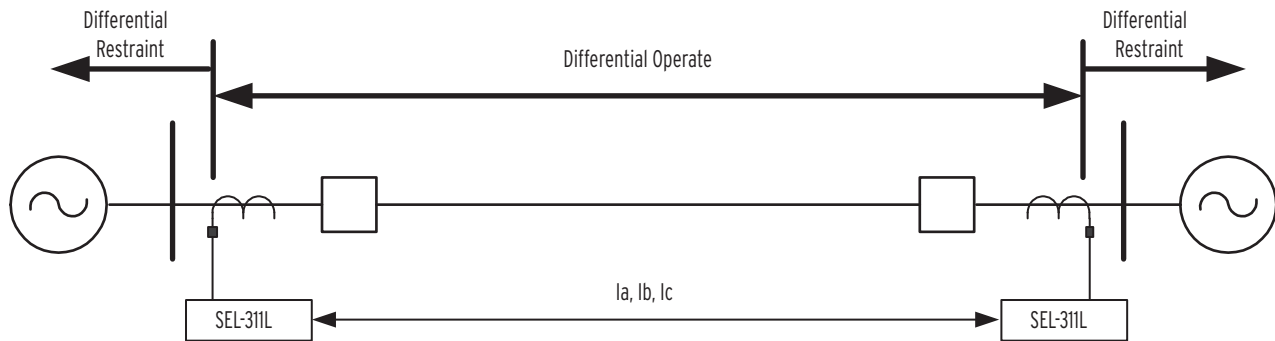

Figure 2 Differential Element Operate and Restraint Regions

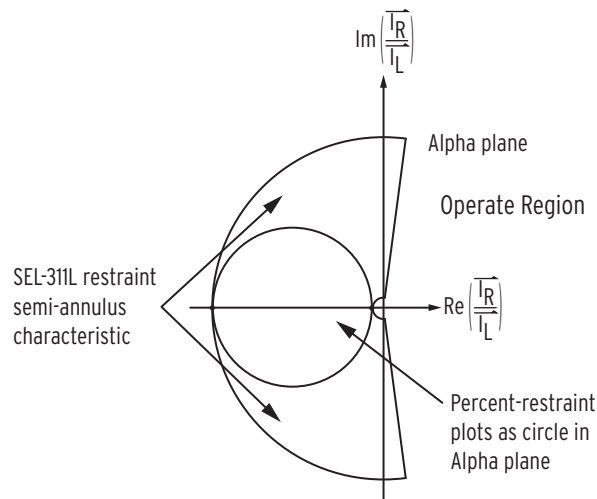

Figure 3 Operate and Restraint Regions in the Alpha Plane

For characteristics with the same sensitivity, SEL-311L Relays have greater security than percent-restraint, as seen in this alpha plane comparison.

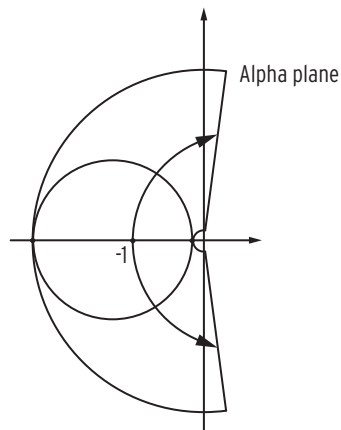

Figure 4 Channel Asymmetry in the Alpha Plane

Communications channel asymmetry causes errors in angle and is easily handled by the SEL-311L semi-annular restraint characteristic. Percent-restraint is less secure.

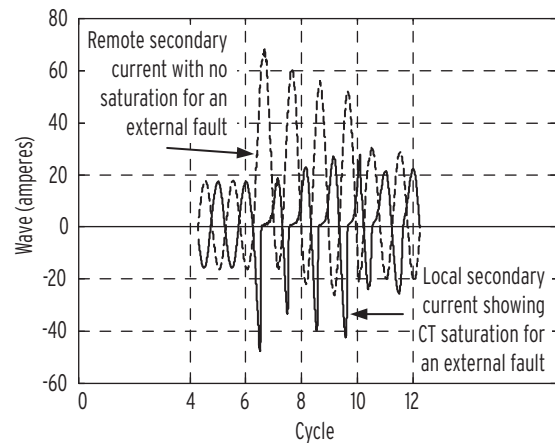

Figure 5 Effect of Current Transformer Saturation in Wave Form

Secondary CT currents resulting in false differential current due to CT saturation at one end of the protected line.

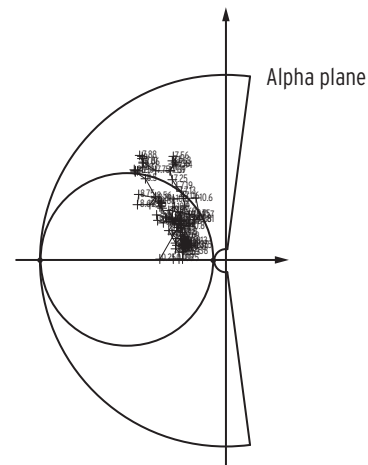

Figure 6 Effect of Current Transformer Saturation in Alpha Plane

For the CT saturation shown, the current ratio trajectory plots outside the percent-restraint circle while remaining securely inside the SEL-311L semi-annular restraint characteristic. Percent-restraint could misoperate for this fault.

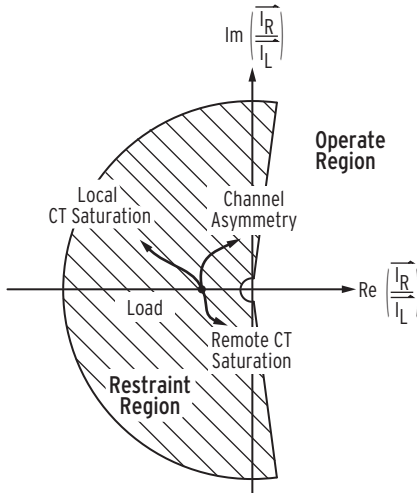

Figure 7 System Conditions in the Alpha Plane

Alpha Plane Restraint Provides Security, Even With CT Saturation

The SEL-311L restraint characteristic advances the state of the art in transient security for differential relays. CT saturation during external faults moves the remote to local current ratio plot in the alpha plane. The restraint characteristic accommodates a large degree of CT saturation.

The following equation gives the CT selection criteria for a two-terminal application:

$$150 \geq (X/R + 1) \cdot I_F \cdot Z_B$$

where:

- X/R is system X/R ratio
- I_F is secondary fault current, per unit of nominal secondary current
- Z_B is CT burden, per unit of rated secondary burden

To avoid CT saturation entirely, select and apply the CT such that

$$20 \geq (X/R + 1) \cdot I_F \cdot Z_B$$

Notice that the SEL-311L remains secure even when the CT is over-burdened 7.5 times worse than the case which avoids all CT saturation.

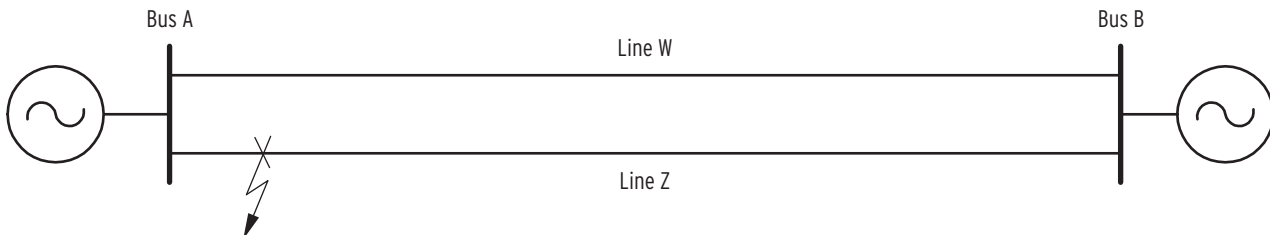

Figure 10 Single-Pole Tripping Diagram

Sensitivity and High Speed

The SEL-311L provides sensitive negative- and zero-sequence differential elements, as well as high-speed phase current differential elements. Set negative- and zero-sequence differential elements below load or line charging current without risk of misoperation. The graph in Figure 9 shows the average operate time, including high-speed outputs, for the phase differential units. For improved security on uneven pole operation, the sequence units operate approximately 2 cycles slower.

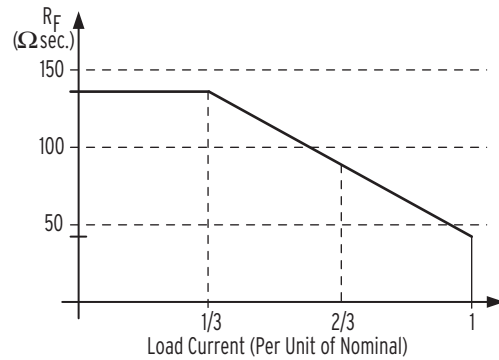

Figure 8 Ground Fault Sensitivity

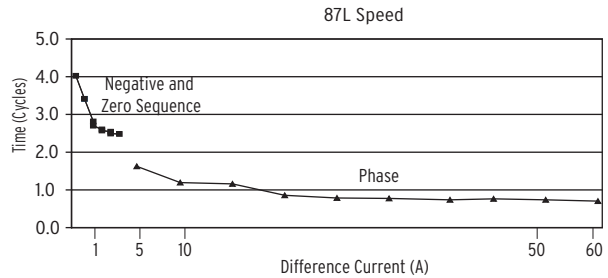

Figure 9 Current Differential Element Trip Times

Single-Pole Tripping

In this example two-line system (Figure 10) we can look at the stability curve to see the power transfer capability under different system conditions. In cases where systems must operate near stability limits, it is clear that the optional single-pole tripping capability of the SEL-311L will improve the transient stability.

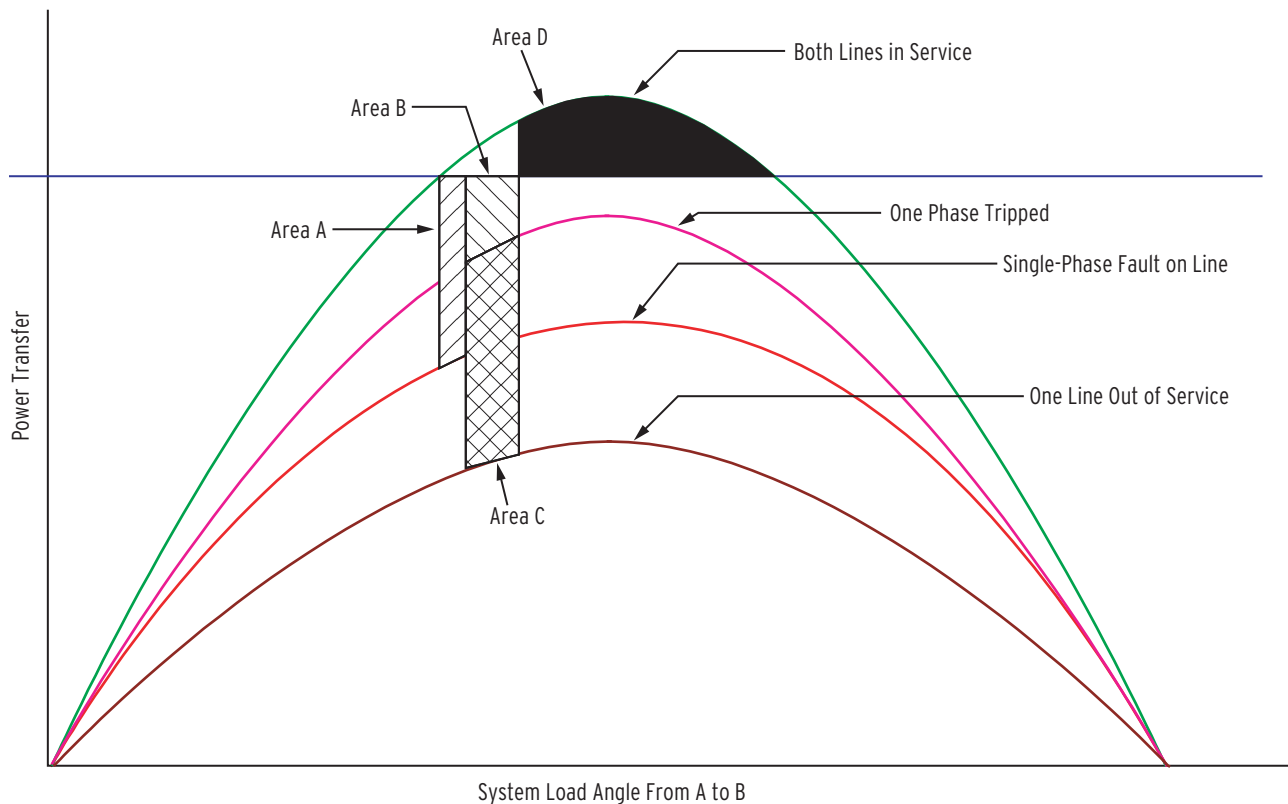

Figure 11 Equal Area Curve

Single-pole tripping improves stability as illustrated by the difference between Area B (for single-pole trips) and Area B + C (for three-pole trips) (*Figure 11*). The difference in these two areas is the extra stabilizing momentum available when single-pole tripping is used as compared to three-pole tripping.

The high-speed tripping of the SEL-311L complements the single-pole tripping by minimizing the size of Area A. The operating time of the SEL-311L, including output time, is approximately 0.75 cycles for a severe fault.

Full-Scheme and/or Current-Only Backup Protection

Full-Scheme Backup Protection

The SEL-311L includes all of the protection elements in the SEL-311C Relay. A complete and independent distance and directional overcurrent system is included for use if potential transformers are available (see *Figure 12*). These elements run on a separate processor platform using separate contacts and firmware. Failure of either the 87L channel or processing hardware does not affect backup protection. Both step-distance and commu-

nications-assisted protection are available. Transmit the permissive trip, direct trip, or block trip signal by using the current differential channel, MIRRORING BITS[®] communications on a separate serial port, or via contact to channel equipment.

Backup protection maintains excellent sensitivity using patented Best Choice Ground Directional[™] protection. All the features of the SEL-311C, such as load-encroachment, out-of-step, loss-of-potential detection and blocking, and CCVT transient detection are also included.

Current-Only Backup Protection

Apply phase and ground overcurrent backup protection elements in the SEL-311L. When the “Current-Only” Application Setting is used, these are the only backup elements that will be displayed for setting.

Three steps of phase and four steps of ground and negative-sequence instantaneous/definite time-overcurrent protection are included. Inverse-time phase, ground, and negative-sequence overcurrent elements are also included. If desired, backup elements can be enabled only after a communications failure.

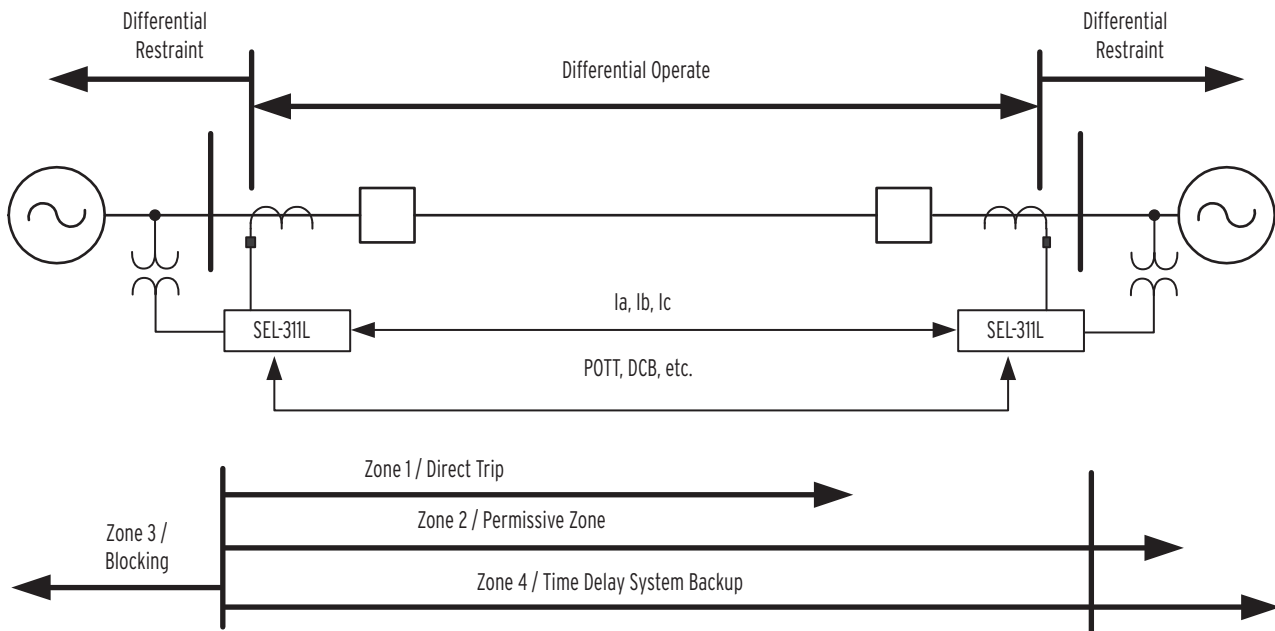

Figure 12 Full Scheme Backup Protection

Synchphasors

The SEL-311L now includes phasor measurement technology that provides synchrophasor measurements throughout a power system. This technology in a protective relay reduces or eliminates incremental installation and maintenance costs while leaving system reliability unaffected. Incorporate present and future synchrophasor technology control applications without much effort into the same devices that protect and control the power system.

High-Speed Trip Contacts Interrupt Trip Current

Six high-speed, high-current interrupting contact outputs are controlled directly by the line current differential processor. These contacts can interrupt trip currents should the breaker auxiliary contacts fail to open. Backup protection can use the same high-speed contact outputs, passing backup trip decisions through the current differential processor (see *Figure 13*).

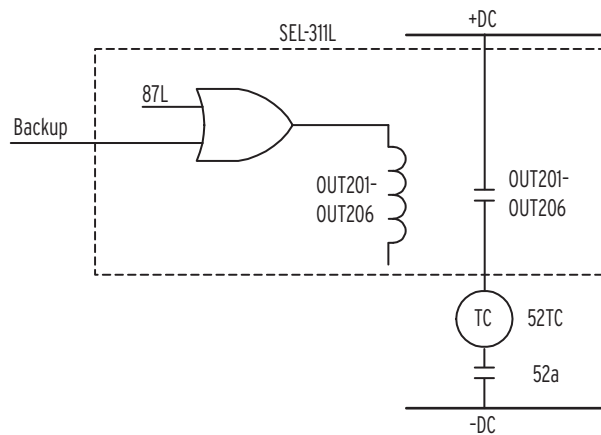

Figure 13 Combined Distance and Current Differential Protection

To maintain backup protection independent of line current differential protection, use standard contacts (eight included) controlled by the backup protection processor for backup tripping (see *Figure 14*).

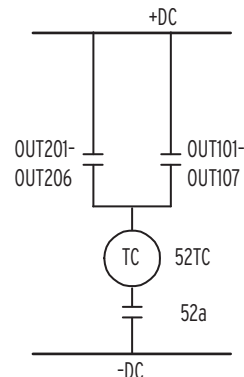

Figure 14 Segregated Differential and Backup Tripping

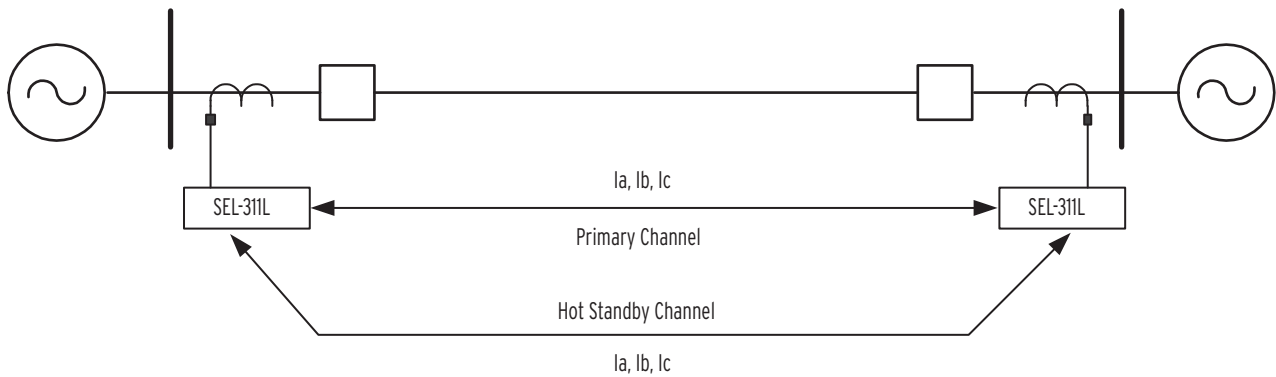

Figure 15 Dual Channel Hot Standby Communications

Dual Channel, Hot Standby Communications

Use one or two current differential communications channels between the line ends. For a two-terminal line, the redundant channel is in hot standby mode until the primary channel fails (see *Figure 15*). There is no interruption of protection or delay in tripping, even if a fault occurs simultaneously with the loss of one communications channel (see *Figure 16*).

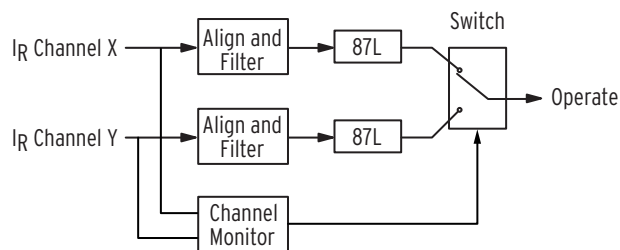

Figure 16 True Hot Standby

Dual Communications and Dual Differential prevent loss or degradation of protection during channel failure.

The relay continuously monitors both channels for correct data transmission and channel delay. Channel quality reports available from the relay include short and long term unavailability, and round trip channel delay. Use this information to accurately assess protection and communications system reliability and make appropriate changes for maximum system reliability.

Channel Requirements

The SEL-311L has options for the following channel interfaces (select one or two):

- G.703 codirectional to multiplexer
- EIA-422 to multiplexer for a 64 kbps or 56 kbps channel
- 1300 nm single-mode (120 km) fiber
- 1550 nm single-mode (120 km) fiber
- IEEE C37.94-compatible multimode fiber to multiplexer
- IEEE C37.94-compatible modulated 1300nm single-mode fiber to multiplexer

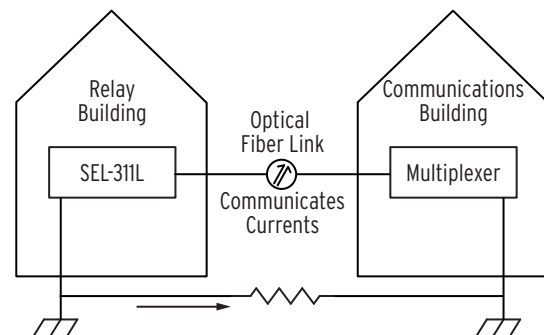

Figure 17 IEEE C37.94-Compatible

The SEL-311L Relay with an IEEE C37.94-compatible standard fiber interface. It provides a direct fiber-optic interface between the relay and multiplexer to prevent communication errors, equipment damage, and hazardous conditions due to ground potential rise.

```

=>>>COMM Y L <Enter>
SEL-311L                               Date: 05/26/01   Time: 09:27:03.269
EXAMPLE: BUS B, BREAKER 3

FID=SEL-311L-R100-V0-Z001001-D20010625   CID=BAFD
Summary for 87L Channel Y
Channel Status Alarms
ROKY = 1   DBADY = 0   RBADY = 0   AVAY = 0

For 05/24/01 13:37:01.631 to 05/26/01 09:27:04.248

COMMUNICATION LOG SUMMARY                COMMUNICATION STATISTICS
# of Error records 29                      Last error          Data Error
Data Error        20                      Longest failure     4.685 sec.
Dropout           9                       Lost Packets, prev. 24 hours 407
Test Mode Entered 0                      One Way Delay (Ping-Pong) 0.4 msec.

#   Error   Date      Time          Recovery      Date      Time          Duration Cause
1   05/26/01 09:23:54.041 05/26/01 09:23:54.042 0.001 Data Error
2   05/26/01 09:23:53.888 05/26/01 09:23:54.040 0.152 Dropout Error
3   05/26/01 09:23:53.885 05/26/01 09:23:53.888 0.003 Data Error
4   05/26/01 09:23:53.882 05/26/01 09:23:53.885 0.003 Dropout Error
.
.
.
27  05/24/01 13:37:04.688 05/24/01 13:37:04.689 0.001 Data Error
28  05/24/01 13:37:00.003 05/24/01 13:37:04.688 4.685 Dropout Error
29  05/24/01 13:37:00.000 05/24/01 13:37:00.003 0.003 Data Error
  
```

Figure 18 COMM Command Report

The SEL-311L Relay communications monitor reports performance of all 87L channels and MIRRORED BITS communications channels. Review these reports to optimize communications.

Tapped Load Application

The SEL-311L coordinates with tapped loads. A difference-current ANSI or IEC overcurrent protection curve, as shown in *Figure 19*, coordinates with the tapped load protection. This prevents loss of the line for cases of a fault on the tap, while still providing differential measurements of the protected line to give the fastest operation possible. Implement either fuse-saving or trip-saving

schemes. For example, select high-speed, sensitive protection for the initial shot and then delayed tripping on a subsequent reclose operation to allow a fuse on the tapped line to blow if the fault is still present. This can be modified to accommodate the user's operation practices and provide the best possible service for the end customers. This feature is applicable to two- and three-terminal lines.

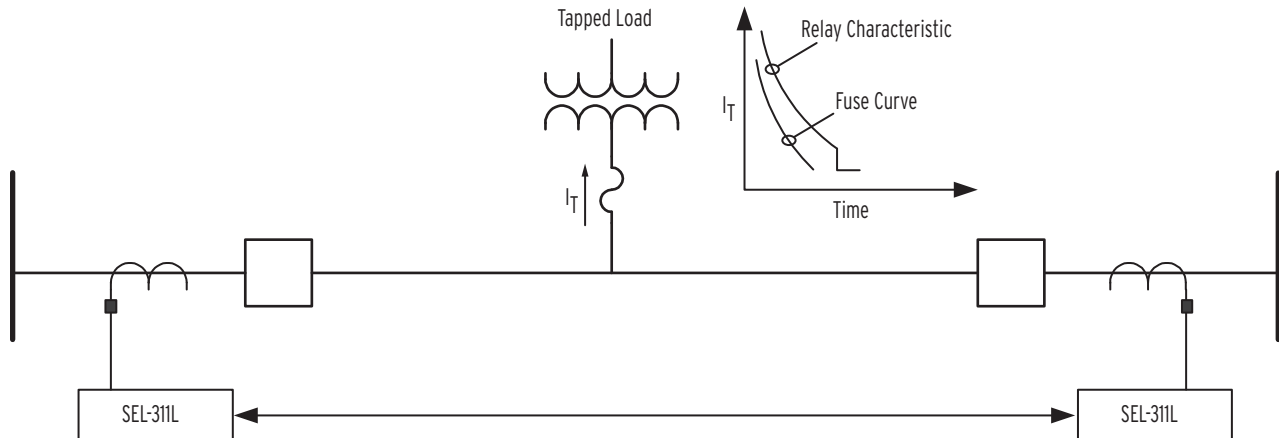

Figure 19 Tapped Load Coordination

Relays determine current at the tap point. Overcurrent elements use that current to coordinate with tap protection. Use phase current, negative-sequence current, and zero-sequence current for optimal protection.

Three-Terminal Lines

The SEL-311L protects three-terminal lines in either a peer-to-peer configuration by using two channels connected to each relay, as shown in *Figure 20*, or in a leader-remote arrangement when only one relay is connected to two channels. The leader relay has line current information from all terminals. It sends a trip signal to the remote units when it determines there is a fault on the line.

Reclosing

The SEL-311L includes a four-shot recloser. Internal element status or external inputs can condition the recloser to match your practice:

- Reclose initiate (e.g., breaker status, fault type, trip).
- Drive-to-lockout or last shot (e.g., input from manual or SCADA open).
- Skip shot (use 27/59 elements, fault current magnitude).
- Stall open-interval timing.
- Separate times to reset from cycle or lockout.

The recloser shot counter can control which protective elements are used in each reclose interval for fuse-saving or fuse-coordination of tapped or downstream loads. Front-panel LEDs track the recloser state: Reset (RS) and Lockout (LO).

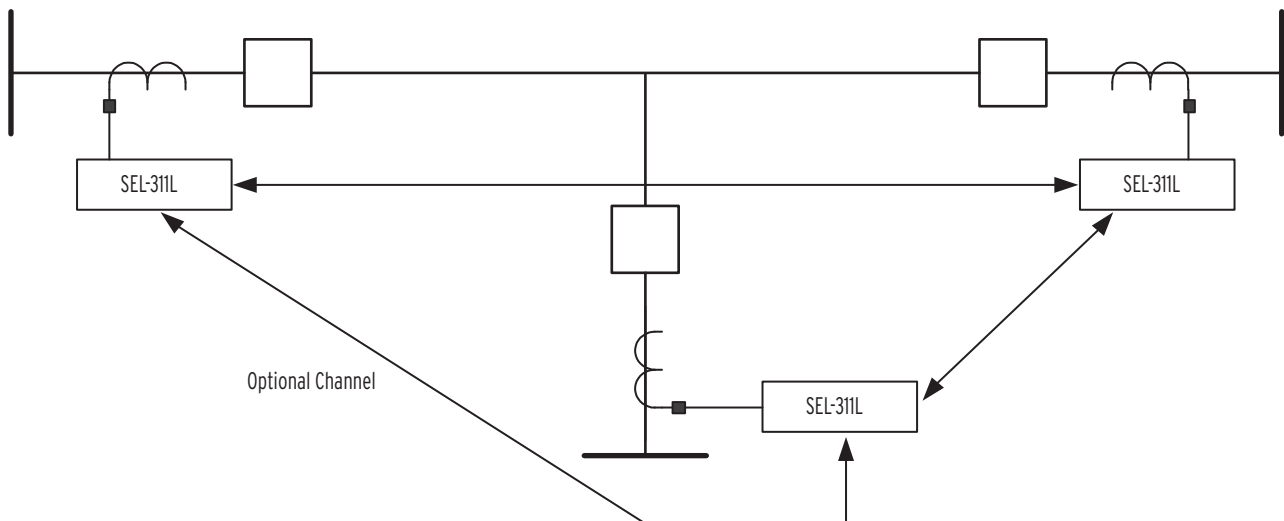

Figure 20 Three-Terminal Line Protection Communications Connections

Bus Stub Logic

Bus stub protection is enabled by input or SELOGIC control equation.

- No analog data are sent to the remote terminal
- Analog data received from the remote terminal are ignored
- Differential transfer trips are disabled

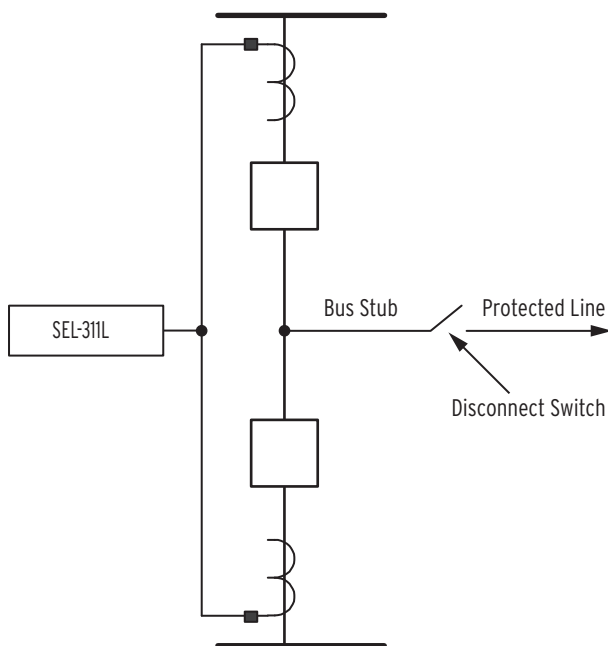

Figure 21 Automatic Bus Stub Protection

Fault Locator

If potentials are applied, the SEL-311L provides an accurate fault location calculation even during periods of substantial load flow. The fault locator uses fault type, replica line impedance settings, and fault conditions to calculate fault location without communications channels, special instrument transformers, or pre-fault information. This feature contributes to efficient dispatch of line crews and fast restoration of service.

The relay provides fault location information on the front panel, in the event reports, and in event summaries.

Six Independent Setting Groups

The relay stores six groups of settings. Select the active setting group by contact input, serial port or front-panel command, or other programmable conditions. Use these setting groups to cover a wide range of protection and control contingencies. Selectable setting groups make the SEL-311L ideal for applications requiring frequent setting changes and for adapting the protection to changing system conditions. Selecting a group also selects logic settings.

Program group selection logic to adjust settings for different operating conditions, such as station maintenance, seasonal operations, emergency contingencies, loading, source changes, and adjacent relay setting changes.

Relay and Logic Settings Software

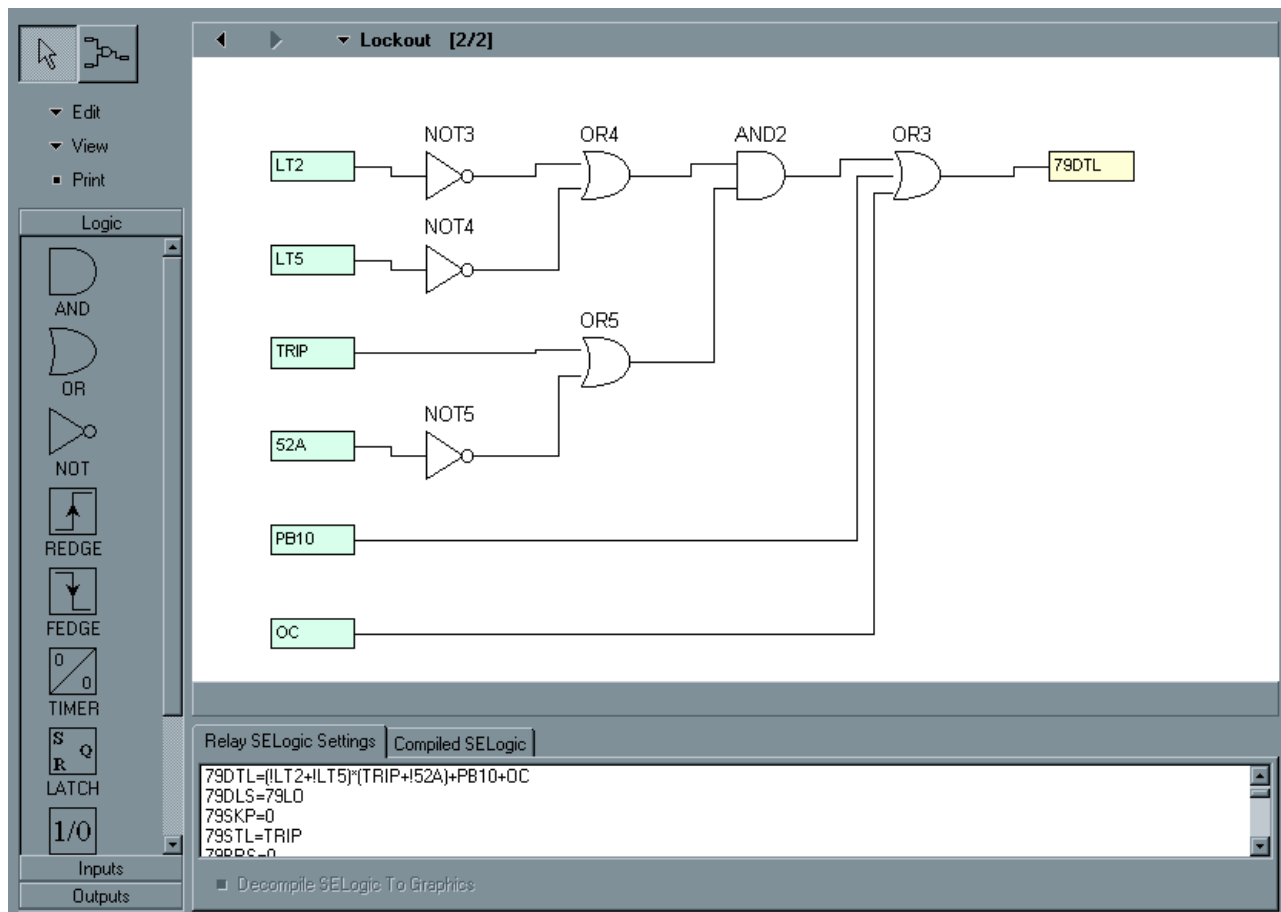

Figure 22 QuickSet Screen

The ACSELERATOR QuickSet® SEL-5030 Software program uses the Microsoft Windows operating system to simplify settings and provide analysis support for the SEL-311L.

Use QuickSet to create and manage relay settings:

- ▶ Develop settings off-line with an intelligent settings editor that only allows valid settings.
- ▶ Create SELOGIC control equations with a drag and drop graphical editor and/or text editor.
- ▶ Use on-line help to assist with configuring proper settings.
- ▶ Organize settings with the relay database manager.
- ▶ Load and retrieve settings by using a simple PC communications link.

Use QuickSet to verify settings and analyze events:

- ▶ Use the logic simulator to test setting schemes with user or event report input stimulus. (Use for training, too!)
- ▶ Analyze power system events with the integrated waveform and harmonic analysis tools.

Use QuickSet to aid with monitoring, commissioning, and testing the SEL-311L:

- ▶ Use the HMI to monitor meter data, Relay Word bits, and output contacts status during testing.

Use the PC interface to remotely retrieve breaker wear, voltage sag/swell/interruption reports, and other power system data.

Metering and Monitoring

Table 1 Metering Capabilities

Quantities	Description
Currents (local) $I_{A, B, C, \text{pol}}, I_1, 3I_2, 3I_0$	Individual phase, polarizing, and sequence currents for local relay terminal.
Currents (remote and difference) $I_{A, B, C}, I_1, 3I_2, 3I_0$	Individual phase and sequence currents for remote relay terminal and difference currents.
Voltages $V_{A, B, C, S}, V_0, V_1, V_2$	Individual phase voltages for wye-connected PTs, and positive-, negative-, and zero-sequence voltages.
Power $MW_{A, B, C, 3P}, MVAR_{A, B, C, 3P}$	Single-phase and three-phase MW and MVAR available for wye-connected PTs.
Energy $MWh_{A, B, C, 3P}, MVARh_{A, B, C, 3P}$	Single-phase and three-phase MW and MVARh available for wye-connected PTs.
Power Factor $PF_{A, B, C, 3P}$	Single-phase and three-phase power factor; leading or lagging.

Advanced Metering Capabilities

The SEL-311L provides extensive metering capabilities, as shown in *Table 1*. Metering accuracies are provided in the *Specifications on page 1.23*. Metering information is displayed on the relay front panel or is available via communications over the serial port.

Use the current differential meter to verify line charging current. Compare local and remote currents to detect CT connection errors or CT ratio setting errors at any terminal.

If voltages are supplied to the relay, power and energy quantities are also available.

Event Reporting and SER

Event Reports and Sequential Events Recorder (SER) simplify post-fault analysis and improve understanding of simple and complex protective scheme operations. They also aid in testing and troubleshooting relay settings and protection schemes.

Eleven 60-cycle, twenty-two 30-cycle, or forty-one 15-cycle oscillographic event reports provide 4 or 16 samples per cycle resolution for remote and differential phase currents, each local analog channel, system frequency, dc system voltage, contact I/O, and many relay elements. Use the local and remote current oscillography to completely reconstruct complex system disturbances, and check local and remote CT connections during commission testing from a single report (see *Figure 23*).

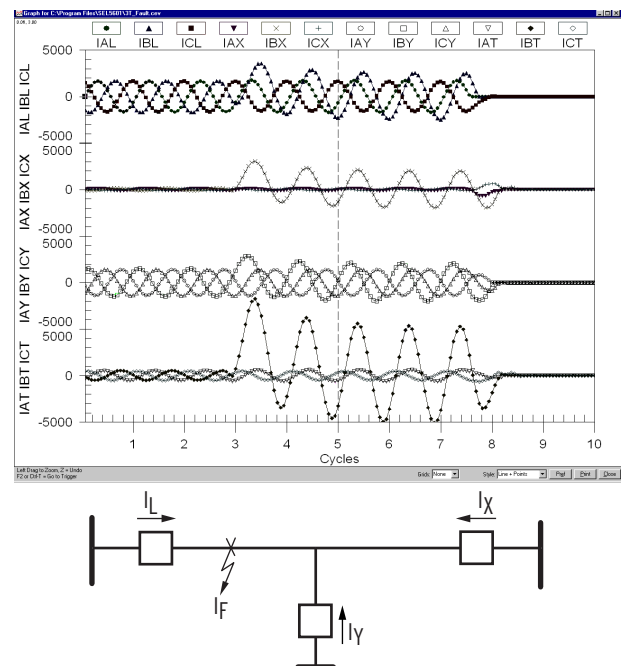
Figure 23 Three-Terminal Oscillograph From Any Terminal

The SEL-311L SER records the last 512 event entries, which may include contact inputs, internal relay conditions, relay setting changes, and relay power-up.

The IRIG-B time-code input synchronizes the SEL-311L Relay SER time stamps to within ± 5 ms of the time-source input. A convenient source for this time code is the SEL-2032, SEL-2030, or SEL-2020 Communications Processor (via Serial Port 2 on the SEL-311L). Line current differential protection does not rely on IRIG-B time synchronization, nor on any other external source of time synchronization.

To simplify event analysis following an operation, relay settings are appended to the bottom of each event report.

Flexible Event Analysis

Examine line currents from two or three line ends in the same event report. Use the SEL-5601-2 SYNCHROWAVE® Event Software to help visualize power system disturbances.

Event Summary

Each time the relay generates a standard event report, it also generates a corresponding Event Summary (see *Figure 24*). This is a concise description of an event that includes the following information:

- Pre-fault and fault, local and remote phase, zero- and negative-sequence currents
- Status of each 87L channel
- Phase voltages
- Fault type at the time of the trip
- System frequency at the time of the trigger
- Recloser shot count at the time of the trigger
- Relay identification
- Event date and time
- Event type
- Fault location
- ALARM status
- Status of all MIRRORING BITS and 87L channels
- Trip and close time tags
- Breaker status (open/close)

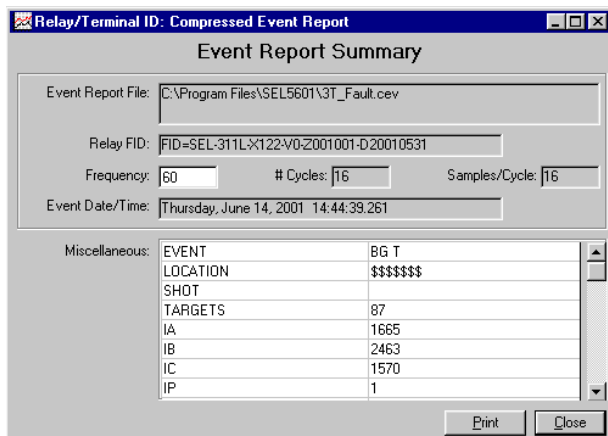

Figure 24 Example Event Report Summary

The relay automatically sends an Event Summary to all serial ports set as “AUTO” each time an event report is triggered.

The relay gives each Event Summary a unique identifier. This allows an automated event system, such as the SEL-5040, to acknowledge triggered events, and to retrieve the associated oscillographic report reliably.

Synchrophasor Measurements

Upgrade System Models

Send synchrophasor data by using SEL Fast Message protocol to SEL communications processors, or to SEL-5077 SYNCHROWAVE Server phasor data concentration software, or to an SEL-3306 Synchrophasor Processor. Data rates of as much as one message per second with an accuracy of ± 1 electrical degree provide for real-time visualization.

The SEL-5077 SYNCHROWAVE Server software and the SEL-3306 Synchrophasor Processor time correlate data from multiple SEL-311 relays and other phasor measurement and control units (PMcus). Then, the SEL-5077 sends the concentrated data to visualization tools, such as the SEL-5078-2 SYNCHROWAVE Central Visualization and Analysis Software, for use by utility operations.

Use SEL-2032 or SEL-2030 Communications Processors to collect synchrophasor data from multiple SEL-311 relays and incorporate the data into traditional SCADA and EMS systems. Traditional power system models are created based on measurements of voltages and power flows at different points on the system. The system state is then estimated based on a scan of these values and an iterative calculation. The state estimation includes an inherent error caused by measurement inaccuracies, time delays between measurements, and model simplifications. Synchrophasor measurements reduce error and change state estimation into state measurement. The time required for iterative calculation is minimized, and system state values can be directly displayed to system operators and engineers.

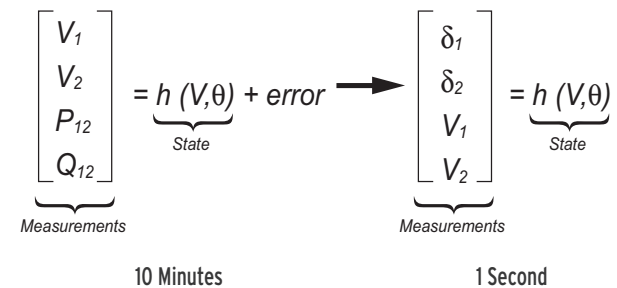

Figure 25 Synchrophasor Measurements Turn State Estimation Into State Measurement

Improve Situational Awareness

Provide improved information to system operators. Advanced synchrophasor-based tools provide a real-time view of system conditions. Use system trends, alarm points, and preprogrammed responses to help operators prevent a cascading system collapse and maximize system stability. Awareness of system trends provides operators with an understanding of future values based on measured data.

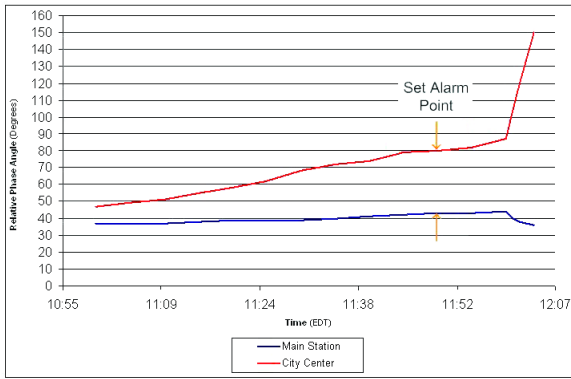

Figure 26 Visualization of Phase Angle Measurements Across a Power System

- Increase system loading while maintaining adequate stability margins.
- Improve operator response to system contingencies such as overload conditions, transmission outages, or generator shutdown.
- Advance system knowledge with correlated event reporting and real-time system visualization.
- Validate planning studies to improve system load balance and station optimization.

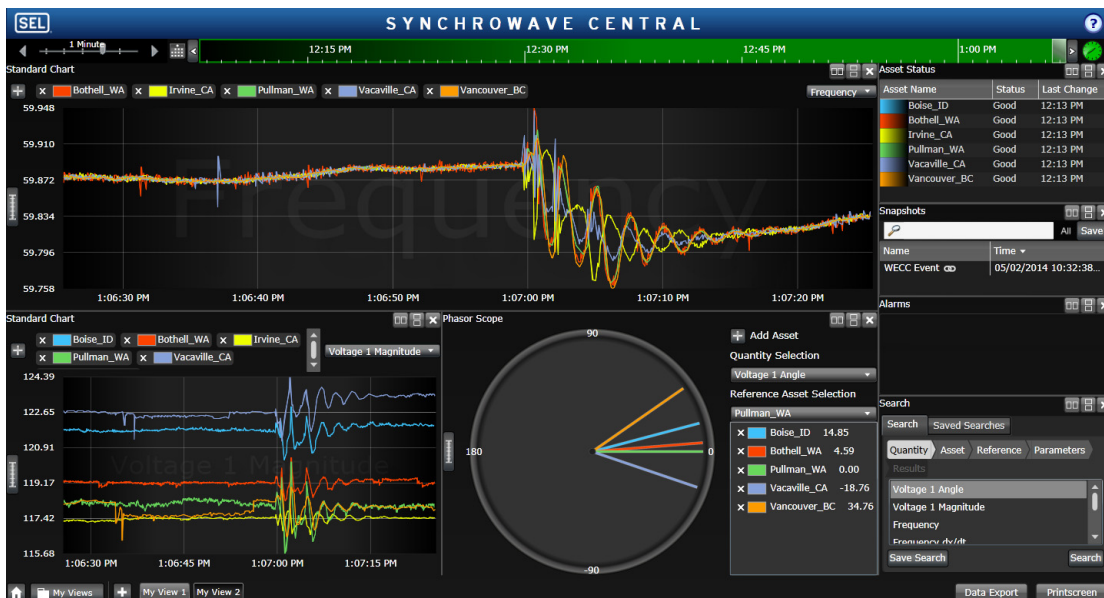

Figure 27 SYNCHROWAVE Central Real-Time Wide-Area Visualization Tool

IEC 61850 Communications (SEL-311L-1 and SEL-311L-7)

IEC 61850 Ethernet-based communications provide interoperability between intelligent devices within the substation. Logical nodes using IEC 61850 communications allow standardized interconnection of intelligent devices from different manufacturers for monitoring and control of the substation. Reduce wiring between various manufacturers' devices and simplify operating logic with SEL-311L relays equipped with IEC 61850. Eliminate system RTUs by streaming monitoring and control information from the intelligent devices directly to remote SCADA client devices.

The SEL-311L-1 or SEL-311L-7 can be ordered with embedded IEC 61850 communications operating on dual failover 100 Mbps Ethernet interfaces. Use IEC 61850 communications for relay monitoring and control functions, including:

- As many as 16 incoming GOOSE messages. The incoming GOOSE messages can be used to control as many as 32 control bits in the relay with <10 ms latency from device to device. These messages provide binary control inputs to the relay for high-speed control functions and monitoring.
- As many as eight outgoing GOOSE messages. Outgoing GOOSE messages can be configured for Boolean or analog data. Boolean data are provided with <10 ms latency from device to device. Use outgoing GOOSE messages for high-speed control and monitoring of external breakers, switches and other devices.
- IEC 61850 Data Server. SEL-311L relays equipped with embedded IEC 61850 communications provide data according to predefined logical node objects. As many as six simultaneous client associations are supported by each relay. Relevant Relay Word bits are available within the logical node data, so status of relay elements, inputs, outputs, or SELOGIC control equations can be monitored using the IEC 61850 data server provided in the relay.

Use the ACCELERATOR Architect[®] SEL-5032 Software to manage the logical node data for all IEC 61850 devices on the network. This Microsoft Windows-based software provides easy-to-use displays for identifying and binding IEC 61850 network data between logical nodes using IEC 61850-compliant CID (Configured IED Description) files. CID files are used by Architect to describe the data that will be provided by the IEC 61850 logical node within each relay.

Telnet, FTP, and Read-Only Web Server

Order the SEL-311L-1 or the SEL-311L-7 with Ethernet communications and use the built-in Telnet and FTP (File Transfer Protocol) that come standard with Ethernet to enhance relay communication sessions. Use Telnet to access relay settings, metering, and event reports remotely using the ASCII interface. Upload IEC 61850 CID files to the relay via the high-speed Ethernet port using FTP.

Enable the integrated read-only web server and browse the relay with any standard web browser to safely read settings, verify relay self-test status, inspect meter reports, read relay configuration, and more. The web server allows no control or modification actions, so users can be confident that an inadvertent button press will have no adverse effects.

Substation Battery Monitor for DC Quality Assurance

The SEL-311L measures and reports the substation battery voltage presented to its power supply terminals. The relay includes two programmable threshold comparators and associated logic for alarm and control. For example, if the battery charger fails and the measured dc voltage falls below a programmable threshold, operations personnel are then notified before the substation battery voltage falls to unacceptable levels. Monitor these thresholds with the SEL Communications Processor. Use the SEL Communications Processor to trigger messages, initiate telephone calls, or take other actions.

Automation

Flexible Control Logic and Integration Features

Use the SEL-311L control logic to:

- Replace traditional panel control switches.
- Replace traditional indicating panel lights.
- Replace traditional latching relays.
- Eliminate RTU-to-relay wiring.

Eliminate traditional panel control switches with 16 local control switches. Set, clear, or pulse local control switches with the front-panel pushbuttons and display.

The measured dc voltage is reported in the METER display via serial port communications, on the LCD, and in the event report. Use the event report data to see an oscillographic display of the battery voltage. You can see how the substation battery voltage drops during trip, close, and other control operations.

Breaker Monitor Feature Allows for Intelligent Breaker Maintenance Scheduling

Circuit breakers experience mechanical and electrical wear every time they operate. Effective scheduling of breaker maintenance takes into account the manufacturer's published data of contact wear versus interruption levels and operation count. The SEL-311L breaker monitor feature compares the breaker manufacturer's published data to the interrupted current.

Every time the breaker trips, the interrupted current is added to its previous value. When the result of this addition exceeds the threshold set by the breaker wear curve (*Figure 28*), the relay can alarm via serial port, output contact, or the front-panel display. With this information, breaker maintenance is scheduled in a timely, economical fashion.

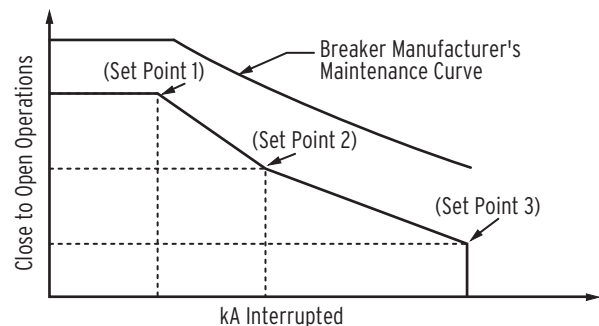

Figure 28 Breaker Contact Wear Curve and Settings

Program the local control switches into your control scheme via SELOGIC control equations. Use the local control switches to trip test, enable/disable reclosing, trip/close the breaker, etc.

Eliminate RTU-to-relay wiring with 16 remote control switches. Set, clear, or pulse remote control switches via serial port commands. Program the remote control switches into your control scheme via SELOGIC control equations. Use remote control switches for SCADA-type control operations: trip, close, settings group selection, etc.

Replace traditional latching relays for such functions as “remote control enable” with 16 latching control switches. Program latch set and latch reset conditions with SELOGIC control equations. Set or reset the latch control switches via optoisolated inputs, remote bits, local bits, or any programmable logic condition. The latch control switches retain their state when the relay loses power.

Replace traditional indicating panel lights with 16 programmable displays. Define custom messages (e.g., REMOTE BREAKER OPEN, REMOTE BREAKER CLOSED, RECLOSER ENABLED) to report power system or relay conditions on the LCD. Control which messages are displayed via SELOGIC control equations by using any logic point in the relay.

Serial Communications

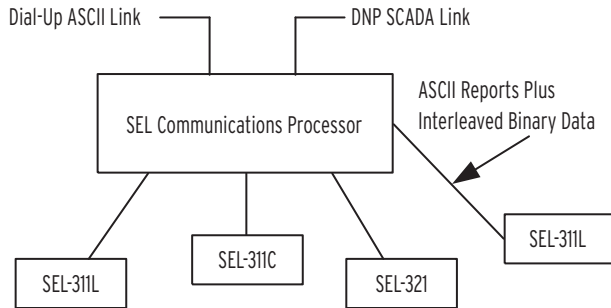

Figure 29 Example Communication System

Three EIA-232 serial ports and one isolated EIA-485 serial port each operate independently of the other serial ports.

- Full access to event history, relay status, and meter information from the serial ports.
- Settings and group switching have password control.
- DNP3 Level 2 protocol with point mapping (optional).
- Open communications protocols (see Table 2).

The relay does not require special communications software. ASCII terminals, printing terminals, or a computer supplied with terminal emulation and a serial communications port is all that is required. SEL manufactures a variety of standard cables for connecting this and other relays to a variety of external devices. Consult your SEL representative for more information on cable availability.

Table 2 Open Communications Protocols

Type	Description
Simple ASCII	Plain language commands for human and simple machine communications. Use for metering, setting, self-test status, event reporting, and other functions.
Compressed ASCII	Comma-delimited ASCII data reports. Allows external devices to obtain relay data in an appropriate format for direct import into spreadsheets and database programs. Data are checksum protected.
Extended Fast Meter, Fast Operate, and Fast SER	Binary protocol for machine-to-machine communications. Quickly updates SEL-2032/2030/2020, RTUs, and other substation devices with metering information, relay element, I/O status, time-tags, open and close commands, summary event reports, and Sequence of Events records. Data are checksum protected. Binary and ASCII protocols operate simultaneously over the same communications lines so control operator metering information is not lost while transferring an event report.
Distributed Port Switch Protocol	Enables multiple SEL devices to share a common communications bus (two-character address setting range is 01–99). Use this protocol for low-cost, port-switching applications.
DNP3 Level 2 Slave	Certified Distributed Network Protocol. Includes capability for settings-based DNP events, full-point remapping, individual scaling and deadband thresholds for analog inputs.
IEC 61850	Ethernet-based international standard for interoperability between intelligent devices in a substation.

Relay-to-Relay Digital Communications (MIRRORED BITS)

In addition to the differential channels, the SEL-311L includes MIRRORED BITS communications which can operate simultaneously on any two serial ports for three-

terminal operation. The SEL patented MIRRORED BITS technology provides bidirectional relay-to-relay digital communications (see Figure 30).

This bidirectional digital communication creates eight additional outputs (transmitted MIRRORING BITS) and eight additional inputs (received MIRRORING BITS) for each serial port operating in the MIRRORING BITS mode. These MIRRORING BITS can be used to transfer information between line terminals to enhance coordination and achieve faster tripping or to provide additional contact I/O with the SEL-2505. MIRRORING BITS also help reduce total pilot scheme operating time by eliminating the need to close output contacts and debounce contact inputs. Use the dual-port MIRRORING BITS capabilities for high-speed communications-assisted schemes applied to three-terminal transmission lines.

Advanced SELOGIC Control Equations

Advanced SELOGIC control equations put relay logic in the hands of the protection engineer. Assign the relay inputs to suit your application, logically combine selected relay elements for various control functions, and assign outputs to your logic functions.

Programming SELOGIC control equations consists of combining relay elements, inputs, and outputs with SELOGIC control equation operators. Any element in the Relay Word can be used in these equations.

The SELOGIC control equation operators include the following: OR, AND, invert, parentheses, and rising and falling edges of element state changes.

In addition to Boolean-type logic, 16 general-purpose SELOGIC control equation timers eliminate external timers for custom protection or control schemes. Each timer has independent time-delay pickup and dropout settings. Program each timer input with any desired element (e.g., time-qualify a voltage element). Assign the timer output to trip logic, reclose logic, or other control scheme logic.

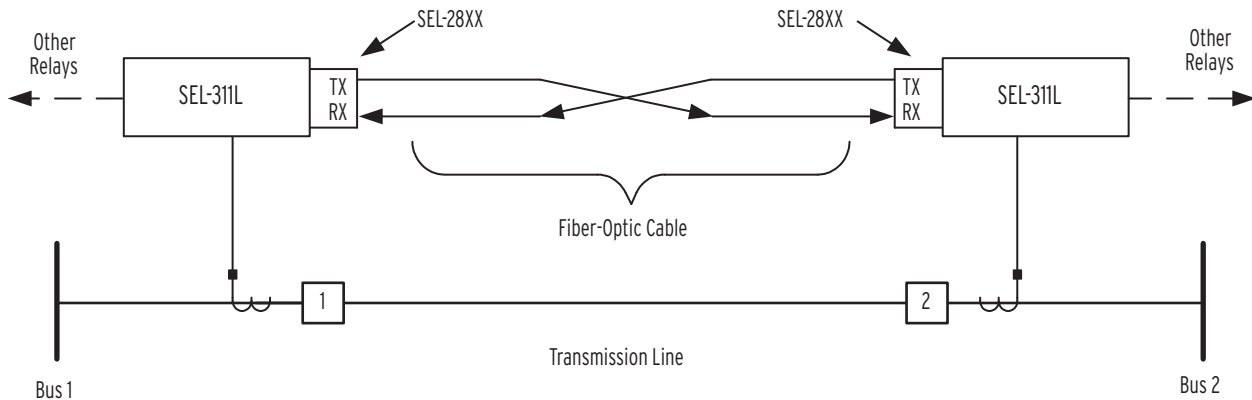

Figure 30 Integral MIRRORING BITS Communications Provides Secure Protection, Monitoring, and Control

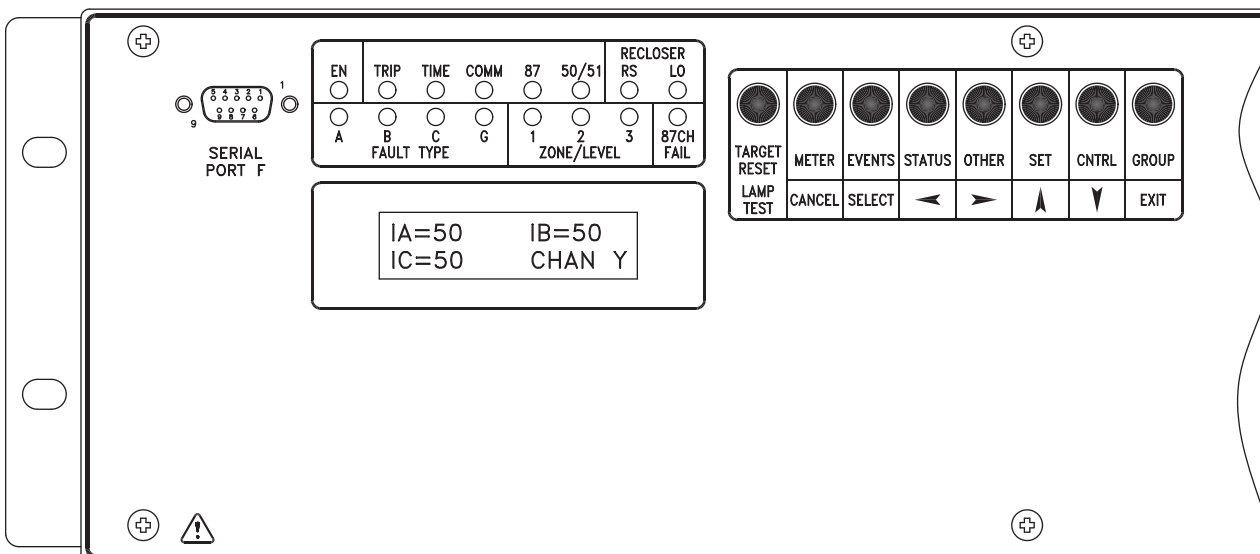

Figure 31 Status and Trip Target LEDs, Front-Panel Display, and Pushbuttons

Front-Panel User Interface

Status and Trip Target LEDs, Front-Panel Display, and Pushbuttons

Figure 31 shows a close-up view of the user interface portion of the SEL-311L front panel. It includes a two-line, 16-character LCD, 16 LED status and target indicators, and 8 pushbuttons for local communication. Table 3 explains the front-panel LEDs.

The LCD shows event, metering, setting, and relay self-test status information and allows relay settings changes without the need for a data terminal.

The LCD is controlled by the pushbuttons, automatic messages the relay generates, and user-programmed Display Points. The default display scrolls through any active, nonblank Display Points. If none are active, the relay scrolls through four two-line displays of the A-, B-, and C-phase local and remote currents in primary quantities. Each display remains for two seconds, before scrolling continues. Any message generated by the relay due to an alarm condition takes precedence over the normal default display. The EXIT pushbutton returns the display to the default display, if some other front-panel function is being performed.

Error messages such as self-test failures are displayed on the LCD in place of the default display when they occur.

Table 3 Description of Target LEDs

Target LED	Function
EN	Relay powered properly and self-tests okay
TRIP	Indication that a trip occurred
TIME	Time-delayed trip
COMM	Communications-assisted trip
87	Line current differential trip
50/51	Instantaneous and time-overcurrent trip
RECLOSER	
RS	Ready for reclose cycle
LO	Control in lockout state
FAULT TYPE	
A, B, C	Phase(s) involved in fault
G	Ground involved in fault
ZONE/LEVEL	
1-3	Trip by Zone 1–3 distance elements and/or Level 1–3 overcurrent elements
87CH FAIL	Failure of active differential channel

Contact Inputs and Outputs

The SEL-311L includes six high-speed/high-interrupting outputs as well as eight standard duty output contacts and six optoisolated inputs. Assign the contact inputs for control functions, monitoring logic, and general indication. Except for a dedicated alarm output, each contact output is programmable using SELOGIC control equations.

Wiring Diagram

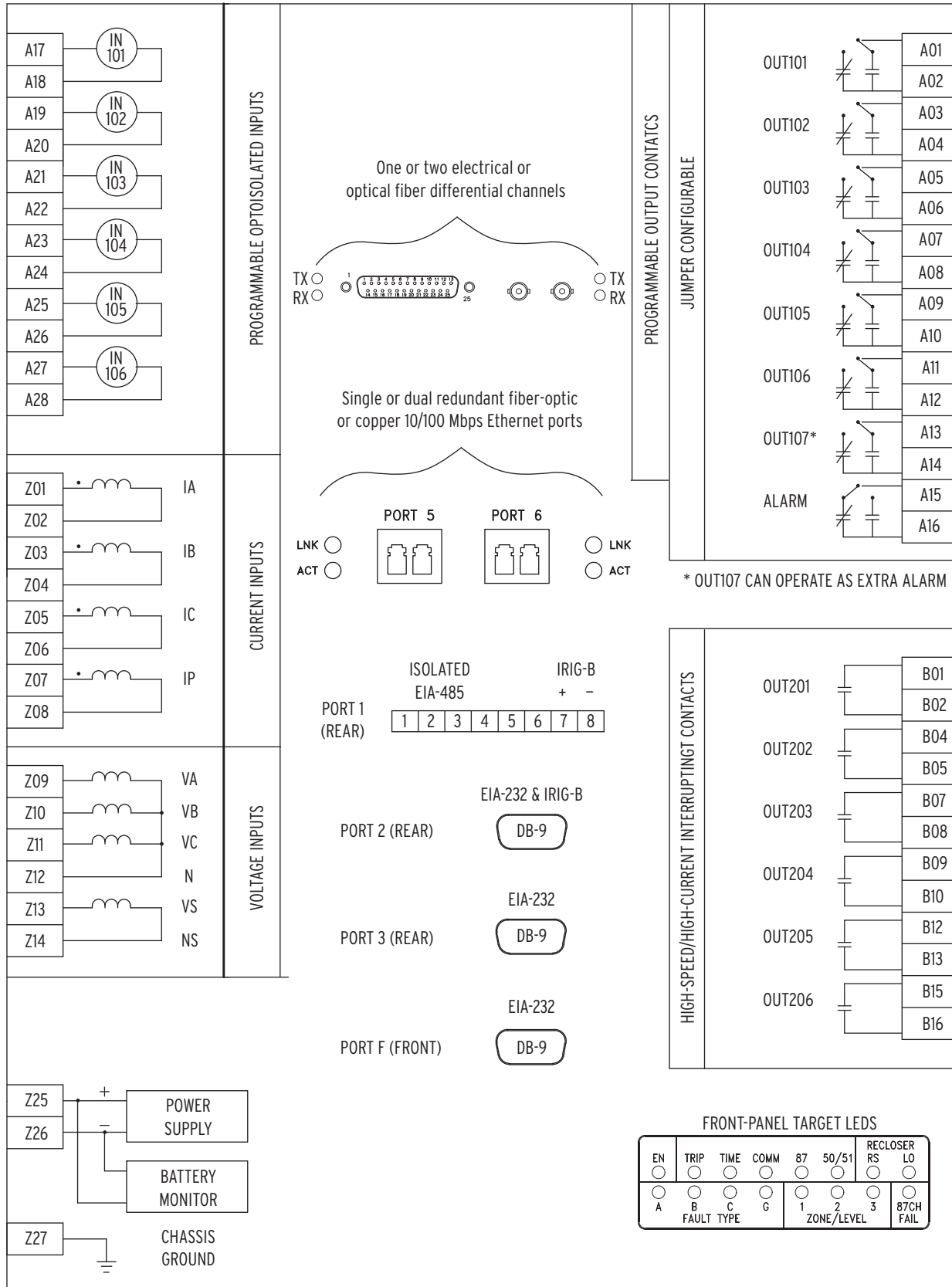
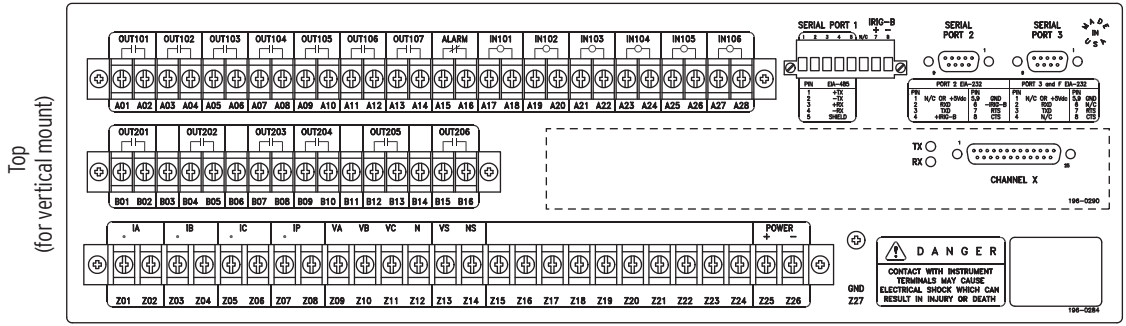
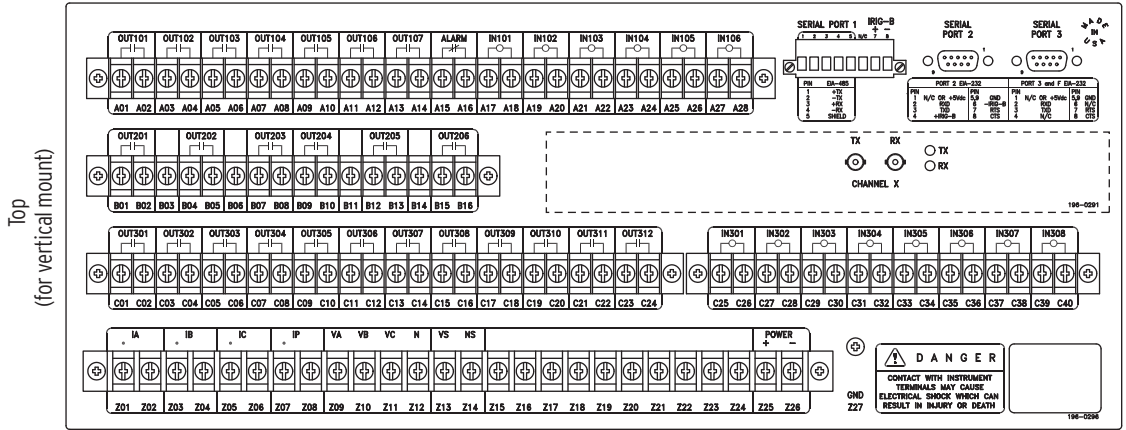

Figure 32 SEL-311L Inputs, Outputs, and Communications Ports



3U Rear Panel-Differential Channel Option With DB-25 Connector Outlined

13438b



4U Rear Panel-Differential Channel Option With Fiber-Optic Connectors

13679a

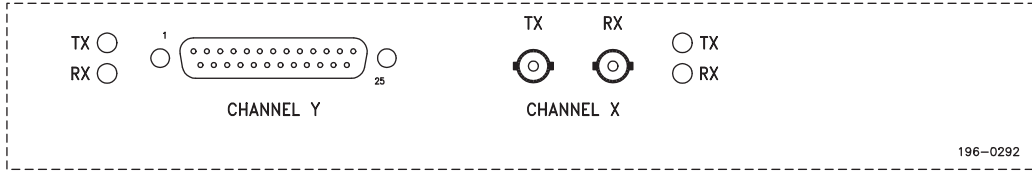

Differential Channel Option With DB-25 and Fiber-Optic Connectors

196-0292



Differential Channel Option With 2 DB-25 Connectors

196-0294

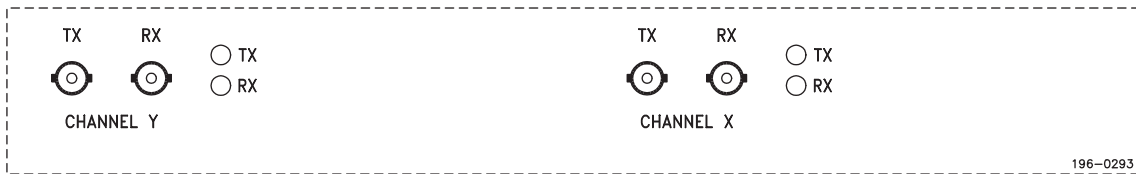

Differential Channel Option With 2 Fiber-Optic Connectors

196-0293

Figure 34 SEL-311L Rear-Panel Diagrams Showing Differential Channel Options

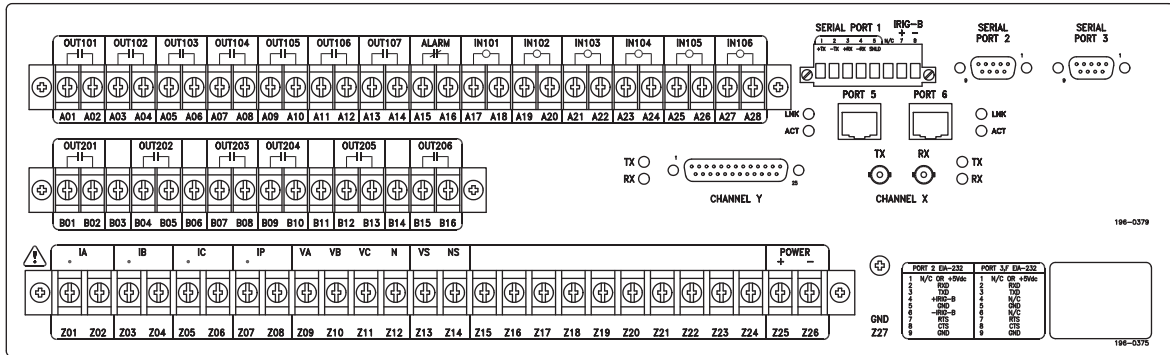

13976a

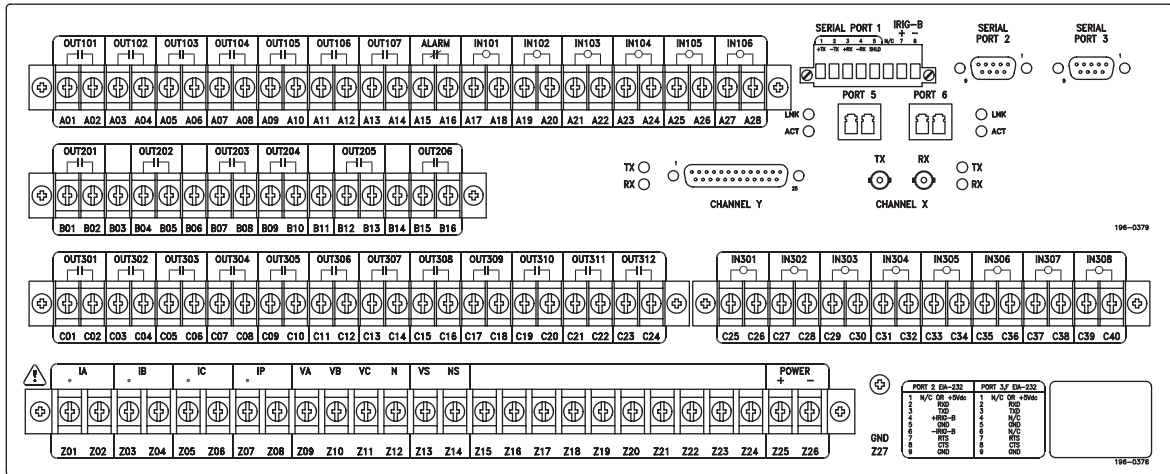

13979a

Figure 35 Typical Rear-Panel Diagrams Showing Dual 10/100BASE-T and Dual 100BASE-FX Ethernet

Relay Dimensions

PANEL-MOUNT CHASSIS

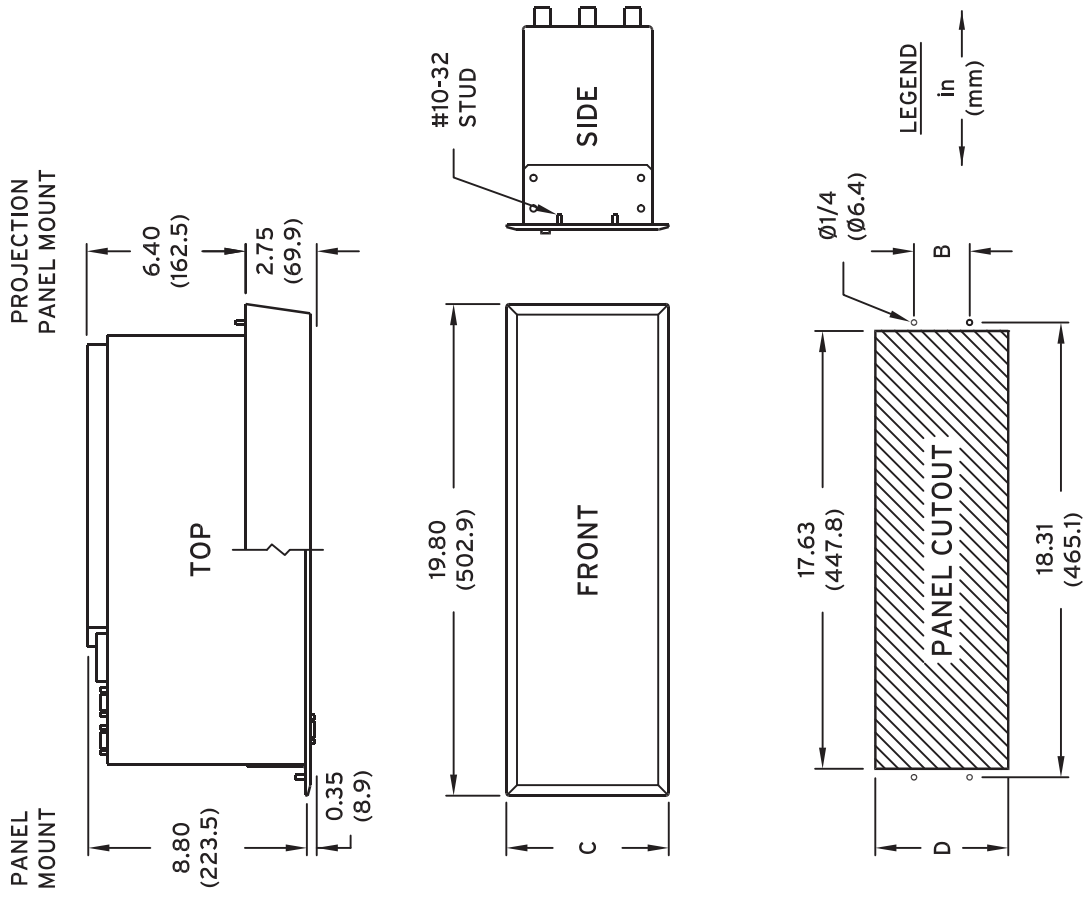

RACK-MOUNT CHASSIS

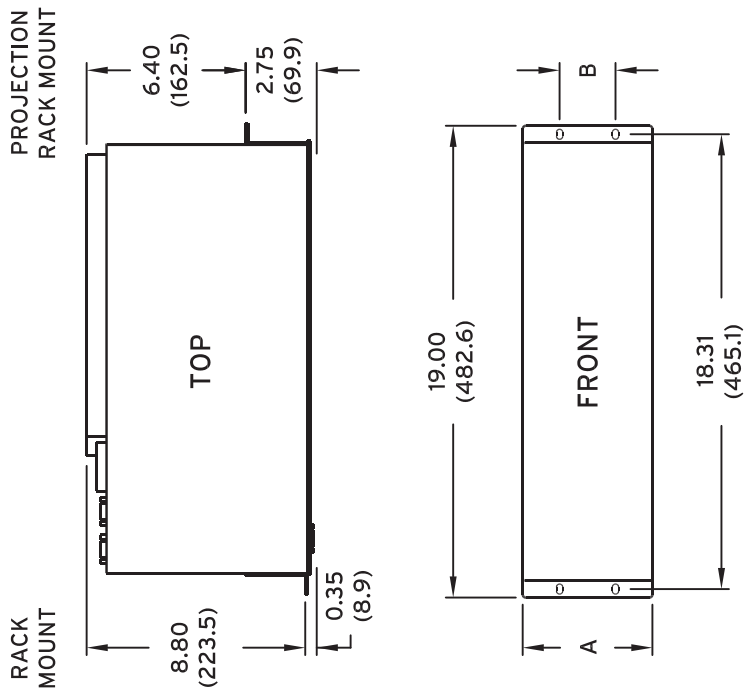

DIMENSION	ONE I/O BOARD (3U)	TWO I/O BOARD (4U)
A	5.22 (132.6)	6.97 (177.0)
B	2.25 (57.2)	4.00 (101.6)
C	6.65 (168.9)	8.40 (213.4)
D	5.35 (135.9)	7.10 (180.3)

For projection rack mounting, brackets must be reversed.

Figure 36 SEL-311L Dimensions for Rack- and Panel-Mount Models

i9057a

Specifications

Compliance

Designed and manufactured under an ISO 9001 certified quality management system
UL Listed to U.S. and Canadian safety standards (File E212775; NRGU, NRGU7)

CE Mark
UKCA Mark
RCM Mark
Class 1 Laser Product

Note: This equipment has been tested and found to comply with the limits for a Class A digital device, pursuant to part 15 of the FCC Rules. These limits are designed to provide reasonable protection against harmful interference when the equipment is operated in a commercial environment. This equipment generates, uses, and can radiate radio frequency energy and, if not installed and used in accordance with the instruction manual, may cause harmful interference to radio communications. Operation of this equipment in a residential area is likely to cause harmful interference in which case the user will be required to correct the interference at his own expense.

General

Terminal Connections

Rear Screw-Terminal Tightening Torque:

Minimum:	9 in-lb (1.1 Nm)
Maximum:	12 in-lb (1.3 Nm)

Terminals or stranded copper wire. Ring terminals are recommended. Minimum temperature rating of 105°C.

AC Current Input

Nominal:	5 A
Continuous:	15 A, linear to 100 A symmetrical.
Thermal Rating:	500 A for 1 second. 1250 A for 1 cycle.
Measurement Range:	0.5–96 A (DC offset for 1.5 cycles @ X/R = 10)
Burden:	0.27 VA at 5 A 2.51 VA at 15 A
Nominal:	1 A
Continuous:	3 A, linear to 20 A symmetrical.
Thermal Rating:	100 A for 1 second. 250 A for 1 cycle.
Measurement Range:	0.1–19.2 A (DC offset for 1.5 cycles @ X/R = 10)
Burden:	0.13 VA at 1 A 1.31 VA at 3 A

AC Voltage Inputs

Nominal:	67 V_{L-N} three-phase four-wire connection.
Continuous:	150 V_{L-N} (connect any voltage up to 150 Vac).
Measurement Range:	365 Vac for 10 seconds.
Burden:	0.13 VA at 67 V 0.45 VA at 120 V

Power Supply

Input Voltage	
Rated:	125/250 Vdc or Vac
Range:	85–350 Vdc or 85–264 Vac
Rated:	48/125 Vdc or 125 Vac

Range:	38–200 Vdc or 85–140 Vac
Rated:	24/48 Vdc
Range:	18–60 Vdc polarity-dependent
Power Consumption:	<25 W

Control Outputs

Standard	
Make:	30 A
Carry:	6 A continuous carry at 70°C 4 A continuous carry at 85°C
I s Rating:	50 A
MOV Protection (maximum voltage):	270 Vac, 360 Vdc, 40 J
Pickup/Dropout Time:	<5 ms
Breaking Capacity (10,000 operations):	
48 Vdc	0.50 A L/R = 40 ms
125 Vdc	0.30 A L/R = 40 ms
250 Vdc	0.20 A L/R = 40 ms

Cyclic Capacity (2.5 cycles/second):

48 Vdc	0.50 A	L/R = 40 ms
125 Vdc	0.30 A	L/R = 40 ms
250 Vdc	0.20 A	L/R = 40 ms

Hybrid (High Current Interrupting)

Make:	30 A	
Carry:	6 A continuous carry at 70°C 4 A continuous carry at 85°C	
I s Rating:	50 A	
MOV Protection (maximum voltage):	330 Vdc, 130 J	
Pickup/Dropout Time:	<5 ms	
Breaking Capacity (10,000 operations):		
48 Vdc	10.0 A	L/R = 40 ms
125 Vdc	10.0 A	L/R = 40 ms
250 Vdc	10.0 A	L/R = 20 ms

Cyclic Capacity (4 interruptions/second, followed by 2 minutes idle for thermal dissipation):

48 Vdc	10.0 A	L/R = 40 ms
125 Vdc	10.0 A	L/R = 40 ms
250 Vdc	10.0 A	L/R = 20 ms

Note: Make per IEEE C37.90-1989; Breaking and Cyclic Capacity per IEC 60255-23:1994.

Fast Hybrid (High Current Interrupting)

Make:	30 A	
Carry:	6 A continuous carry at 70°C 4 A continuous carry at 85°C	
I s Rating:	50 A	
MOV Protection (maximum voltage):	330 Vdc, 130 J	
Pickup/Dropout Time:	<10 μ s; <8 ms, typical	
Breaking Capacity (10,000 operations):		
48 Vdc	10.0 A	L/R = 40 ms
125 Vdc	10.0 A	L/R = 40 ms
250 Vdc	10.0 A	L/R = 20 ms

Cyclic Capacity (4 interruptions/second, followed by 2 minutes idle for thermal dissipation):

48 Vdc	10.0 A	L/R = 40 ms
125 Vdc	10.0 A	L/R = 40 ms
250 Vdc	10.0 A	L/R = 20 ms

Note: Make per IEEE C37.90-1989; Breaking and Cyclic Capacity per IEC 60255-23:1994.

Optoisolated Inputs

250 Vdc:	Pickup 200–300 Vdc; dropout 150 Vdc
220 Vdc:	Pickup 176–264 Vdc; dropout 132 Vdc
125 Vdc:	Pickup 105–150 Vdc; dropout 75 Vdc
110 Vdc:	Pickup 88–132 Vdc; dropout 66 Vdc
48 Vdc:	Pickup 38.4–60 Vdc; dropout 28.8 Vdc
24 Vdc:	Pickup 15–30 Vdc

Note: 24, 48, 125, 220, and 250 Vdc optoisolated inputs draw approximately 5 mA of current; 110 Vdc inputs draw approximately 8 mA of current. All current ratings are at nominal input voltages.

Frequency and Rotation

System Frequency:	50 or 60 Hz
Phase Rotation:	ABC or ACB
Frequency Tracking:	40.1–65 Hz

Serial Communications Ports

EIA-232:	1 Front, 2 Rear
EIA-485:	1 Rear, 2100 Vdc isolation
Baud Rate:	300–38400 (Port 1 Baud Rate 300–19200)

Ethernet Communications Ports (SEL-311L-1 and SEL-311L-7)

Application Protocols

FTP to Card:	1 server session (supports IEC 61850 CID files)
Telnet to Card:	1 server session (supports SEL ASCII)
Telnet to Host:	1 server session (supports SEL ASCII, SEL Compressed ASCII, Fast Meter and Fast Operate)
IEC 61850:	6 MMS sessions 16 incoming GOOSE messages 8 outgoing GOOSE messages
Web Server:	3 simultaneous read-only server sessions to host

Protocol Stacks

TCP/IP
OSI

Physical Layer Options (PORT 5 and PORT 6)

10/100BASE-T:	10/100 Mbps, RJ45 connector
100BASE-FX:	100 Mbps, LC connector

Indicators (PORT 5 and PORT 6)

Link:	Green LED is on when the link is operational.
Activity:	Red LED blinks when there is transmit or receive activity.

Differential Communications Ports

Fiber Optics—ST Connector

1550 nm Single Mode:	
Tx Power:	–18 dBm
Rx Min. Sensitivity:	–58 dBm

Rx Max. Sensitivity:	0 dBm
System Gain:	40 dB
Distance Limitations:	120 km

1300 nm Multimode or Single Mode:

Tx Power:	–18 dBm
Rx Min. Sensitivity:	–58 dBm
Rx Max. Sensitivity:	0 dBm
System Gain:	40 dB
Distance Limitations:	x km
where:	$x = 30$ for multimode $x = 80$ for single mode

1300 nm Single Mode (IEEE C37.94-Compatible Modulated):

Tx Power:	–24 dBm
Rx Min. Sensitivity:	–37.8 dBm
Rx Max. Sensitivity:	0 dBm
System Gain:	13.8 dB
Distance Limitations:	15 km

850 nm Multimode, IEEE C37.94-Compatible:

Tx Power:	50 μ m: –23 dBm; 62.5 μ m: –19 dBm
Rx Min. Sensitivity:	50 μ m: –32 dBm; 62.5 μ m: –32 dBm
Rx Max. Sensitivity:	50 μ m: –11 dBm; 62.5 μ m: –11 dBm
System Gain:	50 μ m: 9 dB; 62.5 μ m: 13 dB
Distance Limitations:	2 km

Electrical

EIA-422:	56 or 64 Kbps synchronous; Isolated to 1500 Vac
CCITT G.703:	64 Kbps synchronous, codirectional

Time-Code Input

Relay accepts demodulated IRIG-B time-code input at Port 1 or 2. Relay time is synchronized to within ± 5 ms of time-source input.

Synchronization (specification is with respect to the accuracy of the time source)

Synchrophasor:	$\pm 10 \mu$ s
Other:	± 5 ms

Current differential protection does not require an external time source.

Dimensions

Refer to *Figure 36* for relay dimensions.

Operating Temperature

–40° to +85°C (–40° to +185°F)

Note: LCD contrast impaired for temperatures below –20°C

Weight

3U Rack Unit: 6.9 kilograms (15.2 pounds)

4U Rack Unit: 8.3 kilograms (18.3 pounds)

Type Tests

Electromagnetic Compatibility Emissions

	EN 55011: 1998 + A1:1999 + A2:2002 Canada ICES-001 (A) / NMB-001 (A)
Product Specific Emissions:	IEC 60255-25:2000

Electromagnetic Compatibility Immunity

Conducted RF Immunity:	IEC 60255-22-6:2001 Severity Level: 10 Vrms
Radiated Radio Frequency Immunity:	IEC 60255-22-3:2007 Severity Level: 10 V/m IEC 61000-4-3:2010 Severity Level: 10 V/m
Radiated Digital Radio Telephone RF Immunity:	ENV 50204:1995 Severity Level: 10 V/m at 900 MHz and 1.89 GHz
Electrostatic Discharge Immunity:	IEC 60255-22-2:2008 Severity Level: 2, 4, 6, 8 kV contact; 2, 4, 8, 15 kV air IEEE C37.90.3-2001 Severity Level: 2, 4, and 8 kV contact; 4, 8, and 15 kV air
Fast Transient/Burst Immunity:	IEC 60255-22-4:2008 Severity Level: 4 kV, 5 kHz on power supply, 2 kV, 5 kHz on I/O, signal, data, and control lines IEC 61000-4-4:2011 Severity Level: 4 (4 kV on power supply), 3 (2 kV on inputs and outputs)
Power Supply Immunity:	IEC 60255-11:2008
Radiated Radio Frequency Immunity:	IEEE C37.90.2-2004 Severity Level: 35 V/m
Surge Withstand Capability Immunity:	IEC 60255-22-1:2007 Severity Level: 2.5 kV peak common mode, 1.0 kV peak differential mode IEEE C37.90.1-2002 Severity Level: 2.5 kV oscillatory, 4 kV fast transient waveform

Environmental

Cold:	IEC 60068-2-1:2007 Severity Level: 16 hours at -40°C
Dry Heat:	IEC 60068-2-2:2007 Severity Level: 16 hours at +85°C
Damp Heat, Cyclic:	IEC 60068-2-30:2005 Severity Level: 25°C to 55°C, 6 cycles, Relative Humidity: 95%
Vibration:	IEC 60255-21-3:1993 Severity Level: Class 2 (Quake Response) IEC 60255-21-1:1988 Severity Level: Class 1–Endurance, Class 2–Response IEC 60255-21-2:1988 Severity Level: Class 1–Shock withstand, Bump, and Class 2–Shock Response

Safety

Product Safety:	EN 50263:1999
IP Code:	IEC 60529:2001 + CRGD:2003 Severity Level: IP30 for Category 2 equipment
Insulation Coordination:	IEC 60255-5:2000 Severity Level: 5 kV Impulse on DI, DO, AI, and Power Supply; 2.2 kV on IRIG-B, EIA-485 and Ethernet. 2.5 kVac Dielectric on DI, DO, and AI; 3.1 kVdc on Power Supply; 2.2 kVdc on EIA-485; 1.5 kVac on Ethernet. Type tested for 1 minute.

Laser Safety:	IEC 60825-1:2007 Product Class: Class 1 21 CFR 1040.10 Product Class: Class 1 ANSI Z136.1-2007 Product Class: Class 1
Product Safety:	IEC 60255-6:1988

Processing Specifications

AC Voltage and Current Inputs

16 samples per power system cycle, 3 dB low-pass filter cut-off frequency of 560 Hz.

Digital Filtering

One-cycle full cosine after low-pass analog filtering. Net filtering (analog plus digital) rejects dc and all harmonics greater than the fundamental.

Current Differential Processing

16 times per power system cycle for line current differential protection and tripping logic.

Backup Protection and Control Processing

4 times per power system cycle

Relay Elements

Line Current Differential (87L) Elements

87L Enable Levels (Difference or Total Current)

Phase Setting Range:	OFF, 1.00 to 10.00 A, 0.01 A steps
Negative-Sequence Setting Range:	OFF, 0.50 to 5.00 A, 0.01 A steps
Zero-Sequence Setting Range:	OFF, 0.50 to 5.00 A, 0.01 A steps
Accuracy:	±3% ±0.01 I _{NOM}

Restraint Characteristics

Outer Radius

Radius Range: 2 to 8 in steps of 0.1 (unitless).

Angle Range: 90–270° in steps of 1°

Accuracy: ±5% of radius setting
±3° of angle setting

Operate Time (for bolted fault): See operate time curves in *Section 3* of the Instruction Manual.

Note: Refer to *Current Differential Elements* in *Section 3* of the Instruction Manual for the definition of terms and terminology listed above.

Difference Current Alarm Setting

Setting Range:	OFF, 0.5 to 10.0 A, 0.1 A steps
Accuracy:	±3% of ±0.01 I _{NOM}

Substation Battery Voltage Monitor Specifications

Pickup Range:	20–300 Vdc, 1 Vdc steps
Pickup Accuracy:	±2% ±2 Vdc of setting

Timer Specifications

Reclosing Relay Pickup:	0.00–999,999.00 cycles, 0.25-cycle steps (reclosing relay and some programmable timers)
Other Timers:	0.00–16,000.00 cycles, 0.25-cycle steps (some programmable and other various timers)
Pickup/Dropout Accuracy for All Timers:	±0.25 cycle and ±0.1% of setting

Mho Phase Distance Elements

Zones 1–4 Impedance Reach

Setting Range: OFF, 0.05 to 64.00 Ω secondary,
0.01 Ω steps (5 A nominal)
OFF, 0.25 to 320.00 Ω secondary, 0.01 Ω
steps (1 A nominal)

Note: Minimum sensitivity is controlled by the pickup of the supervising phase-to-phase overcurrent elements for each zone, load encroachment, OSB, and supervisory directional logic.

Accuracy: $\pm 5\%$ of setting at line angle
for $30 \leq \text{SIR} \leq 60$
 $\pm 3\%$ of setting at line angle
for $\text{SIR} < 30$

Transient Overreach: $< 5\%$ of setting plus steady-state
accuracy

Zones 1–4 Phase-to-Phase Current Fault Detectors (FD)

Setting Range: 0.5–170.0 A_{p-p} secondary,
0.01 A steps (5 A nominal)
0.1–34.0 A_{p-p} secondary,
0.01 A steps (1 A nominal)

Accuracy: ± 0.05 A and $\pm 3\%$ of setting
(5 A nominal)
 ± 0.01 A and $\pm 3\%$ of setting
(1 A nominal)

Transient Overreach: $< 5\%$ of pickup

Max. Operating Time: See pickup and reset time curves in
Section 4 of the Instruction Manual.

Mho and Quadrilateral Ground Distance Elements

Zones 1–4 Impedance Reach

Mho Element Reach: OFF, 0.05 to 64.00 Ω secondary,
0.01 Ω steps (5 A nominal)
OFF, 0.25 to 320.00 Ω secondary, 0.01 Ω
steps (1 A nominal)

Quadrilateral Reactance Reach: OFF, 0.05 to 64.00 Ω secondary,
0.01 Ω steps (5 A nominal)
OFF, 0.25 to 320.00 Ω secondary, 0.01 Ω
steps (1 A nominal)

Quadrilateral Resistance Reach: OFF, 0.05 to 50.00 Ω secondary,
0.01 Ω steps (5 A nominal)
OFF, 0.25 to 250.00 Ω secondary, 0.01 Ω
steps (1 A nominal)

Note: Minimum sensitivity is controlled by the pickup of the supervising phase and residual overcurrent elements for each zone, and supervisory directional logic.

Accuracy: $\pm 5\%$ of setting at line angle
for $30 \leq \text{SIR} \leq 60$
 $\pm 3\%$ of setting at line angle
for $\text{SIR} < 30$

Transient Overreach: $< 5\%$ of setting plus steady-state
accuracy

Zones 1–4 Phase and Residual Current Fault Detectors (FD)

Setting Range: 0.5–100.0 A secondary,
0.01 A steps (5 A nominal)
0.1–20.0 A secondary,
0.01 A steps (1 A nominal)

Accuracy: ± 0.05 A and $\pm 3\%$ of setting
(5 A nominal)
 ± 0.01 A and $\pm 3\%$ of setting
(1 A nominal)

Transient Overreach: $< 5\%$ of pickup

Max. Operating Time: See pickup and reset time curves in
Section 4 of the Instruction Manual.

Undervoltage and Overvoltage Elements

Pickup Range: OFF, 0.00–150.00 V, 0.01 V steps
(various elements)
OFF, 0.00–260.00 V, 0.01 V steps
(phase-to-phase elements)

Steady-State Pickup Accuracy: ± 1 V and $\pm 5\%$ of setting

Transient Overreach: $< 5\%$ of pickup

Instantaneous/Definite-Time Overcurrent Elements

Pickup Range: OFF, 0.25–100.00 A, 0.01 A steps
(5 A nominal)
OFF, 0.05–20.00 A, 0.01 A steps
(1 A nominal)

Steady-State Pickup Accuracy: ± 0.05 A and $\pm 3\%$ of setting
(5 A nominal)
 ± 0.01 A and $\pm 3\%$ of setting
(1 A nominal)

Transient Overreach: $< 5\%$ of pickup

Time Delay: 0.00–16,000.00 cycles, 0.25-cycle steps

Timer Accuracy: ± 0.25 cycle and $\pm 0.1\%$ of setting

Max. Operating Time: See pickup and reset time curves in
Section 4 of the Instruction Manual.

Time-Overcurrent Elements

Pickup Range: OFF, 0.25–16.00 A, 0.01 A steps
(5 A nominal)
OFF, 0.05–3.20 A, 0.01 A steps
(1 A nominal)

Steady-State Pickup Accuracy: ± 0.05 A and $\pm 3\%$ of setting
(5 A nominal)
 ± 0.01 A and $\pm 3\%$ of setting
(1 A nominal)

Time Dial Range: 0.50–15.00, 0.01 steps (US)
0.05–1.00, 0.01 steps (IEC)

Curve Timing Accuracy: ± 1.50 cycles and $\pm 4\%$ of curve time for
current between 2 and 30 multiples of
pickup.

Synchronism-Check Elements

Slip Frequency Pickup Range: 0.005–0.500 Hz, 0.001 Hz steps

Slip Frequency Pickup Accuracy: ± 0.003 Hz

Phase Angle Range: $0-80^\circ$, 1° steps

Phase Angle Accuracy: $\pm 4^\circ$

Definite-Time Overfrequency or Underfrequency (81) Elements

Pickup Range: 41.00–65.00 Hz, 0.01 Hz steps

Pickup Time: 32 ms at 60 Hz (max)

Time Delays: 2.00–16,000.00 cycles, 0.25-cycle steps

Maximum Definite-Time Delay Accuracy: ± 0.25 cycles, $\pm 1\%$ of setting at 60 Hz

Steady-State plus Transient Overshoot: ± 0.01 Hz

Supervisory 27: 20.0–150.0 V, $\pm 5\%$, ± 0.1 V

Metering Accuracy

Voltages

$V_A, V_B, V_C, V_S,$ $V_1, V_2, 3V_0:$	$\pm 2\%$ (33.5–150 V)
--------------------------------------------	------------------------

Currents

I_A, I_B, I_C, I_P (Local):	$\pm 1\%$ (0.5 to 100.0 A) (5 A nominal) $\pm 1\%$ (0.1 to 20.0 A) (1 A nominal)
$I_1, 3 I_0, 3I_2$ (Local):	$\pm 3\%$ (0.25 to 100.0 A) (5 A nominal) $\pm 3\%$ (0.05 to 20.0 A) (1 A nominal)
$I_A, I_B, I_C, 3I_2, 3I_0, I_1$ (Remote):	$\pm 3\%$ (0.25 to 100.0 A) (5 A nominal) $\pm 3\%$ (0.05 to 20.0 A) (1 A nominal)
$I_A, I_B, I_C, 3I_2, 3I_0, I_1$ (Total):	$\pm 3\%$ (0.25 to 100.0 A) (5 A nominal) $\pm 3\%$ (0.05 to 20.0 A) (1 A nominal)

Phase Angle Accuracy: $\pm 1^\circ$

MW/MVAR: $\pm 3\%$

Synchrophasor Accuracy

Note: Specification is with respect to **MET PM** command and SEL Fast Message Synchrophasor Protocol.

Voltages:	33.5–150 V; 45–65 Hz
Magnitudes:	$\pm 2\%$
Angles:	$\pm 1.0^\circ$
Currents:	0.50–1.25 A; 45–65 Hz (5 A nominal) 0.10–0.25 A; 45–65 Hz (1 A nominal)
Magnitudes:	$\pm 4\%$
Angles:	$\pm 1.5^\circ$ @ 25°C $\pm 2.0^\circ$ over the full temperature range
Currents:	1.25–7.50 A; 45–65 Hz (5 A nominal) 0.25–2.50 A; 45–65 Hz (1 A nominal)
Magnitudes:	$\pm 2\%$
Angles:	$\pm 1.0^\circ$ @ 25°C $\pm 1.5^\circ$ over the full temperature range

Technical Support

We appreciate your interest in SEL products and services. If you have questions or comments, please contact us at:

Schweitzer Engineering Laboratories, Inc.
2350 NE Hopkins Court
Pullman, WA 99163-5603 U.S.A.
Tel: +1.509.338.3838
Fax: +1.509.332.7990
Internet: selinc.com/support
Email: info@selinc.com

© 2001-2022 by Schweitzer Engineering Laboratories, Inc. All rights reserved.

All brand or product names appearing in this document are the trademark or registered trademark of their respective holders. No SEL trademarks may be used without written permission. SEL products appearing in this document may be covered by U.S. and Foreign patents.

Schweitzer Engineering Laboratories, Inc. reserves all rights and benefits afforded under federal and international copyright and patent laws in its products, including without limitation software, firmware, and documentation.

The information in this document is provided for informational use only and is subject to change without notice. Schweitzer Engineering Laboratories, Inc. has approved only the English language document.

This product is covered by the standard SEL 10-year warranty. For warranty details, visit selinc.com or contact your customer service representative.

SCHWEITZER ENGINEERING LABORATORIES, INC.

2350 NE Hopkins Court • Pullman, WA 99163-5603 U.S.A.
Tel: +1.509.332.1890 • Fax: +1.509.332.7990
selinc.com • info@selinc.com

