



# SEL-487B-1 Bus Differential and Breaker Failure Relay

## Busbar and Breaker Failure Protection, Automation, and Control System



### Key Features and Benefits

The SEL-487B-1 Bus Differential and Breaker Failure Relay provides bus current differential protection, circuit breaker failure protection, and backup overcurrent protection. The relay has 21 analog current inputs and three analog voltage inputs. For buses with no more than seven terminals, use one SEL-487B in a single-relay application. For buses with eight to ten terminals, use two SEL-487B relays. For buses with as many as 21 terminals, use three SEL-487B relays; each relay provides as many as six independent and adaptable zones of protection.

- ▶ **High-Speed Differential Protection.** Busbar differential protection operates in less than one cycle, which increases system stability margins and reduces equipment damage.
- ▶ **Six Differential Zones.** Flexible zone selection and six differential zones provide protection for multiple busbar applications.
- ▶ **Failed CT Detection.** The SEL-487B reliably indicates open and shorted CTs for alarming and/or blocking.
- ▶ **CT Ratio Mismatch.** Differential protection accommodates as high as 10:1 CT ratio mismatch without auxiliary CTs.
- ▶ **External Fault Security.** External fault detection logic secures differential protection for external faults with minimal CT requirements.
- ▶ **Overcurrent Elements.** Instantaneous and inverse time-overcurrent elements can provide backup protection for each terminal.
- ▶ **Voltage Elements.** Negative- and zero-sequence, over- and undervoltage elements can supervise the differential element.
- ▶ **Three Check Zones.** Three dedicated check zones in each relay can supervise complex bus differential schemes.
- ▶ **Breaker Failure.** Apply the relay to supply breaker failure protection for all supported breakers. Logic for breaker failure retrip and initiation of transfer tripping is included.

- ▶ **Ethernet Access.** The optional Ethernet card grants access to all relay functions. Use IEC 61850 Manufacturing Message Specification (MMS) or DNP3 protocol directly to interconnect with automation systems. You can also connect to DNP3 networks through a communications processor. Use File Transfer Protocol (FTP) for high-speed data collection.
- ▶ **Serial Data Communication.** The relay can communicate serial data through SEL ASCII, SEL Fast Message, SEL Fast Operate, MIRRORED BITS<sup>®</sup>, and DNP3 protocols.
- ▶ **Automation.** The enhanced automation features include programmable elements for local control, remote control, protection latching, and automation latching. Local metering on the large front-panel LCD eliminates the need for separate panel meters. Serial and Ethernet links efficiently transmit key information, including metering data, protection element and control I/O status, IEC 61850 GOOSE messages, Sequential Events Recorder (SER) reports, relay summary event reports, and time synchronization. Apply expanded SELOGIC<sup>®</sup> control equations with math and comparison functions in control applications. Incorporate as many as 1000 lines of automation logic to accelerate and improve control actions.
- ▶ **Battery Monitoring.** An alarm contact provides notification of substation battery voltage problems even if voltage is low only during trip or close operations.
- ▶ **Six Independent Settings Groups.** The relay includes group logic to adjust settings for different operating conditions, such as station maintenance, seasonal operations, emergency contingencies, loading, source changes, and adjacent relay settings changes. Select the active group settings by control input, command, or other programmable conditions.
- ▶ **Parallel Redundancy Protocol (PRP).** PRP provides seamless recovery from any single Ethernet network failure. The Ethernet network and all traffic are fully duplicated with both copies operating in parallel.
- ▶ **IEC 61850 Operating Modes.** The relay supports IEC 61850 standard operating modes such as Test, Blocked, On, and Off.
- ▶ **IEEE 1588, Precision Time Protocol (PTP).** PTP provides high-accuracy timing over an Ethernet network.
- ▶ **Digital Relay-to-Relay Communications.** MIRRORED BITS communications can monitor internal element conditions between bays within a station, or between stations, using SEL fiber-optic transceivers. Send digital, analog, and virtual terminal data over the same MIRRORED BITS channel.
- ▶ **Sequential Events Recorder (SER).** The SER records the last 1000 events, including setting changes, startups, and selectable logic elements.
- ▶ **Oscillography and Event Reporting.** The relay records voltages, currents, and internal logic points at a sampling rate as fast as 8 kHz. Offline phasor and harmonic-analysis features allow investigation of bay and system performance. Time-tag binary COMTRADE event reports with high-accuracy time stamping for accuracy better than 10  $\mu$ s.
- ▶ **Digitally Signed Upgrades.** The relay supports upgrading the relay firmware with a digitally signed upgrade file. The digitally signed portion of the upgrade file helps ensure firmware and device authenticity after it is sent over a serial or Ethernet connection.
- ▶ **Increased Security.** The relay divides control and settings into seven relay access levels; the relay has separate breaker, protection, automation, and output access levels, among others. Set unique passwords for each access level.
- ▶ **Rules-Based Settings Editor.** You can communicate with and set the relay by using an ASCII terminal or use QuickSet to configure the relay and analyze fault records with relay element response. Use as many as 200 aliases to rename any digital or analog quantity in the relay.

# Functional Overview

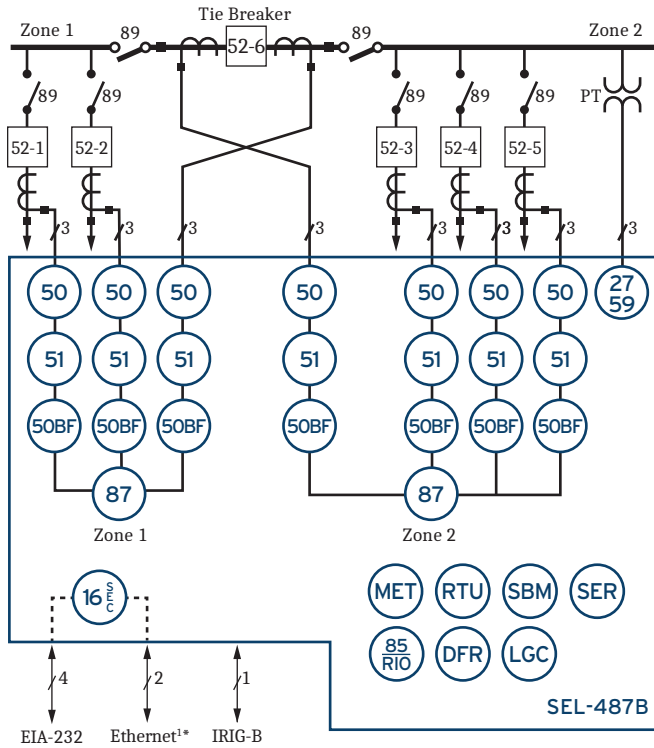

Figure 1 Functional Overview

## ANSI NUMBERS/ACRONYMS AND FUNCTIONS

27/59	Over- and Undervoltage
50	Overcurrent (Phase)
50BF	Breaker Failure Overcurrent
51	Time-Overcurrent (Phase)
87	Current Differential

## ADDITIONAL FUNCTIONS

16 SEC	Access Security (Serial, Ethernet)
85 RIO	SEL MIRRORING Communications
DFR	Event Reports
LGC	SELogic Control Equations
MET	High-Accuracy Metering
RTU	Remote Terminal Unit
SBM	Station Battery Monitor
SER	Sequential Events Recorder

## ADDITIONAL FEATURES

- Open CT Detection
- Three Independent Check Zones
- Disconnect Status and Monitoring Logic for 60 Disconnects
- Single-Relay Application: 2 Three-Phase Zones for as many as 7 Terminals
- Two-Relay Application: 3 Three-Phase Zones for as many as 10 Terminals
- Three-Relay Application: 6 Single-Phase Zones for as many as 21 Terminals

<sup>1</sup> Copper or Fiber Optic      \* Optional Feature

# Protection Features

## Differential Protection

The SEL-487B includes six independent current differential elements. Operating time for internal faults, including high-speed output contact closure, is less than one cycle. Figure 2 shows an example of an internal fault and differential element operation.

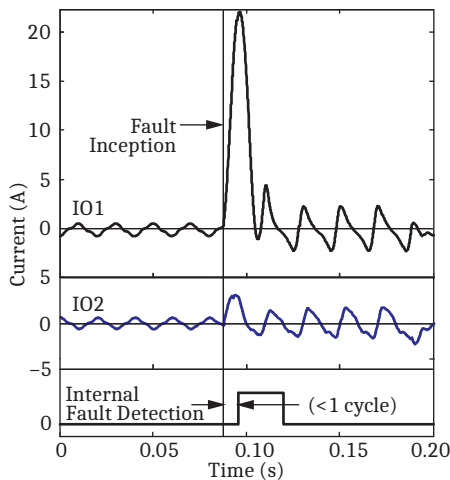

Figure 2 Differential Element Operation in Less Than One Cycle for Internal Faults

Each of the differential elements provides the following:

- Fast operating times for all busbar faults
- Security for external faults with heavy CT saturation
- Security with subsidence current present
- High sensitivity for busbar faults
- Minimum delay for faults evolving from external to internal faults

Figure 3 shows a block diagram of one of the six differential protection elements.

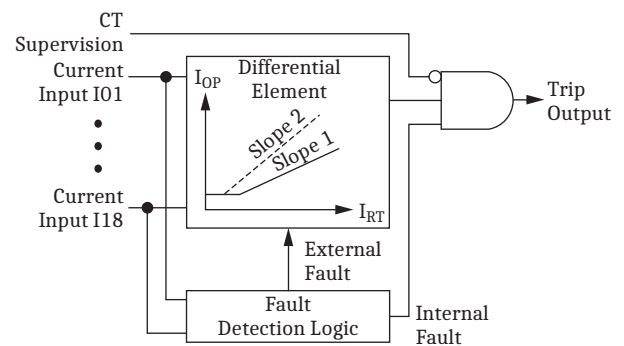
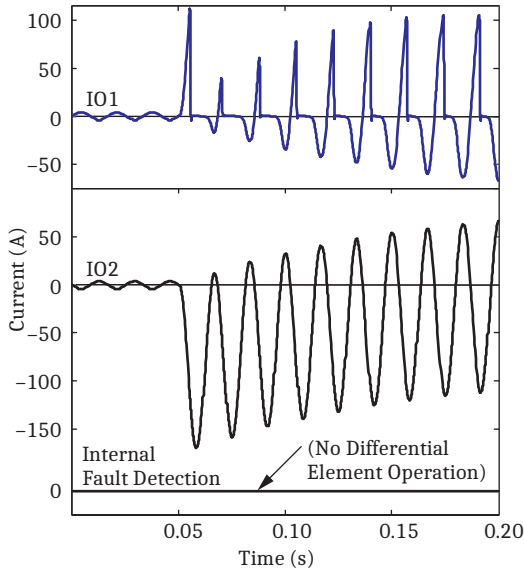

Figure 3 External Fault Detection Logic Increases Differential Element Security

CT saturation is one of the main factors to address when considering relay security. Because of the high sampling rate, the fault detection logic detects external faults in less than 2 ms by comparing the rate of change of the restraint and operating currents. Following the detection of an external fault, the relay enters a high-security mode, during which it dynamically selects a higher slope for the differential elements (see *Figure 3*). *Figure 4* shows an external fault with heavy CT saturation, without differential element operation.

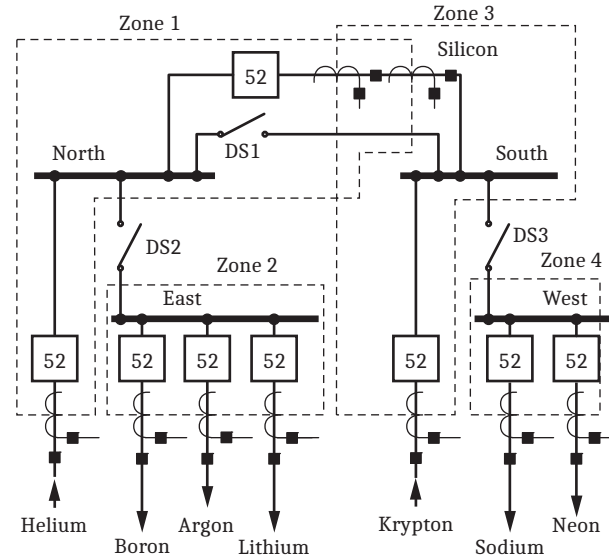

**Figure 4 Differential Element Does Not Operate for External Fault With Heavy CT Saturation**

## Dynamic Zone Configuration

The SEL-487B dynamically assigns the input currents to the correct differential elements without the need for auxiliary relays. Connect the digital inputs from the busbar disconnect auxiliary contacts directly to the relay. SELOGIC control equations and zone selection logic will correctly assign the currents to the differential elements, even for complex bus arrangements such as the one in *Figure 5*.

Busbar configuration information, as a function of the disconnect status, is readily available. *Figure 6* depicts the response of the relay to the **ZONE** command, showing the terminals and bus zones assigned to each protection zone.

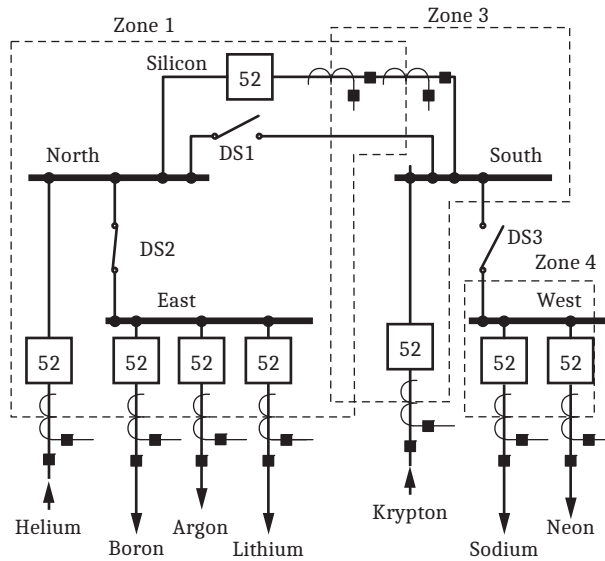

**Figure 5 Bus-Zone Protection Based on Disconnect Switch Positions**

```

=>>ZONE <Enter>
BUS PROTECTION
Rinadel Station
Terminals in Protection Zone 1
HELIUM SILICON
Bus-Zones in Protection Zone 1
NORTH
Terminals in Protection Zone 2
BORON ARGON LITHIUM
Bus-Zones in Protection Zone 2
EAST
Terminals in Protection Zone 3
SILICON KRYPTON
Bus-Zones in Protection Zone 3
SOUTH
Terminals in Protection Zone 4
SODIUM NEON
Bus-Zones in Protection Zone 4
WEST
=>>
    
```

**Figure 6 Result of ZONE Command, Indicating the Protection Zone Configuration According to Disconnect Switch Positions**



**Figure 7 Bus Arrangement With Disconnect DS2 Closed; the New Zone 1 That Includes Bus Zones North and East**

```

=>>ZONE <Enter>
BUS PROTECTION
Rinadel Station
Terminals in Protection Zone 1
HELIUM SILICON BORON ARGON
LITHIUM
Bus-Zones in Protection Zone 1
NORTH EAST
Terminals in Protection Zone 3
SILICON KRYPTON
Bus-Zones in Protection Zone 3
SOUTH
Terminals in Protection Zone 4
SODIUM NEON
Bus-Zones in Protection Zone 4
WEST
=>>
    
```

**Figure 8 Result of ZONE Command, Showing the Protection Zone Configuration After Zone 1 Merges With Zone 2**

Closing disconnect DS2 combines Zone 1 and Zone 2, resulting in a single zone. Figure 7 shows the new protection zone configuration. In this combination, Zone 1 includes North and East bus-zones. Figure 8 shows the new Zone 1 that includes bus-zones North and East.

## Zone Selection Logic

Busbar protection requires assignment of the correct current values to the appropriate differential elements as a function of user-defined conditions. To achieve this, the SEL-487B employs a two-step process:

- Evaluates the user-defined conditions.
- Assigns the currents to the differential element of the appropriate zone.

Current assignment conditions vary from simple to complex. A simple condition would be a statement such as “always include this terminal in the differential calcula-

tions.” A more complex condition statement could be “when Disconnect 2 is closed, and the transfer disconnect is open.”

SELOGIC control equations provide the mechanism by which the user enters the conditions for assigning the currents to the differential elements when these conditions are met. When a SELOGIC control equation becomes true (e.g., the disconnect is closed), the relay dynamically assigns the current to the differential elements. Conversely, when the SELOGIC control equation is false (the disconnect is open), the relay dynamically removes the currents from the differential elements. This is also true for the trip output. When the SELOGIC control equation of a terminal is false, the relay issues no trip signal to that terminal. Table 1 shows a simple case where the disconnect status is the only condition for the relay to consider.

**Table 1 Conditions for Automatic Terminal Assignment**

Example of Condition	SELOGIC Control Equation Result	Consider Terminal in Protection Calculations?	Issue Trip?
Disconnect is open	False	No	No
Disconnect is closed	True	Yes	Yes

## End-Zone Protection

To illustrate the flexibility of use of SELOGIC control equations for user-defined conditions, consider the ease of achieving end-zone protection with the SEL-487B.

Figure 9 shows fault F1 between an open circuit breaker and CT of a feeder at a substation. This area is a dead zone because neither busbar protection nor local line protection can clear this fault; the remote end of the feeder must clear this fault. Because the feeder circuit breaker is already open, operation of the busbar protection serves no purpose. The busbar protection must not operate for this fault.

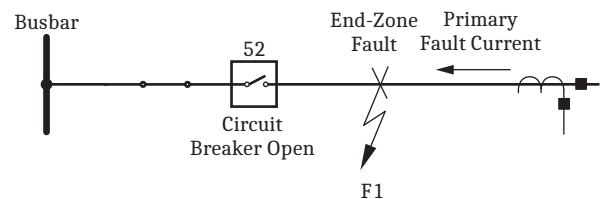

**Figure 9 Fault Between Breaker and CT**

By including the circuit breaker auxiliary contact in one of the SELOGIC control equations (Figure 10), we can cause the value of the SELOGIC control equation to be false when the circuit breaker is open, removing the current from the differential element calculations. This capability ensures stability of the busbar protection. By our use of SELOGIC control equations and normal communications channels to configure the protection system, the relay sends a trip signal to the remote end of the feeder.

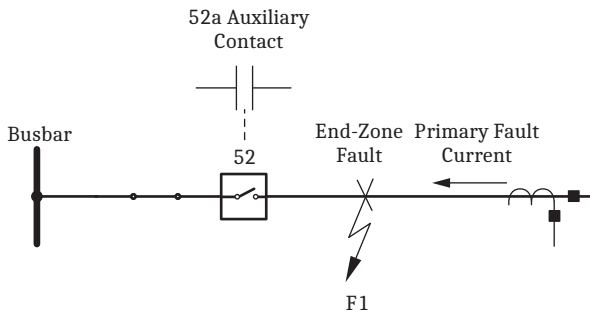

**Figure 10 Bus Protection Is Not Affected by Fault, F1; Use Transfer Trip to Clear the Fault**

### Check Zones

The SEL-487B provides three completely independent check zones, each with its own adaptive differential element. Supervise zone differential elements by using the independent check zones to monitor all incoming sources and outgoing feeders on a per-phase basis. During an internal fault, the check zone differential element will assert. During an external fault, the check zone element will remain deasserted.

### CT Supervision

Open or shorted current transformers produce equal and opposite changes in restraint and operate current. The advanced CT supervision in the SEL-487B monitors differential zone restraint and operating current for these

changes, to provide rapid and dependable detection of open or shorted CT conditions. Use the CT supervision logic in zone trip equations.

## Disconnect Status Monitor

Figure 11 shows the disconnect open and close contact relationship. During the open-to-close operation, the 89b contact must open (disconnect is CLOSED) during the transition zone before the main contact arcing starts. The 89a contact must close in this transition zone.

During the close-to-open operation, the 89b contact must close during the transition zone after the main contact arcing is extinguished (disconnect is OPEN), as shown in Figure 11. The 89a contact must open in this transition zone.

Table 2 shows the four possible disconnect auxiliary contact combinations and how the relay interprets each combination.

**Table 2 Disconnect Status as a Function of the Auxiliary Contacts**

89a	89b	Relay 89 Status Interpretation
0	0	Closed
0	1	Open
1	0	Closed
1	1	Closed

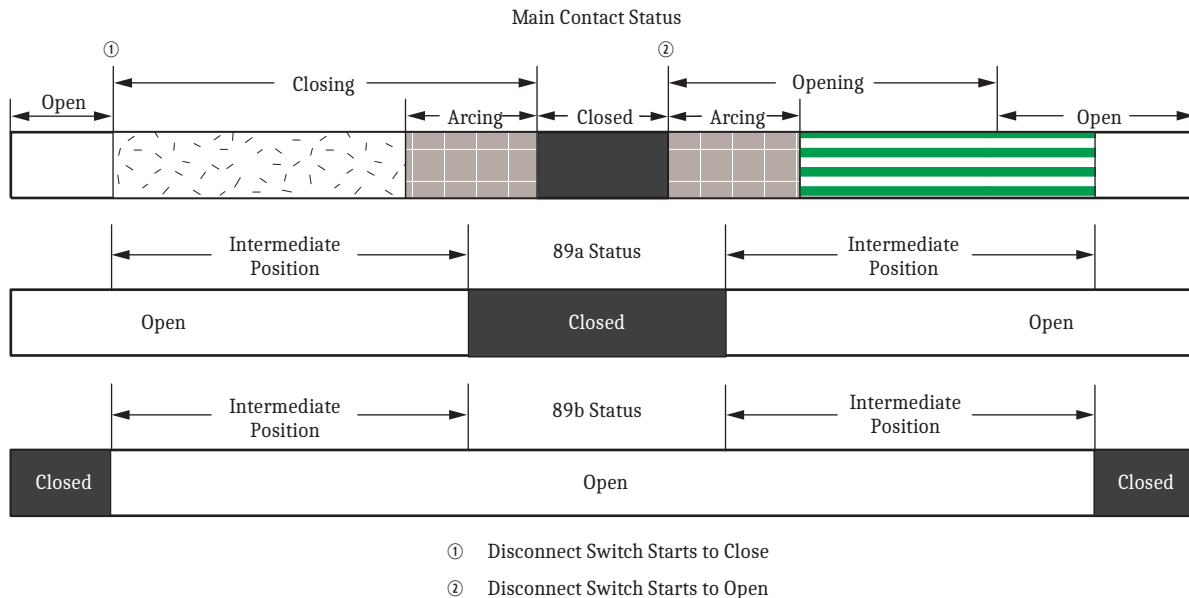

**Figure 11 Disconnect Switch Auxiliary Contact Requirements for the Zone Selection Logic; No CT Switching Required**

# Tie-Breaker Configurations

Figure 12, Figure 13, and Figure 14 show three tie-breaker schemes:

- Two CTs configured in overlap (Figure 12)
- A single CT with two cores configured in overlap (Figure 13)
- Two CTs configured with a differential element across the breaker (Figure 14)

Configure any one of these schemes without using external auxiliary relays. Figure 12 and Figure 13 also show the tie breaker closing onto an existing fault, F1. The SEL-487B includes tie-breaker logic to prevent the loss of both zones for this fault.

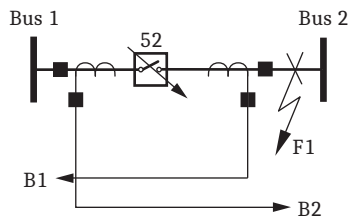

**Figure 12 Two CTs Configured in Overlap**

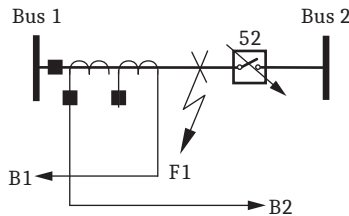

**Figure 13 A Single CT With Two CT Cores Configured in Overlap**

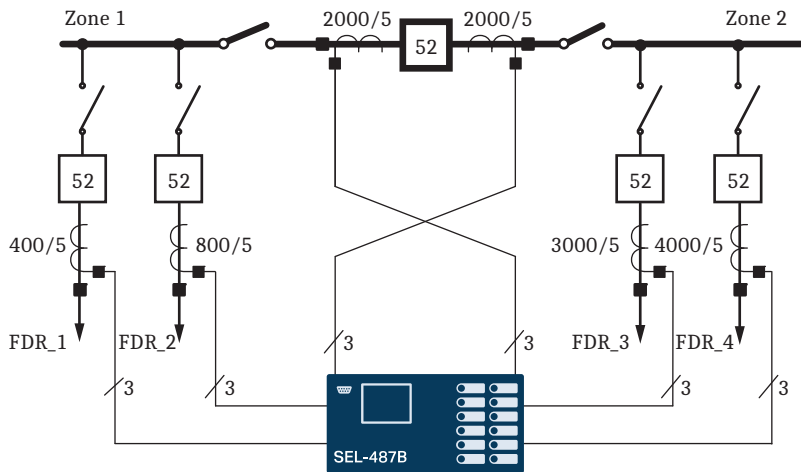

**Figure 15 Single SEL-487B Protecting Double Bus Sections With Bus Tie Breaker**

Configure one of the differential zones as a differential across the tie breaker. This arrangement has the following advantages:

- Both main zones are secure for a fault between the tie breaker and the CT.
- Only one main zone is tripped for a fault between the tie breaker and the CT (as opposed to both main zones with an overlapping tie-breaker arrangement).

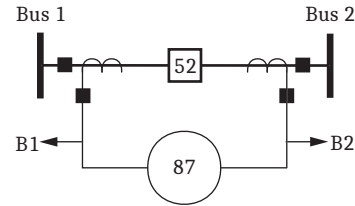
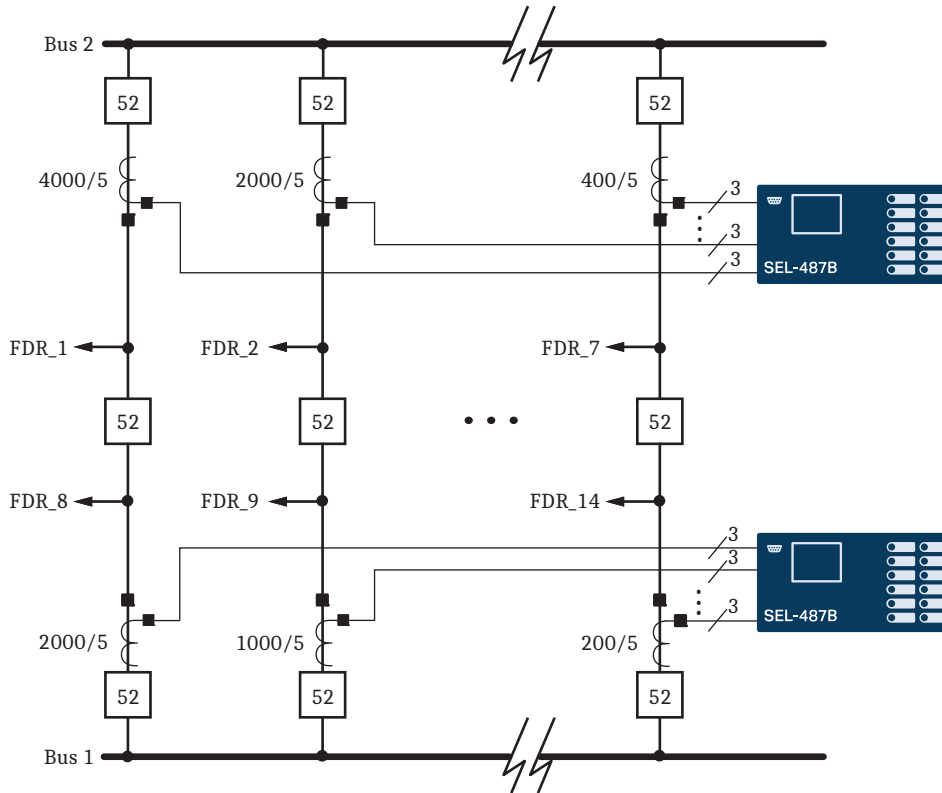

**Figure 14 Two CTs Configured With a Differential Element Across the Breaker**

## Applications

Figure 15 shows a station with double bus sections and a bus tie breaker. Use a single SEL-487B for this application.

For stations with breaker-and-a-half busbar configuration and seven or fewer connections to either busbar, use an SEL-487B for each busbar, as shown in Figure 16.



**Figure 16 Two Single SEL-487B Relays Protecting the Two Busbars in a Breaker-and-a-Half Busbar Configuration**

For stations with 10 to 21 terminals (*Figure 17*), use three separate SEL-487B relays and wire analog current inputs from A-, B-, and C-phases separately into each relay. This way, each of the 21 analog current inputs in each relay measures only one phase, with six dedicated zones of protection available. Each relay operates independently; the only communications among relays are MIRRORING BITS<sup>®</sup> communication and IRIG-B. In this application, operators have complete flexibility because

they can close any disconnect at any time without compromising the busbar protection. This is possible because the relay dynamically computes the station connection replica by using the patented zone-selection algorithm.

*Figure 17* shows a busbar layout consisting of two main busbars and a transfer bus, one busbar coupler, and 20 terminals.



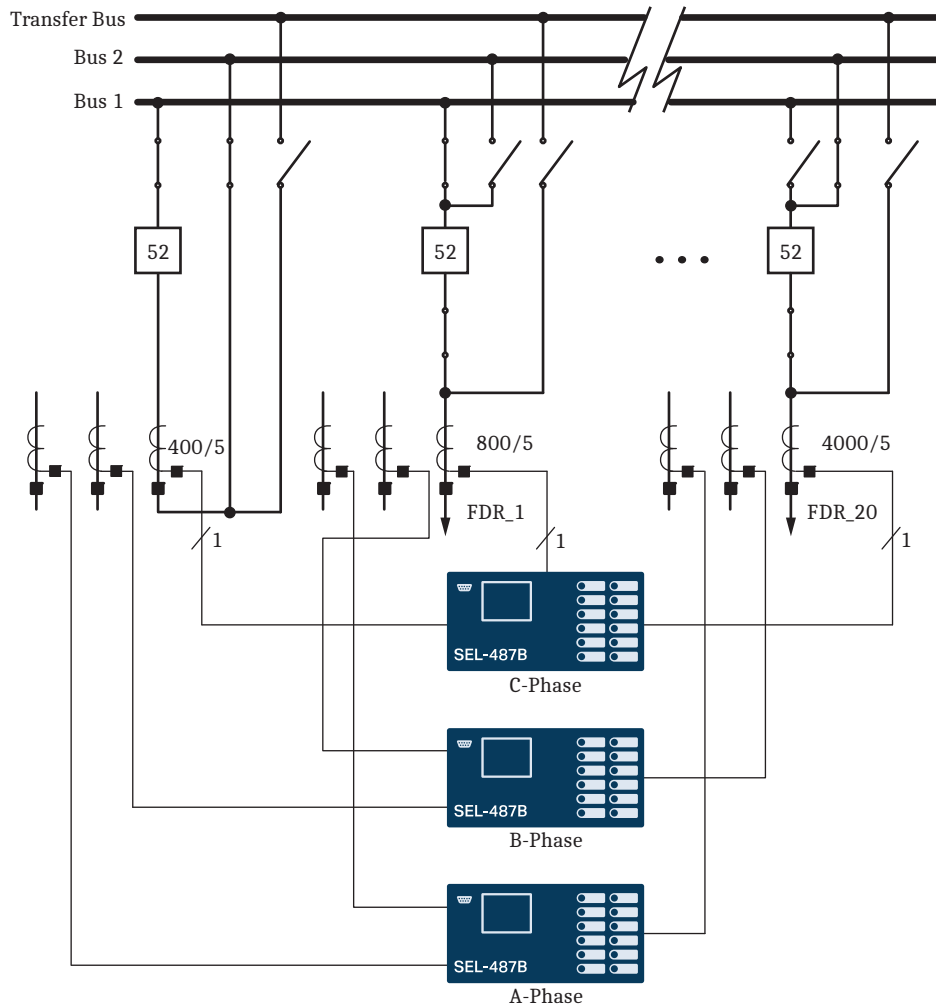

**Figure 17 Three SEL-487B Relays Protect Two Main Busbars and a Transfer Busbar, Bus Coupler, and 20 Terminals**

Optimize your SEL-487B by protecting both HV and LV busbars with three relays. *Figure 18* shows two HV busbars and two LV busbars. Use of four zones for the four

busbars (two HV and two LV) still leaves two zones available in each relay. We can configure independent check zones for HV and LV bus protection supervision.

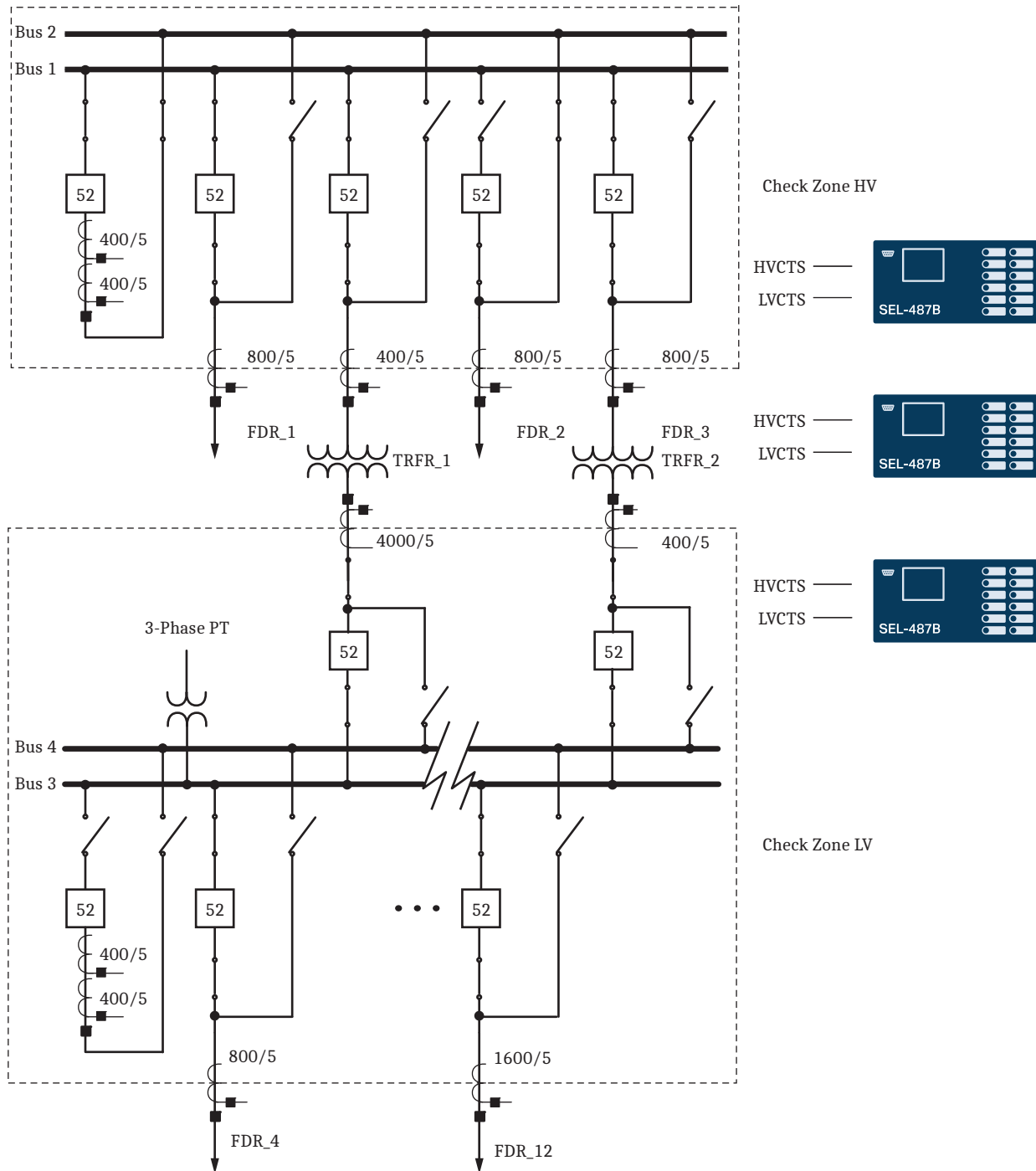

Figure 18 Three SEL-487B Relays Protect Both HV and LV Busbars

## Additional Features

### Front-Panel Display

The LCD shows event, metering, setting, and relay self-test status information.

The LCD is controlled by the navigation pushbuttons (Figure 21), automatic messages the relay generates, and

programmable display points. The rotating display scrolls through any active, nonblank display points. If none are active, the relay scrolls through displays of the differential operating and restraint quantities, the terminals in each enabled zone, and the primary current and voltage values. Each display remains for 5 seconds before the dis-

play continues scrolling. Any message the relay generates because of an alarm condition takes precedence over the rotating display.

Figure 19, Figure 20, and Figure 21 show close-up views of the front panel of the SEL-487B. The standard front panel includes a 128 x 128 pixel, 3" x 3" LCD screen; 18 LED target indicators; and 8 direct-action control pushbuttons with indicating LEDs for local control functions. You can use easily changed slide-in labels to custom configure target and pushbutton identification. Figure 20 shows the expanded SEL-487B front panel. The optional expanded SEL-487B front panel provides the same LCD screen with more latching target LEDs and programmable pushbuttons. When you order the optional front panel, the SEL-487B provides 24 tricolor LEDs and 12 programmable pushbuttons with indicating LEDs. Use the capabilities of the expanded SEL-487B front panel to integrate a wide range of control and system annunciation functions.

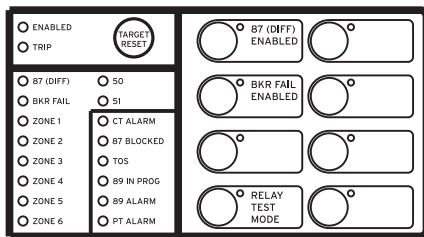

**Figure 19 Standard Front-Panel Configurable Labels, Programmable Targets and Controls for Customized Applications**

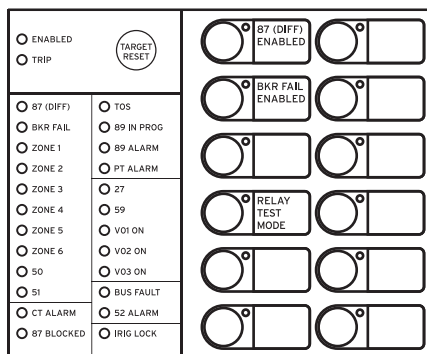

**Figure 20 Optional Front Panel With 24 Tricolor Target LEDs and 12 Pushbuttons**

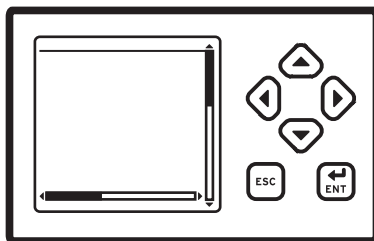

**Figure 21 Front-Panel Display and Pushbuttons**

## Status and Trip Target LEDs

The SEL-487B includes programmable target LEDs, as well as programmable direct-action control pushbuttons/LEDs on the front panel. Figure 19 and Figure 20 show these targets.

The SEL-487B features a versatile front panel that you can customize to fit your needs. Use SELOGIC control equations and slide-in configurable front-panel labels to change the function and identification of target LEDs and operator control pushbuttons and LEDs. The blank slide-in label set is included with the SEL-487B. You can use templates supplied with the relay or hand label supplied blank labels and print label sets from a printer.

## Control Inputs and Outputs

Order the 9U chassis version of the SEL-487B to equip the relay with a maximum of four interface boards. With four interface boards, the relay has a total of 103 inputs (72 common inputs and 31 independent inputs) and 40 outputs (24 high-speed, high-current interrupting outputs and 16 standard outputs). Order the 7U chassis version of the SEL-487B to equip the relay with a maximum of two interface boards. With two interface boards, the relay has a total of 55 inputs (36 common inputs and 19 independent inputs) and 24 outputs (12 high-speed, high-current interrupting outputs and 12 standard outputs).

The 7U and 9U chassis options for the SEL-487B both contain 21 current inputs and three voltage inputs. With the flexibility of the expanded SELOGIC control equations, you need no external auxiliary relays to configure the relay for complex busbar arrangements. The SEL-487B provides station-wide protection by using as many as six zones of differential protection, advanced zone selection algorithms, and per-terminal breaker failure and overcurrent protection.

## Time Synchronization

To synchronize the relays in a three-relay application, use the unique IN and OUT IRIG-B connectors installed on each relay for the IRIG-B signal. Referring to the External Source connections in Figure 22, connect the IRIG-B signal to the IN connector of Relay A to update the time. Connect the OUT connector of Relay A to the IN connector of Relay B to update the time in Relay B. Use a similar connection between Relay B and Relay C to update the time in Relay C. In the absence of an external IRIG-B signal, connect the relays as shown by the Internal Source connections in Figure 22. Connected this way, Relay B and Relay C synchronize to the internal clock of Relay A. The event reports the different relays generate are time-stamped to within 10  $\mu$ s of each other.

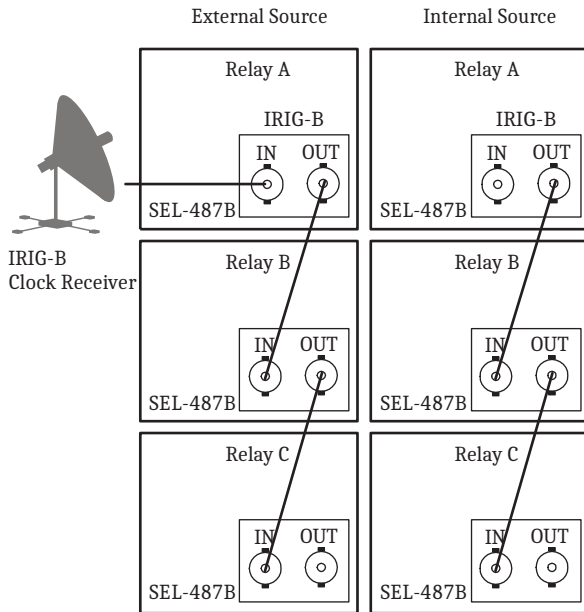

**Figure 22 Time Synchronize SEL-487B Relays With or Without External Clock Source**

## Communications Features

See *Specifications on page 22* for specific supported protocols.

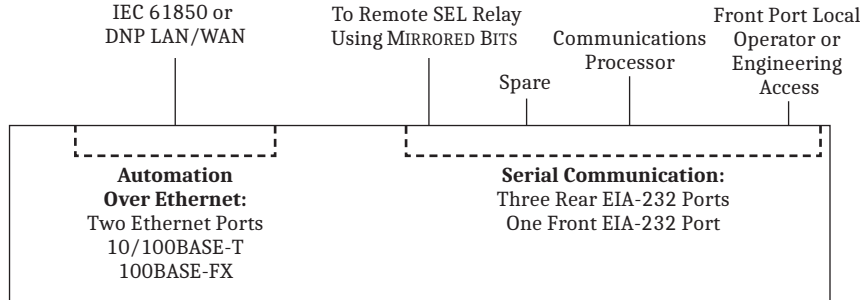

**Figure 23 System Functional Overview**

The relay offers the following communications features:

- Four independent EIA-232 serial ports.
- Access to event history, relay status, and meter information from the communications ports.
- Password-controlled settings management and automation features.
- SCADA interface capability, including FTP, IEC 61850 Edition 2.1, DNP3 LAN/WAN (via Ethernet), and DNP3 (via serial port). The relay does not require special communications software. You only need ASCII terminals, printing terminals, or a computer supplied with terminal emulation and a serial communications port.

## Ethernet Card

Use popular Telnet applications for easy terminal communications with SEL relays and other devices. Transfer data at high speeds for fast file uploads. The Ethernet card communicates using FTP applications for easy and fast file transfers.

Communicate with SCADA by DNP3 and other substation IEDs by using IEC 61850 Manufacturing Message Specification (MMS) and GOOSE messaging.

Choose Ethernet connection media options for primary and standby connections:

- 10/100BASE-T twisted pair network
- 100BASE FX fiber-optic network

## Telnet and FTP

Use Telnet to access relay settings, metering, and event reports remotely by using the ASCII interface. Use FTP to transfer settings files to and from the relay via the high-speed Ethernet port.

## DNP3 LAN/WAN

DNP3 LAN/WAN provides the relay with DNP3 Level 2 Outstation functionality over Ethernet. Configure DNP3 data maps for use with specific DNP3 masters.

## PTP

The Ethernet card provides the ability for the relay to accept IEEE 1588 PTPv2 for data time synchronization. PTP support includes the Default, Power System, and Power Utility Automation Profiles. When connected directly to a grandmaster clock providing PTP at 1-second synchronization intervals, the relay can be synchronized to an accuracy of  $\pm 100$  ns in the PTP time scale.

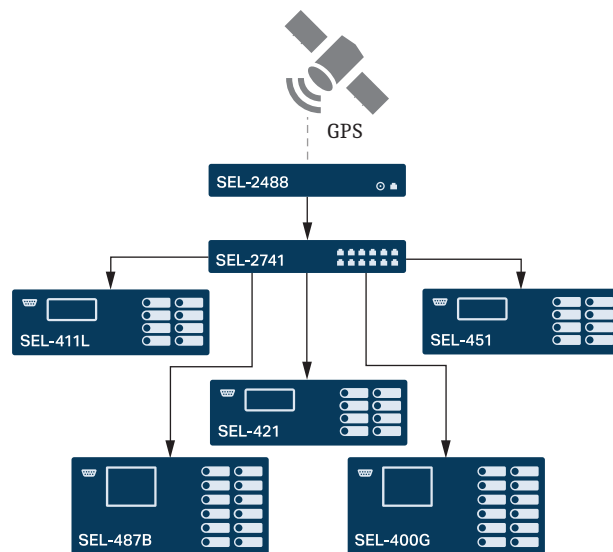

Figure 24 Example PTP Network

## SNTP Time Synchronization

Use SNTP to synchronize relays to as little as  $\pm 1$  ms with no time source delay. Use SNTP as a primary time source, or as a backup to a higher accuracy time input to the relay.

## PRP

Use PRP to provide seamless recovery from any single Ethernet network failure, in accordance with IEC 62439-3. The Ethernet network and all traffic are fully duplicated with both copies operating in parallel.

## HTTP Web Server

The relay can serve read-only webpages displaying certain settings, metering, and status reports. The web server also allows quick and secure firmware upgrades over Ethernet. As many as four users can access the embedded HTTP server simultaneously.

## IEC 61850 Ethernet Communications

IEC 61850 Ethernet-based communication protocols provide interoperability between intelligent devices within the substation. Standardized logical nodes allow interconnection of intelligent devices from different manufacturers for monitoring and control of the substation.

Eliminate system RTUs by streaming monitor and control information from the intelligent devices directly to remote SCADA client devices.

You can order the relay with IEC 61850 protocol for relay monitor and control functions, including:

- As many as 128 incoming GOOSE messages. You can use the incoming GOOSE messages to control as many as 256 control bits in the relay with  $< 3$  ms latency from device to device depending on network design. These messages provide binary control inputs to the relay for high-speed control functions and monitoring.
- As many as eight outgoing GOOSE messages. Configure outgoing GOOSE messages for Boolean or analog data such as high-speed control and monitoring of external breakers, switches, and other devices. Boolean data are provided with  $< 3$  ms latency from device to device depending on network design.
- IEC 61850 Data Server. The relay equipped with embedded IEC 61850 Ethernet protocol provides data according to predefined logical node objects. Each relay supports as many as seven simultaneous MMS client sessions, with support to association-based and indexed reports. Relevant Relay Word bits are available within the logical node data, so status of relay elements, inputs, outputs, or SELOGIC control equations can be monitored.
- As many as 256 virtual bits. Configure the virtual bits within GOOSE messaging to represent a variety of Boolean values available within the relay. These bits that the relay receives are available for use in SELOGIC control equations.
- As many as 64 remote analog outputs. Assign the remote analog outputs to virtually any analog quantity available in the relay. You can also use SELOGIC math variables to develop custom analog quantities for assignment as remote analog outputs. Remote

analog outputs that use GOOSE messages provide peer-to-peer transmission of analog data. Each relay can receive as many as 256 remote analog inputs and use those inputs as analog quantities within SELOGIC control equations.

- IEC 61850 standard operating modes. The relay supports Test, Blocked, On, and Off. The relay also supports Simulation mode for added flexibility.

## MMS File Services

This service of IEC 61850 MMS provides support for file transfers completely within an MMS session. All relay files that can be transferred via FTP can also be transferred via MMS file services.

## MMS Authentication

When enabled via a setting in the Configured IED Description (CID) file, the relay requires authentication from any client requesting to initiate an MMS session.

## Architect Software

Use ACCELERATOR Architect SEL-5032 Software to manage the IEC 61850 configuration for devices on the network. This Windows-based software provides easy-

to-use displays for identifying and binding IEC 61850 network data among logical nodes that use IEC 61850-compliant CID files. Architect uses CID files to describe the data available in each relay.

## Serial Communications MIRRORED BITS Communications

The SEL patented MIRRORED BITS technology provides bidirectional relay-to-relay digital communication.

Figure 25 shows two relays with SEL-2815 Fiber-Optic Transceivers that use MIRRORED BITS communications. MIRRORED BITS communications can operate simultaneously on any two serial ports. This bidirectional digital communication creates additional outputs (transmitted MIRRORED BITS) and additional inputs (received MIRRORED BITS) for each serial port operating in the MIRRORED BITS communications mode.

Communicated information can include digital, analog, and virtual terminal data. Virtual terminal allows operator access to remote relays through the local relay. You can use this MIRRORED BITS protocol to transfer information between stations to enhance coordination and achieve faster tripping.

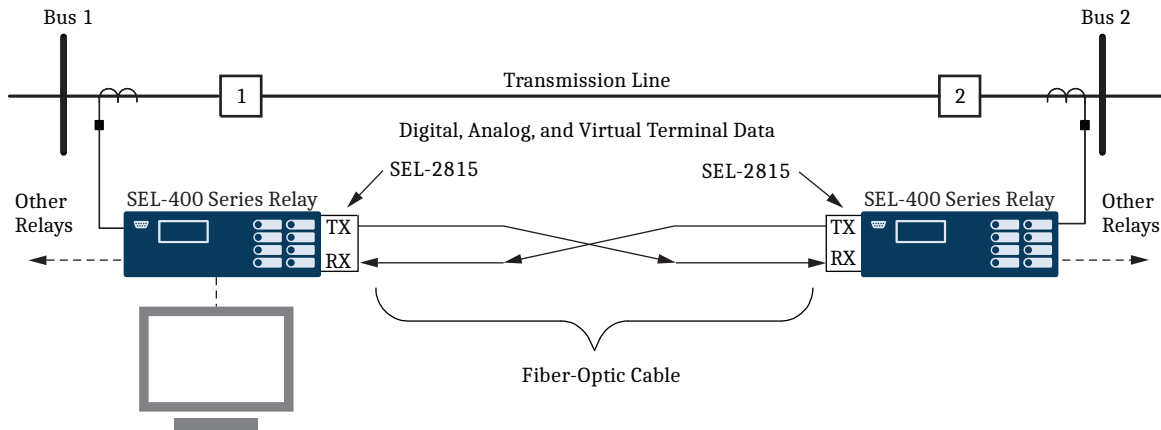

**Figure 25 Integral Communication Provides Secure Protection, Monitoring, and Control as Well as Terminal Access to Both Relays Through One Connection**

## Open Communications Protocols

The relay does not require special communications software. ASCII terminals, printing terminals, or a computer supplied with terminal emulation and a serial communications port are all that is required. Table 3 lists a brief description of the terminal protocols.

**Table 3 Open Communications Protocol**

Type	Description
ASCII	Plain-language commands for human and simple machine communications. Use for metering, setting, self-test status, event reporting, and other functions.
Compressed ASCII	Comma-delimited ASCII data reports. Allows external devices to obtain bay data in an appropriate format for direct import into spreadsheets and database programs. Data are checksum protected.
Extended Fast Meter, Fast Operate, and Fast SER	Binary protocol for machine-to-machine communications. Quickly updates communications processors, RTUs, and other substation devices with metering information, bay element, I/O status, time-tags, open and close commands, and summary event reports. Data are checksum protected. Binary and ASCII protocols operate simultaneously over the same communications lines so that control operator metering information is not lost while a technician is transferring an event report.
Ymodem	Support for reading event, settings, and oscillography files.
Optional DNP3 Level 2 Outstation	DNP with point remapping. Includes access to metering data, protection elements, contact I/O, targets, SER, relay summary event reports, and settings groups.
MIRRORED BITS	SEL protocol for exchanging digital and analog information among SEL relays and for use as low-speed terminal connection.
IEC 61850	Ethernet-based international standard for interoperability between intelligent devices in a substation.
PRP	PRP provides redundant Ethernet network capabilities for seamless operation in the event of loss to one network.
SNTP	Ethernet-based SNTP for time synchronization among relays.
FTP and Telnet	Use Telnet to establish a terminal-to-relay connection over Ethernet. Use FTP to move files in and out of the relay over Ethernet.

## Automation

### Flexible Control Logic and Integration Features

Use the control logic to perform the following:

- Replace traditional panel control switches
- Eliminate remote terminal unit (RTU)-to-bay wiring
- Replace traditional latching relays
- Replace traditional indicating panel lights

Eliminate traditional panel control switches with 64 local control points. Set, clear, or pulse local control points with the front-panel pushbuttons and display. Program the local control points to implement your control scheme via SELOGIC control equations. Use the local control points for such functions as trip testing, enabling/disabling reclosing, and tripping/closing circuit breakers.

Eliminate RTU-to-bay wiring with 96 remote control points per relay. Set, clear, or pulse remote control points via serial port commands. Incorporate the remote control points into your control scheme via SELOGIC control equations. Use remote control points for SCADA-type control operations (e.g., trip, close, settings group selection).

Replace traditional latching relays for such functions as remote control enable with 64 latching control points. Program latch set and latch reset conditions with SELOGIC control equations. Set or reset the latch control points via

control inputs, remote control points, local control points, or any programmable logic condition. The relay retains the states of the latch control points after turning on following a power interruption.

Replace traditional indicating panel lights and switches with as many as 24 latching target LEDs and as many as 12 programmable pushbuttons with LEDs. Define custom messages (i.e., BREAKER OPEN) to report power system or relay conditions on the large format LCD. Control displayed messages with SELOGIC control equations by driving the LCD via any logic point in the relay.

### SELOGIC Control Equations With Expanded Capabilities and Aliases

Expanded SELOGIC control equations put relay logic in the hands of the engineer. Assign inputs to suit your application, logically combine selected bay elements for various control functions, and assign outputs to your logic functions.

Programming SELOGIC control equations consists of combining relay elements, inputs, and outputs with SELOGIC control equation operators (*Table 4*). Any element in the Relay Word can be used in these equations. For complex or unique applications, these expanded SELOGIC functions allow superior flexibility.

**Table 4 SELogic Control Equation Operators**

Operator Type	Operators	Comments
Boolean	AND, OR, NOT	Allows combination of measuring units.
Edge Detection	F_TRIG, R_TRIG	Operates at the change of state of an internal function.
Comparison	>, >=, =, <=, <, <>	
Arithmetic	+, -, *, /	Uses traditional math functions for analog quantities in an easily programmable equation.
Numerical	ABS, SIN, COS, LN, EXP, SQRT, LOG	
Precedence Control	( )	Allows multiple and nested sets of parentheses.
Comment	#, (* *)	Provides for easy documentation of control and protection logic.

Use the relay alias capability to assign more meaningful names to analog and Boolean quantities. This improves the readability of customized programming. Use as many as 200 aliases to rename any digital or analog quantity. The following is an example of possible applications of SELOGIC control equations that use aliases.

```

=>>SET T <Enter>
1: PMV01, THETA
(assign the alias "THETA" to math variable PMV01)

2: PMV02, TAN
(assign the alias "TAN" to math variable PMV02)

=>>SET L <Enter>
1: # CALCULATE THE TANGENT OF THETA
2: TAN:=SIN(THETA)/COS(THETA)
(use the aliases in an equation)

```

Add programmable control functions to your relay and automation systems. New functions and capabilities enable using analog values in conditional logic statements. The following are examples of possible applications of SELOGIC control equations with expanded capabilities.

- ▶ Emulate a motor-driven reclose timer, including stall, reset, and drive-to-lockout conditions.
- ▶ Scale analog values for SCADA retrieval.
- ▶ Initiate remedial action sequence based on load flow before fault conditions.
- ▶ Interlock breakers and disconnect switches.
- ▶ Restrict breaker tripping in excessive duty situations without additional relays.
- ▶ Hold momentary change-of-state conditions for SCADA polling.

## Metering and Monitoring

Access a range of useful information in the relay with the metering function. Metered quantities include fundamental primary and secondary current and voltage magnitudes and angles for each terminal. Secondary quantities also include the PT ratio and CT ratio of each terminal. Zone information displays primary current and voltage magnitudes and angles for each terminal and also includes the polarity of each CT and the bus zones in each of the protective zones at the station. The same information is available in secondary quantities and includes both the CT ratio and polarity. Differential metering shows the operating and restraint currents, as well as the reference current, for each zone.

**Table 5 Flexible Metering Capabilities and Large Screen Display Eliminate Need for Panel Instruments (Sheet 1 of 2)**

Capabilities	Description
V01, V02, V03	Fundamental phase voltage magnitude and angle in primary and secondary values
I01, I02, . . . , I21	Fundamental phase current magnitude and angle in primary and secondary values

**Table 5 Flexible Metering Capabilities and Large Screen Display Eliminate Need for Panel Instruments (Sheet 2 of 2)**

Capabilities	Description
IOP, IRT, IREF	Operating and restraint currents for each zone, check zone, and the reference current
Bus Zones in Protection Zone <i>n</i>	Names of the bus-zones in Protection Zone <i>n</i> (where <i>n</i> = 1 to 6)
PTR, CTR	PT ratio and CT ratio for each terminal
POL	Polarity of each CT

## Event Reporting and SER

Event reports and SER features simplify post-fault analysis and help improve your understanding of both simple and complex protective scheme operations. These features also aid in testing and troubleshooting relay settings and protective schemes.



## Oscillography and Event Reporting

In response to a user-selected internal or external trigger, the voltage, current, and element status information contained in each event report confirms relay, scheme, and system performance for every fault. The relay provides sampling rates as fast as 8 kHz for analog quantities in a COMTRADE file format, as well as eight-sample-per-cycle and four-sample-per-cycle event reports. The relay stores as much as 3 seconds of 8 kHz event data. The relay supports inclusion of user-configurable analogs in the events. Reports are stored in nonvolatile memory. Relay settings operational in the relay at the time of the event are appended to each event report.

Each relay provides event reports for analysis with software such as SEL-5601-2 SYNCHROWAVE<sup>®</sup> Event Software. With SYNCHROWAVE Event, you can display events from several relays to make the fault analysis easier and more meaningful. Because the different relays time-stamp the events with values from their individual clocks, be sure to time synchronize the relay with an IRIG-B clock input or PTP source to use this feature.

## Event Summary

Each time the relay generates a standard event report, it also generates a corresponding event summary. This is a concise description of an event that includes the following information:

- Relay/terminal identification
- Event date and time
- Event type
- Event number
- Time source
- Active settings group
- Targets asserted during the fault
- Current magnitudes and angles for each terminal
- Voltage magnitudes and angles
- Terminals tripped for this fault
- Breaker Status (open/close)
- Bus-zones in Protection Zone  $n$  ( $n = 1-6$ )

With an appropriate setting, the relay sends an event summary in ASCII text automatically to one or more serial ports each time an event report is triggered.

## SER

Use this feature to gain a broad perspective of relay element operation. Items that trigger an SER entry are selectable and can include as many as 250 monitoring points, such as I/O change-of-state and element pickup/dropout. The relay SER stores the latest 1000 events.

## Analog Signal Profiling

The relay provides analog signal profiling for as many as 20 analog quantities. Select any analog quantity measured or calculated by the relay for analog signal profiling. You can select signal sampling rates of 1, 5, 15, 30, and 60 minutes through settings. The analog signal profile report provides a comma-separated variable (CSV) list that you can load into any spreadsheet or database for analysis and graphical display.

SELOGIC enable/disable functions can start and stop signal profiling based on Boolean or analog comparison conditions.

## Substation Battery Monitor for DC Quality Assurance

The relay measures and reports the substation battery voltage for one battery system. The battery monitor supports programmable threshold comparators and associated logic provides alarm and control for one battery and charger. The relay also provides dual ground detection. Monitor dc system status alarms with an SEL communications processor and trigger messages, telephone calls, or other actions.

The measured dc voltage is reported in the METER display via serial port communications and in the event report. Use the event report data to see an oscillographic display of the battery voltage. Monitor the substation battery voltage drops during trip, close, and other control operations.

# Diagrams and Dimensions

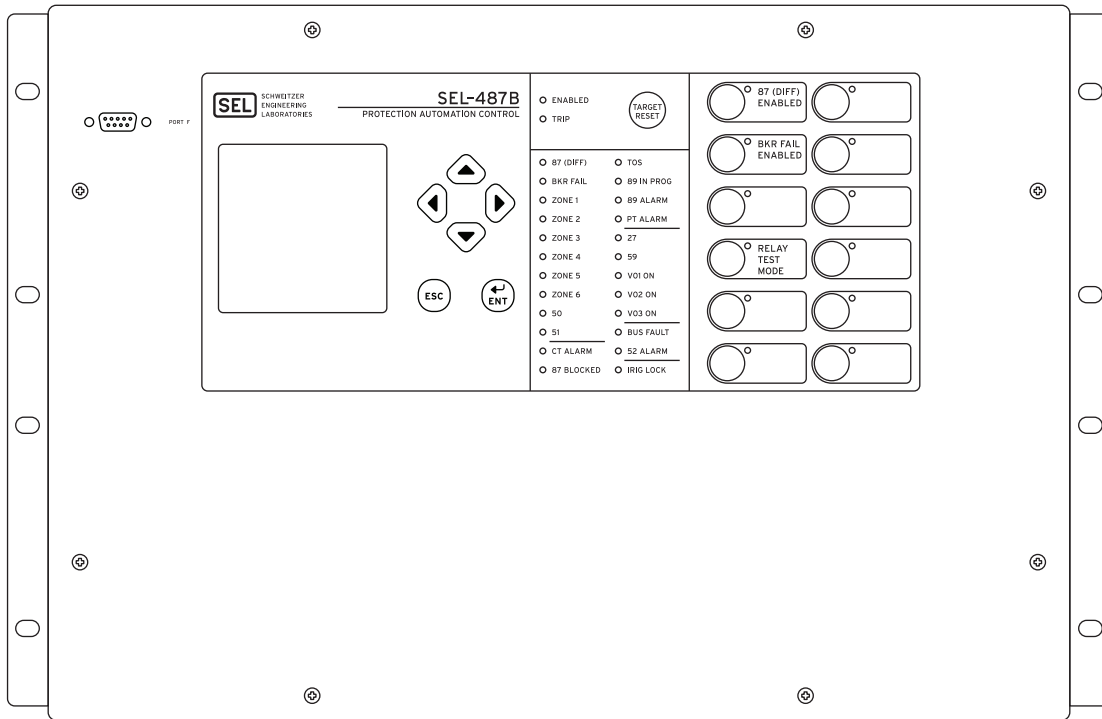

17093c

**Figure 26 7U Front Panel, Rack-Mount Option**

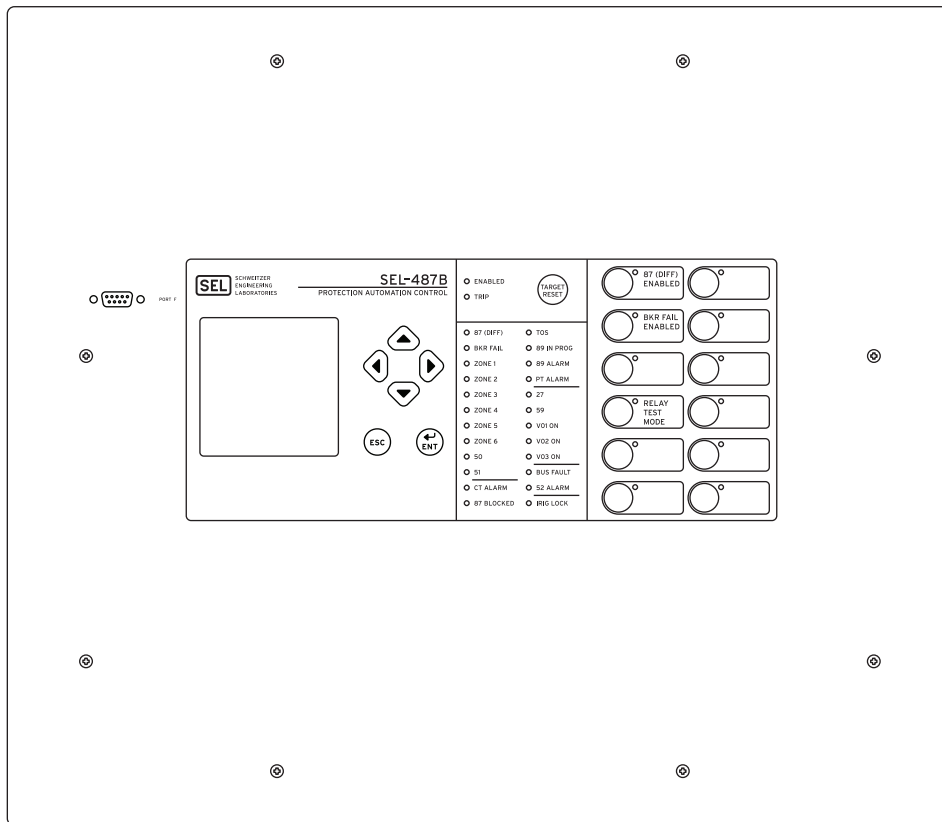

17094c

**Figure 27 9U Front Panel, Panel-Mount Option**

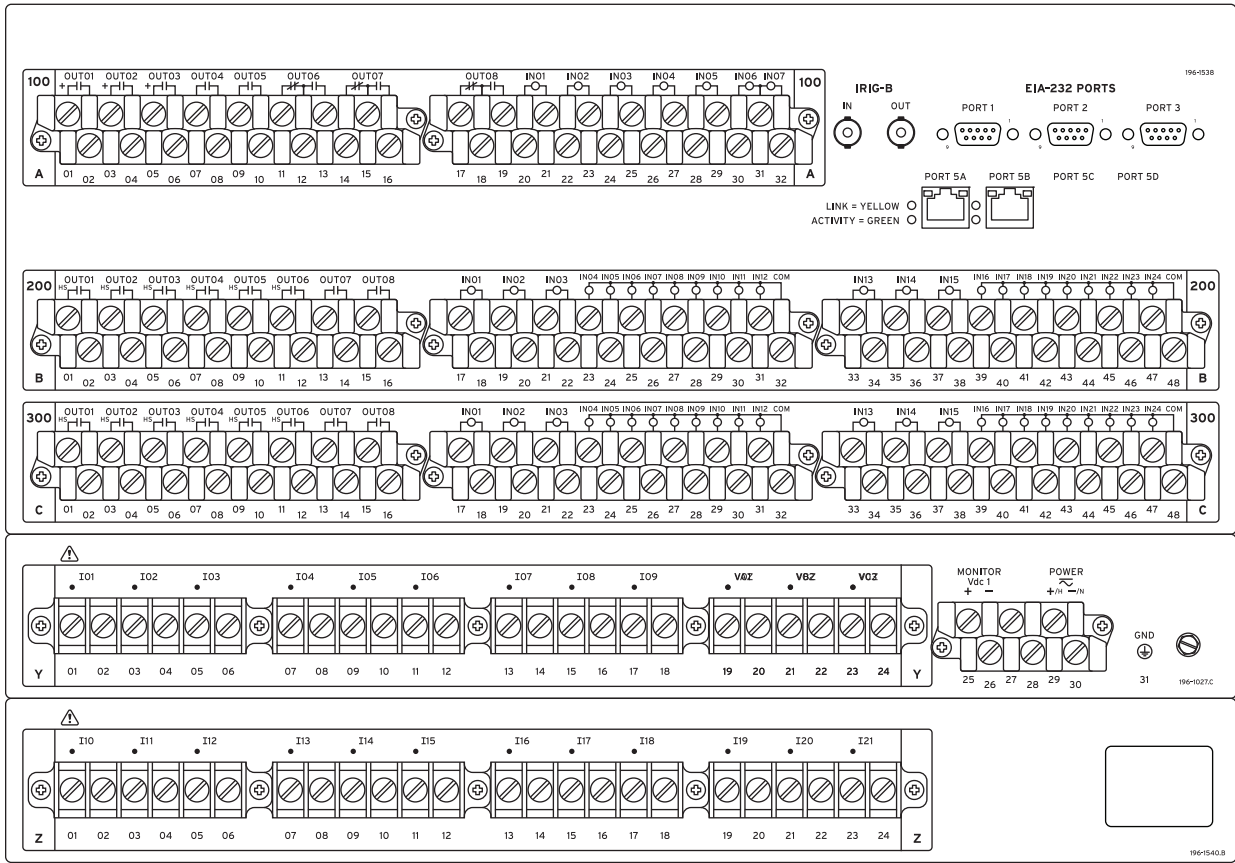
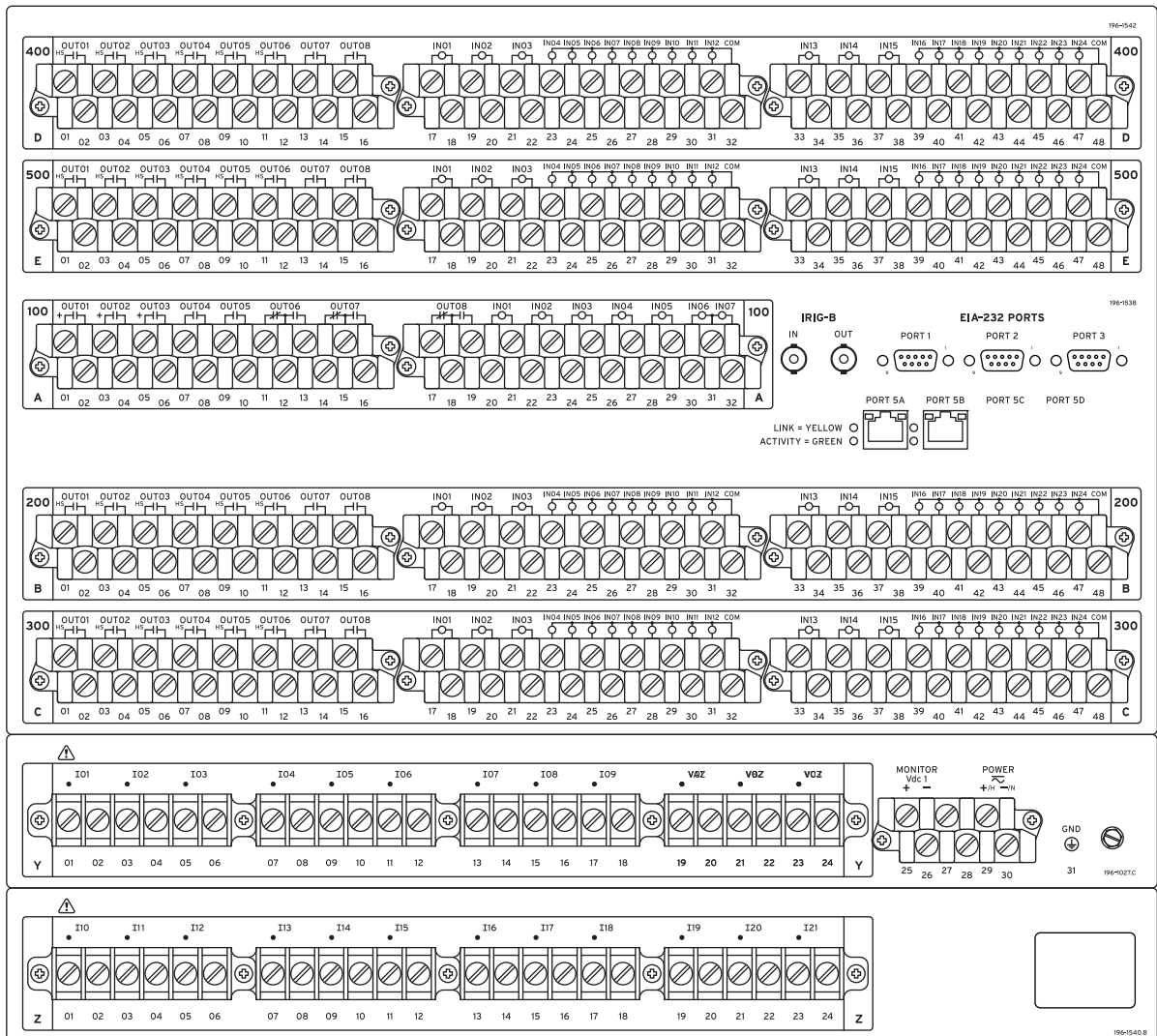

Figure 28 7U Rear Panel, Main Board With Two (INT4) I/O Boards



17094c

Figure 29 9U Rear Panel, Main Board With Four (INT4) I/O Boards

## RACK-MOUNT CHASSIS

## PANEL-MOUNT CHASSIS

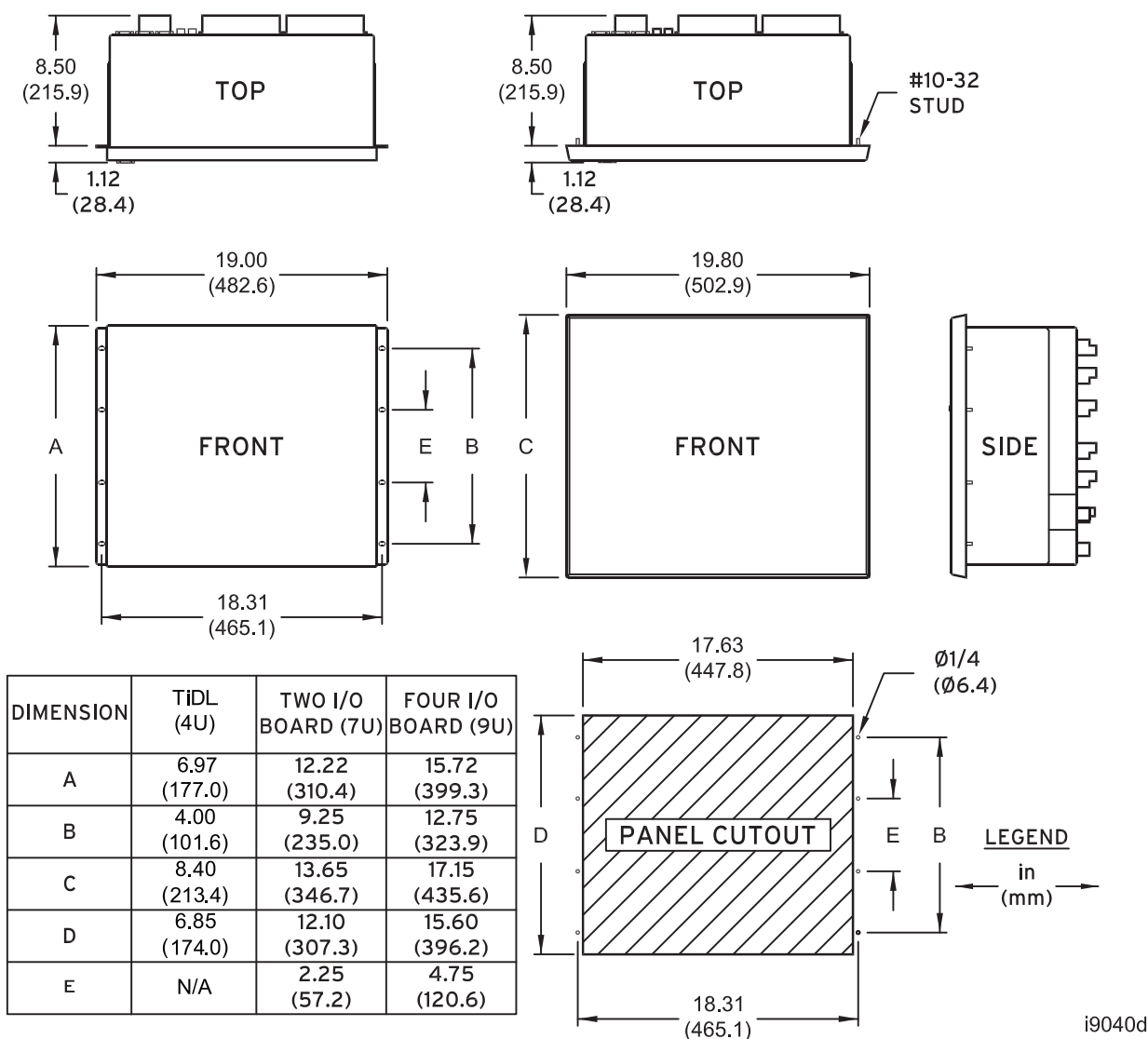

Figure 30 Dimensions for Rack- and Panel-Mount Models

## Models and Options

Consider the following options when ordering and configuring the SEL-487B.

- Chassis size
  - 7U and 9U (U is one rack unit—44.45 mm or 1.75 in)

The 9U chassis size supports as many as four additional expansion I/O boards. For applications not requiring as many contact I/O points, the 7U chassis size supports as many as two additional expansion I/O boards. For the three-relay application, three units are required. Features not labeled as ordering options are standard.

Table 6 Interface Board Information (Sheet 1 of 2)

Board Name	Inputs	Description	Outputs	Description
INT4	18	Two sets of 9 common optoisolated, level-sensitive	6	High-speed, high-current interrupting, Form A
	6	Optoisolated, independent, level-sensitive	2	Standard Form A

**Table 6 Interface Board Information (Sheet 2 of 2)**

Board Name	Inputs	Description	Outputs	Description
INT4	18	Two sets of 9 common optoisolated, level-sensitive	8	Standard Form A
	6	Optoisolated, independent, level-sensitive		

- Voltage ranges for the inputs on the main board as well as for the inputs on the four interface boards
  - 24 Vdc
  - 48 Vdc
  - 110 Vdc
  - 125 Vdc
  - 220 Vdc
  - 250 Vdc
- Power supply (ordering option)
  - 24–48 Vdc
  - 48–125 Vdc or 110–120 Vac
  - 125–250 Vdc or 110–240 Vac
- Secondary current inputs (ordering option)
  - 1 A nominal or 5 A nominal CT inputs
- Communications card (ordering option)
  - Ethernet card with combinations of 10/100BASE-T and 100BASE-FX media connections on each of two ports
- Secondary voltage inputs (standard feature)
  - 300 V maximum per voltage input
- Ethernet communication protocols
  - Standard (FTP, Telnet, DNP3, PRP)
  - Standard plus IEC 61850 Edition 2.1
- Connector type for PT and CT inputs
  - Screw-terminal block inputs (standard feature)
  - Connectorized (ordering option)
- Conformal coat
  - Conformal coating provides an additional barrier to harsh environments, such as high humidity and airborne contaminants. See [selinc.com/conformalcoating/](http://selinc.com/conformalcoating/) for more information.

Contact the SEL factory or your local Technical Service Center for particular part number and ordering information (see *Technical Support on page 28*). You can also view the latest part number and ordering information on the SEL website at [selinc.com](http://selinc.com).

## Specifications

**Note:** TiDL (EtherCAT) technology is no longer offered in the SEL-487B-1. TiDL (T-Protocol) is available in the SEL-487B-2. If the relay is using TiDL (EtherCAT), the operating times will be delayed by 1.5 ms. Use caution when setting the relay coordination times to account for this added delay. Element operate times will also have this small added delay.

### Compliance

Designed and manufactured under an ISO 9001 certified quality management system

#### FCC Compliance Statement

This equipment has been tested and found to comply with the limits for a Class A digital device, pursuant to part 15 of the FCC Rules. These limits are designed to provide reasonable protection against harmful interference when the equipment is operated in a commercial environment. This equipment generates, uses, and can radiate radio frequency energy and, if not installed and used in accordance with the instruction manual, may cause harmful interference in which case the user will be required to correct the interference at his own expense.

UL Listed to U.S. and Canadian safety standards (File E212775; NRGU, NRGU7)

CE Mark

### General

#### AC Current Inputs (Secondary Circuits)

**Note:** Current transformers are Measurement Category II.

Current Rating (With DC Offset at X/R = 10, 1.5 Cycles)

1 A Nominal:	18.2 A
5 A Nominal:	91 A

#### Continuous Thermal Rating

1 A Nominal:	3 A 4 A (+55°C)
5 A Nominal:	15 A 20 A (+55°C)

#### Saturation Current (Linear) Rating

1 A Nominal:	20 A
5 A Nominal:	100 A

#### A/D Current Limit

**Note:** Signal clipping may occur beyond this limit.

1 A Nominal:	49.5 A
5 A Nominal:	247.5 A

#### One-Second Thermal Rating

1 A Nominal:	100 A
5 A Nominal:	500 A

#### One-Cycle Thermal Rating (Peak)

1 A Nominal:	250 A
5 A Nominal:	1250 A

#### Burden Rating

1 A Nominal:	≤0.1 VA @ 1 A
5 A Nominal:	≤0.5 VA @ 5 A

## AC Voltage Inputs

Three-phase, four-wire (wye) connections are supported.

Rated Voltage Range:	55–250 V <sub>L-N</sub>
Operational Voltage Range:	0–300 V <sub>L-N</sub>
Ten-Second Thermal Rating:	600 Vac
Burden:	≤0.1 VA @ 125 V

## Frequency and Rotation

System Frequency:	50/60 Hz
Phase Rotation:	ABC

## Power Supply

### 24–48 Vdc

Rated Voltage:	24–48 Vdc
Operational Voltage Range:	18–60 Vdc
Vdc Input Ripple:	15% per IEC 60255-26:2013
Interruption:	20 ms at 24 Vdc, 100 ms at 48 Vdc per IEC 60255-26:2013
Burden:	<35 W

### 48–125 Vdc or 110–120 Vac

Rated Voltage:	48–125 Vdc, 110–120 Vac
Operational Voltage Range:	38–140 Vdc 85–140 Vac
Rated Frequency:	50/60 Hz
Operational Frequency Range:	30–120 Hz
Vdc Input Ripple:	15% per IEC 60255-26:2013
Interruption:	14 ms at 48 Vdc, 160 ms at 125 Vdc per IEC 60255-26:2013
Burden:	<35 W, <90 VA

### 125–250 Vdc or 110–240 Vac

Rated Voltage:	125–250 Vdc, 110–240 Vac
Operational Voltage Range:	85–300 Vdc 85–264 Vac
Rated Frequency:	50/60 Hz
Operational Frequency Range:	30–120 Hz
Vdc Input Ripple:	15% per IEC 60255-26:2013
Interruption:	46 ms at 125 Vdc, 250 ms at 250 Vdc per IEC 60255-26:2013
Burden:	<35 W, <90 VA

## Control Outputs

### Standard

Make:	30 A
Carry:	6 A continuous carry at 70°C 4 A continuous carry at 85°C
1 s Rating:	50 A
MOV Protection (Maximum Voltage):	250 Vac, 330 Vdc
Pickup/Dropout Time:	≤6 ms, resistive load
Update Rate:	1/12 cycle

Breaking Capacity (10,000 Operations) per IEC 60255-23:1994

24 Vdc	0.75 A	L/R = 40 ms
48 Vdc	0.50 A	L/R = 40 ms
125 Vdc	0.30 A	L/R = 40 ms
250 Vdc	0.20 A	L/R = 20 ms

Cyclic Capacity (10,000 Operations) per IEC 60255-23:1994

Rate: 2.5 cycles/second for 4 seconds followed by 2 minutes idle for thermal dissipation

24 Vdc	0.75 A	L/R = 40 ms
48 Vdc	0.50 A	L/R = 40 ms
125 Vdc	0.30 A	L/R = 40 ms
250 Vdc	0.20 A	L/R = 20 ms

### Hybrid (High-Current Interrupting)

Make:	30 A
Carry:	6 A continuous carry at 70°C 4 A continuous carry at 85°C
1 s Rating:	50 A
MOV Protection (Maximum Voltage):	330 Vdc
Pickup/Dropout Time:	≤6 ms, resistive load
Update Rate:	1/12 cycle

Breaking Capacity (10,000 Operations) per IEC 60255-23:1994

24 Vdc	10.0 A	L/R = 40 ms
48 Vdc	10.0 A	L/R = 40 ms
125 Vdc	10.0 A	L/R = 40 ms
250 Vdc	10.0 A	L/R = 20 ms

Cyclic Capacity (10,000 Operations) per IEC 60255-23:1994

Rate: 2.5 cycles/second for 4 seconds followed by 2 minutes idle for thermal dissipation

24 Vdc	10.0 A	L/R = 40 ms
48 Vdc	10.0 A	L/R = 40 ms
125 Vdc	10.0 A	L/R = 40 ms
250 Vdc	10.0 A	L/R = 20 ms

**Note:** Do not use hybrid control outputs to switch ac control signals. These outputs are polarity-dependent.

### High-Speed, High-Current Interrupting

Make:	30 A
Carry:	6 A continuous carry at 70°C 4 A continuous carry at 85°C
1 s Rating:	50 A
MOV Protection (Maximum Voltage):	250 Vac/330 Vdc
Pickup Time:	≤10 μs, resistive load
Dropout Time:	≤8 ms, resistive load
Update Rate:	1/12 cycle

Breaking Capacity (10,000 Operations) per IEC 60255-23:1994

24 Vdc	10.0 A	L/R = 40 ms
48 Vdc	10.0 A	L/R = 40 ms
125 Vdc	10.0 A	L/R = 40 ms
250 Vdc	10.0 A	L/R = 20 ms

Cyclic Capacity (10,000 Operations) per IEC 60255-23:1994

Rate: 2.5 cycles/second for 4 seconds, followed by 2 minutes idle for thermal dissipation

24 Vdc	10.0 A	L/R = 40 ms
48 Vdc	10.0 A	L/R = 40 ms
125 Vdc	10.0 A	L/R = 40 ms
250 Vdc	10.0 A	L/R = 20 ms

**Note:** Make rating per IEEE C37.90-2005.

**Note:** Per IEC 61810-2:2005.

**Note:** Do not use hybrid control outputs to switch ac control signals.

## Control Inputs

Main Board:	5 inputs with no shared terminals 2 inputs with shared terminals
INT4 Interface Board:	6 inputs with no shared terminals 18 inputs with shared terminals (2 groups of 9 inputs, with each group sharing one terminal)
Voltage Options:	24, 48, 110, 125, 220, 250 V

Current Drawn: <5 mA at nominal voltage  
<8 mA for 110 V option

Sampling Rate: 2 kHz

#### DC Thresholds (Dropout thresholds indicate level-sensitive option)

24 Vdc: Pickup 19.2–30.0 Vdc;  
Dropout <14.4 Vdc

48 Vdc: Pickup 38.4–60.0 Vdc;  
Dropout <28.8 Vdc

110 Vdc: Pickup 88.0–132.0 Vdc;  
Dropout <66.0 Vdc

125 Vdc: Pickup 105–150 Vdc;  
Dropout <75 Vdc

220 Vdc: Pickup 176–264 Vdc;  
Dropout <132 Vdc

250 Vdc: Pickup 200–300 Vdc;  
Dropout <150 Vdc

#### AC Thresholds (Ratings met only when recommended control input settings are used—see *Table 2.1*)

24 Vac: Pickup 16.4–30.0 Vac rms;  
Dropout <10.1 Vac rms

48 Vac: Pickup 32.8–60.0 Vac rms;  
Dropout <20.3 Vac rms

110 Vac: Pickup 75.1–132.0 Vac rms;  
Dropout <46.6 Vac rms

125 Vac: Pickup 89.6–150.0 Vac rms;  
Dropout <53.0 Vac rms

220 Vac: Pickup 150.3–264.0 Vac rms;  
Dropout <93.2 Vac rms

250 Vac: Pickup 170.6–264.0 Vac rms;  
Dropout <106 Vac rms

#### Communications Ports

EIA-232: 1 Front and 3 Rear

Serial Data Speed: 300–57600 bps

#### Communications Card Slot for Optional Ethernet Card

Ordering Options: 10/100BASE-T

Connector Type: RJ45

Ordering Option: 100BASE-FX Fiber-Optic

Connector Type: LC

Fiber Type: Multimode

Wavelength: 1300 nm

Source: LED

Min. TX Power: –19 dBm

Max. TX Power: –14 dBm

RX Sensitivity: –32 dBm

Sys. Gain: 13 dB

#### Communications Ports for Optional TiDL (EtherCAT) Interface

EtherCAT Fiber-Optic  
Ports: 8

Data Rate: Automatic

Connector Type: LC fiber

Protocols: Dedicated EtherCAT

#### Class 1 LASER/LED

Wavelength: 1300 nm

Fiber Type: Multimode

Link Budget: 11 dB

Min. TX Power: –20 dBm

Min. RX Sensitivity: –31 dBm

Fiber Size: 50–200  $\mu$ m

Approximate Range: 2 km

Data Rate: 100 Mbps

Typical Fiber  
Attenuation: –2 dB/km

#### Time Inputs

##### IRIG-B Input–Serial Port 1

Input: Demodulated IRIG-B

Rated I/O Voltage: 5 Vdc

Operating Voltage Range: 0–8 Vdc

Logic High Threshold:  $\geq 2.8$  Vdc

Logic Low Threshold:  $\leq 0.8$  Vdc

Input Impedance: 2.5 k $\Omega$

##### IRIG-B Input–BNC Connector

Input: Demodulated IRIG-B

Rated I/O Voltage: 5 Vdc

Operating Voltage Range: 0–8 Vdc

Logic High Threshold:  $\geq 2.2$  Vdc

Logic Low Threshold:  $\leq 0.8$  Vdc

Input Impedance: > 1 k $\Omega$

Dielectric Test Voltage: 0.5 kVac

##### PTP–Ethernet Port 5A, 5B

Input: IEEE 1588 PTPv2

Profiles: Default, C37.238-2011 (Power Profile),  
IEC/IEEE 61850-9-3-2016 (Power Utility  
Automation Profile)

Synchronization Accuracy:  $\pm 100$  ns @ 1-second Sync Intervals when  
communicating directly with master clock

#### IRIG Time Output

Capable of driving 300 ohm termination with <200 ns propagation delay

The IRIG time output does not support high-accuracy IRIG-B  
timekeeping.

#### Operating Temperature

–40° to +85°C (–40° to +185°F)

**Note:** LCD contrast impaired for temperatures below –20° and above +70°C.

#### Humidity

5% to 95% without condensation

#### Weight (Maximum)

4U Rack Unit (TiDL  
[EtherCAT] only): 6.4 kg (14.1 lb)

7U Rack Unit: 16.8 kg (36.9 lb)

9U Rack Unit: 20.8 kg (45.9 lb)

#### Terminal Connections

Rear Screw–Terminal Tightening Torque, #8 Ring Lug

Minimum: 1.0 Nm (9 in-lb)

Maximum: 2.0 Nm (18 in-lb)

User terminals and stranded copper wire should have a minimum  
temperature rating of 105°C. Ring terminals are recommended.

#### Wire Sizes and Insulation

Wire sizes for grounding (earthing), current, voltage, and contact  
connections are dictated by the terminal blocks and expected load  
currents. You can use the following table as a guide in selecting wire  
sizes. The grounding conductor should be as short as possible and sized  
equal to or greater than any other conductor connected to the device,  
unless otherwise required by local or national wiring regulations.



Connection Type	Min. Wire Size	Max. Wire Size
Grounding (Earthing) Connection	14 AWG (2.5 mm <sup>2</sup> )	N/A
Current Connection	16 AWG (1.5 mm <sup>2</sup> )	10 AWG (5.3 mm <sup>2</sup> )
Potential (Voltage) Connection	18 AWG (0.8 mm <sup>2</sup> )	14 AWG (2.5 mm <sup>2</sup> )
Contact I/O	18 AWG (0.8 mm <sup>2</sup> )	10 AWG (5.3 mm <sup>2</sup> )
Other Connection	18 AWG (0.8 mm <sup>2</sup> )	10 AWG (5.3 mm <sup>2</sup> )

## Type Tests

### Installation Requirements

Overvoltage Category:	2
Pollution Degree:	2

### Safety

Product Standards	IEC 60255-27:2013 IEEE C37.90-2005 21 CFR 1040.10
Dielectric Strength:	IEC 60255-27:2013, Section 10.6.4.3 2.5 kVac, 50/60 Hz for 1 min: Analog Inputs, Contact Outputs, Digital Inputs 3.6 kVdc for 1 min: Power Supply, Battery Monitors 2.2 kVdc for 1 min: IRIG-B 1.1 kVdc for 1 min: Ethernet
Impulse Withstand:	IEC 60255-27:2013, Section 10.6.4.2 IEEE C37.90-2005 Common Mode: ±1.0 kV: Ethernet ±2.5 kV: IRIG-B ±5.0 kV: All other ports Differential Mode: 0 kV: Analog Inputs, Ethernet, IRIG-B, Digital Inputs ±5.0 kV: Standard Contact Outputs, Power Supply Battery Monitors +5.0 kV: Hybrid Contact Outputs
Insulation Resistance:	IEC 60255-27:2013, Section 10.6.4.4 >100 MΩ @ 500 Vdc
Protective Bonding:	IEC 60255-27:2013, Section 10.6.4.5.2 <0.1 Ω @ 12 Vdc, 30 A for 1 min
Ingress Protection:	IEC 60529:2001 + CRGD:2003 IEC 60255-27:2013 IP30 for front and rear panel IP10 for rear terminals with installation of ring lug IP40 for front panel with installation of serial port cover IP52 for front panel with installation of dust protection accessory
Max Temperature of Parts and Materials:	IEC 60255-27:2013, Section 7.3
Flammability of Insulating Materials:	IEC 60255-27:2013, Section 7.6 Compliant

### Electromagnetic (EMC) Immunity

Product Standards:	IEC 60255-26:2013 IEC 60255-27:2013 IEEE C37.90-2005
Surge Withstand Capability (SWC):	IEC 61000-4-18:2006 + A:2010 IEEE C37.90.1-2012 Slow Damped Oscillatory, Common and Differential Mode: ±1.0 kV ±2.5 kV Fast Transient, Common and Differential Mode: ±4.0 kV

Electrostatic Discharge (ESD):	IEC 61000-4-2:2008 IEEE C37.90.3-2001 Contact: ±8 kV Air Discharge: ±15 kV
Radiated RF Immunity:	IEEE C37.90.2-2004 IEC 61000-4-3:2006 + A1:2007 + A2:2010 20 V/m (>35 V/m, 80% AM, 1 kHz) Sweep: 80 MHz to 1 GHz Spot: 80, 160, 450, 900 MHz 10 V/m (>15 V/m, 80% AM, 1 kHz) Sweep: 80 MHz to 1 GHz Sweep: 1.4 GHz to 2.7 GHz Spot: 80, 160, 380, 450, 900, 1850, 2150 MHz
Electrical Fast Transient Burst (EFTB):	IEC 61000-4-4:2012 Zone A: ±2 kV: Communication ports ±4 kV: All other ports
Surge Immunity:	IEC 61000-4-5:2005 Zone A: ±2 kV <sub>L-L</sub> ±4 kV <sub>L-E</sub> ±4 kV: communication ports (Ethernet and IRIG-B) <b>Note:</b> Cables connected to EIA-232 communications ports shall be less than 10 m in length for Zone A compliance. Zone B: ±2 kV: communication ports (except Ethernet and IRIG-B) <b>Note:</b> Cables connected to EIA-232 communications ports shall be less than 10 m in length for Zone B compliance.
Conducted Immunity:	IEC 61000-4-6:2013 20 V/m; (>35 V/m, 80% AM, 1 kHz) Sweep: 150 kHz–80 MHz Spot: 27, 68 MHz
Power Frequency Immunity (DC Inputs):	IEC 61000-4-16:2015 Zone A: Differential: 150 V <sub>RMS</sub> Common Mode: 300 V <sub>RMS</sub>
Power Frequency Magnetic Field:	IEC 61000-4-8:2009 Level 5: 100 A/m; ≥60 Seconds; 50/60 Hz 1000 A/m 1 to 3 Seconds; 50/60 Hz <b>Note:</b> 50G1P ≥0.05 (ESS = N, 1, 2) 50G1P ≥0.1 (ESS = 3, 4)
Power Supply Immunity:	IEC 61000-4-11:2004 IEC 61000-4-17:1999/A1:2001/A2:2008 IEC 61000-4-29:2000 AC Dips & Interruptions Ripple on DC Power Input DC Dips & Interruptions Gradual Shutdown/Startup (DC only) Discharge of Capacitors Slow Ramp Down/Up Reverse Polarity (DC only)
Damped Oscillatory Magnetic Field:	IEC 61000-4-10:2016 Level 5: 100 A/m

### EMC Compatibility

Product Standards:	IEC 60255-26:2013
Emissions:	IEC 60255-26:2013, Section 7.1 Class A 47 CFR Part 15B Class A Canada ICES-001 (A) / NMB-001 (A)

## Environmental

Product Standards:	IEC 60255-27:2013
Cold, Operational:	IEC 60068-2-1:2007 Test Ad: 16 hours at $-40^{\circ}\text{C}$
Cold, Storage:	IEC 60068-2-1:2007 Test Ad: 16 hours at $-40^{\circ}\text{C}$
Dry Heat, Operational:	IEC 60068-2-2:2007 Test Bd: 16 hours at $+85^{\circ}\text{C}$
Dry Heat, Storage:	IEC 60068-2-2:2007 Test Bd: 16 hours at $+85^{\circ}\text{C}$
Damp Heat, Cyclic:	IEC 60068-2-30:2005 Test Db: $+25^{\circ}\text{C}$ to $+55^{\circ}\text{C}$ , 6 cycles (12 + 12-hour cycle), 95% RH
Damp Heat, Steady State:	IEC 60068-2-78:2013 Severity: 93% RH, $+40^{\circ}\text{C}$ , 10 days
Cyclic Temperature:	IEC 60068-2-14:2009 Test Nb: $-40^{\circ}\text{C}$ to $+80^{\circ}\text{C}$ , 5 cycles
Vibration Resistance:	IEC 60255-21-1:1988 Class 2 Endurance, Class 2 Response
Shock Resistance:	IEC 60255-21-2:1988 Class 1 Shock Withstand, Class 1 Bump Withstand, Class 2 Shock Response
Seismic:	IEC 60255-21-3:1993 Class 2 Quake Response

## Reporting Functions

### High-Resolution Data

Rate:	8000 samples/second 4000 samples/second 2000 samples/second 1000 samples/second
Output Format:	Binary COMTRADE

**Note:** Per IEEE C37.111-1999 and -2013, *IEEE Standard Common Format for Transient Data Exchange (COMTRADE) for Power Systems*.

### Event Reports

Length:	0.25–24 seconds (depending on LER setting)
Resolution:	4 and 12 samples/cycle
Volatile Memory:	3 seconds of back-to-back event reports sampled at 8 kHz
Nonvolatile Memory:	At least 4 event reports of a 3-second duration sampled at 8 kHz

### Oscillography

Volatile Memory:	3 seconds of back-to-back event reports sampled at 8 kHz
Nonvolatile Memory:	At least 5 event reports of a 3-second duration sampled at 8 kHz

### Event Summary

Storage:	100 summaries
----------	---------------

### Sequential Events Recorder

Storage:	1000 entries
Trigger Elements:	250 relay elements
Resolution:	0.5 ms for contact inputs
Resolution:	1/12 cycle for all elements

## Processing Specifications

### AC Voltage and Current Inputs

12 samples per cycle, 3 dB low-pass analog filter cut-off frequency of 646 Hz,  $\pm 5\%$

### Digital Filtering

Full-cycle cosine after low-pass analog filtering

## Protection and Control Processing

12 times per power system cycle

### Control Points

96 remote bits  
64 local control bits  
32 latch bits in protection logic  
32 latch bits in automation logic

## Relay Element Pickup Ranges and Accuracies

### Differential Elements

Number of Zones:	6
Number of Check Zones:	3
Number of Terminals:	
Three-Relay Application:	21
Single-Relay Application:	7
Pickup Range:	0.10–4.00 pu
Pickup Accuracy:	1 A nominal: $\pm 5\% \pm 0.02$ A 5 A nominal: $\pm 5\% \pm 0.10$ A
Slope 1	
Setting Range:	15%–90%
Slope 2	
Setting Range:	50%–90%

### Supervising Differential Element

Quantity:	9 total, 1 per zone (6 standard zones, 3 check zones)
Setting Range:	0.05–3.00 pu
Accuracy:	$\pm 5\% \pm 0.02 \cdot I_{\text{NOM}}$

### Incremental Restraint and Operating Threshold Current Supervision

Setting Range:	0.1–10.0 pu
Accuracy:	$\pm 5\% \pm 0.02 \cdot I_{\text{NOM}}$

### Sensitive Differential Current Alarm

Quantity:	9 total, 1 per zone (6 standard zones, 3 check zones)
Setting Range:	0.05–1.00 pu
Accuracy:	$\pm 5\% \pm 0.02 \cdot I_{\text{NOM}}$
Timer Setting Range:	50–6000 cycles

### Instantaneous/Definite-Time Overcurrent Elements

Phase Current Setting Range	
5 A Model:	OFF, 0.25–100.00 A secondary, 0.01 A steps
1 A Model:	OFF, 0.05–20.00 A secondary, 0.01 A steps
Accuracy (Steady State)	
5 A Model:	$\pm 0.05$ A, $\pm 3\%$ of setting
1 A Model:	$\pm 0.01$ A, $\pm 3\%$ of setting
Transient Overreach:	$< 5\%$ of setting
Timer Setting Range:	0.00–99999.00 cycles, 1/6-cycle steps
Timer Accuracy:	$\pm 0.1\%$ of settings $\pm 1/6$ cycle
Maximum Operating Time:	1.5 cycles

### Time-Overcurrent Elements

Pickup Range	
5 A Model:	0.25–16.00 A secondary, 0.01 A steps
1 A Model:	0.05–3.20 A secondary, 0.01 A steps
Accuracy (Steady State)	
5 A Model:	$\pm 0.05$ A, $\pm 3\%$ of setting
1 A Model:	$\pm 0.01$ A, $\pm 3\%$ of setting

Time Dial Range	
US:	0.50–15.00, 0.01 steps
IEC:	0.05–1.00, 0.01 steps
Curve Timing Accuracy:	±1.50 cycles, ±4% of curve time (for current between 2 and 30 multiples of pickup)
Reset:	1 power cycle or Electromechanical Reset Emulation time

### Under- and Overvoltage Elements (27, 59)

Processing Rate:	1/6 cycle
Phase Under- and Overvoltage (2 Level/Phase)	
Setting Range:	2.00–300 $V_{L-N}$ in 0.01 steps
Accuracy:	±3% of setting, ±0.5 V
Transient Overreach:	<5% of pickup
Maximum Delay:	1.5 cycles

Zero- and Negative-Sequence Overvoltage Elements	
Setting Range:	2.00–300 $V_{L-N}$ in 0.01 steps
Accuracy:	±5% of setting, ±1 V
Transient Overreach:	<5% of setting
Maximum Delay:	1.5 cycles

### Breaker Failure Instantaneous Overcurrent

Setting Range	
5 A Model:	0.50–50 A, 0.01 A steps
1 A Model:	0.10–10.0 A, 0.01 A steps
Accuracy	
5 A Model:	±0.05 A, ±3% of setting
1 A Model:	±0.01 A, ±3% of setting
Transient Overreach:	<5% of setting
Maximum Pickup Time:	1.5 cycles
Maximum Reset Time:	<1 cycle
Timers Setting Range:	0–6000 cycles, 1/12-cycle steps (BFPUnn, RTPUnn) 0–1000 cycles, 1/12-cycle steps (BFISPnn, BFIDOnn)
Time Delay Accuracy:	1/12 cycle, ±0.1% of setting

### Disconnect Monitor

Number:	60
Timer Setting Range:	0–99999 cycles, 1 cycle step

### Breaker Status

Number:	21
---------	----

### Coupler Security Logic

Number:	4
Timer Setting Range:	0–1000 cycles, 1/12 cycle step

### Control Input Timers

Setting Range	
Pickup:	0.00–30 ms
Dropout:	0.00–30 ms

Input Sampling Rate:	2 kHz
Processing Rate:	1/6 cycle
Operating Time:	≤1.5 seconds (element DC1R) ≤1.5 cycles (all elements but DC1R)

Setting Range	
DC Settings:	1 Vdc Steps (OFF, 15–300 Vdc)
AC Ripple Setting:	1 Vac Steps (1–300 Vac)
Pickup Accuracy:	±10% ±2 Vdc (DC1RP) ±3% ±2 Vdc (all elements but DC1RP)

## Metering Accuracy

All metering accuracies are based on an ambient temperature of 20°C and nominal frequency.

### Currents

#### Phase Current Magnitude

5 A Model:	±0.2% plus ±4 mA (2.5–15 A sec)
1 A Model:	±0.2% plus ±0.8 mA (0.5–3.0 A sec)

#### Phase Current Angle

All Models:	±0.2° in the current range (0.5–3.0) • $I_{NOM}$
-------------	---

#### Differential Currents per Zone (Steady State)

IOP, IRT:	±5.0% ± 0.02 • $I_{NOM}$
IOPCZ, IRTCA:	±5.0% ± 0.02 • $I_{NOM}$

### Voltages

#### Phase Voltage Magnitude

300 V Maximum Inputs:	±2.5% ± 1 V (5–33.5 V) ±0.1% (33.5–300 V)
-----------------------	--

#### Phase Angle

300 V Maximum Inputs:	±1.0° (5–33.5 V) ±0.5° (33.5–300 V)
-----------------------	--

## Station DC Battery System Monitor Specifications

Rated Voltage:	24–250 Vdc
Operational Voltage Range:	0–350 Vdc

# Technical Support

---

We appreciate your interest in SEL products and services. If you have questions or comments, please contact us at:

Schweitzer Engineering Laboratories, Inc.  
2350 NE Hopkins Court  
Pullman, WA 99163-5603 U.S.A.  
Tel: +1.509.338.3838  
Fax: +1.509.332.7990  
Internet: [selinc.com/support](http://selinc.com/support)  
Email: [info@selinc.com](mailto:info@selinc.com)

---

© 2012-2025 by Schweitzer Engineering Laboratories, Inc.

Content subject to change without notice.

Unless otherwise agreed in writing, all SEL product sales are subject to SEL's terms and conditions located here: <https://selinc.com/company/termsandconditions/>.

EtherCAT® is registered trademark and patented technology, licensed by Beckhoff Automation GmbH, Germany

## SCHWEITZER ENGINEERING LABORATORIES, INC.

2350 NE Hopkins Court • Pullman, WA 99163-5603 U.S.A.

Tel: +1.509.332.1890 • Fax: +1.509.332.7990

[selinc.com](http://selinc.com) • [info@selinc.com](mailto:info@selinc.com)

