

# SEL SEL-587Z High-Impedance Differential Relay

## Bus or Transformer Protection



The SEL-587Z Relay is a flexible high-impedance differential relay that combines time-proven high-impedance analog technology with the advantages of microprocessor technology. Designed primarily as high-impedance bus protection, the relay is also suitable for restricted earth fault applications on transformers with grounded-wye windings. Use the independent overcurrent elements to complement the high-impedance differential elements.

## Major Features and Benefits

- **Protection.** Use high-impedance differential elements for fast tripping for in-zone faults, while providing security during heavy through faults and CT saturation. Use familiar high-impedance equations to calculate the voltage-based differential element settings. Save time, money, and panel space because the relay includes the resistors and MOVs required for high-impedance differential protection.
- **Reporting, Monitoring, and Metering.** Simplify fault analysis with event reports and the Sequential Events Recorder. Use a low-set voltage differential element as a CT open-circuit detection function. Validate CT connections by using the metered voltage differential quantities. Interrogate the relay for instantaneous measurements of phase and demand current in transformer applications.
- **Automation, Integration, and Communications.** Use the front- and rear-panel communications ports for system integration, relay settings, and event report retrieval. Modbus RTU, SEL ASCII, and SEL Fast Message protocols are included as standard features of the relay. Use front-panel pushbuttons to save the expense of separately mounted control switches. Use serial port communications for remote control of circuit breakers or other programmable functions.
- **Relay and Logic Settings Software.** ACSELERATOR QuickSet<sup>®</sup> SEL-5030 Software reduces engineering costs for relay settings and logic programming. The built-in HMI and Control screens provide intuitive displays that help support commissioning and troubleshooting.

# Functional Overview

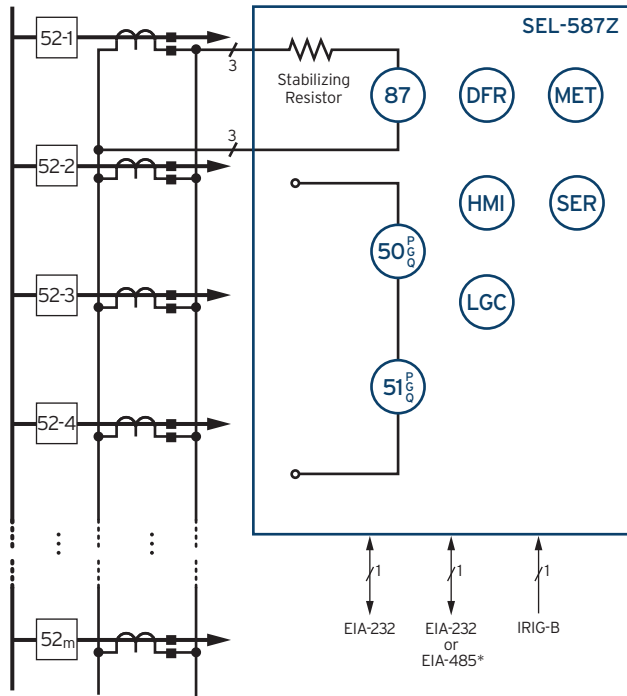


Figure 1 Functional Diagram

### ANSI NUMBERS/ACRONYMS AND FUNCTIONS

50 (P, G, Q)	Overcurrent (Phase, Ground, Neg. Seq.)
51 (P, G, Q)	Time-Overcurrent (Phase, Ground, Neg. Seq.)
87	Three-Phase High-Impedance Differential Elements
DFR	Event Reports
LGC	SELogiC Control Equations
HMI	Operator Interface
MET	High-Accuracy Metering
SER	Sequential Events Recorder

\* Optional Feature

# Protection

## Differential Protection

Differential protection is one of the most economical and reliable protection principles available for buses, transformers, and reactors. CT saturation is the most critical design consideration.

Figure 2 shows a through fault, with the direction of current flow in Feeders 1–4 towards the busbar. The sum of the fault current from Feeders 1–4 flows through the CT on Feeder 5, which can result in CT5 saturating.

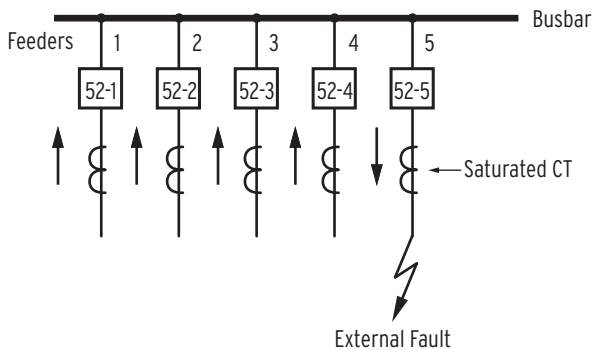


Figure 2 CT Saturation Resulting From a Through Fault

High-impedance differential protection offers immunity against relay misoperation resulting from CT saturation, provided the stabilizing resistor in the circuit has a sufficiently high value. To comply with this requirement, the SEL-587Z uses 2000-ohm resistors, large enough to provide security against CT saturation for through faults. Figure 3 shows typical connections of the lockout contact (86), differential element (87Z), and MOV.

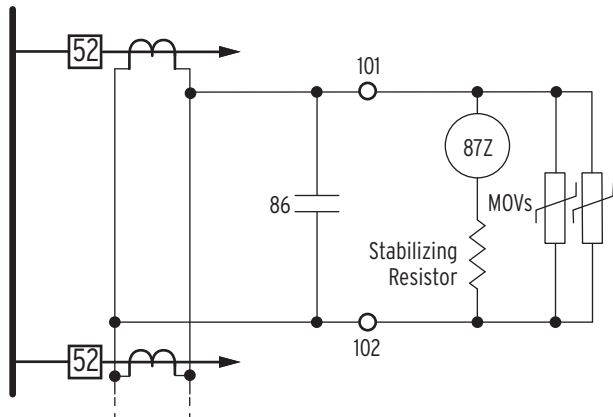
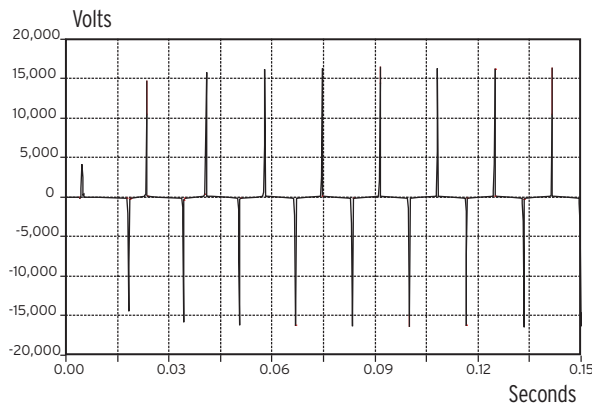
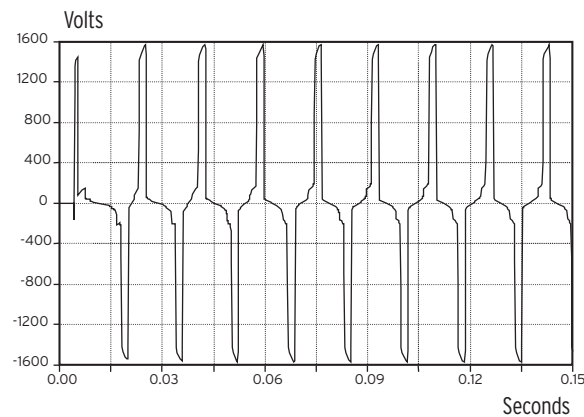


Figure 3 Typical Circuit Connection for High-Impedance Differential Protection

During bus faults, the voltage across the stabilizing resistor can rise to very high values if not limited, as illustrated in *Figure 4*.



**Figure 4 Voltage Without MOV Clamping**



**Figure 5 Voltage With MOV Clamping**

*Figure 5* shows the resultant voltage with a metal oxide varistor (MOV) connected in parallel with the high-impedance elements, clamping the secondary peak voltage to less than 2 kV. The 2000-ohm resistors, combined with suitable MOVs, form the high-impedance input circuit of each phase. For the best performance, select current transformers with fully distributed windings and identical ratio and saturation characteristics.

## Bus Protection

Designing bus protection means, as with all protection systems, finding a balance between security and dependability. In a single-zone application, the busbar is the common connection point of all the feeders in the substation. Incorrect bus protection operation affects all the feeders connected to that zone that, at smaller substations, affects each and every customer. Failure of bus protection to operate affects even more customers, because remote protection at adjacent stations must now clear the fault. In addition, high-impedance transformer

grounding practices limit the ground-fault current, necessitating sensitive, phase-segregated protection elements. However, while the ground-fault current is limited, the phase-to-phase current can still be very high, which could result in CT saturation for through faults. The SEL-587Z has three sensitive, independent high-impedance elements, each with two setting levels, providing fast and reliable differential protection.

## Transformer Protection

The three independent high-impedance elements are ideal for sensitive restricted earth fault protection on transformers with grounded-wye windings. If both HV and LV windings are wye-connected and grounded, use two high-impedance elements, one on each side of the transformer. Restricted earth fault (REF) protection is not affected by unbalanced load and very seldom by CT saturation for through faults. Although very sensitive, restricted earth fault protection protects only against phase-to-ground faults. To protect against phase-to-phase faults and external phase-to-ground bushing faults, combine the high-impedance elements with instantaneous and time-overcurrent elements. For complete transformer protection that includes percentage differential elements, use the SEL-587 Relay or the SEL-387 Relay with the SEL-587Z.

## Overcurrent Protection

The SEL-587Z features overcurrent elements that include maximum-phase, two levels of phase-specific elements, and two levels of negative-sequence and residual overcurrent elements. The relay has six time-overcurrent elements: a maximum-phase element, three phase-specific elements, a negative-sequence element, and a residual element. The overcurrent and high-impedance differential elements are independent and can protect separate equipment.

When you use the SEL-587Z for transformer protection, the instantaneous overcurrent elements provide phase and ground overcurrent protection for bushing faults, while the time-overcurrent elements provide phase and ground protection for coordination with other system protection.

**Table 1 Overcurrent Elements Available in the SEL-587Z**

Element	Instantaneous	Time-Overcurrent
Maximum-phase	3	1
Phase-specific	6	3
Negative-sequence	2	1
Zero-sequence	2	1

**Table 2 Inverse Time-Overcurrent Curves Available in the SEL-587Z**

US	IEC
Moderately Inverse (U1)	Standard Inverse (C1)
Inverse (U2)	Very Inverse (C2)
Very Inverse (U3)	Extremely Inverse (C3)
Extremely Inverse (U4)	Long-Time Inverse (C4)
Short-Time Inverse (U5)	Short-Time Inverse (C5)

## Reporting, Monitoring, and Metering

Event report and Sequential Event Report (SER) features simplify post-fault analysis and improve understanding of simple and complex protection scheme operations. These features also aid in testing and troubleshooting relay settings and protection schemes.

### Event Reports

In response to a programmable trigger, the present element status information is recorded in each event report, confirming relay, scheme, and system performance for every fault. A total of 10 events are stored in nonvolatile memory. Decide how much detail you want when you request an event report. You can choose to display a standard event report with 15 cycles of the analog high-impedance differential elements and overcurrent elements, selected Relay Word bits, the inputs and outputs, and the relay settings at 1/4-cycle or 1/8-cycle data resolution.

Use event report information in conjunction with the SEL-5601-2 SYNCHROWAVE<sup>®</sup> Event Software to produce oscillographic type reports suitable for inclusion in analysis documents and reports.

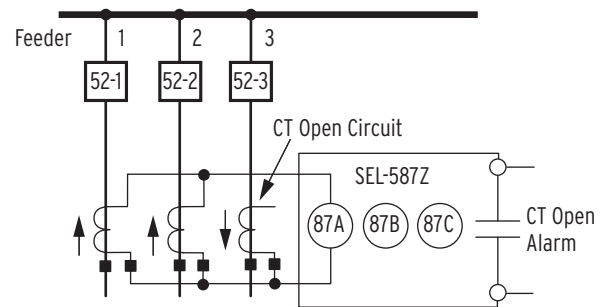
### Sequential Events Recorder (SER)

The relay SER stores the latest 512 entries in nonvolatile memory. Use this feature to gain a broad perspective of relay element operation. Events that trigger an SER entry include: input/output change of state and element pickup/dropout. Each entry includes the date, time, differential and current magnitudes, and logic variables. On each processing interval, the relay examines the Relay Word for changes of state in any of the Relay Word elements declared in the SER1, SER2, and SER3 settings. Upon detecting a change of state, the relay adds a row to the SER report. The relay stores the SER report in nonvolatile memory to retain information if a power failure occurs before you can examine the events.

Table 2 lists the time-overcurrent curves available in the relay. Each curve has two choices for the reset characteristic. One choice resets the elements if the current drops below pickup for at least one cycle. The other choice causes the relay to emulate the reset characteristic of an electromechanical induction disk relay.

### Monitoring

The high-impedance element has two setting levels. By the nature of the high-impedance application, the relay measures only the out-of-balance quantity of the parallel-connected CTs. Detect an open-circuit CT by setting one level to a low value as compared to an out-of-zone fault, and direct the output to an alarm function, as shown in Figure 6. For example, to detect a 40 mA secondary current, set the element to  $0.04 \cdot 2000 = 80$  V. Other relay monitoring includes self-tests to continuously track crucial relay subsystems such as RAM, critical RAM, ROM, and EEPROM tests.

**Figure 6 Detecting an Open CT (A-Phase)**

### Metering

The SEL-587Z provides three types of metering functions typically used in transformer protection schemes as illustrated in Figure 14. The metering functions are: instantaneous, demand, and peak demand. Metered quantities shown in Table 3 include differential voltages, negative-sequence currents, and zero-sequence (residual) currents.

Use the meter function to detect incorrect CT wiring during testing and installation. Figure 7 is an example of the metering output for the case shown in Figure 6. Differential elements 87B and 87C have values close to zero, but the A element has a value of 73 volts, indicating incorrect CT polarity, ratio, or wiring.

**Table 3 Metering Capabilities**

Quantities	Description
Voltages 87A, 87B, 87C	Voltage from each differential element
Currents IA, IB, IC, IG (3I <sub>0</sub> ), 3I <sub>2</sub>	Magnitudes and angles for each phase and sequence current
Demand Current IA, IB, IC, IG (3I <sub>0</sub> ), 3I <sub>2</sub>	Magnitudes of each phase and sequence current
Peak demand IA, IB, IC, IG (3I <sub>0</sub> ), 3I <sub>2</sub>	Magnitudes of each phase and sequence current

```

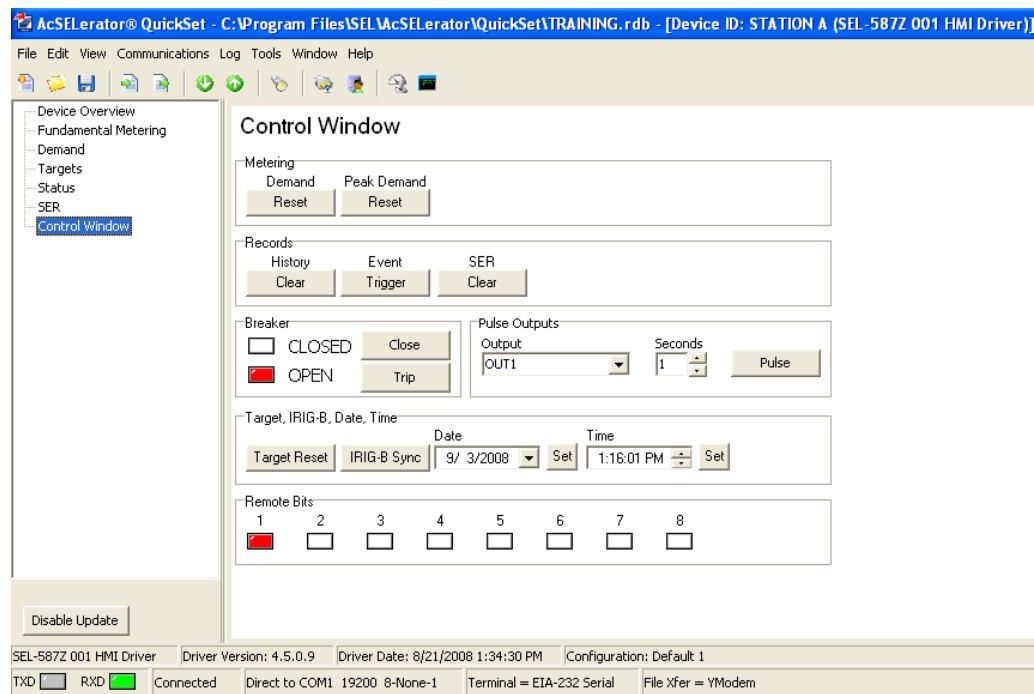
>> MET <Enter>
North Busbar      Date: 04/14/01      Time: 17:36:02:616
Apollo Station
      87A      87B      87C
V MAG (V)      73      0.5      0.2
      1A      1B      1C      1G      3I2
I MAG (A)      0.1      0.0      0.0      0.01      0.01
I ANG (DEG)    0.01     -119.23   121.12   0.11     0.10

```

**Figure 7 METER Report for an Open CT (A-Phase)**

## Relay and Logic Settings Software

QuickSet uses the Microsoft Windows operating system to simplify settings and provide analysis support for the SEL-587Z. One can, for instance, open an QuickSet Control screen for intuitive control functions similar to those shown in *Figure 8*.

**Figure 8 QuickSet Screen Showing SEL-587Z Control Functions**

Use QuickSet to create and manage relay settings:

- Develop settings offline with an intelligent settings editor that only allows valid settings
- Use online help to assist with configuration of proper settings
- Organize settings with the relay database manager
- Load and retrieve settings through use of a simple PC communications link

Use QuickSet to verify settings and analyze events:

- Analyze power system events with integrated waveform and harmonic analysis tools

Use QuickSet to aid with monitoring, commissioning, and testing the SEL-587Z:

- Use the HMI to monitor current and voltage information during testing
- Use the PC interface to remotely obtain power system data
- Control local and remote bits from the QuickSet control window
- View the status of all Relay Word bits at once in the Targets display window

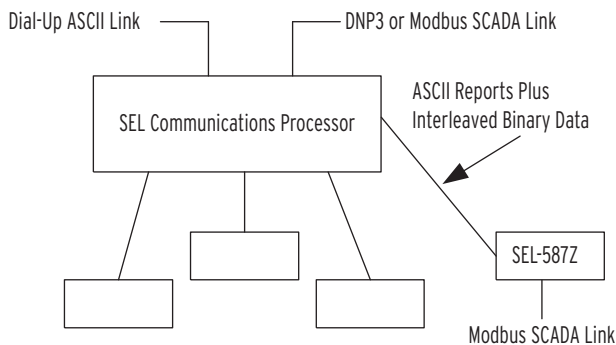
# Automation, Integration, and Communication

**Table 4 Communications Protocols**

Type	Description
Simple ASCII	Plain language commands for human and simple machine communication. Use for metering, setting, self-test status, event reporting, and other functions.
Compressed ASCII	Comma-delimited ASCII data reports. Allows external devices to obtain relay data in an appropriate format for direct import into spreadsheets and database programs. Data are checksum protected.
Extended Fast Meter and Fast Operate	Binary protocol for machine-to-machine communication. Quickly updates SEL-2032/SEL-2030/SEL-2020 Communications Processors, RTUs, and other substation devices with metering information, relay element, I/O status, time-tags, open and close commands, and summary event reports. Data are checksum protected. Binary and ASCII protocols operate simultaneously over the same communications lines to prevent loss of control operator metering information while a technician is transferring an event report.
Distributed Port Switch Protocol	Enables multiple SEL devices to share a common communications bus (two-character address setting range is 01–99). Use this protocol for low-cost, port-switching applications.
Modbus RTU	Use this protocol to communicate with PLC, HMI, and SCADA systems.

## Serial Communication

The SEL-587Z has two independently operated EIA-232 ports: one on the front and a ground-isolated port on the rear of the relay. The rear port can be an EIA-485 port but must be so specified at ordering. The relay needs no special communications software. Use any system that emulates a standard terminal system. Establish communication by connecting computers, modems, protocol converters, printers, an SEL-2032, SEL-2030, or SEL-2020 Communications Processor, SCADA serial port, and/or RTU for local or remote communication. See *Table 4* for a list of available communications protocols.



**Figure 9 Example Communications System**

SEL communications processors often form hubs of star networks, with point-to-point fiber or copper connection between the hub and the SEL-587Z. The communications processor supports external communications links including the public switched

telephone network for engineering access to dial-out alerts and private line connections to your SCADA system.

## IRIG-B

The demodulated IRIG-B time-code input synchronizes the SEL-587Z time to within  $\pm 5$  ms of the time-source input. SEL-2032, SEL-2030, or SEL-2020 Communications Processors provide convenient sources for this time code.

SEL manufactures a variety of standard cables for connecting this and other relays to a variety of external devices. Contact your SEL representative for more information on cable availability.

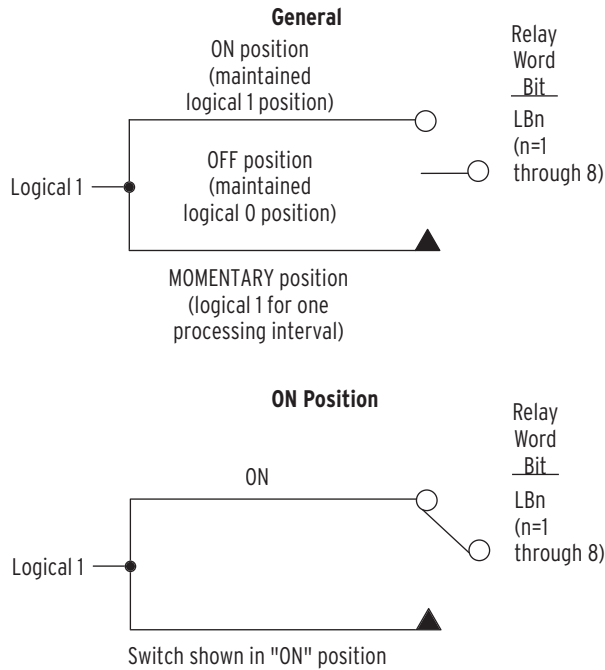
## Control Logic and Integration

Use built-in control logic and integration features in the SEL-587Z to economically combine common substation operations. This includes eliminating wiring and replacing traditional panel switches and indicators.

## Replace Traditional Panel Control Switches

Eliminate traditional panel control switches with eight local control switches. Set, clear, or pulse local control switches with the front-panel pushbuttons and display. Program the local control switches into your control scheme via SELOGIC<sup>®</sup> control equations. Use the local control switches to perform functions such as a trip test or a breaker trip/close. *Figure 10* shows that you can configure local control switches for ON, OFF, and MOMENTARY functions.





**Figure 10 Local Control Switches**

### Eliminate RTU-to-Relay Wiring

Eliminate RTU-to-relay wiring with eight remote control switches. Set, clear, or pulse remote control switches via serial port commands. Program the remote control switches into your control scheme via SELOGIC control equations. Use remote control switches for SCADA-type control operations such as trip, close, and settings group selection. Switch operations are identical as for local switches.

### Replace Traditional Indicating Panel Lights

Replace traditional indicating panel lights with eight programmable displays. Define custom messages (e.g., Breaker Open, Breaker Closed) to report power system or relay conditions on the front-panel display.

## SELogic Control Equations

USE SELOGIC control equations to assign relay outputs to any logical combination of relay elements or inputs.

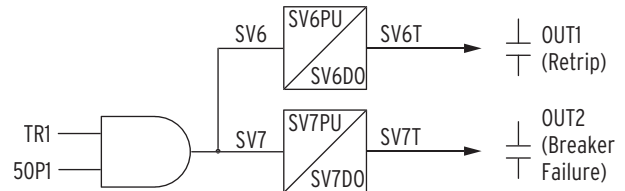
Program SELOGIC control equations by combining relay elements, inputs, and outputs with SELOGIC control equation operators. The state of all logical elements in the relay is reflected by bits from a “Relay Word” table. These logical elements include all current (50/51) and level-detecting elements, timer elements, SELOGIC control equation variables, inputs, outputs, and remote and local bits. You can use any element including input/output, differential, and overcurrent variables in these equations.

SELOGIC control equation operators include OR, AND, invert, and parentheses.

The basic building blocks of SELOGIC control equations are the Relay Word bits. The Relay Word bits are simple digital quantities having a value of either logical 0 or logical 1. The terms “assert” or “asserted” refer to a Relay Word bit that has a value of logical 1 or is changing from logical 0 to logical 1. The terms “deassert” or “deasserted” refer to a Relay Word bit that has a value of logical 0 or is changing from logical 1 to logical 0. Various relay elements assert or deassert Relay Word bits, which the relay uses in fixed internal logic to make decisions, interpret inputs, or drive outputs. You can access these same bits to flexibly define inputs or outputs, specify control variables for internal logic, or create special customized logic by using SELOGIC control equations.

In addition to Boolean logic, ten general purpose SELOGIC control equation timers eliminate external timers for custom protection or control schemes. Each timer has independent time-delay pickup and dropout settings. Program each timer input with any desired element (e.g., time qualify a current element). Assign the timer output to trip logic, event report triggering, or other control scheme logic.

Figure 11 depicts an example breaker failure circuit, configured with relay elements and stored in nonvolatile memory.



**Figure 11 Dedicated Breaker Fail Scheme Created With SELogic Control Equation Variables/Timers**

The following four lines show the SELOGIC control equations to create the breaker fail circuit:

- SV6 = 50P1\*TR1
- SV7 = 50P1\*TR1
- OUT1 = SV6T (retrip)
- OUT2 = SV7T (breaker failure trip)

## Additional Features

### Front-Panel Display

The LCD shows event, metering, setting, and relay self-test status information. Use the eight multifunction push-buttons to control this display, showing the messages the relay generates and programmable Display Points. The default display scrolls through any active, nonblank Display Points. Each display remains for two seconds, before scrolling continues. Any message the relay generates because of an alarm condition takes precedence over

the normal default display. Error messages such as a self-test failure appear on the LCD in place of the default display. The {EXIT} pushbutton returns the display to the default display when the relay is displaying some other front-panel function.

When the relay turns on, the LCD scrolls through the current and voltage element displays until the relay is again enabled. When the EN LED indicates the relay is enabled, the LCD scrolls through active Display Points and metering screens.

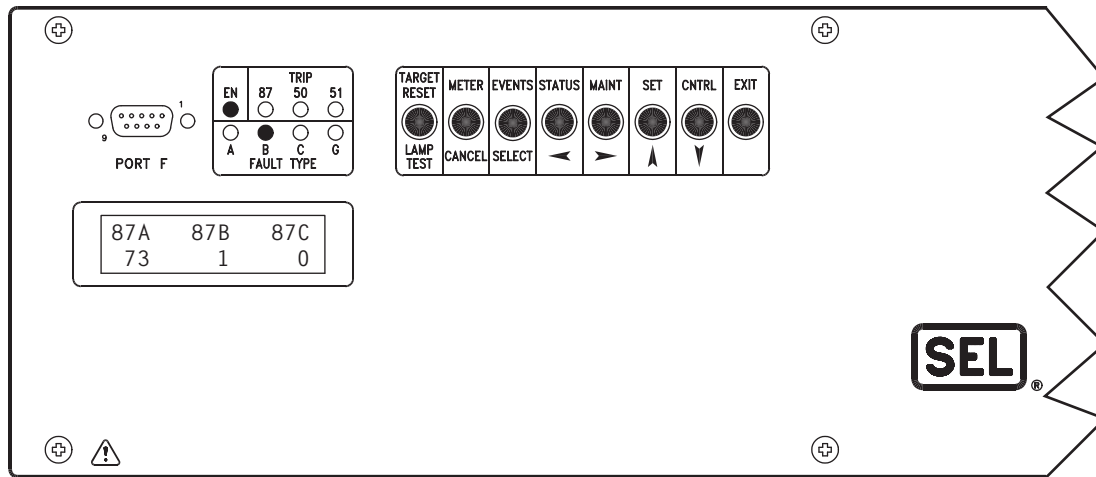


Figure 12 Front-Panel Display

## Status and Trip Target LEDs

The SEL-587Z includes eight status and trip target LEDs on the front panel. These targets are shown in Figure 12 and explained in Table 5. The target LEDs indicate conditions that the relay has detected on the power system and how the relay has reacted. Nonvolatile memory stores the states of all eight LEDs. If the relay loses power, the targets will resume their last state when power returns.

Use the SEL ASCII **TAR *n*** command (*n* = row number) to assign relay variables to the LEDs during testing. This provides a visual indication of the status of more than 100 variables in the relay. Local Bit (LB) variables, the equivalent of panel switches, are stored in Row 7 in the relay. For example, assume LB1 and LB6 are asserted. Entering **TAR 7** results in the LED display shown in Figure 12.

Table 5 Description of Target LEDs

Target LED	Function
EN	Relay powered up properly, self-tests okay
87	Either Level 1 or Level 2 of the three differential elements asserted
50	Any one of the 13 instantaneous overcurrent elements asserted
51	Any one of the six time-overcurrent elements asserted
A	A-phase overcurrent, time-overcurrent, or differential asserted
B	B-phase overcurrent, time-overcurrent, or differential asserted
C	C-phase overcurrent, time-overcurrent, or differential asserted
G	Any of the three ground elements asserted

## Application Examples

### Bus Protection

Figure 13 illustrates a typical single-zone, high-impedance bus protection installation. The CTs must have identical ratios and saturation characteristics (C-ratings). Configure the second level of the high-impedance element to an alarm function with a low setting to report on CT open-circuit conditions. Advance warning of an open-circuit CT gives maintenance personnel time to take corrective action that may prevent severe damage to the CT and nearby primary equipment.

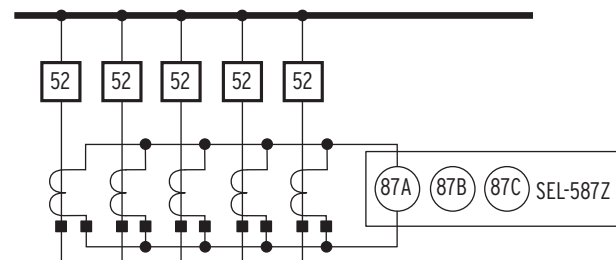


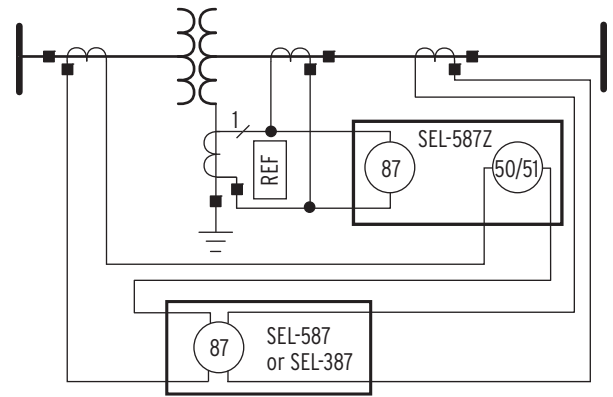
Figure 13 Example Bus Protection (One Phase Shown Connected)



# Transformer Protection

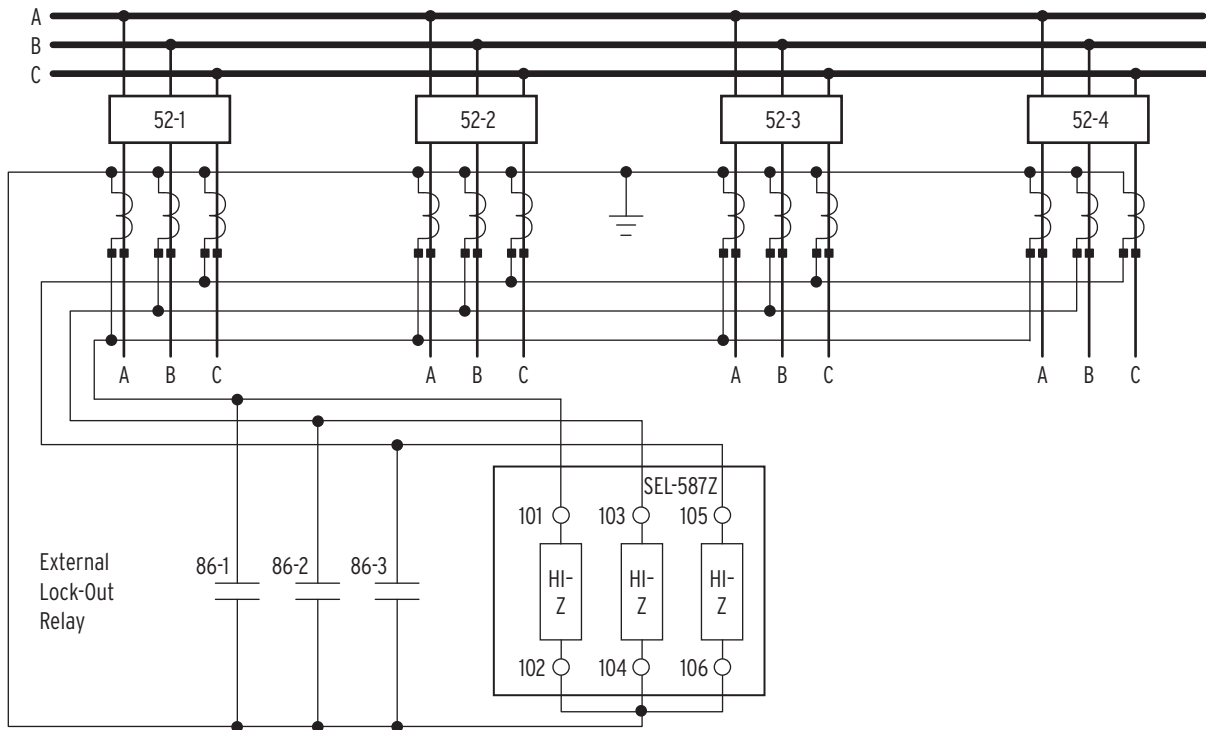
Combine the overcurrent elements with the high-impedance differential elements to provide protection for smaller, wye-connected and grounded transformers; see *Figure 14*. The REF CTs must have identical ratios and saturation characteristics.

When you use the SEL-587Z for transformer protection, use the overcurrent elements to provide instantaneous phase and ground overcurrent protection for bushing faults. These elements provide phase and ground time-overcurrent protection for coordination with other system protection.

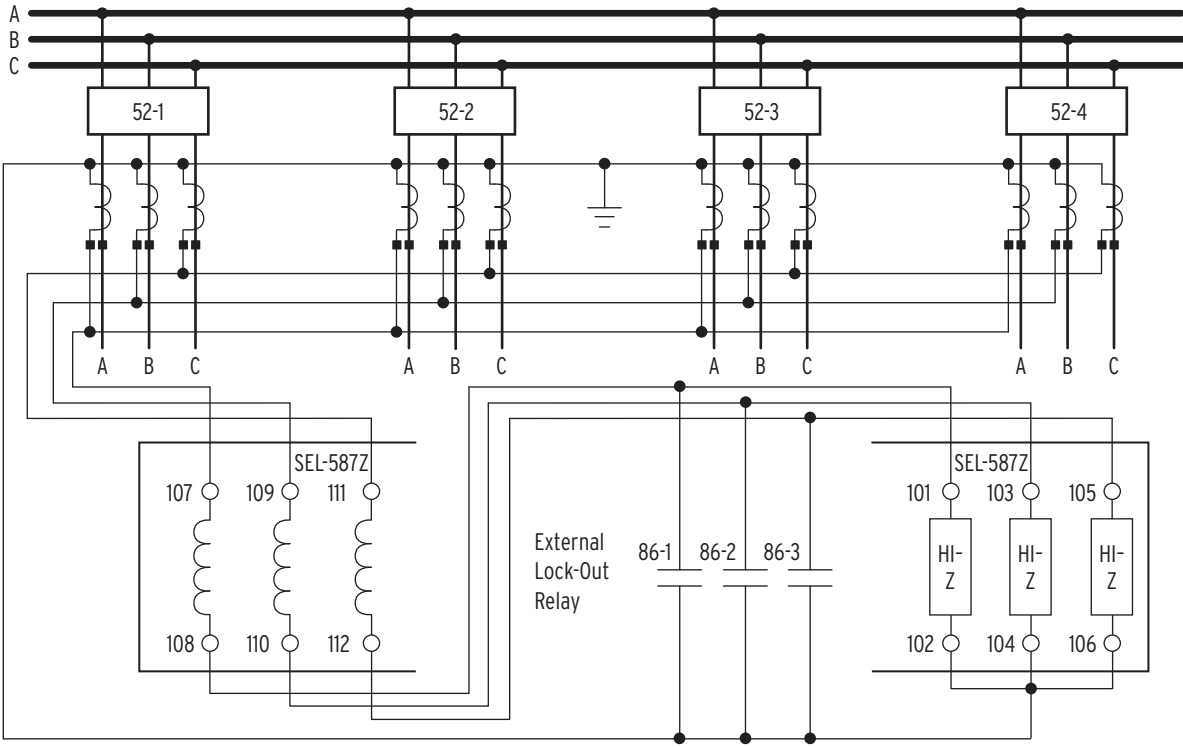


**Figure 14** Transformer With Grounded-Wye Connected Winding

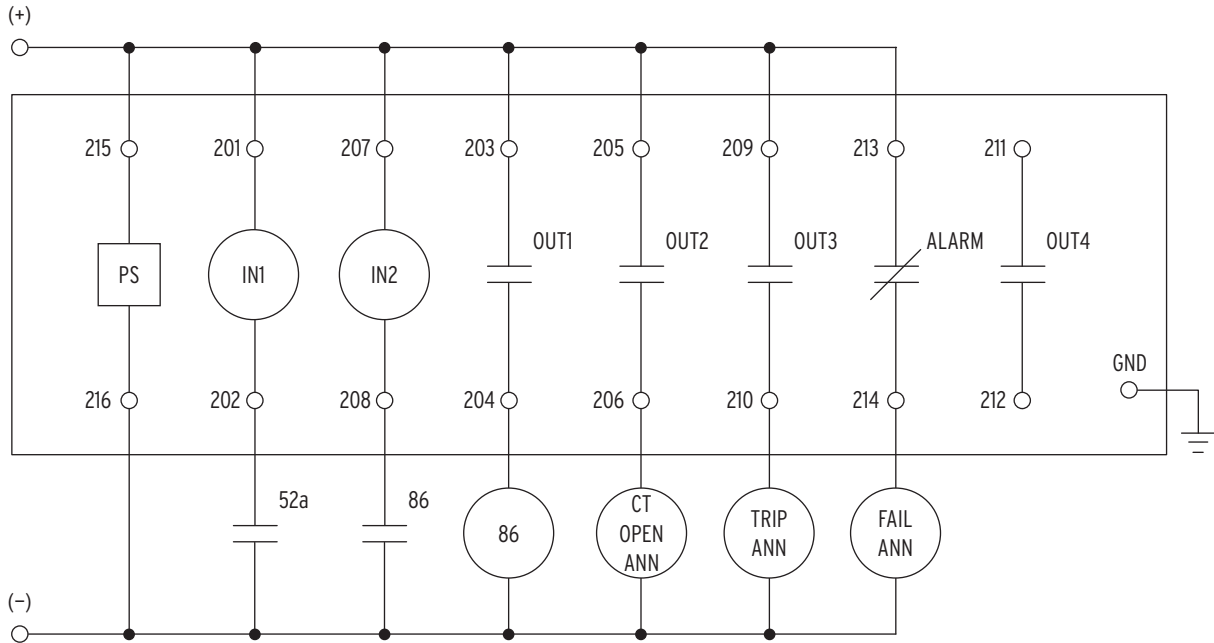
# Wiring Diagrams



**Figure 15** Example AC Connection

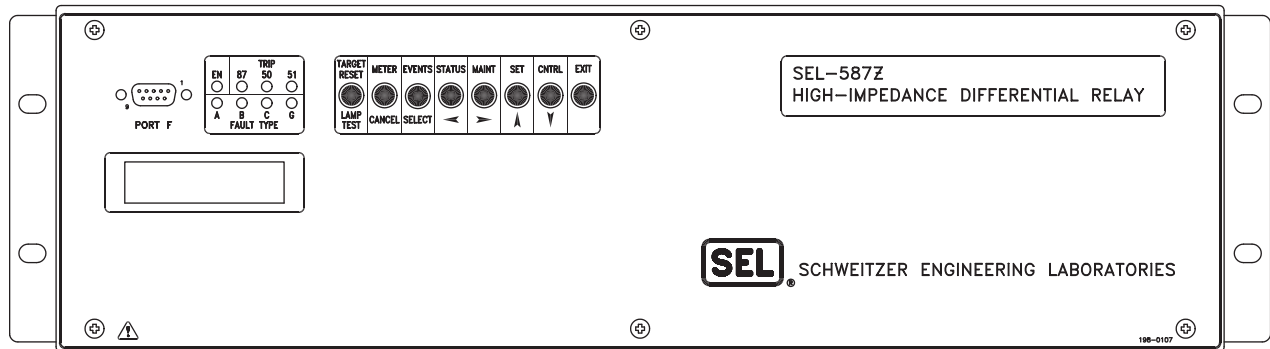


**Figure 16 Example AC Connection With 50/51 Overcurrent Element**



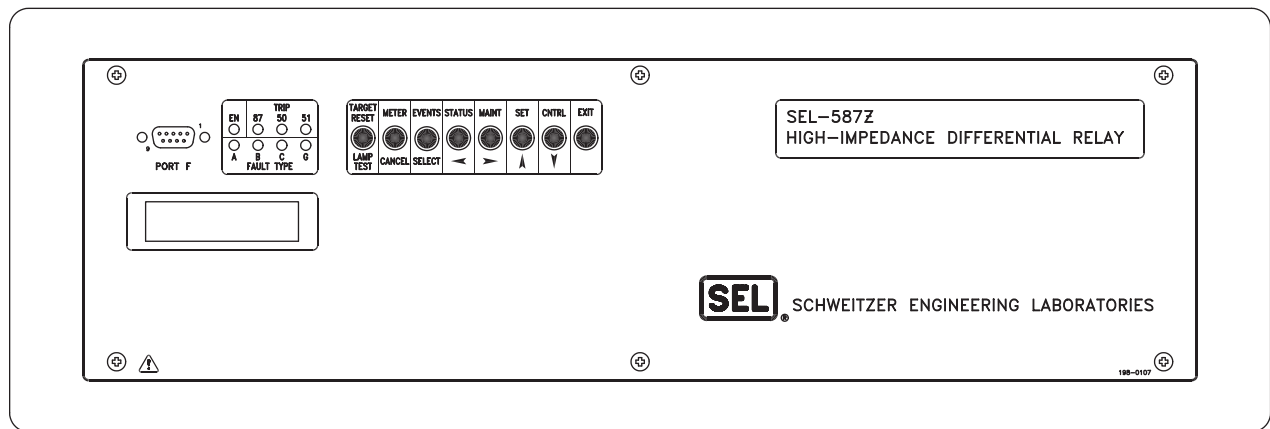
**Figure 17 Example DC Connection**

# Front- and Rear-Panel Diagrams



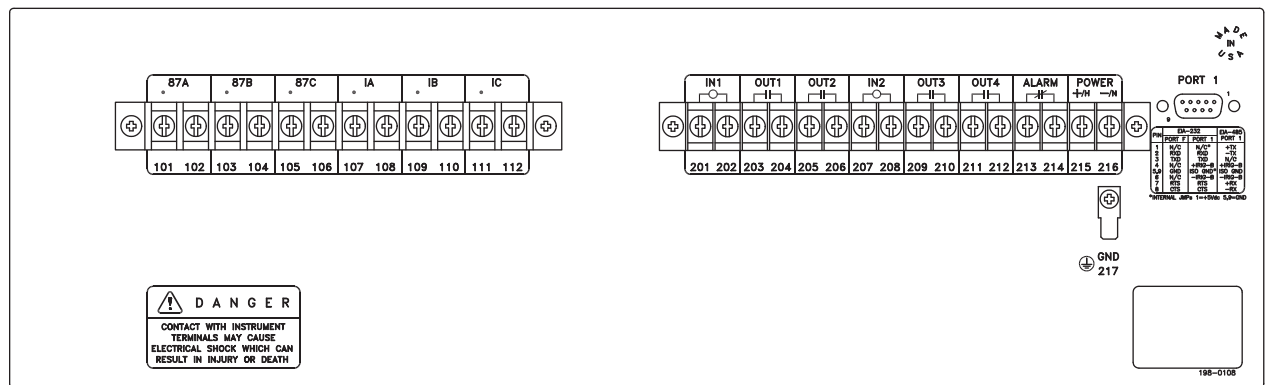
13483b

Figure 18 Front-Panel Diagram, Rack-Mount Option



13481b

Figure 19 Front-Panel Diagram, Panel-Mount Option

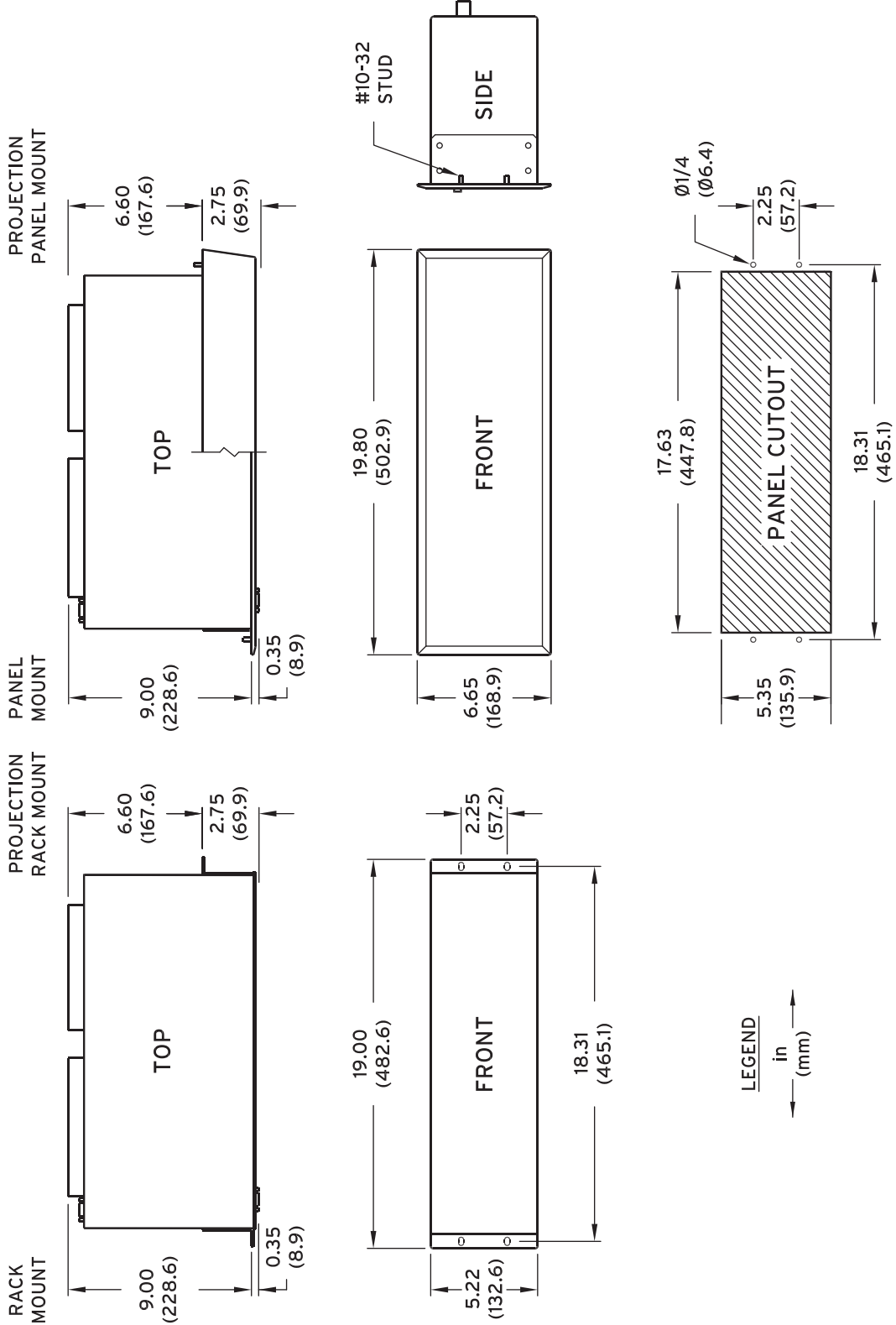


13482b

Figure 20 Rear-Panel Diagram

# Relay Dimensions

## PANEL-MOUNT CHASSIS



i9029c

Figure 21 Dimensions for Rack- and Panel-Mount Models

# Specifications

## Compliance

Designed and manufactured under an ISO 9001 certified quality management system

UL Listed to U.S. and Canadian safety standards (File E212775; NRGU, NRGU7)

CE Mark

UKCA Mark

RCM Mark

**Note:** This equipment has been tested and found to comply with the limits for a Class A digital device, pursuant to part 15 of the FCC Rules. These limits are designed to provide reasonable protection against harmful interference when the equipment is operated in a commercial environment. This equipment generates, uses, and can radiate radio frequency energy and, if not installed and used in accordance with the instruction manual, may cause harmful interference to radio communications. Operation of this equipment in a residential area is likely to cause harmful interference in which case the user will be required to correct the interference at his own expense.

## General

### Terminal Connections

Rear Screw-Terminal Tightening Torque

Minimum:	1.1 Nm (9 in-lb)
Maximum:	1.3 Nm (12 in-lb)

Terminals or stranded copper wire. Ring terminals are recommended. Minimum wire temperature rating of 90°C at 70°C ambient.

### High-Impedance Inputs (87A, 87B, 87C)

200 V nominal:	150 V continuous, linear to 3000 V symmetrical
Burden:	2000 $\Omega$ stabilizing resistance
Range:	20–800 V
Metal-oxide varistor clamping voltage:	One or two MOV option: 2100 V (8 x 20 $\mu$ s) Four MOV Option: 1500 V (8 x 20 $\mu$ s)
Metal-oxide varistor maximum transient energy rating:	One MOV–2500 J Two MOV–5000 J Four MOV–8400 J
Metal-oxide varistor maximum continuous ac voltage rating:	One MOV–750 V Two MOV–750 V Four MOV–600 V

### AC Current Inputs (IA, IB, IC)

5 A nominal:	15 A continuous, 500 A for 1 s, 625 A for 1 cycle (sinusoidal waveform), linear to 100 A symmetrical
Burden:	<0.16 VA @ 5 A, <1.15 VA @ 15 A
Range:	0.5–80 A
1 A nominal:	3 A continuous, 100 A for 1 s, 250 A for 1 cycle (sinusoidal waveform), linear to 20 A symmetrical
Burden:	<0.06 VA @ 1 A, <0.18 VA @ 3 A
Range:	0.1–16 A

**Note:** Use a minimum of C200 CTs or better for high-impedance bus differential applications.

### Frequency and Phase Rotation

System Frequency:	50 or 60 Hz
-------------------	-------------

Phase Rotation: ABC or ACB rotation

### Power Supply

125/250 V	
Range:	85–350 Vdc or 85–264 Vac
Interruption:	100 ms @ 250 Vdc
Ripple:	5%
Burden:	<5.5 W, <23 VA
48/125 V	
Range:	36–200 Vdc or 85–140 Vac
Interruption:	100 ms @ 125 Vdc
Ripple:	5%
Burden:	<5.5 W, <16 VA
24 Vdc	
Range:	16–36 Vdc polarity-dependent
Interruption:	25 ms @ 36 Vdc
Ripple:	5%
Burden:	<5.5 W

**Note:** Interruption and Ripple per IEC 60255-26:2013.

### Output Contacts

**Note:** IEEE C37.90-2005 and IEC 60255-27:2013

Standard Outputs (5 contacts, including the alarm contact):

Make (Short Duration Contact Current):	30 Adc 1000 operations @ 250 Vdc 2000 operations @ 125 Vdc
--	--

Limited Making Capacity: 1000 W @ 250 Vdc (L/R = 40 ms)

Mechanical Endurance: 10000 operations

Rated Voltage: 24–250 Vdc

Operational Voltage Range: 0–300 Vdc

Operating Time: Pickup  $\leq$  6 ms (resistive load)  
Dropout  $\leq$  6 ms (resistive load)

Short Time Thermal Withstand: 50 A for 1 second

Continuous Contact Current: 6 A @ 70°C  
4 A @ 85°C

Contact Protection: MOV protection across open contacts  
300 Vdc continuous voltage  
40 J

Limiting Breaking Capacity/Endurance: 10000 operations  
10 operations in 4 seconds, followed by 2 minutes idle

Rated Voltage	Resistive Break	Inductive Break L/R = 40 ms (DC)
24 Vdc	0.75 Adc	0.75 Adc
48 Vdc	0.63 Adc	0.63 Adc
125 Vdc	0.3 Adc	0.3 Adc
250 Vdc	0.2 Adc	0.2 Adc

## Optoisolated Inputs

Standard Inputs (2 inputs, Control Voltage Jumpers):

24 Vdc:	pickup 15–30 Vdc
48 Vdc:	pickup 30–60 Vdc
125 Vdc:	pickup 80–150 Vdc
250 Vdc:	pickup 150–300 Vdc

**Note:** Optoisolated inputs draw approximately 4 mA of current. All current ratings are at nominal input voltages.

## Communications Ports

Front Port:	EIA-232
Rear Port (Ground Isolated):	EIA-232* or EIA-485* (*order option)
Baud:	300–38400 bps

## Time-Code Input

Relay accepts demodulated IRIG-B time-code input at rear-panel port.

## Humidity

5% to 95% without condensation

## Altitude

2000 m (6560 feet) AMSL

## Operating Temperature

–40° to +85°C (–40° to +185°F)

**Note:** LCD contrast impaired for temperatures below –20°C and above +70°C.

## Weight

4.1 kg (9.01 lb)

## Routine Dielectric Strength Tests (performed on each manufactured relay)

AC current inputs, optoisolated inputs, and output contacts:	2500 Vac for 10 s
Power supply:	3100 Vdc for 10 s

## Type Tests

### Product Family Standard(s)

IEC 60255-26:2013

### Electromagnetic Compatibility Emissions (EMC)

Conducted Emissions:	FCC 15.107, Class A
Radiated Emissions:	CISPR 22:2008, Class A CISPR 11:2010, Class A FCC 15.109:2014, Class A

### Electromagnetic Compatibility Immunity

Conducted RF Immunity:	IEC 60255-26:2013, Section 7.2.8 IEC 61000-4-6:2013 10 Vrms
Electrostatic Discharge Immunity:	IEC 60255-26:2013, Section 7.2.3 IEC 61000-4-2:2008 Levels 2, 4, 6, and 8 kV contact Levels 2, 4, 8, and 15 kV air IEEE C37.90.3-2001 Levels 2, 4, and 8 kV contact Levels 4, 8, and 15 kV air
Electrical Fast Transient Burst Immunity:	IEC 60255-26:2013, Section 7.2.5 IEC 61000-4-4:2012 4 kV @ 5 kHz on power supply and outputs 2 kV @ 5 kHz on communications ports

Power Frequency Immunity:	IEC 60255-26:2013, Section 7.2.9 IEC 61000-4-16:2002 Zone A, applicable to binary input ports only: Differential mode: 150 Vrms Common mode: 300 Vrms
---------------------------	---

**Note:** Always use multicore screened or twisted pair (screened or unshielded) cables on optoisolated inputs (dc binary inputs).

Power Frequency Magnetic Field Immunity:	IEC 60255-26:2013, Section 7.2.10 IEC 61000-4-8:2009 1000 A/m for 3 s 100 A/m for 60 s
Power Supply Immunity:	IEC 60255-26:2013, Sections 7.2.11, 7.2.12, 7.2.13 IEC 60255-27:2013, Sections 5.1.3, 10.6.6
Radiated Electromagnetic Field Immunity:	IEC 60255-26:2013, Section 7.2.4 10 V/m (unmodulated) at swept frequency, 80 MHz–1 GHz, 1.4–2.7 GHz IEEE C37.90.2-2004 20 V/m (unmodulated) at swept frequency 80 MHz–1 GHz
Surge Immunity:	IEC 60255-26:2013, Section 7.2.7 IEC 61000-4-5:2005 0.5, 1.0, 2.0 kV line-to-line 0.5, 1.0, 2.0, 4.0 kV line-to-earth 0.5, 1.0, 2.0 kV communications ports
Surge Withstand:	IEC 60255-26:2013, Section 7.2.6 IEC 61000-4-18:2006 Power supply, outputs, and inputs 2.5 kV peak common mode 1.0 kV peak differential mode Communications ports 1.0 kV peak common mode IEEE C37.90.1-2012 2.5 kV oscillatory 4.0 kV fast transient

## Environmental

Cold:	IEC 60068-2-1:2007 Severity Level: 16 hours @ –40°C
Damp Heat Cyclic:	IEC 60068-2-30:2005 Severity Level: 25° to 55°C, 6 cycles Relative Humidity: 95%
Dry Heat:	IEC 60068-2-2:2007 Severity Level: 16 hours @ +85°C
Vibration Resistance:	IEC 60255-21-1:1988 Class 1 Endurance Class 2 Response
Shock Resistance:	IEC 60255-21-2:1988 Class 1 Shock withstand, Bump Class 2, Shock Response
Seismic:	IEC 60255-21-3:1993 Class 2 Quake Response

## Safety

Dielectric Strength:	IEC 60255-27:2013; Section 10.6.4.3 IEEE C37.90-2005, Section 8 2.5 kVrms on contact inputs, contact outputs, and analog inputs 3.6 kVdc on power supply
Impulse:	IEC 60255-27:2013; Section 10.6.4.2 0.5 J, 5 kV IEEE C37.90-2005, Impulse section



FCC:	This device complies with Part 15 of the FCC rules. Operation is subject to the following two conditions: (1) This device may cause no harmful interference. (2) This device must accept any interference received, including interference that may cause undesired operation. Changes or modifications to this product may void authority to operate this equipment provided in Part 15. Canadian ICES-003: This Class A digital apparatus complies with Canadian ICES-003. Cet appareil numérique de la classe A est conforme à la norme NMB-003 du Canada.
Canadian ICES-003:	This Class A digital apparatus complies with Canadian ICES-003. Cet appareil numérique de la classe A est conforme à la norme NMB-003 du Canada.

### Sampling

16 samples per power system cycle

### Processing

Differential elements, optoisolated inputs, and contact outputs are processed at 1/8-cycle.

Overcurrent elements are processed at 1/8-cycle.

### Metering Accuracy

Instantaneous Currents:

5 A Model:  $\pm 2\% \pm 0.10$  A

1 A Model:  $\pm 2\% \pm 0.02$  A

Demand Currents:

5 A Model:  $\pm 2\% \pm 0.10$  A

1 A Model:  $\pm 2\% \pm 0.02$  A

High-Impedance Voltage:  $\pm 5\% \pm 2$  V

### Differential Element

Pickup Range: 20–800 V

Pickup Accuracy (V secondary):

5 A Model:  $\pm 5\% \pm 4$  V

1 A Model:  $\pm 5\% \pm 4$  V

Pickup Time (Max): 1.25 cycles

### Instantaneous Overcurrent Elements

Pickup Range (A secondary):

5 A Model: 0.5–80.0 A

1 A Model: 0.1–16.0 A

Pickup Accuracy (A secondary):

5 A Model:  $\pm 5\% \pm 0.10$  A

1 A Model:  $\pm 5\% \pm 0.02$  A

Pickup Time (Typ/Max): 0.75/1.25 cycles

### Time-Overcurrent Elements

Pickup Range (A secondary):

5 A Model: 0.5–16.0 A

1 A Model: 0.1–3.2 A

Pickup Accuracy (A secondary):

5 A Model:  $\pm 5\% \pm 0.10$  A

1 A Model:  $\pm 5\% \pm 0.02$  A

Curves:

U1 =	U.S. Moderately Inverse
U2 =	U.S. Inverse
U3 =	U.S. Very Inverse
U4 =	U.S. Extremely Inverse
U5 =	U.S. Short-Time Inverse
C1 =	IEC Class A (Standard Inverse)
C2 =	IEC Class B (Very Inverse)
C3 =	IEC Class C (Extremely Inverse)
C4 =	IEC Long-Time Inverse
C5 =	IEC Short-Time Inverse

Time-Dial Range

U.S. Curves: 0.50–15.00, 0.01 step

IEC Curves: 0.05–1.00, 0.01 step

Timing Accuracy:  $\pm 4\% \pm 2\% \left( \frac{I_{nom}}{I_{sec}} \right) \pm 1.5$  cycles

for current between 2 and 30 multiples of pickup. Curves operate on definite-time for current greater than 30 multiples of pickup or 16 times nominal.

Reset Characteristic:

Induction-disk reset emulation or 1-cycle linear reset

# Technical Support

---

We appreciate your interest in SEL products and services. If you have questions or comments, please contact us at:

Schweitzer Engineering Laboratories, Inc.  
2350 NE Hopkins Court  
Pullman, WA 99163-5603 U.S.A.  
Tel: +1.509.338.3838  
Fax: +1.509.332.7990  
Internet: selinc.com/support  
Email: info@selinc.com

---

© 2002-2022 by Schweitzer Engineering Laboratories, Inc. All rights reserved.

All brand or product names appearing in this document are the trademark or registered trademark of their respective holders. No SEL trademarks may be used without written permission. SEL products appearing in this document may be covered by U.S. and Foreign patents.

Schweitzer Engineering Laboratories, Inc. reserves all rights and benefits afforded under federal and international copyright and patent laws in its products, including without limitation software, firmware, and documentation.

The information in this document is provided for informational use only and is subject to change without notice. Schweitzer Engineering Laboratories, Inc. has approved only the English language document.

This product is covered by the standard SEL 10-year warranty. For warranty details, visit selinc.com or contact your customer service representative.

## SCHWEITZER ENGINEERING LABORATORIES, INC.

2350 NE Hopkins Court • Pullman, WA 99163-5603 U.S.A.  
Tel: +1.509.332.1890 • Fax: +1.509.332.7990  
selinc.com • info@selinc.com

