

Advanced Application Guidelines for Ground Fault Protection

George E. Alexander, Joe Mooney, and William Tyska
Schweitzer Engineering Laboratories, Inc.

Presented at the
28th Annual Western Protective Relay Conference
Spokane, Washington
October 23–25, 2001

ADVANCED APPLICATION GUIDELINES FOR GROUND FAULT PROTECTION

George E. Alexander, Joe Mooney, and William Tyska
Schweitzer Engineering Laboratories, Inc.
Pullman, WA USA

INTRODUCTION

A previous paper [4] described application guidelines for ground fault detection on uncompensated overhead power lines. In that paper the discussion focused on the protection elements and comparisons were based upon sensitivity and security.

The discussion in this paper expands on the same topic and includes discussion on the following:

- Series-Compensated Lines
- Single-Pole Tripping
- Underground Cables

Problem areas of ground fault detection include distance element overreach on series-compensated lines, directional stability on series-compensated lines, directional overcurrent sensitivity in single-pole tripping applications, application of ground distance on cables, and directional overcurrent sensitivity on cables.

This paper offers recommendations on setting and selection of the appropriate ground fault protection elements in the above applications. We also include guidelines for setting ground fault detecting elements. In other cases, we offer recommendations on element selection and identify other possible problem areas.

SERIES-COMPENSATED LINE APPLICATIONS

Series capacitors reduce the overall inductive reactance of a transmission line. Additional information regarding the benefits of series compensation are discussed in detail in various text books and numerous technical papers. In this document, series compensation is simply accepted as a challenge to the protection engineer.

The term “series capacitor” refers to a “bank” of multiple individual capacitor cans connected in a series-parallel arrangement. For simplicity in this paper, we use “series capacitor” in place of the more cumbersome “series capacitor bank.” The capacitor cans and related protective equipment are physically mounted on a raised platform that is insulated from ground.

Since the capacitive reactance, X_c , is in-series with the transmission line inductive reactance, X_l , and $X_c < X_l$, a subharmonic natural frequency transient results following faults or capacitor switching. This can result in protection problems (overreach) and generator problems (subsynchronous resonance).

All series capacitors employ some type of bypass protection to prevent damage caused by overvoltage resulting from high-fault current levels. This bypass protection may be a simple triggered air gap or metal oxide varistors (MOVs). The operation of a triggered gap produces high-frequency transients. Digital or numeric relays, with their analog anti-aliasing filters and

digital filters, effectively mitigate these high-frequency transients, but these same devices must deal with the subharmonic transients. MOVs parallel the capacitor bank with a resistance whose value is dependent upon the magnitude of voltage developed across the capacitor bank during a fault. The effect is to produce a nonsinusoidal waveform and to modify, but not eliminate, the natural frequency subharmonic transient. MOV bypass protection incorporates an air gap that is triggered when the energy exceeds the MOV rating. Thus, the MOV protects the capacitor from overvoltage while the air gap provides thermal protection of the MOV. In either bypass scheme, the capacitor is shorted when the air gap is triggered.

Problem Scope

Much of the existing series-compensated line protection literature focuses on the problems associated with distance and directional functions. While directional integrity and overreach are important issues, the viability of the directional comparison scheme logic is equally important. For instance, additional transient blocking logic may have to be added to provide adequate security against misoperations where directional integrity cannot be maintained for slow clearing faults.

Natural Frequency Transients

For uncompensated transmission lines, protection engineers often feel comfortable applying ground-distance relays based on steady-state fault impedances plotted together with a relay characteristic on an R-X diagram. We do not recommend this approach for series-compensated transmission lines because of the “impedance spiral” produced by the subharmonic transients mentioned above. Fortunately, this impedance spiral can be readily analyzed for ground distance functions implemented in digital or numeric relays that employ a cosine, discrete Fourier transform, or other digital filter.

The following analysis describes the impedance spiral phenomenon. Note that the effects of bypass protection are not considered—the capacitance value never changes. Figure 1 depicts one phase of a series-compensated transmission line. The switch closes at $t = 0$ to apply an AG fault at the remote bus of the transmission line.

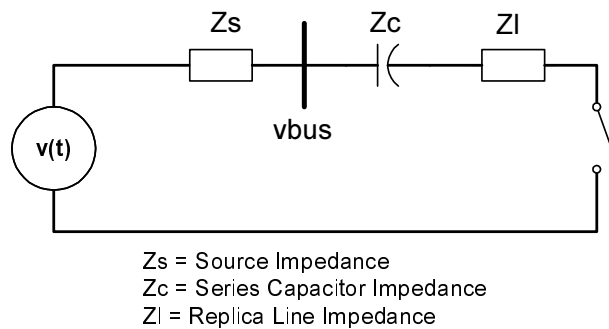

Figure 1 Series-compensated transmission lines

The solution is obtained by solving equation (1) for the fault current $i(t)$ and subsequently solving for the bus voltage $v_{bus}(t)$.

$$v(t) = V \cdot \sin(\omega \cdot t + \theta) = i(t) \cdot R + \frac{di(t)}{dt} \cdot L + \frac{1}{C} \cdot \int i(t) \cdot dt \quad (1)$$

The following values were used:

Source: $Z_{s1} = Z_{s2} = 1 \angle 85^\circ, Z_{s0} = 1 \angle 80^\circ$
 Line: $Z_{l1} = Z_{l2} = 4 \angle 80^\circ, Z_{l0} = 12 \angle 75^\circ$
 Capacitor: $Z_c = 1.33 \angle -90^\circ$
 Voltage: $V = (67)(\sqrt{2})$ volts

The A-phase fault current, $i(t)$, is shown in Figure 2.

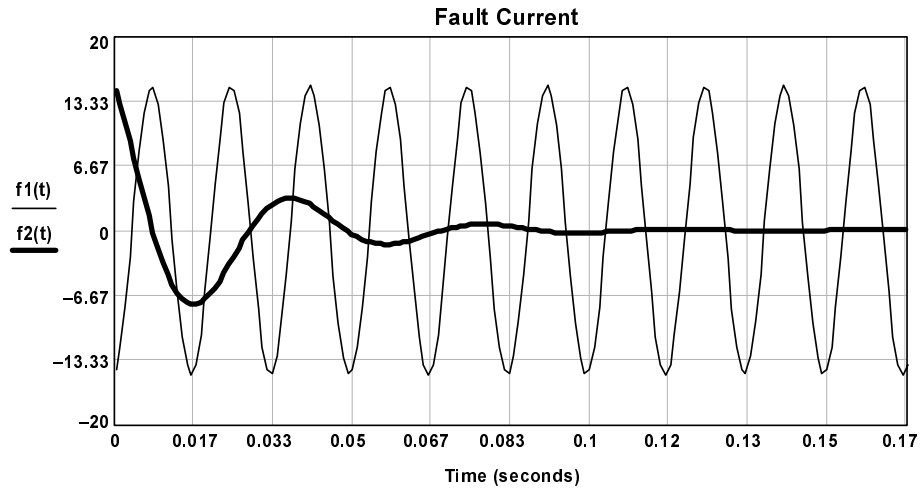

Figure 2 Fault Current Waveforms

In Figure 2, $f_1(t)$ is the 60 Hz component of the A-phase fault current and $f_2(t)$ (the bolded line), is the 24.5 Hz natural frequency transient.

The A-phase voltage, $v_{bus}(t)$, is shown in Figure 3.

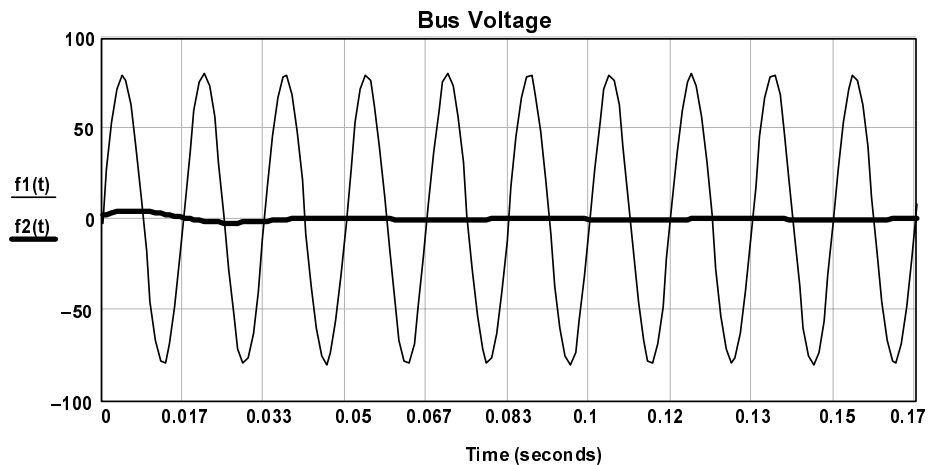

Figure 3 Bus Voltage Waveforms

In Figure 3, $f_1(t)$ is the 60 Hz component and $f_2(t)$ (the bolded line), is the 24.5 Hz natural frequency transient.

The next step is to solve for the apparent impedance seen by the A-phase ground-distance relay. First the time domain solution for $i(t)$ and $v_{bus}(t)$ are sampled 16 times per cycle. A full-cycle nonrecursive digital filter then converts the sampled values to phasors. The current phasors are then compensated by adding $[(Z_0 - Z_1) / Z_1] \cdot I_0$ to the phase current, and the apparent impedance is calculated (where $I_0 = 1/3 \cdot (I_A + I_B + I_C)$).

Figure 4 shows the spiraling impedance caused by the natural frequency transient shown in Figure 2 and Figure 3. Note that immediately after the fault is applied, the spiral characteristic is large and passes through the steady-state impedance characteristic. As the transient decays, the spiral is reduced until it reaches a steady-state value after approximately 5 cycles. The circle that passes through the origin of the R-X diagram represents the steady-state characteristic for a Zone 1 A-phase ground distance mho function set with a 2.5 ohm reach. This setting represents a best guess to prevent Zone 1 overreach for a remote bus fault based on the steady-state impedance. It is apparent that this reach setting must be reduced to prevent Zone 1 operation because of the spiraling impedance.

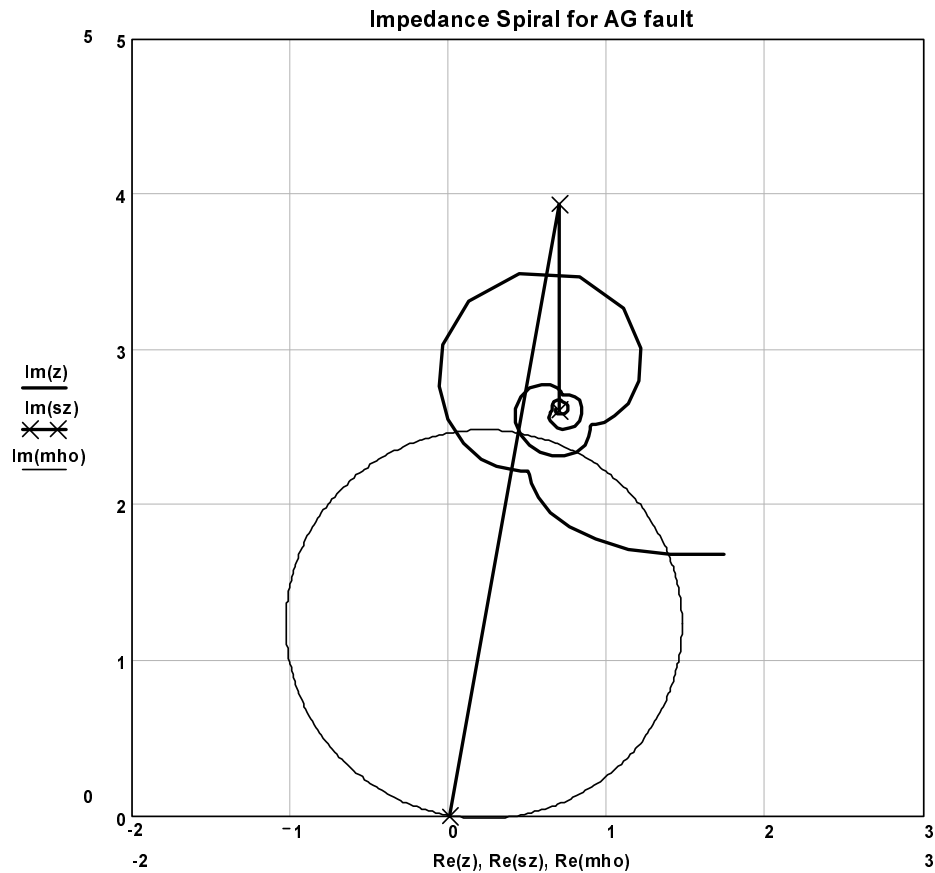

Figure 4 R-X Diagram

Directional Integrity

Directional integrity is defined here as the ability of a directional function—a directional ground distance function, a negative-sequence directional function, or a zero-sequence directional function—to operate (and stay operated for the fault duration) for a forward ground fault (dependability) and to not operate for a reverse ground fault (security). Directional integrity is an

issue even with uncompensated transmission line applications. Series-compensated transmission lines exacerbate the problem because of the possibility of voltage and current reversals.

A voltage reversal occurs for a ground fault near a series capacitor when the impedance from the voltage transformer location to the fault is capacitive rather than inductive. This reversal of the voltage phase angle can create both dependability and security problems.

Figure 5 shows two parallel transmission lines. In each line, a series capacitor is physically located at the left (L) bus. For a ground fault at F on the top line that is close to the series capacitor, the voltage seen by the relays at L on both the top and bottom lines may be reversed. A ground distance relay on the top line could determine that the fault is external rather than internal and block tripping. A ground-distance relay on the bottom line could determine that the fault is internal rather than external and trip incorrectly. A similar scenario could occur for either negative- or zero-sequence directional functions used in a directional comparison scheme.

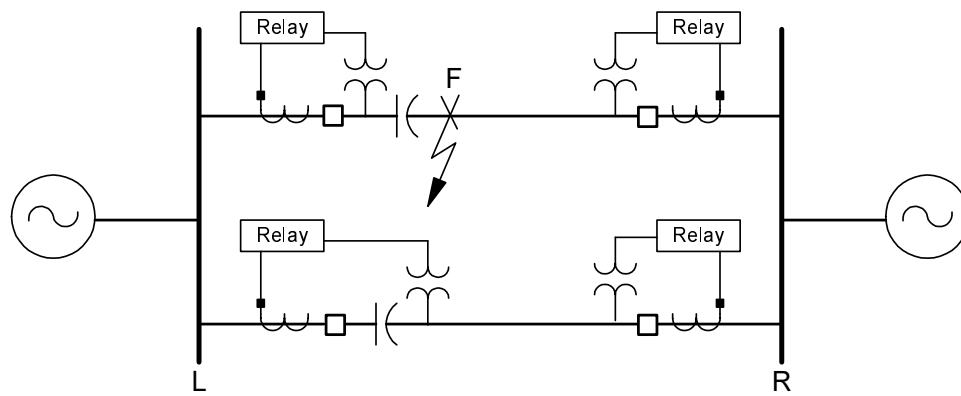

Figure 5 Example System

An effective means to mitigate the effects of a voltage reversal in a ground distance relay is to use the appropriate positive-sequence voltage, V_1 , as the “polarizing” quantity and to use the pre-fault value of V_1 . The pre-fault or “memory” value of V_1 results in a dynamic characteristic that assures proper directional sensing until V_1 transitions to the fault value. With digital or numeric relays, memory algorithms may be implemented with memory persistence ranging from several cycles to infinity. The memory feature ensures that ground distance functions sense the correct direction at fault initiation. Knowing the memory persistence interval allows the user or manufacturer to add the required transient blocking logic to the overall scheme logic to assure proper operation of the directional comparison scheme logic.

A current reversal occurs for a ground fault on the protected-series compensated line when the fault current enters at one end and leaves at the other end, as would occur for an external fault. For the system in Figure 5, if the bottom line is removed, a current reversal can occur for a ground fault at F if the left source impedance is less than the reactance of the series capacitor. If the ground fault at F were a bolted fault, then the large fault current would most likely cause rapid bypassing of the series capacitor. However, a high-resistance fault might reduce the fault current so the series capacitor is not bypassed.

Certain negative- and zero-sequence directional functions can misoperate or fail to operate for current reversals and voltage reversals. The location of the voltage transformers on either the “bus-side” or “line-side” of the series capacitor is one factor that determines what happens. The design of the directional function can mitigate or eliminate these problems. “Compensated”

directional functions provide the user with settings that virtually “move” the function along the line to where correct directional sensing is assured [1].

As an example, the settings for the compensated negative-sequence directional elements described in reference [1] are given for one relay location in Figure 5. Consider the relay located on the bottom line at the left bus (voltage transformer located on the line-side of the series capacitor). First, assume the capacitor bank is shorted (uncompensated line). The suggested impedance threshold settings are:

$$Z2F = \frac{Z_L}{2}$$

$$Z2R = Z2F + \frac{0.5}{I_{rated}}$$

where: Z_L is the positive-sequence impedance of the line
 I_{rated} is the rated current of the relay (1 or 5 A)

The directional element declares a forward fault if the calculated Z2 (negative-sequence impedance) is less than Z2F, and a reverse fault if the calculated Z2 is greater than Z2R.

Now assume that the series capacitor is in-service. Because the relay voltage is supplied from the line-side of the series capacitor, the capacitor impedance must be considered as part of the source impedance behind the relay. If X_C is greater than the source impedance, a voltage reversal could occur for forward-direction faults resulting in improper directional sensing. To prevent this, the Z2F setting must be greater than X_C . The suggested impedance threshold settings are:

$$Z2F = \frac{(Z_L - X_C)}{2} + X_C$$

$$Z2R = Z2F + \frac{0.5}{I_{rated}}$$

where: Z_L is the positive-sequence impedance of the line
 I_{rated} is the rated current of the relay (1 or 5 A)
 X_C is the positive-sequence impedance of the series capacitor

Zero-Sequence Compensation Factor for Ground Distance Functions

A ground distance function applied on a transmission line without series capacitors requires “zero-sequence current compensation” of the phase current to correctly determine the true positive-sequence impedance from the relay to a ground fault. A concise derivation of the zero-sequence current compensation factor is presented in Appendix A.

The zero-sequence current compensation is defined as follows:

$$I_a + k \cdot I_0 \quad k = \frac{Z_0 - Z_1}{Z_1} \quad (2)$$

I_a is the phase current at the relay, and I_0 is the zero-sequence current at the relay. Z_0 is the zero-sequence impedance and Z_1 is the positive-sequence impedance of the protected line. For a series-capacitor compensated transmission line, should the evaluation of k use uncompensated impedances, Z_0 and Z_1 or compensated impedances $Z_0 - jX_c$ and $Z_1 - jX_c$? X_c is the reactance of the series capacitors located between the relay and the end of the line. Voltage transformer location determines relay location. We next evaluate an AG fault at the remote bus for the series-compensated transmission line system in Figure 1 to help answer this question.

Assume that the series capacitor is not bypassed during the fault and that uncompensated values of Z0 and Z1 are used to calculate k.

$$k = \frac{12\angle 75^\circ - 4\angle 80^\circ}{4\angle 80^\circ} = 2\angle -7.5^\circ$$

$$I_a = 10.534\angle -75.3^\circ$$

$$I_0 = 3.511\angle -75.3^\circ$$

$$V_a = 56.597\angle -1.5^\circ$$

$$\frac{V_a}{I_a + k \cdot I_0} = 3.23\angle 76.8^\circ$$

Assuming the voltage transformer is located on the bus-side of the series capacitor, we know that the positive-sequence impedance from the relay to the fault is $4\angle 80^\circ + 1.33\angle -90^\circ = 2.7\angle 75.1^\circ$. The ground distance relay does not calculate the expected value of positive-sequence impedance. Next, assume that k is calculated using compensated values of Z0 and Z1.

$$k = \frac{(12\angle 75^\circ + 1.33\angle -90^\circ) - (4\angle 80^\circ + 1.33\angle -90^\circ)}{(4\angle 80^\circ + 1.33\angle -90^\circ)} = 2.97\angle -2.58^\circ$$

$$\frac{V_a}{I_a + k \cdot I_0} = 2.7\angle 75.1^\circ$$

The desired result is obtained. In fact, the spiraling impedance plotted in Figure 4 was calculated using $k = 2.97\angle -2.58^\circ$.

Therefore, the apparent answer to the question is to calculate k using $Z_0 - jX_c$ and $Z_1 - jX_c$ for ground-distance functions that are expected to operate before the series capacitor is bypassed and to calculate k using Z0 and Z1 for ground-distance functions that are expected to operate after the series capacitor is bypassed. This is one of those logical answers that has no value in practice; the primary variable that determines when or if a series capacitor is bypassed (or the degree of resistor shunting if MOV's are used) is the magnitude of fault current. Because a ground fault at a particular location may be a direct ground or a high-impedance ground depending upon what causes the fault, ground fault current magnitudes may vary for a given fault location.

For the Figure 1 example, using $k = 2.97\angle -2.58^\circ$ could cause a Zone 1 ground-distance function to overreach for a remote bus fault if the transmission line was operated with the series capacitor removed from service (shorted). Consequently, the best practice is to calculate k using the uncompensated values of Z0 and Z1.

Setting and Selection Guidelines

What is the best relay scheme to use for series-compensated transmission line protection—current differential or directional comparison? Before the advent of sophisticated static analog and digital (numeric) relay designs, the most popular answer was phase comparison, a subset of current differential. Today both current differential and directional comparison schemes are available for series-compensated transmission line protection—often from the same manufacturer. Not all current differential relays are suitable. Not all distance/directional function based directional comparison schemes are suitable. The key is to know and evaluate the

capabilities and limitations of a given relay system. Some relays combine current differential and directional comparison schemes in one package.

The required communications channel capabilities should be closely scrutinized. In general, directional comparison schemes require less channel capability than do current differential schemes. With the increasing availability of fiber optics, wider bandwidth channels are often available to allow the use of current differential schemes.

When a user is considering application of a particular relay or relay scheme on a series-compensated line for the first time, pre- and post-purchase testing on a model power system simulator should be considered. In the pre-purchase or evaluation stage, such testing permits screening between competing products and, by increasing the user's general knowledge of the subject, aids in the purchase decision. In the post-purchase stage, such testing increases confidence in the selected settings for a given application.

SINGLE-PHASE TRIPPING AND RECLOSING

Today, many utilities are faced with the need for supplying more reliable power with fewer added transmission lines. One of the means to achieve this goal is the increased use of single-phase tripping of the transmission circuits. In a single-phase tripping scheme, only the faulted phase of the transmission line is interrupted for single line-to-ground faults. This allows power to be transmitted over the line on the two healthy phases while the fault is cleared. This improves both the reliability of power transmission and the stability of the system against power swings. For all faults involving more than one phase, all three phases of the line are opened. There is also a modification of this scheme, referred to as selective phase tripping. In a selective phase tripping scheme, only the faulted phases are interrupted for multiphase faults. This scheme is rarely applied, as the advantages of transmitting power over a single phase are limited.

These schemes are often referred to as single-phase tripping and reclosing, because automatic reclosing must always be used to reestablish the three-phase transmission line following a single-phase trip. Reclosing for multiphase faults is optional and varies with each application.

Scheme Design

All protective relay schemes are designed to detect if a fault is within its zone of protection, and if it is, to issue a trip output so that the fault may be removed from the power system. In single-phase tripping applications, the relay must additionally determine which phase or phases are involved in the fault and then issue the proper trip outputs to open either a single pole of the breaker or all three poles. Thus, a single-phase tripping scheme must have both fault detection capability and faulted phase selection capability. Traditionally, there are two design approaches to meet these requirements.

The first is the "Combined" or "Integrated" scheme. In this type of scheme, the same measuring elements are used for both fault detection and phase selection. An example of this type of scheme might be an individual phase line current differential relay. The individual phase differential elements will detect the fault and determine which phases are involved in the fault.

The second approach is a "Separated" scheme. In this scheme, different elements are used to detect the fault and to determine the faulted phase. An example of this is a three-phase tripping scheme that is converted to single-phase tripping by the addition of phase selector elements and associated logic.

With today's multifunction relays, a single-phase tripping scheme is most likely to be a combination of the traditional schemes. Some of the measuring elements, possibly ground distance functions are designed to respond only to single line-to-ground faults. However, other elements in the relay, such as zero- and negative-sequence overcurrent elements are inherently non-phase selective, and must include separate phase selection elements when applied in single-phase tripping applications.

Effects of an Open Phase

An open phase on a transmission line creates unbalances that can affect not only the relays on the line with the open phase, but also other relays throughout the system. Either the protection elements must be designed to be immune to the effects of unbalances or they must be desensitized (or removed from service) during the open-pole period following a single-phase trip. Consider the simple system of Figure 6. This simple system is used to show the unbalances resulting from an open phase with load. Modeling of an open phase is discussed in Appendix B.

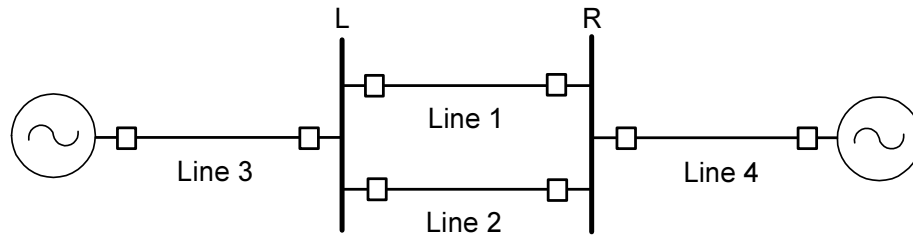

Figure 6 Parallel Line System

Table 1 All Phases Closed

Current (Secondary Amperes)

	Line 1	Line 2	Line 3
IA	2.89 $\angle 20^\circ$	2.89 $\angle 20^\circ$	5.78 $\angle 20^\circ$
IB	2.89 $\angle -100^\circ$	2.89 $\angle -100^\circ$	5.78 $\angle -100^\circ$
IC	2.89 $\angle 140^\circ$	2.89 $\angle 140^\circ$	5.78 $\angle 140^\circ$
I1	2.89 $\angle 20^\circ$	2.89 $\angle 20^\circ$	5.78 $\angle 20^\circ$
I2	0	0	0
I0	0	0	0

Voltages (Secondary)

	Bus L	Bus R
VA	65.3 $\angle 22.63^\circ$	65.3 $\angle 7.37^\circ$
VB	65.3 $\angle -93.37^\circ$	65.3 $\angle -112.63^\circ$
VC	65.3 $\angle 142.63^\circ$	65.3 $\angle 127.37^\circ$
V1	65.3 $\angle 22.63^\circ$	65.3 $\angle 7.37^\circ$
V2	0	0
V0	0	0

Table 2 A-Phase Open in Line 1*Current (Secondary Amperes)*

	Line 1	Line 2	Line 3
IA	0	3.76 $\angle 19.7^\circ$	3.76 $\angle 19.7^\circ$
IB	2.69 $\angle -85.13^\circ$	3.05 $\angle -105.79^\circ$	5.65 $\angle -96.12^\circ$
IC	2.51 $\angle 126.22^\circ$	3.10 $\angle 145.17^\circ$	5.53 $\angle 136.71^\circ$
I1	1.68 $\angle 21.05^\circ$	3.29 $\angle 19.82^\circ$	4.97 $\angle 20.17^\circ$
I2	1.21 $\angle -161.45^\circ$	0.40 $\angle 18.55^\circ$	0.81 $\angle -161.14^\circ$
I0	0.47 $\angle -152.52^\circ$	0.07 $\angle 36.05^\circ$	0.41 $\angle -152.82^\circ$

Voltages (Secondary)

	Bus L	Bus R
VA	65.76 $\angle 25.25^\circ$	65.77 $\angle 4.76^\circ$
VB	65.89 $\angle -97.24^\circ$	64.76 $\angle -112.89^\circ$
VC	64.87 $\angle 143.02^\circ$	65.82 $\angle 127.09^\circ$
V1	65.5 $\angle 23.68^\circ$	65.44 $\angle 6.31^\circ$
V2	1.21 $\angle 103.55^\circ$	1.21 $\angle -76.45^\circ$
V0	0.61 $\angle 111.05^\circ$	0.61 $\angle -68.95^\circ$

If the relay potential is obtained from the line rather than the bus, and zero voltage is assumed for A-phase; then the relay on Line 1 is presented with the following analog signals:

Voltages (Secondary)

	Bus L	Bus R
VA	0	0
VB	65.89 $\angle -97.24^\circ$	64.76 $\angle -112.89^\circ$
VC	64.87 $\angle 143.02^\circ$	65.82 $\angle 127.09^\circ$
V1	43.59 $\angle 22.89^\circ$	43.88 $\angle 7.10^\circ$
V2	21.71 $\angle -157.89^\circ$	21.95 $\angle -172.90^\circ$
V0	21.88 $\angle -156.345^\circ$	21.93 $\angle -172.90^\circ$

Mho Distance Elements

The phase mho distance elements associated with the open phase on the line should be removed from service during the time that the breaker pole is open. For example, when the A-phase is open, the phase distance elements for AB and CA are blocked. This is due to the magnitude and phase angle shift of the phase-to-phase restraint voltage during the open pole.

The ground distance element associated with the open phase should also be removed from service because it may have no restraint voltage. However, the element may still have zero-sequence operating current. Depending on the type of polarizing voltage used in the design of the ground distance elements, the distance elements on the unopened phases may be affected. For example, if quadrature-polarizing voltage is used and the A-phase is open, then the polarizing voltage for

the B- and C-phase ground distance elements are phase shifted similar to the effect of a blown fuse on the A-phase VT. This could result in a misoperation of those distance elements.

The resulting phase shift and magnitude changes for the quadrature-polarizing voltage are shown in Figure 7. The polarizing voltage for the AG ground mho distance elements are shifted ± 30 degrees and reduced in magnitude for an open B- or C-phase. Positive-sequence polarizing voltage angle is relatively unaffected by the open phase.

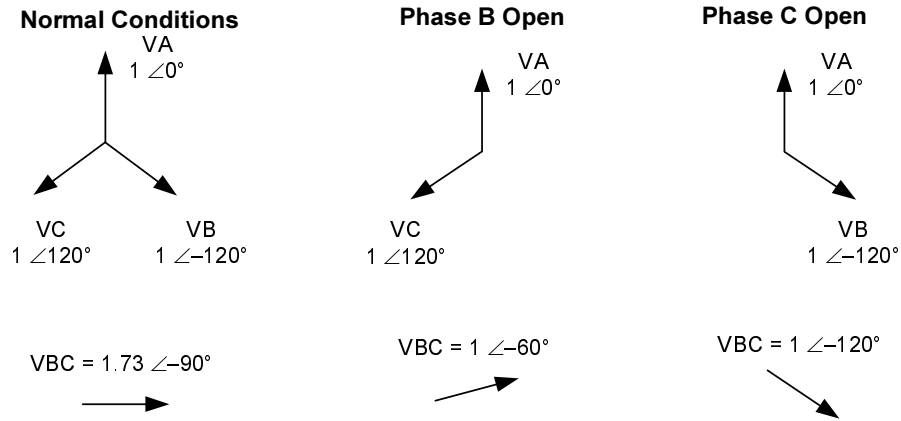

Figure 7 Effect of Open Pole on Quadrature-Polarizing Voltage

The resulting phase shift and magnitude changes for the positive-sequence voltage are shown in Figure 8. The polarizing voltage for the AG ground mho distance elements is reduced in magnitude, but the phase angle does not change.

Positive-sequence polarizing voltage is recommended for mho distance elements used in single-phase tripping applications.

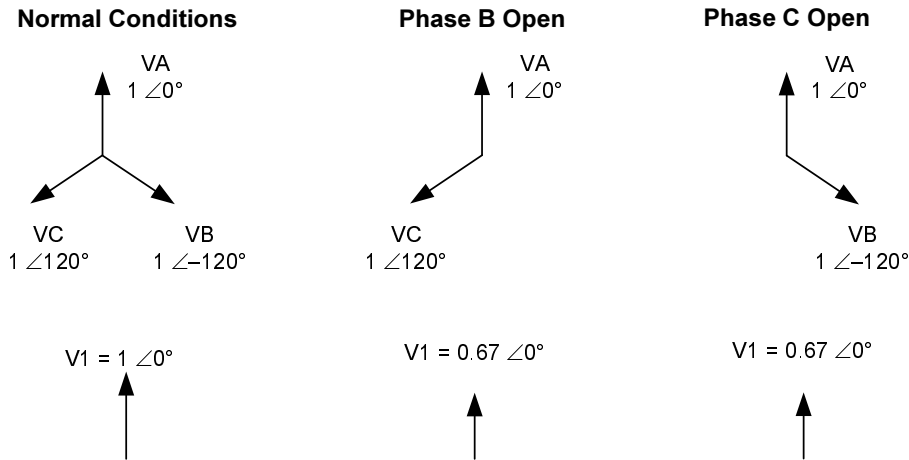

Figure 8 Effect of Open Pole on Positive-Sequence Voltage

Quadrilateral Ground Distance Elements

Because quadrilateral ground distance elements do not use a polarizing voltage, they are not affected by the voltage phase shifts described in the previous section. However, the polarizing signal for a typical quadrilateral ground distance element is derived from zero- and negative-

sequence currents. The unbalanced phase currents created by an open phase on the transmission system have a direct impact on the performance of these quadrilateral ground distance elements. For that reason, it is recommended that any quadrilateral ground distance elements be blocked or removed from service during the open phase period following a single-phase trip.

Directional Elements

The unbalanced voltages and currents introduced into the power system by the open phase affect the performance of both zero- and negative-sequence directional elements. When the potential source for the relay is on the line, the unbalanced voltages have the greatest effect. It is typical practice to disable the standard zero- and negative-sequence directional elements during the period that the breaker pole is open to prevent misoperations of the scheme. As shown previously, the unbalanced currents and voltages may also affect relays on lines that do not have an open phase.

Overcurrent Elements

The open phase has minimal effect on phase overcurrent functions. However, the unbalances associated with the open phase affects the performance and settings of zero- and negative-sequence overcurrent functions. Again, the unbalanced currents are typically highest in the line with the open phase; however, in some system configurations, such as the configuration depicted in Figure 9, the same level of unbalance may occur in adjacent lines.

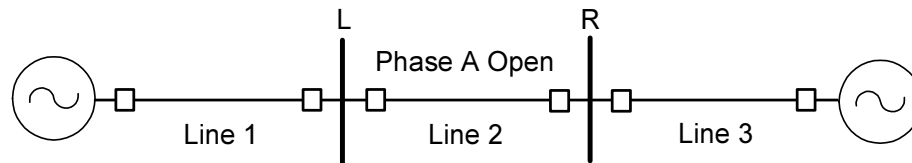

Figure 9 Single Line System

The relays on the line with the open phase are able to determine that the phase is open. This information can be used by the protective scheme to modify the measuring elements and scheme logic thereby preventing any misoperations caused by the unbalanced currents. However, the relays that are not associated with the open-phase line typically do not have that information available to them. Therefore, they must be desensitized to prevent misoperations from the unbalanced currents that are caused by an open phase anywhere in the system.

Sensitivity Considerations

There are two primary areas of sensitivity to consider. The first is the relative sensitivity of the fault detection elements and the phase selection elements. For the best selectivity, the phase selection elements should be more sensitive than the fault detection elements. If the fault detection is more sensitive, the relay may trip the incorrect phase, or all three phases, in an attempt to clear a low-level single line-to-ground fault. This can be a particular problem where high-resistance ground faults may occur.

A second area of sensitivity concern is the response of the relay to the unbalance currents. The fault detecting elements must be set so they do not respond incorrectly to the unbalanced currents caused by an open phase in another line section. This reduced sensitivity can restrict the fault

resistance for which the relay correctly trips. The following table shows the negative- and zero-sequence magnitudes for several conditions based on the simple system of Figure 6.

Table 3 Currents and Voltages (Secondary) Seen by Relay at L2

Condition	I ₂	I ₀	V ₂	V ₀
A-phase open in Line 1	0.40	0.07	1.21	0.61
No open Phases, AG fault 0.5 pu from L2, RF=10 Ω	0.98	0.98	1.47	1.47
No open Phases, AG fault 0.5 pu from L2, RF=25 Ω	0.42	0.42	0.63	0.63
No open Phases, AG fault 0.75 pu from L2, RF=10 Ω	0.63	0.56	1.13	0.94
No open Phases, AG fault 0.75 pu from L2, RF=25 Ω	0.26	0.24	0.48	0.40

The signal magnitudes for internal fault conditions may be of a similar magnitude, or even less than, that caused by an open phase in the parallel line. The unbalances of the open phase may cause large errors in the measurements if the relay is set too sensitive.

Desensitizing Overcurrent Elements

Raising the ground overcurrent or negative-sequence current threshold prevents operation during an open-phase condition. Furthermore, raising the pickup threshold also reduces the ability of the overcurrent element to detect high-resistance faults.

Using a voltage threshold on the directional element is another way to reduce the directional element sensitivity. Placing a voltage threshold on the directional decision dramatically reduces the fault resistance coverage of the relay [5], and may cause coordination difficulties. Selecting an arbitrary threshold works in some cases but not all; therefore, the task is to determine where the voltage threshold should be set. From the previous exercise, the negative- and zero-sequence voltage magnitudes changed with respect to source and load flow. Consequently, it is difficult to determine a setting for the voltage threshold that addresses all systems and conditions. Therefore, the recommended solution is to increase the setting of the ground and negative sequence overcurrent elements.

Special Conditions

Evolving Faults

The term evolving fault is applied when a fault begins as single line-to-ground, but involves an additional phase or phases shortly after fault initiation. The fault may evolve before the initial single line-to-ground fault is cleared or during the open-pole period following a successful single-phase trip. When an evolving fault occurs, the protective relay system must be able to correctly determine the fault type and initiate three-phase tripping with no significant time delay added because of the change of faulted phase information. The protection scheme must also provide the proper information to the associated auto-reclosing logic. The fault type selection logic should run every protection processing interval to ensure high speed fault type determination in the event of an evolving fault.

Cross-Country Faults

The term cross-country fault is applied when multiple faults occur on the system at the same time and at different locations. For example, an A-phase-to-ground fault may occur on the protected line at the same time that a B-phase-to-ground fault occurs on an adjacent or parallel line. A cross-country fault may have minimal effect on a three-phase tripping application, but may present a major problem to a single-phase tripping application.

Consider the simple system of Figure 10, with distance type protection.

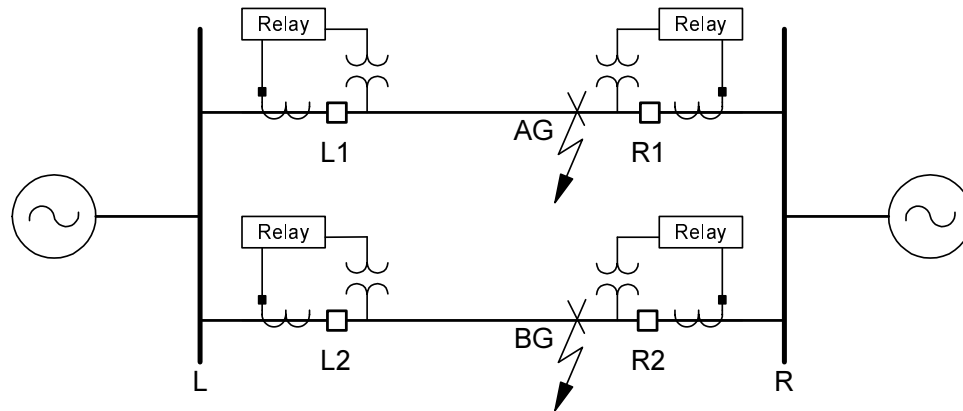

Figure 10 Cross-Country Fault

For most applications, the relay at R1 correctly identifies the fault as a single line-to-ground fault on A-phase, and the relay at R2 correctly identifies the fault as a single line-to-ground fault on B-phase. The situation is not that simple for the relays at Bus L. Both of these relays sense the fault as an ABG double line-to-ground fault because the two single line-to-ground faults are at essentially the same electrical point on the system. As the fault location is moved away from the Bus R towards the center of the line, the relays can more easily distinguish the internal faulted phase from the external faulted phase. In a simple pilot scheme, the fault depicted in Figure 10 may result in correct single-phase tripping by the relays at R1 and R2, but incorrect three-phase tripping by the relays at L1 and L2. This is because the pilot channel information is only two state: either the relays see a fault or they do not see a fault. The faulted phase selection must be accomplished by the local relays. In this case, the relays at L1 and L2 select an ABG fault type resulting in a three-phase trip for a single line-to-ground fault. Several approaches may be employed to avoid this misoperation:

- The pilot tripping can be delayed long enough that the Zone 1 elements at Bus R initiate single-phase tripping. After the breakers at Bus L open the faulted phases, the relays at L1 and L2 see only the internal single line-to-ground faults.
- Multiple two state pilot communications channels can be used to transmit phase identification in addition to trip permission.
- A digital pilot communications channel can be used to transmit multiple bits of information such as faulted phase selection in addition to the permissive signal.

The first solution introduces time delay and requires that the protection on the parallel line operate to clear the fault on the parallel line. The second solution improves upon the first, however, the scheme requires that the channels switch states simultaneously and a switching transition may be interpreted as a different fault type. The last solution is the best option. A digital pilot communications channel provides the best performance [6].

A per phase line current differential scheme may be able to correctly identify the internal single line-to-ground faults in this case. However, it may not be sensitive to high-resistance faults.

The cross-country fault may also be an evolving fault. In Figure 10, the AG fault on Line 1 may occur before the BG on Line 2. When this occurs, the relay at L2 may select AG as the initial faulted phase. This may cause additional phase-selection problems when the internal BG fault occurs. In some cases, the relay at R2 may even initiate an incorrect single-phase trip on B-phase. The digital communications channel, when used with a fast fault type selection logic, can prevent this misoperation.

UNDERGROUND/SUBMARINE CABLE APPLICATIONS

Protective relaying requirements for cables are different from those for overhead lines. The impedance characteristics for cables are significantly different from the impedance characteristics of overhead lines. The shunt capacitance for cables is greater than overhead lines, thus resulting in more line-charging current on a per-unit distance basis. Typically, the length of the cable is relatively short (less than 50 km) when compared to overhead transmission lines.

Cable impedances vary greatly with respect to the cable construction, insulating medium, and shielding method [2]. One of the more well-known cable characteristics is that the sequence-impedances have low angles. Typical overhead transmission lines have impedance angles greater than 70 degrees. Cable impedance angles are typically less than 70 degrees. The zero-sequence line impedance can vary with respect to the zero-sequence current return path. In some configurations, the zero-sequence impedance changes with respect to the magnitude of the zero-sequence current.

The shunt capacitive reactance characteristics are significantly different from those of overhead lines. In some cable configurations the positive-, negative-, and zero-sequence shunt capacitance are all the same. The insulating medium can also have a significant impact on the shunt capacitance. The shunt capacitance for overhead lines is a function of the conductor height from ground and the conductor spacing, whereas the shunt capacitance value for a cable is primarily a function of the single-conductor geometry, shielding, and the dielectric.

Protection of Cables

Line differential relays have traditionally been applied for protection of cables. This paper focuses on distance and directional element applications. Negative-sequence directional elements have been used as an alternate to line current differential protection [2]. Due to the uncertainty of the zero-sequence impedance of some underground cable configurations, zero-sequence directional elements are not recommended. Negative-sequence elements provide very good fault resistance coverage and directional security since the negative-sequence impedances are stable and predictable.

Ground distance protection schemes have also been applied on underground cables. Using ground distance relays requires extended setting ranges for the zero-sequence compensation factor. In addition, the short distances (and thus, low impedances) used for cables may make application of distance relays prohibitive in many cases.

Ground Distance Relay Application

Careful consideration must be given to applying ground distance relays on cables. The zero-sequence impedance can vary depending upon the earth return path. In some cases, the zero-sequence impedance may change with respect to the magnitude of the zero-sequence current.

As an example, let us look at the cable impedance for a particular 800-kcmil copper, paper insulated, lead sheath cable:

$Z1 = 0.113 \Omega/\text{km} \angle 56.8^\circ$	
$Z0 = 1.041 \Omega/\text{km} \angle 6.8^\circ$	Sheath Return Only
$Z0 = 0.977 \Omega/\text{km} \angle 27.9^\circ$	Sheath and Earth Return
$Z0 = 2.414 \Omega/\text{km} \angle 84.4^\circ$	Earth Return Only

Using Equation (2), the zero-sequence compensation factors for each zero-sequence impedance are listed below:

$k0 = 8.604 \angle -55.1^\circ$	Sheath Return Only
$k0 = 7.786 \angle -32.4^\circ$	Sheath and Earth Return
$k0 = 20.482 \angle 28.9^\circ$	Earth Return Only

We next modeled a 10 km section of the above cable in a simple two-source system with the source impedances set equal to each other. Ground faults are taken at 100 percent of the line length using the three different zero-sequence line impedances and zero-sequence compensation factors. The apparent ground fault impedance is calculated for each earth return path and zero-sequence compensation factor. We also calculated distance element measurements for a ground mho, a ground quadrilateral with zero-sequence current polarizing, and a ground quadrilateral with negative-sequence current polarizing.

Table 4, Table 5, and Table 6 list the resulting distance element measurements in per-unit of line length. A per-unit measurement of less than one indicates that the distance element overreaches. A per-unit measurement greater than one indicates that the distance element underreaches. All faults and measurements are taken at 100 percent of the line impedance.

Table 4 Zero-Sequence Compensation Factor Using Sheath Return Only

Sheath Return Only ($k0 = 8.604 \angle -55.1^\circ$)

Z0 Impedance	Apparent Z	Mho	Quad-IR	Quad-I2
Sheath Return Only	$1.13 \Omega \angle 56.8^\circ$	1.00	1.00	1.00
Sheath and Earth Return	$1.1 \Omega \angle 74.6^\circ$	1.40	2.08	1.72
Earth Return	$2.42 \Omega \angle 120.1^\circ$	5.04	6.76	7.84

Table 5 Zero-Sequence Compensation Factor Using Sheath and Earth Return

Sheath and Earth Return ($k0 = 7.786 \angle -32.4^\circ$)

Z0 Impedance	Apparent Z	Mho	Quad-IR	Quad-I2
Sheath Return Only	$1.15 \Omega \angle 39.0^\circ$	0.76	0.46	0.61
Sheath and Earth Return	$1.13 \Omega \angle 56.8^\circ$	1.00	1.00	1.00
Earth Return	$2.42 \Omega \angle 102.9^\circ$	3.18	3.65	3.89

Table 6 Zero-Sequence Compensation Factor Using Earth Return Only

Earth Return Only ($k_0 = 20.482 \angle 28.8^\circ$)

Z0 Impedance	Apparent Z	Mho	Quad-IR	Quad-I2
Sheath Return Only	$0.53 \Omega \angle -10.7^\circ$	0.31	0.12	0.19
Sheath and Earth Return	$0.52 \Omega \angle 7.7^\circ$	0.37	0.25	0.28
Earth Return	$1.13 \Omega \angle 56.8^\circ$	1.00	1.00	1.00

The results shown in Table 4, Table 5, and Table 6 demonstrate that selection of the appropriate zero-sequence compensation factor is critical in ensuring correct distance element reach. Using the wrong zero-sequence compensation factor can result in severe under- or overreach.

The test results also show that using a distance-based scheme for this particular cable may not be the best choice. However, of the three ground distance elements studied, the mho ground element provided the best performance in terms of minimizing under- and overreach.

For this cable configuration, the best selection for the zero-sequence compensation factor for an underreaching distance element is the sheath return only. Note that if the current return path is not the sheath, the underreaching ground distance element may not operate. Using the earth or sheath and earth return would result in severe overreach when the ground current return path is not the path selected for setting the zero-sequence compensation factor.

The best selection for an overreaching ground distance element would be the earth return only. However, this choice may not be appropriate for time delayed backup protection where the relay may have a tendency to underreach for external faults if the return path is not the earth return. If the overreaching element is used in a pilot scheme, then using the earth return is the appropriate choice, as the element always operates correctly for internal faults regardless of the ground current return path.

Using ground distance in cable applications requires careful analysis. If the zero-sequence impedance is known and fixed (e.g., the zero-sequence impedance does not change with respect to return path or fault magnitude), then ground distance relays may be used in the application. However, in most cable applications, the zero-sequence impedance may not be known, thus making it difficult to apply ground distance protection.

Directional Overcurrent

Directional overcurrent relays provide a good alternative to traditional line current differential or distance-based protection. Using directional overcurrent relays in a directional comparison scheme can provide secure, high-speed tripping [2].

Use of directional overcurrent elements requires study and consideration of the cable shunt capacitance. The cable shunt capacitance can impact the overcurrent element in two ways: directional security and sensitivity.

Figure 11 shows the negative-sequence current distribution for an external ground fault. Note that the shunt capacitance current of the cable subtracts from the fault current flow from Terminal R to Terminal S.

$$I_{2S} = I_{2R} - I_{2CR} - I_{2CS}$$

where: I_{2R} = Negative-sequence fault current supplied from Source R

I_{2S} = Negative-sequence fault current flowing through the line terminal at Station S

I_{2CR} = Negative-sequence shunt current at Station R

I_{2CS} = Negative-sequence shunt current at Station S

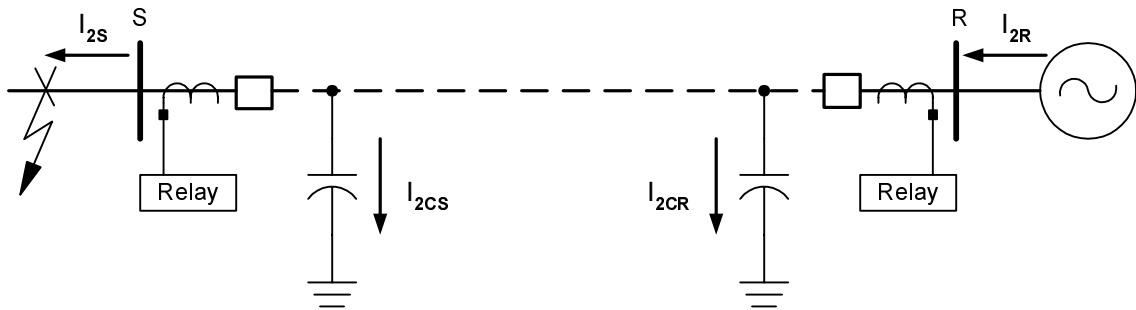

Figure 11 Negative-Sequence Current Distribution—External Fault

The pickup of the reverse element at Station S must be set more sensitively than the forward element at Station R. This is to ensure proper coordination for external fault in the directional comparison scheme. If the forward element picks up at Station R without operation of the reverse element at Station S, unwanted tripping may occur at Station R. Therefore, the pickup thresholds at Stations R and S must be set to accommodate the capacitive current supplied by the cable.

The directional element is also affected by the cable shunt capacitance. One directional element design [1] [3] uses an impedance-based technique for determining fault directions. For reverse faults (refer to Figure 11), the equivalent impedance includes the shunt capacitance of the cable [2]. The cable capacitance can modify the characteristic as shown in Figure 12.

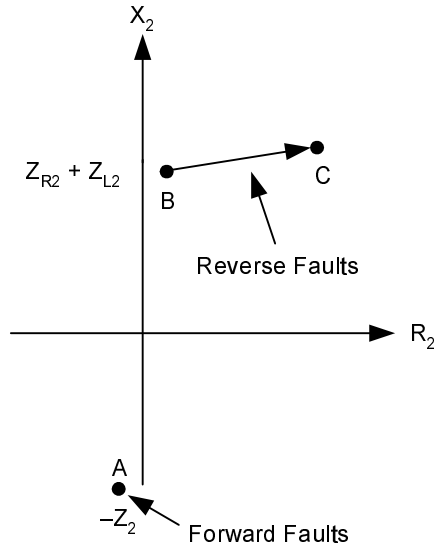

Figure 12 Negative-Sequence Impedance Measurement

Point A illustrates the measured negative-sequence impedance for a forward fault at Station S. Point B illustrates the measured negative-sequence impedance for a reverse fault behind Station S without considering the shunt capacitance. Point C illustrates the measured negative-sequence impedance for a reverse fault with the shunt capacitance.

Figure 12 shows that an impedance-based directional element is not affected by the cable shunt capacitance. The measured impedance for a reverse fault moves in the lateral direction and does not “reduce” the measured impedance value [1]. However, other directional element designs should be evaluated carefully to ensure correct operation.

CONCLUSIONS

1. Underreaching ground distance elements can overreach when applied on series-compensated lines because of the low frequency transients generated during a fault. The overreach is maximized when the capacitor is between the fault and the relay.
2. Directional elements and distance element polarizing quantities must be designed to accommodate voltage inversions caused by series capacitors.
3. Single-pole tripping schemes require secure phase selection algorithms to ensure correct single-phase tripping. Overcurrent elements can be used in single-pole tripping schemes if the phase selection logic is designed to supervise the overcurrent elements.
4. Overcurrent elements used on or near single-pole tripping applications must be set so they do not operate during the open-pole period on adjacent lines.
5. Some cable configurations cause the zero-sequence impedance to change with respect to the current return path or the magnitude of the zero-sequence current. Ground distance relays used on cables must have different zero-sequence compensation factors for under- and overreaching elements.
6. Directional and sensitive overcurrent elements applied to cable protection must be set to accommodate the cable shunt capacitance to ensure proper operation.

REFERENCES

- [1] Jeff Roberts and Armando Guzmán, “Directional Element Design and Evaluation,” 21st Annual Western Protective Relay Conference, Spokane, Washington, October 18-20, 1994.
- [2] Jesus Vargas, Armando Guzmán, Jorge Robles, “Underground/Submarine Cable Protection Using A Negative-Sequence Directional Comparison Scheme,” 26th Annual Western Protective Relay Conference, Spokane, WA, October 1999.
- [3] E. O. Schweitzer III and J. Roberts, “Distance Relay Element Design,” 19th Annual Western Protective Relay Conference, Spokane, WA, October 1992.
- [4] Joe Mooney and Jackie Peer, “Application Guidelines for Ground Fault Protection,” 24th Annual Western Protective Relay Conference, Spokane, WA, October 1997.
- [5] Jeff Roberts, Edmund O. Schweitzer, Renu Arora, and Ernie Poggi, “Limits to the Sensitivity of Ground Directional and Distance Protection”, 22nd Annual Western Protective Relay Conference, Spokane, WA, October 1995.
- [6] Kenneth C. Behrendt, “Relay-to-Relay Digital Logic Communication for Line Protection, Monitoring, and Control”, 23rd Annual Western Protective Relay Conference, Spokane, WA, October 1996.
- [7] Anderson, P.M., and Farmer, R.G., Series Compensation of Power Systems, PBLSH! Inc., Encinitas, CA, 1996.

APPENDIX A GROUND DISTANCE ELEMENT k FACTOR

Derivation of the phase current compensation factor, k, for ground distance functions:

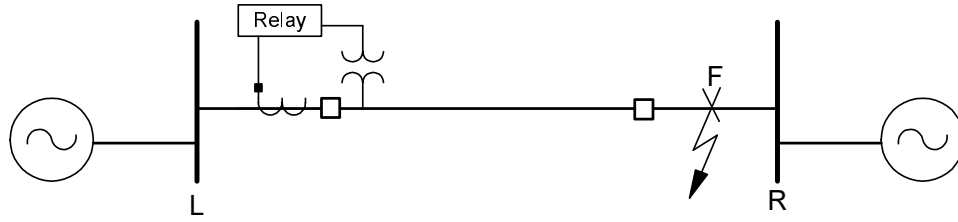

A ground distance relay is located at Bus L and an AG fault is applied at Bus R.

Z_1 = positive-sequence impedance of Line L-R

Z_2 = negative-sequence impedance of Line L-R ($Z_1 = Z_2$)

Z_0 = zero-sequence impedance of Line L-R

$$I_a = I_1 + I_2 + I_0$$

$$\begin{aligned} V_a &= I_1 \cdot Z_1 + I_2 \cdot Z_2 + I_0 \cdot Z_0 \\ &= I_1 \cdot Z_1 + I_2 \cdot Z_1 + I_0 \cdot Z_1 + (I_0 \cdot Z_0 - I_0 \cdot Z_1) \\ &= I_a \cdot Z_1 + I_0 \cdot (Z_0 - Z_1) \end{aligned}$$

$$Z_{\text{apparent}} = \frac{V_a}{I_a} = Z_1 + \frac{I_0}{I_a} \cdot (Z_0 - Z_1)$$

$$V_a = I_a \cdot Z_1 + I_0 \cdot (Z_0 - Z_1)$$

$$\frac{V_a}{Z_1} = I_a + \left(\frac{Z_0 - Z_1}{Z_1} \right) \cdot I_0$$

$$Z_1 = \frac{V_a}{I_a + \frac{Z_0 - Z_1}{Z_1} \cdot I_0}$$

$$\text{Set } k_0 = \frac{Z_0 - Z_1}{Z_1}$$

$$\text{Therefore, } Z_1 = \frac{V_a}{I_a + k_0 \cdot I_0}$$

Note that 'k' is a complex number, but $|k|$ is often used instead to yield an approximate rather than an exact compensation of the phase current.

APPENDIX B MODELING OPEN-PHASE CONDUCTORS

Assume that a conductor can open anywhere along the protected line section. In these cases, any one solution must not be dependent upon the location of the open conductor. For simplicity, assume the open is in the middle of the line at $m = 0.5$ for the system shown in Figure 13 (where m = per-unit line length).

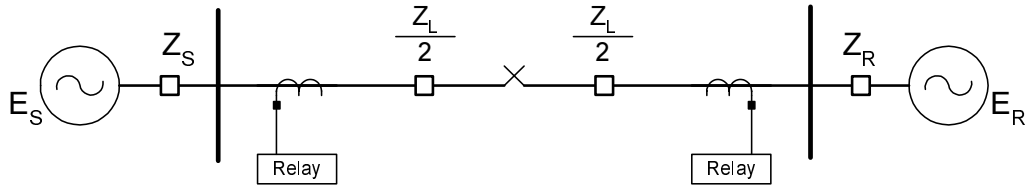
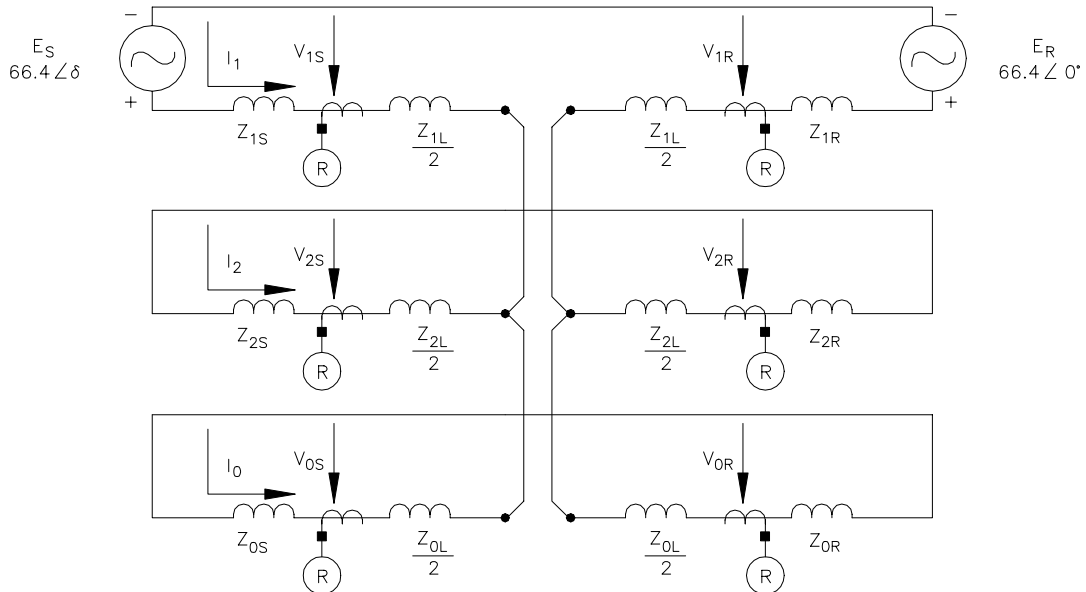

Figure 13 Single Line Diagram of Example System

The symmetrical components connection for a single-phase open condition is shown in Figure 14. The connection diagram shown in Figure 14 is very similar to that of a mid-line phase-to-phase-to-ground fault (Figure 15).

In Figure 14, the through load positive-sequence current divides between the negative- and zero-sequence networks (i.e., $I_1 = -(I_2 + I_0)$). The relationship of $I_1 = -(I_2 + I_0)$ is identical to that obtained for a phase-to-phase-to-ground fault on a radial system with the remote breaker open. The relays at both ends of the line are also subjected to the same sequence currents since I_1 , I_2 , and I_0 are the equivalent for both ends of the line.



DWG: M1000001

Figure 14 Symmetrical Components Connection for Single-Phase Open Condition

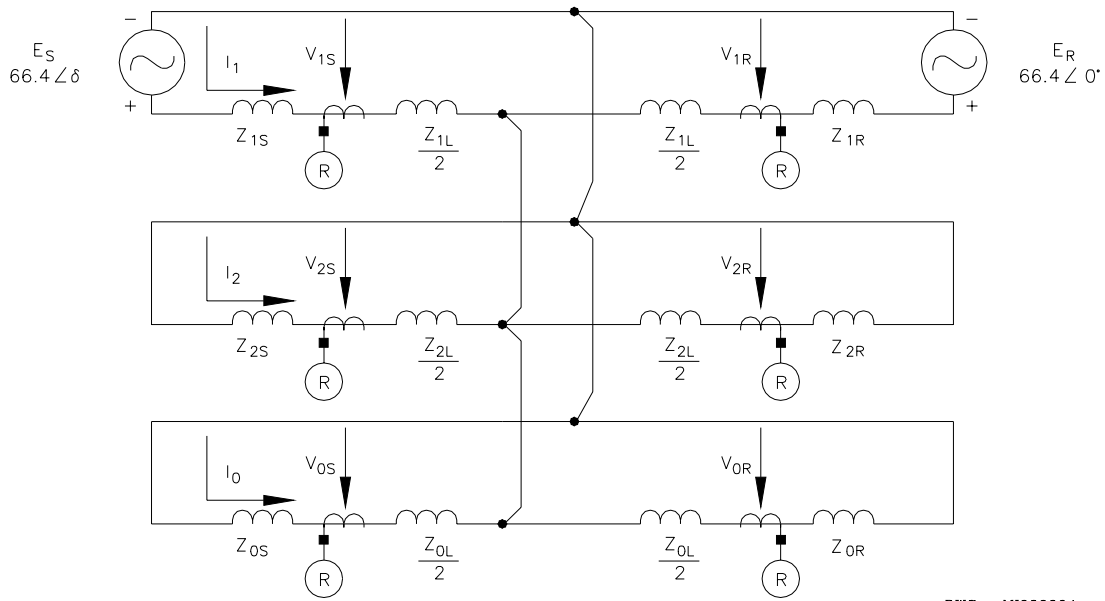

DWG: M1000004

Figure 15 Symmetrical Components Connection for Phase-to-Phase-to-Ground Fault

The symmetrical component connection in Figure 15 can be reduced to a parallel connection of the negative- and zero-sequence networks in series with the positive-sequence line and source impedances shown in Figure 16. Reducing the network shows that the negative- and zero-sequence currents are flowing in opposite directions on the supply bus (the bus supplying pre-fault load current) and the load bus for this system.

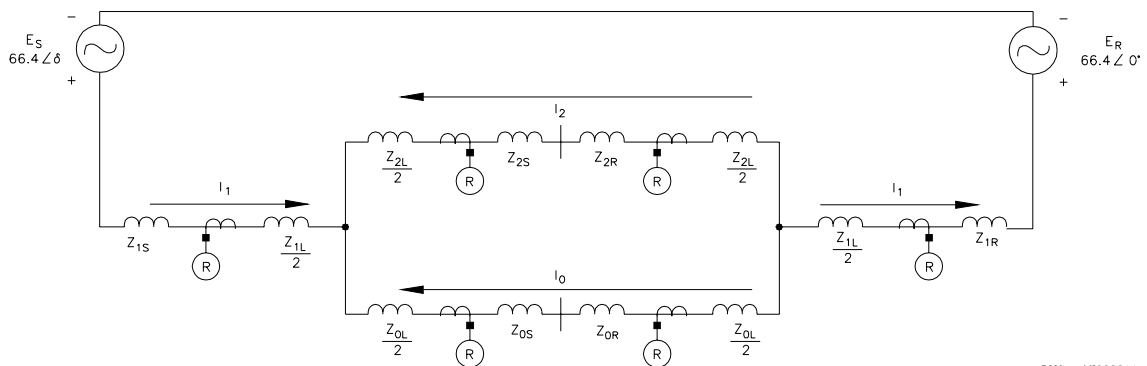

DWG: M1000011

Figure 16 Simplified Parallel Connection, Negative- and Zero-Sequence Networks

A single-phase open condition during load presents the relays at both ends of the line with negative- and zero-sequence currents and voltages. The magnitudes of negative- and zero-sequence currents and voltages produced are determined by the load flow and the strength (magnitude and angle) of the sources. If the load flow is zero, no sequence current operating quantities are supplied to the relays. As load flow increases, the sequence current operating quantities available to the relays become larger.

BIOGRAPHIES

George E. Alexander holds a BSEE degree from Villanova University and an MSEE degree from Drexel University. He is a registered professional engineer in the state of Pennsylvania. He has over 30 years experience in the design and application of transmission line relaying, and holds several U.S. patents in this area. Mr. Alexander has been involved in the development and Model Power System testing of solid state, hybrid analog/digital and fully digital protective relaying systems. He joined SEL in 1999, and is currently regional service manager for the North U.S. and Eastern Canada.

Joseph B. Mooney, P.E., received his B.Sc. in Electrical Engineering from Washington State University in 1985. He joined Pacific Gas and Electric Company upon graduation as a System Protection Engineer. In 1989, he left Pacific Gas and Electric and was employed by Bonneville Power Administration as a System Protection Maintenance District Supervisor. In 1991, he left Bonneville Power Administration and joined Schweitzer Engineering Laboratories as an Application Engineer. Shortly after starting with SEL, he was promoted to Application Engineering Manager. In 1999, he became Manager of the Power Engineering Group of the Research and Development department at Schweitzer Engineering Laboratories. He is a registered Professional Engineer in the states of California and Washington.

William Tyska received a BSEE from Clarkson University and subsequently completed GE's Power System Engineering Course. His work experience includes design and application of protective relay equipment for 30+ years with GE. He is the author or co-author of 15 relay conference papers related to power system protection. Presently, he is employed as a power engineer in the King of Prussia, PA office of Schweitzer Engineering Laboratories, Inc.