

# MCC Arc-Flash Protection Using the SEL-849 Motor Management Relay Via IEC 61850

Alan Saldivar

## INTRODUCTION

Electrical rotary machinery poses several safety risks to workers in various industries. In low-voltage motor control centers (MCCs), arc-flash hazards are especially common. This application note discusses how the SEL-849 Motor Management Relay, SEL-2730M Managed 24-Port Ethernet Switch, and SEL-751A Feeder Protection Relay can be used to protect workers from arc-flash hazards in MCCs. Figure 1 depicts a typical motor bucket configuration using the SEL-849.

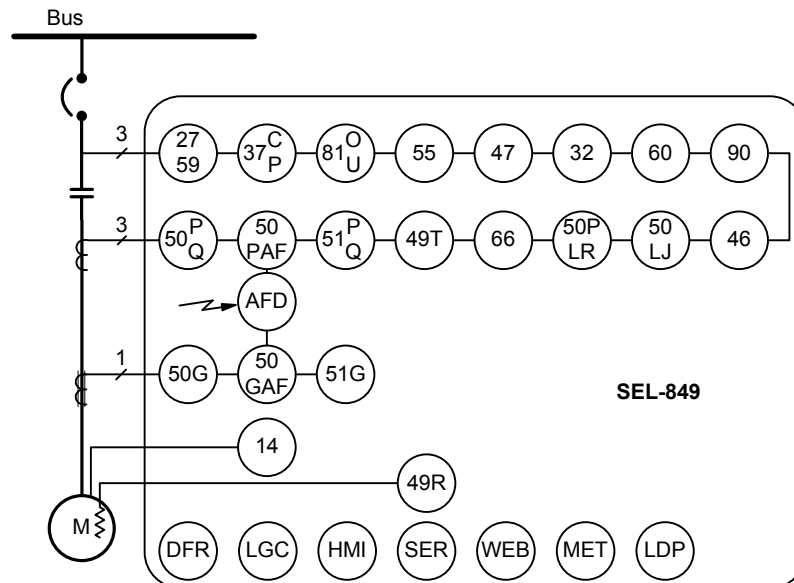

Figure 1 SEL-849 Motor Management Relay Functionality

## PROBLEM

Personnel safety is paramount for companies in industrial markets such as oil and gas, water and wastewater, metals and mining, and utilities, to name a few. These industries have continuous processes in which the power must run 24 hours per day, 7 days per week. This continuous process involves constant maintenance, monitoring, and personnel interaction with MCCs. An arc flash is a condition associated with the release of energy caused by an electric arc. The radiant energy, pressure waves, and thermal heat are known to damage hearing and eyesight and cause severe burns. The electric arc may result from many factors, such as shorting two phases, which creates a phase-to-phase fault (i.e., dropped tools, accidental contact with electrical equipment, corrosion, improper work procedures, and the buildup of conductive dust). To improve safety,

operators seek methods to reduce the incident energy exposure in the event of a flashover inside an MCC while ensuring that their product does not falsely trip.

## SEL SOLUTION

The SEL-849 and SEL-751A provide fast clearing times and added safeguards for workers. Remote communications eliminate worker exposure to arc-flash hazards. The SEL-849 communicates the state of the arc-flash detection (AFD) element to the SEL-751A via IEC 61850 Generic Object-Oriented Substation Event (GOOSE) messaging. During an arc-flash event in the motor bucket, a GOOSE message is sent upstream to the SEL-751A associated with the motor bus circuit breaker (CB). To prevent false trips, the SEL-751A must detect overcurrent and receive the AFD assertion GOOSE message from the SEL-849 to generate a high-speed trip on the motor bus CB (see the system configuration in Figure 2). This solution provides a minimum trip time of 4 milliseconds and a maximum trip time of 13 milliseconds from the application of current.

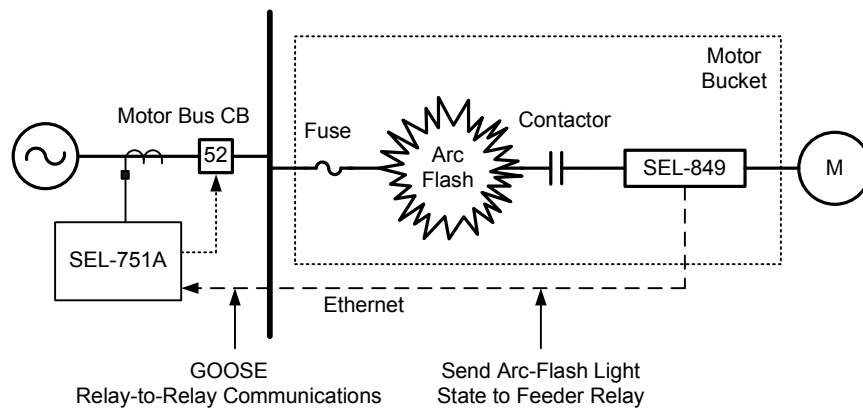

**Figure 2 Relay-to-Relay GOOSE Messaging for Arc-Flash Protection**

The SEL-751A supports peer-to-peer, real-time status and control using GOOSE with as many as 16 incoming (receive) and 8 outgoing (transmit) messages. In other words, the SEL-751A can have up to 16 SEL-849 Relays communicating via GOOSE to provide arc-flash protection to each bucket. Installation of an SEL-2730M enables communication between the SEL-751A and as many as 16 SEL-849 Relays. Figure 3 demonstrates the communications topology via Ethernet for the devices.

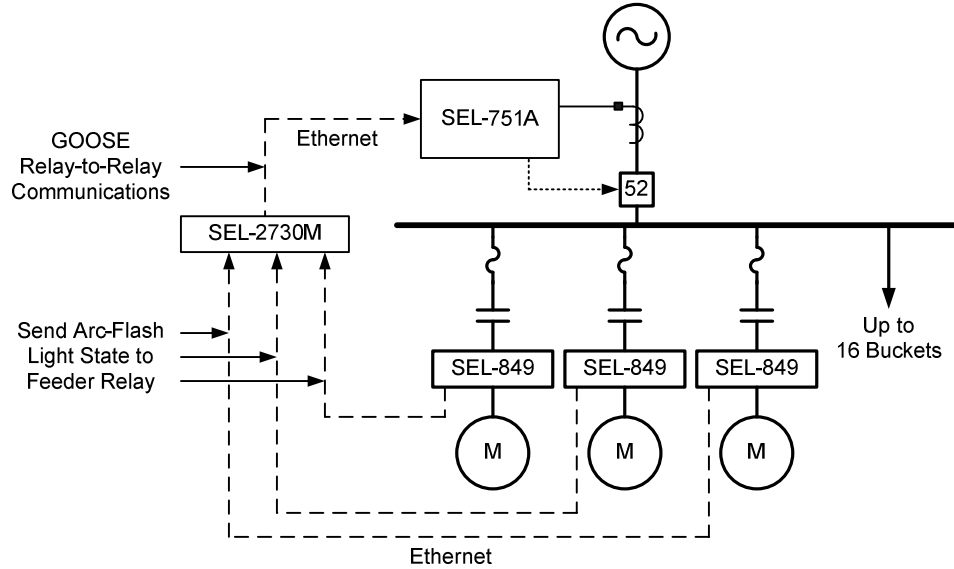

**Figure 3 Relay-to-Relay Communications Topology for Several Motor Buckets**

## CONCLUSION

This application note demonstrates how the SEL-849, SEL-751A, and the SEL-2730M provide an optimal SEL solution that is capable of reducing high-incident energy from an arc flash and able to provide arc-flash protection for an MCC in under 1 cycle. The attributes of this solution include the following:

- Up to 16 motor buckets are protected.
- False trips are prevented using concurrent overcurrent and light detection trip conditions
- AFD initiates an upstream breaker trip signal in less than 1 cycle (4 milliseconds to 13 milliseconds) from the detection of an arc-flash event inside a motor bucket.
- Ethernet communication is available among relays.

---

© 2013 by Schweitzer Engineering Laboratories, Inc.  
All rights reserved.



**SCHWEITZER ENGINEERING LABORATORIES, INC.**

2350 NE Hopkins Court • Pullman, WA 99163-5603 USA  
Tel: +1.509.332.1890 • Fax: +1.509.332.7990  
[www.selinc.com](http://www.selinc.com) • [info@selinc.com](mailto:info@selinc.com)