

SDG&E's Experience With Multiway Switchgear: Simplifying Protection and Control

Alfonso Orozco and Kawika Lawlor
San Diego Gas & Electric Company

Scott Wenke, John Hostetler, and Kamal Garg
Schweitzer Engineering Laboratories, Inc.

Presented at the
79th Annual Conference for Protective Relay Engineers
College Station, Texas
March 30–April 2, 2026

SDG&E's Experience With Multiway Switchgear: Simplifying Protection and Control

Alfonso Orozco and Kawika Lawlor, *San Diego Gas & Electric Company*
 Scott Wenke, John Hostetler, and Kamal Garg, *Schweitzer Engineering Laboratories, Inc.*

Abstract—Pad-mounted switchgear is rapidly gaining popularity in both industrial and distribution systems due to its compact design, enhanced safety features, and ease of installation. Traditionally, pad-mounted switchgear was protected using a discrete relay for each load or source way. Today, advancements in relaying capabilities allow a centralized protection and control (CPC) relay to not only protect the switchgear and load ways but also enable schemes for automatic source transfer (AST), automatic synchronization, islanding detection, and battery monitoring.

This paper will use real-world events to highlight the decade-long experience of San Diego Gas & Electric (SDG&E) implementing these schemes throughout its distribution system. Additionally, the advantages of using a single multifunction relay for protection compared to discrete relays will be discussed, including simplified maintenance, reduced costs, and improved system reliability. This paper will provide insights into how these benefits contribute to the growing adoption of pad-mounted switchgear in modern electrical systems.

I. INTRODUCTION

Pad-mounted switchgear has become an integral component of modern electric power distribution systems. Reliable uninterrupted power and reduced outage duration have driven utilities and industrial customers to adopt pad-mounted solutions. These systems provide a compact, enclosed, and fault-interrupting means of sectionalizing and protecting distribution feeders while supporting advanced protection, control, and automation functions.

Traditional distribution substations typically rely on open-air bus structures, standalone circuit breakers, and air-insulated switches. Although effective, these designs require substantial space, fencing, and maintenance and expose energized equipment to environmental risks. Pad-mounted switchgear consolidates multiple feeders and switching functions into a modular, enclosed assembly, offering safety and adequate ratings for many distribution applications at reduced footprint and cost.

For over a decade, San Diego Gas & Electric (SDG&E) has progressively moved to pad-mounted switchgear with a centralized protection and control (CPC) relay as a core element of their distribution system. This solution is being used in both distribution substations and outside-the-fence applications.

Pad-mounted switchgear is a metal-enclosed, low- to medium-voltage switching assembly designed for pad-mounted, outdoor installation on a concrete pad. These assemblies incorporate fault-interrupting devices, load breaking switches, disconnects, and integrated control cabinets housing protection and control equipment.

Switchgear is commonly configured in four-, five-, or six-way arrangements, with each “way” representing an independently controllable source, load, or tie connection. Modern pad-mounted switchgear supports a broad range of functions, including fault current interruption, current and voltage sensing, reclosing, SCADA integration, advanced protection and control logic, and support for distributed energy resources and microgrids. Fig. 1 shows a typical five-way configuration used by SDG&E today.



Fig. 1 Example of a pad-mounted switchgear cabinet used by SDG&E

II. HISTORY OF SWITCHGEAR AT SDG&E

SDG&E operates several 12 kV/4 kV substations that were originally constructed with traditional outdoor breakers and open bus work, as shown in Fig. 2 and Fig. 3. When the time came to replace this equipment, the available replacements were found to be relatively expensive for such a low-voltage application. Starting in 2005, SDG&E explored the use of pad-mounted switchgear and transformers—equipment typically deployed outside the fence—and assessed whether these could be adapted effectively for substation use. This involved evaluating the equipment across various important factors such as load switching capability, continuous load capability, fault current interruption rating, lifetime operations, number of ways, and form factor. A selection of these specifications for the SDG&E switchgear solution is shown in Section VIII for reference [1]. Once the technical evaluation met the SDG&E criteria, the next consideration that ultimately drove the decision was cost. The pad-mounted solution was less than half the estimated cost of replacing and maintaining the traditional substation equipment, which made this solution extremely appealing. Fig. 4 shows the installation after replacing the old equipment with pad-mounted equivalents, which also had the added benefit of removing exposed conductors.



Fig. 2 Older 4 kV substation equipment overhead view



Fig. 3 Older 4 kV substation equipment ground view



Fig. 4 Substation with new switchgear design

While using pad-mounted equipment met the technical requirements and cost goals, it did come with some tradeoffs. For instance, when used in a substation environment, each piece of equipment had its own 24 Vdc integrated power supply inside the cabinet rather than a shared battery bank that is more common in substations. This meant that each battery needed to be monitored individually. SDG&E implemented a battery monitoring solution that met all operational requirements and is discussed in more detail in Section IV.

Building on the success in the substation environment, SDG&E began to look at applying the solution for more typical outside-the-fence applications. Historically, SDG&E utilized load breaking switches throughout its distribution system to help isolate and sectionalize distribution circuits following a fault. However, without fault-interrupting capabilities, these solutions required the faults to be cleared by the substation breaker, disturbing service to the entire feeder. Isolation and restoration would need to occur among the load breaking switches before switching the breaker back into service, creating complex coordination schemes across many devices and limiting the number of effective fault isolation points.

After establishing that the pad-mounted switchgear could provide both switching and fault-interruption capabilities—and that its form factor was suitable for outdoor deployment—SDG&E recognized that it offered significantly greater operational flexibility. With fault-interrupting switchgear deployed outside the fence, SDG&E could still perform coordinated switching actions but now also interrupt faults throughout its distribution system, substantially improving sectionalization and restoration performance.

The original design when first implementing the switchgear solution featured both four- and five-way switches. These used a dual input overcurrent relay that could protect two ways using a single relay. A remote terminal unit (RTU) controller was used for automation functions like the battery test system described in Section IV. All components operated on 24 Vdc battery-based power supplies and battery charging was monitored through dedicated power management hardware integrated with the supply. A simplified one-line diagram is shown in Fig. 5.

This initial design worked to fulfill the basic operational goals of the switchgear deployment, but field experience began to show some shortcomings. While the dual input protection and control device met the basic requirements, it became clear additional functions like reclosing would add more value and the limited I/O did not allow the device to monitor both fault interrupter and disconnect status. Furthermore, elevated hardware failures were observed in RTU devices, leading to SDG&E seeking to improve the design and reliability.

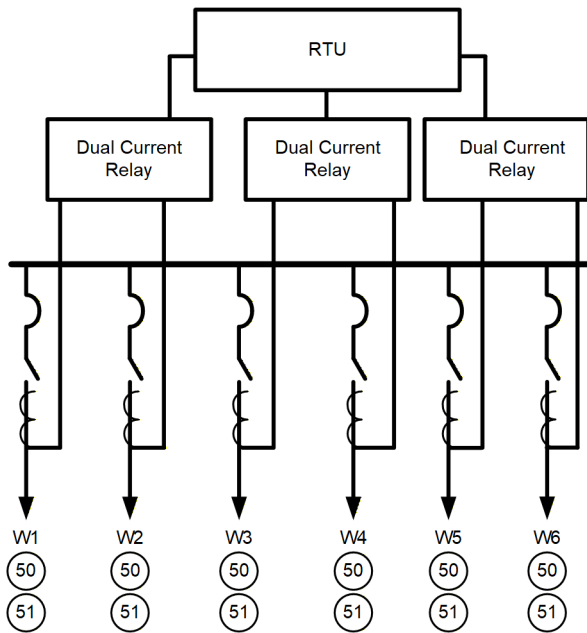

Fig. 5 Initial design with dual current relays

To improve on the design in 2012, SDG&E took a fresh look at all the products available on the market at the time. One such product was a relay [2] that had at least five three-phase current inputs, supported low-energy analog (LEA) voltage sensors, closely aligned with the pad-mounted switchgear manufacturer's design, and could fit into the local control cabinet. The device had multiple protection elements to pair with any of the current transformer (CT) inputs that matched the existing solution plus extensive automation, control, and reporting capabilities, which allowed SDG&E to move the functions from the RTU into the protective device. In total, as many as four devices could be replaced with a single CPC device to consolidate settings and increase reliability of the protection system [3]. This design, first implemented in 2012, continues to be used today in the SDG&E distribution system with more functions added over time that are discussed in Section III and Section IV.

III. SWITCHGEAR PROTECTION WITH CPC STANDARD

When transitioning to a single device for multi-way switchgear, it was important to ensure the basic protection capabilities were not compromised by the change. SDG&E improved the overall protection coverage by leveraging the protection and control functions available in the single CPC device. These functions are described in Section IV. Fig. 6 shows a typical configuration where standard functions are included on all ways, sources are on Way 1 (W1) and Way 3 (W3), and the additional optional functions are shaded.

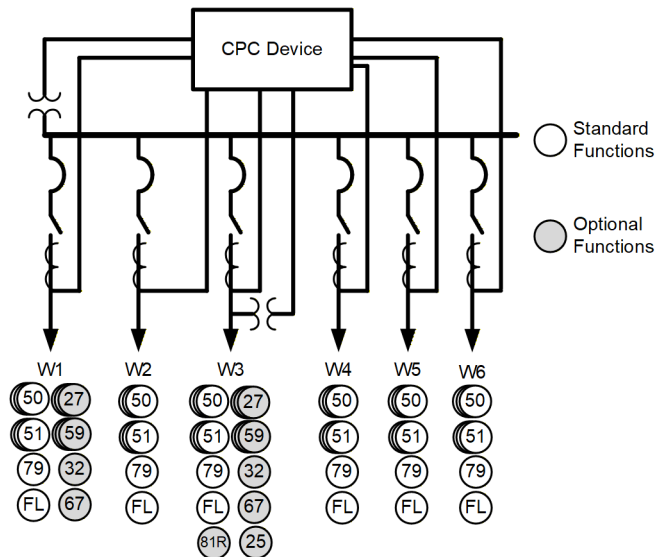

Fig. 6 Typical six-way switchgear configuration

To improve coordination and automation, this new design allows several levels of current- and voltage-based protection elements on each way. The following are details of elements in the design and their specific functions:

- Definite-time overcurrent elements (ANSI 50) – One of the most basic elements used for protection on each way is a definite-time or instantaneous overcurrent element. These elements provide fast tripping for high-magnitude fault currents where intentional time delay from inverse-time elements is undesirable. SDG&E also uses a non-tripping definite-time element as a faulted circuit indicator (FCI) for coordination schemes described in Section IV.
- Inverse-time overcurrent elements (ANSI 51) – To coordinate with fuse damage curves and other downstream devices, each way on the switchgear will need several inverse-time overcurrent elements. This allows the fault interrupters in the switchgear to be part of the broader coordination schemes with downstream switches, reclosers, and sectionalizers, enabling SDG&E to implement the protection strategies discussed in Section IV.
- Zero-sequence overcurrent (ANSI 50G/51G) – These elements are a subset of the previous elements and are implemented on all ways to improve sensitivity and selectivity of protection. Under normal conditions the amount of zero-sequence on the system is relatively low, which allows these overcurrent elements to be set to much lower levels and achieve better sensitivity compared to the phase current counterparts that must account for maximum load current.

- Negative-sequence overcurrent (ANSI 50Q/51Q) – Similar to the zero-sequence elements, negative-sequence elements can be set much more sensitively compared to phase elements. SDG&E uses negative-sequence overcurrent elements for sensitive transformer overcurrent protection. Zero-sequence elements are unsuitable for this application because zero-sequence current does not flow through transformers with delta-connected windings. In the initial design, the definite-time elements were standard for all ways, but inverse-time elements were only selectively applied to ways with a transformer due to the number of available elements.
- Reclosing (ANSI 79) – Reclosing is implemented on each way of the switchgear to automatically restore service following temporary faults. Reclosing settings are programmed on all ways to maintain consistency across devices. However, because SDG&E deploys switchgear on both overhead and underground circuits—and underground faults are almost always permanent—the reclosing function is disabled on ways serving underground cables. While reclosing is not typically done on switchgear due to the charging time for the mechanism to operate, it can be done with sufficient open interval time before closes are attempted. This can be used to restore service after a temporary fault, but pad-mounted switchgear cannot operate using the typical shot sequences in traditional reclosers.

SDG&E uses a two-shot reclosing sequence. The first shot is intended to quickly clear a momentary fault and mitigate fuse damage. A longer second shot is used to blow a fuse to provide faulted line segment isolation to minimize customer disruption. The first shot occurs a few seconds after the initial trip, while the second incorporates a long open interval of more than 40 seconds. This longer open interval is used to allow downstream devices that are not fault rated, such as sectionalizers, to operate while the system is deenergized to potentially clear downstream faults.

- Undervoltage and overvoltage (ANSI 27 and 59) – While not used directly for protection functions, under- and overvoltage elements are used in switchgear in the SDG&E system. These elements are key in source transfer schemes for critical loads as discussed in Section IV. These elements are used to detect dead-bus and live-line conditions as part of the coordinated switching scheme to alternate sources.
- Rate-of-change of frequency (ROCOF) (81R) – This element is implemented in the relay logic engine and used in applications with inverter-based resource (IBR) sources. This requirement is part of the SDG&E islanding detection scheme as described in Section IV.
- Power elements (ANSI 32) – These are also used in cases where the switchgear has an IBR source connected. The relay uses the power elements to monitor the export of power from the IBR source and

alarm or act when certain operational limits are reached.

- Fault location (FL) – A single-ended impedance-based fault location is calculated on each way following a trip condition. This feature allows crews to quickly identify how far away a fault is from the switchgear. FCI information can be used in addition to fault location to quickly determine where in the distribution system to dispatch repair crews.
- Logic engine – While not a specific function, the custom user logic was what enabled SDG&E to replace the RTU that was experiencing elevated failure rates. The CPC device featured both time deterministic logic suitable for protection or other time-sensitive applications and a separately executed logic that was suitable for automation schemes that were not time sensitive. The logic is used extensively in the schemes described in the next section and allowed SDG&E to implement custom functions not natively available in the CPC device.
- HMI controls – SDG&E makes extensive use of the front human-machine interface (HMI) on the CPC device, providing consistent indicators and controls for each way on the switchgear. This HMI gives a clear indication of status for each of the ways and simplifies operations for field personnel. In addition to controls and indication for each way, two key functions are also implemented on the front panel. The first is the ability to supervise or disable remote controls when working on the switch locally, which SDG&E labels “SUPY” in Fig. 7. When activated, no remote operation commands will be executed in the CPC device, which is critical for the safety of those working on site. The second is the ability to manually start the battery test sequence described in the next section, which is used to confirm proper operation when replacing batteries in the field. An example of an HMI for a five-way switch is shown in Fig. 7.

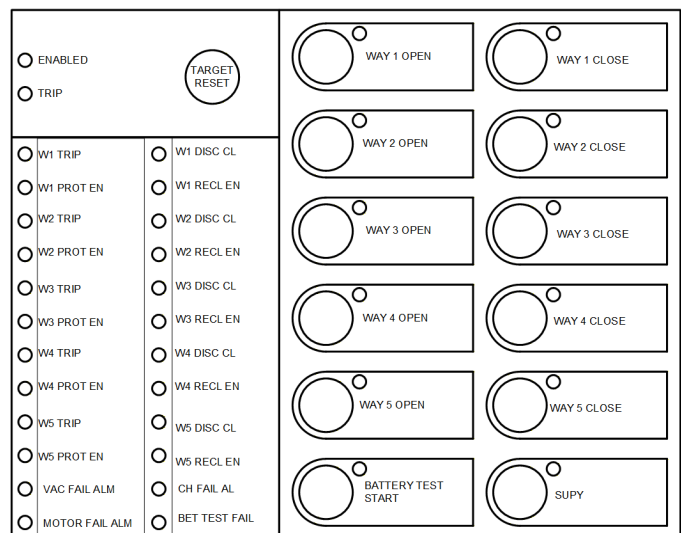

Fig. 7 Front panel of a typical five-way switch

After the initial design and deployment of the CPC scheme, the manufacturer added functions to the device. These largely augmented the existing capabilities and helped replace functions that were implemented in logic. In particular, the hardware flexibility, overcurrent protection, and reclosing capabilities were enhanced as described:

- The device allowed for a sixth current input to be used for protection, expanding the design for switches with six ways. Note that when a sixth way is added, the HMI shown in Fig. 7 is also modified with additional points for consistent design using an external module with more pushbuttons.
- Additional inverse-time overcurrent (51) elements were added that allowed SDG&E to add a negative-sequence inverse-time overcurrent element as a standard feature for all ways. Previously these were only enabled on ways with downstream transformers but, with the additional elements, SDG&E added it as a standard feature for consistency.
- Six instances of reclosing were added to the CPC device, allowing the replacement of reclosing implemented in logic. In addition, the updates to the CPC device provided features like advanced supervision, open/close failure timers, and detailed reclosing statistics.

While not a function in and of itself, one additional benefit to having a single device with all the elements described in this section is the ability to quickly modify the standard to meet operational constraints. For instance, if Way 5 (W5) needs to be used as the main a source way instead of W1 because of existing infrastructure, all that needs to change are settings in the CPC device rather than modifying wiring or creating custom panels. This flexibility saves SDG&E significant operational resources as these changes can be accomplished in a controlled setting well before being deployed in the field.

IV. SCHEMES DEPLOYED BY SDG&E

The previous section described all the elements implemented and their basic use, but over time SDG&E implemented more complex schemes to meet evolving power system needs. Once again, having all information and elements contained in a single CPC device made these schemes easier to implement because they could be coordinated within the single device or with far less devices. The schemes in question include simplified coordination, redundant source transfers on critical loads, and other applications detailed in this section.

A. Battery Testing System

As mentioned in Section II, SDG&E observed elevated failure rates with its RTU devices, so one of the chief concerns was the overall reliability of the solution. Based on the experience from 2005 to 2012, one of the largest points of failure was the power supply to the system. Consequently, periodic testing of the power supply was critical when evaluating a new standard. To actively test the power supply, a resistive load that can be connected to the power supply using an output on the CPC device is also built into each switchgear.

The CPC device also has an input that can be used to monitor the dc voltage supplied to the device. Using logic functions in the CPC device, the resistive load is connected to the battery system once a week for approximately five minutes to test the health of the batteries. If the voltage drops below 90% of nominal as measured on the CPC device during this test, the CPC device will send an alarm to operations via SCADA. To guard against false alarms, after receiving the failure a second test will be initiated remotely through SCADA to confirm the results so maintenance can be scheduled. Critically, the alarm level is set such that a failure is not imminent and the resistive load is sized to not overly stress the power supply. In the SDG&E implementation the resistor is sized to approximately 70% of power supply maximum burden of the CPC relay. This system ensures maintenance can be done in regular order instead of in an emergency fashion.

B. Automatic Restoration Schemes

Switchgear can be configured to supply redundant sources using a variety of schemes. A common topology is a loop scheme, as shown in Fig. 8, which will be used to demonstrate some common restoration schemes. The switch loop is fed using a primary source, Source 1, and an alternative source, Source 2.

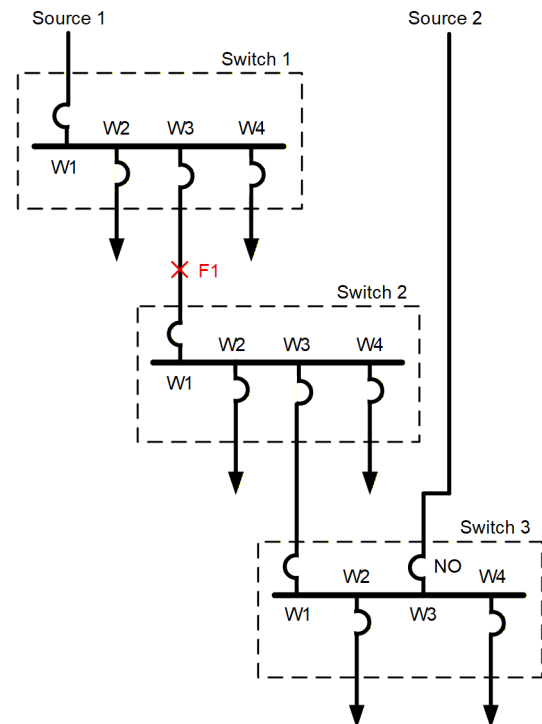

Fig. 8 Looped switchgear layout

1) Automatic Restoration Using SCADA Communication

Automatic source transfer (AST) is widely used to improve service reliability for critical loads such as airports, hospitals, and datacenters. In Fig. 8, Switch 3 is serving critical loads with AST logic enabled and ready to initiate. Once a dead-bus/live-line condition is detected on Switch 3, W1 on Switch 3 will open. Once W1 is open, W3 will automatically close to restore service to the loads on Switch 3. This process will

typically restore service within 10 seconds. The FCI status logic mentioned in Section III is used to remotely determine the fault location at F1. Following a successful trip of W3 on Switch 1, SCADA operators isolate the faulted segment by opening W1 on Switch 2. W1 on Switch 3 can then be closed remotely to restore service to Switch 2.

The primary advantages of this scheme are simplicity and the ability to standardize logic across a wide range of distribution applications. For these reasons, this is the automated restoration method commonly used by SDG&E; a detailed discussion of the implementation logic is provided in Section IV.D. A key limitation of this approach, however, is that automatic restoration is typically limited to a single switch, with additional restoration steps requiring operator intervention.

Full feeder automation can be achieved by replacing manual operator decision-making with a separate automation controller. In this configuration, the controller processes FCI status information from the CPC devices on each switch to determine fault location and executes restoration actions automatically, without requiring peer-to-peer communication between switches. While this solution is still under evaluation at SDG&E, it has been deployed by other utilities to significantly reduce restoration times [4].

2) *Automatic Restoration Without Communication*

When no SCADA or peer-to-peer communication is available, automatic restoration can be achieved by assigning each switch a unique reclose open-interval time. With proper coordination between upstream and downstream devices, only one switch will be reclosing for a given fault. Each switch infers the approximate fault location by measuring the elapsed time between upstream reclose attempts.

In the example shown in Fig. 8, Switch 1 is configured with a five-second open interval, Switch 2 with a six-second interval, and Switch 3 with a seven-second interval. A permanent fault at F1 is locked out by W3 on Switch 1 after the second reclose attempt. Switch 2 and Switch 3 identify the fault as originating upstream of Switch 2 based on the five-second interval observed between reclose attempts. After a dead-bus condition is detected following all reclose attempts, W1 on Switch 2 automatically opens to isolate the faulted segment and W3 on Switch 3 is closed to restore service from the alternate source.

Although this scheme can restore service within seconds and does not require communications infrastructure, it introduces significant engineering complexity. Careful coordination of reclosing sequences, protection settings, and custom logic is required to correctly identify fault location. Additionally, this approach is highly application-specific, requiring modifications for each installation, and becomes increasingly complex as system size and topology expand. See [5] for a more detailed discussion of this scheme.

3) *Automatic Restoration With Peer-to-Peer Communication*

When peer-to-peer communication between switches is available, faster, more advanced and robust automatic restoration schemes can be implemented. This approach

eliminates the need to infer fault location using voltage conditions, reclose counts, and open-interval timing. Instead, fault location and isolation are explicitly communicated between devices.

In this scheme, once a fault is tripped and locked out, a message is transmitted to adjacent downstream relays to isolate the faulted segment. Once isolation is confirmed, a subsequent message is sent to close the normally open tie point and restore service. A detailed discussion of this approach is provided in [6].

In the illustrated example in Fig. 8, a fault at F1 is tripped and locked out by W3 on Switch 1. The relay at Switch 1 then sends an open command to W1 on Switch 2. After W1 opens, Switch 2 sends a close command to Switch 3, which closes W3 and restores service from the alternate source.

This scheme offers several advantages including relatively simple protection settings, very fast restoration times, and excellent scalability to larger and more complex networks. The primary drawback of this approach is the requirement for dedicated peer-to-peer communication between switches that is generally expensive to deploy and maintain over large areas. This drawback makes this approach uncommon in utility distribution systems due to prohibitive costs. In contrast, peer-to-peer restoration schemes are more frequently adopted in industrial applications—such as datacenters—where spacing is short, communications infrastructure is readily available, and redundant power sources are critical.

C. *Coordination*

Coordination with protection elements, upstream devices, and downstream devices is critical to the success of any restoration scheme. The following subsections describe a few considerations associated with restoration schemes as well as switchgear operation in general.

1) *Fuse Coordination*

A fuse-saving scheme is commonly applied when coordinating inverse-time overcurrent protection with downstream fuses. The primary objective of this scheme is to interrupt fault current before thermal damage occurs to the fuse. It is estimated that 80–90% of faults on overhead distribution lines are temporary in nature [5]. By coordinating the first reclose shot with the fuse melting curve, interruption time due to momentary faults can be significantly reduced.

In typical schemes, if the fault is not cleared by the first reclose shot, a second shot with a slower inverse-time overcurrent characteristic is used to allow the fuse to operate and clear the fault. In this case, only the section of the system downstream of the blown fuse experiences a sustained outage while normal operation is restored to the remainder of the feeder. In contrast, faults on underground cables are typically permanent; reclosing is unlikely to clear the fault and instead subjects both the cable and associated switching equipment to unnecessary electrical and mechanical stress.

2) *Reducing Coordination Intervals*

At SDG&E, a coordination interval of 0.3 seconds is typically applied between fuses, load-way overcurrent protection, and source-way overcurrent protection. It is not

uncommon for six or more switches to be installed in series along a feeder, which can introduce significant challenges in maintaining adequate coordination margins. To address this, a fast bus tripping scheme may be implemented between the load ways and source way, reducing the effective coordination interval from 0.3 seconds to less than one power system cycle. This application is further simplified when using a CPC relay, eliminating the need for direct relay-to-relay communications. In such schemes, coordinating overcurrent on load ways with torque control on source ways.

When cumulative coordination intervals across multiple series-connected switches result in excessive clearing times, a high-density coordination (HDC) scheme may be employed. In an HDC scheme, selective time coordination is intentionally sacrificed; instead, closing and reclosing sequences between switches are coordinated [7]. Although this approach results in overtripping and a higher incidence of temporary outages, it ensures rapid fault clearing, effective isolation of faulted segments, and automatic restoration of service to unaffected portions of the system across a large number of devices.

3) Inrush Mitigation

Distribution feeders are also subject to line inrush, defined as the cumulative magnetizing inrush current of all transformers connected to a feeder [8]. Datacenters often employ large step-down transformers on each load-side switch position, which can result in very high inrush currents during energization. Coordinating protection in the presence of inrush presents several challenges.

The magnitude of transformer inrush current depends on factors such as residual core flux (remanence) and the point-on-wave at which the transformer is energized. Consequently, testing or relying on historical event data to characterize worst-case inrush levels is unreliable, as multiple energizations may occur before a circuit ever experiences maximum possible inrush [8]. Accurately characterizing inrush therefore requires extensive feeder-specific studies, which are costly and must be repeated for each unique circuit. Additionally, inrush currents can be extremely large, limited primarily by system impedance and transformer winding impedance. Effective inrush coordination requires the protection system to accurately identify inrush conditions, restrain/block sensitive overcurrent elements during inrush, and promptly restore normal protection once inrush has dissipated.

A traditional method for securing protection during inrush for downstream transformers is to temporarily disable fast or sensitive overcurrent elements for a predetermined time following circuit energization. During this interval, slower and less sensitive backup overcurrent protection remains active, ensuring that inrush does not result in nuisance tripping. After several seconds—once inrush is presumed to have subsided—primary overcurrent protection is re-enabled. An advantage of this approach is that the same logic can also secure protection during cold load pickup conditions. Additional benefits include simplicity and scalability; however, these advantages come at the cost of delayed fault clearing and reduced sensitivity when energizing directly onto a fault.

Second-harmonic blocking is another method for securing protection during inrush. A typical inrush waveform is shown in Fig. 9, which has even symmetry across the y-axis. Harmonic analysis of such waveforms reveals relatively high levels of even harmonics—particularly the second harmonic—when compared to the fundamental frequency component. When this condition is detected, modern relays issue blocking that can be used to torque control sensitive overcurrent elements until inrush subsides.

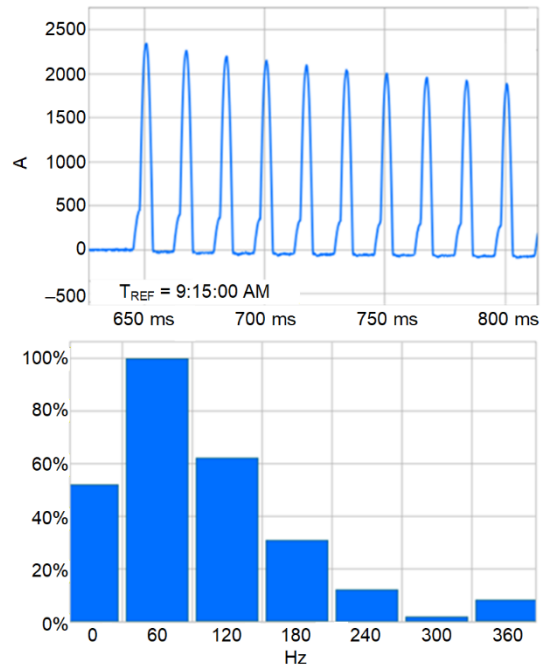

Fig. 9 Typical inrush waveform and associated harmonic content percentage

Second-harmonic blocking offers several advantages over time-based restraint. Sensitive overcurrent protection with second-harmonic blocking is inhibited only for the duration of the inrush condition, allowing primary protection to re-enable within a few cycles rather than several seconds. This significantly reduces reliance on slower backup protection. Furthermore, if a circuit is energized into a fault, the current waveform typically does not contain sufficient second-harmonic content to trigger blocking, enabling primary protection to operate immediately. Relays that support dynamic pickup and time-dial settings for inverse-time overcurrent elements can further leverage second-harmonic detection or cold load pickup indication to automatically adapt to changing network conditions in real time.

D. Automatic Source Transfer

As discussed in the previous section, SDG&E deploys switchgear in looped schemes for critical loads to provide redundant sources. While the switching described for automatic restoration is straightforward in concept, the logic required to secure the switching action against erroneous operations can be quite involved. To illustrate the SDG&E switching logic, a typical pad-mounted switchgear configuration is shown in Fig. 10.

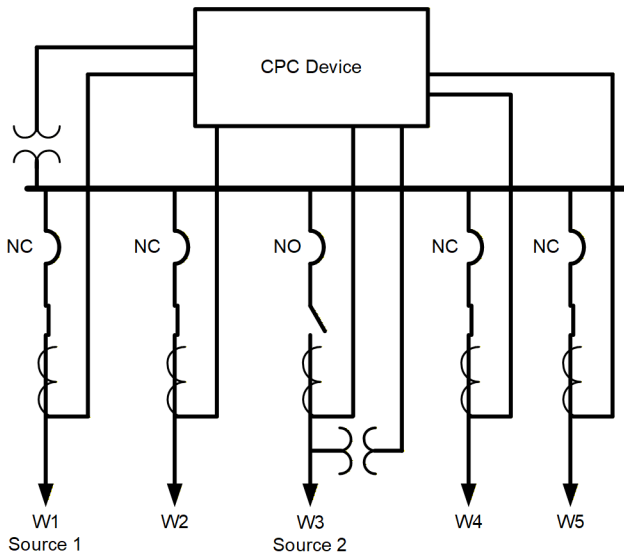

Fig. 10 SDG&E AST configuration

In this configuration, W1 is used as the primary utility source and W3 is used as an alternate source with a normally open switch. Live-line/dead-bus logic is used to supervise the automatic transfer with a three-phase potential transformer (PT) on both W3 and on the bus. In this configuration, an open transition operation [9] is used in which the primary source (W1) must be opened before the alternate source (W3) is closed. This operation has the advantage of simplicity and always having a known bus PT for voltage measurement. However, the disadvantage of this method is that there will always be momentary disruption during source transfers.

1) Automatic Source Transfer Enable

To enable the AST logic, several conditions must first be verified as shown in Fig. 11. The logic has to be armed either from SCADA or locally, the disconnect and switch status for W1 and W3 are verified to be in the correct position, and an AST cannot already be in progress. Once these verifications are satisfied, this logic is latched-in until W3 successfully closes or the logic is disarmed.

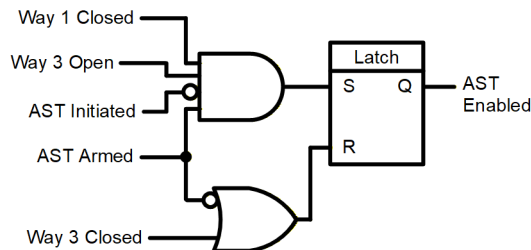

Fig. 11 Enabling logic AST

2) Automatic Source Transfer Initiate

Once enabled, the AST logic monitors for a live line/dead-bus condition between W3 and W1, respectively. A live line is declared when the line voltage on W3 exceeds 90% of nominal voltage, while a dead-bus condition is declared when the bus voltage falls below 80% of nominal. Note that these are typical thresholds, not necessarily what is used on all SDG&E installations. A security timer of ten seconds is incorporated to prevent the logic from initiating on the first reclose attempt of

an upstream device or for temporary voltage disturbances. Once the security timer is satisfied, the AST logic will be initiated until the arming is removed as shown in Fig. 12.

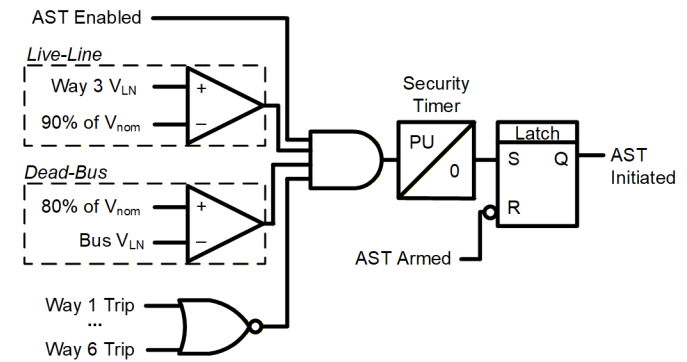

Fig. 12 AST initiation logic

3) Way Opening Logic

The way opening logic shown in Fig. 13 is common to all ways, except for the primary source way specific to the AST function. Under normal operation, when a way open command is issued—either locally or via SCADA—the logic first verifies that the way is closed using the status of the 52A contacts. It then seals in the way open indication until the way has fully opened, as confirmed by the deassertion of the 52A contact. Indications for open and close are directly programmed to contact outputs connected to the control motor circuits.

For AST, an open transition scheme [9] is utilized in which the primary source (W1) must be opened before the alternate source (W3) is closed. This means that W1 will automatically begin opening once AST is initiated as shown in Fig. 13.

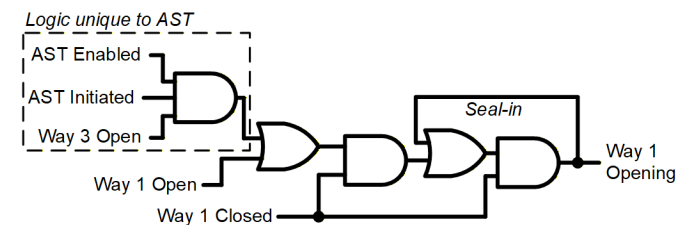

Fig. 13 W1 opening logic

4) Way Closing Logic

The way closing logic shown in Fig. 14 is common to all ways, except for the alternate source way specific to the AST function. When a way close command is issued, the logic first verifies that the way is open using the status of the 52A contacts, then seals in the way closing indication until the way has fully closed, as confirmed by the assertion of the 52A contact.

The AST logic will have already been enabled and initiated as a result of opening W1. Once the W1 open indication is received—indicated by the deassertion of its 52A contact—the W3 close logic is sealed in and remains active until W3 transitions to the closed position, verified by the assertion of its 52A contact. W3 closing completes the switchgear transfer from the primary to alternative source.

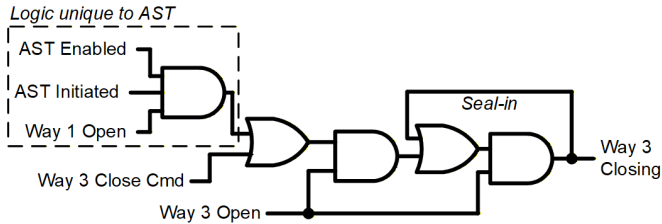

Fig. 14 Way closing logic

For SDG&E, the transfer from primary to alternate source is done automatically, but the switch back to the primary source is done manually by the operations team to avoid excessive switching operations and interruptions. Because transferring back to the primary source will cause a momentary disruption, this is coordinated with system operators to minimize customer impact.

A closed-transition operation [9] in which the alternate source (W3) must be closed before the primary source (W1) is opened can also be used. This operation requires the use of a synchronism check protection element between the bus and W3 to prevent the closing in of sources with different phase angles, frequencies, or voltage magnitudes that could damage equipment. While this approach will eliminate momentary disruption when switching in an alternative source, a disruption will still be needed when switching the primary source back in because there is no PT on W1 for synchronism check. The SDG&E approach to closed-transition operations using the switchgear configuration is further discussed in Islanding Detection.

While not used by SDG&E, the pad-mounted switchgear configuration shown in Fig. 15 is a commonly used alternative. In this configuration, a three-phase PT is located on both source ways, allowing for synchronism check supervision when transferring to an alternative source and when transferring back to the primary source. The advantage to this configuration is clear: no momentary disruptions during switching. However, the disadvantage is that there is no longer a fixed PT input for protection functions. Depending on system conditions, the PT on the primary or alternative source may be the voltage input for protection elements.

Modern relays have incorporated voltage source selection logic so that the voltage used for the protection elements on each way (e.g., directional, distance, power) can be automatically transferred between PTs. Using a breaker position indication such as breaker status contact(s) for W1 and W3, the protection elements can be directed to use whichever PT is presently connect to the bus. Voltage source selection logic allows seamless source transferring without compromising voltage dependent protection and control functions.

For relays that support synchronism check elements using single-phase PTs, another alternative configuration is possible using a three-phase PT on the bus and single-phase PTs on each source way. While this configuration is not commonly used, it allows a constant bus PT for voltage reference and seamless source transfers when restoring the primary source without the need for voltage source selection logic.

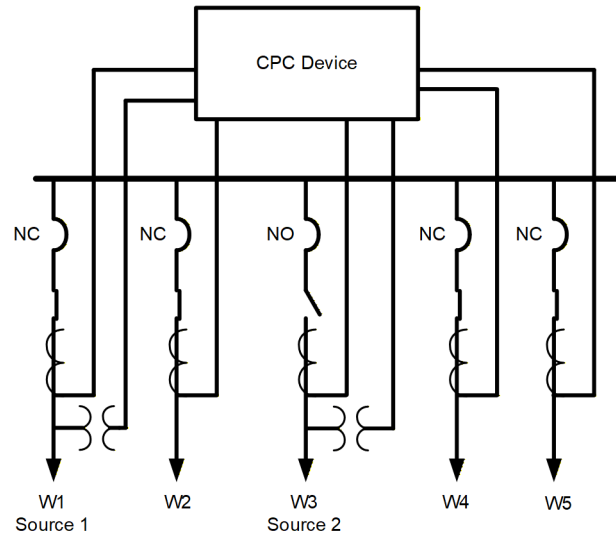

Fig. 15 Switchgear configuration with source way PTs

E. Islanding Detection

Islanding detection is a very important function for independent power producer (IPP) interconnections and microgrid operations. An important consideration for these applications is whether source islanding is desired or not. The SDG&E planning team studies system operation for both conditions and builds logic into the CPC device so that the operations team can enable or disable islanding mode for each switchgear. The logic also accounts for if the distributed energy resource (DER) source is operating as a grid-forming (GFM) or a grid-following (GFL) source. Fig. 16 and Fig. 17 show a high-level overview of how the switchgear application can operate in both islanding and parallel mode. Table 1 provides a simplified overview of GFM versus GFL operation based on [10]. A few other examples of islanding are found in [11] and [12], but this topic is beyond the scope of this paper.

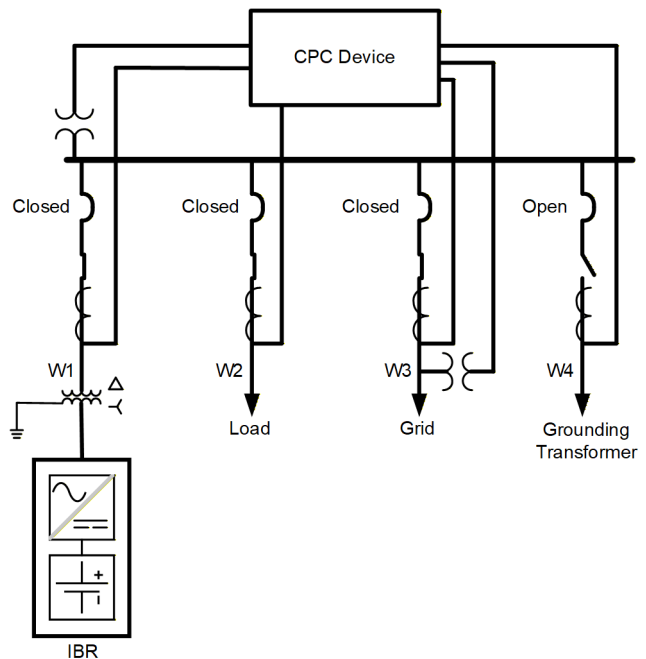

Fig. 16 Switchgear in parallel operation with W1 and W3 both closed

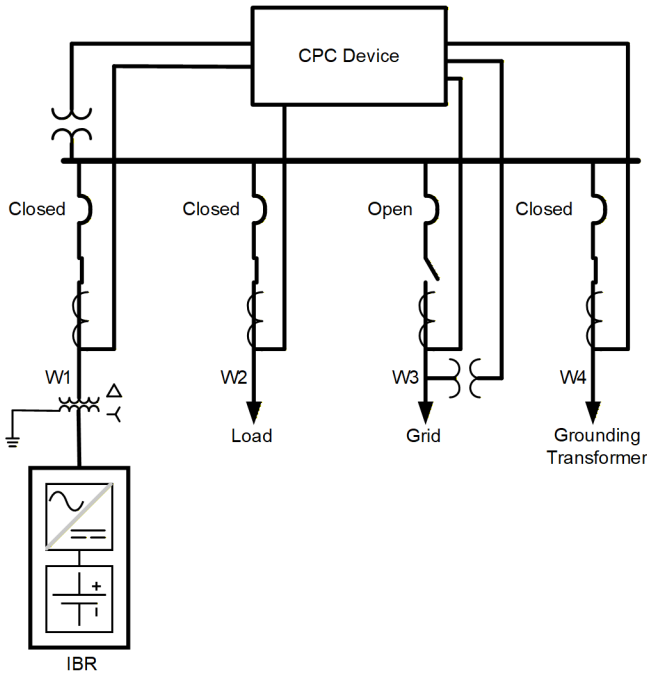

Fig. 17 Switchgear in islanding operation with W3 open

TABLE 1
COMPARING GFM VERSUS GFL IBR BEHAVIOR

GFM	GFL
Control IBR terminal voltage magnitude and angle or frequency	Control IBR current magnitude and phase angle
Do not use a phase-locked loop for synchronization	Needs phase-locked loop or equivalent
Can operate as standalone source	Dependent on grid or other resources to operate stably and provide grid support
Can operate grid at 100% IBR	Cannot operate grid at 100% GFL IBR penetration
Inherently provides fast energy injection in the inertial timeframe	Can provide fast frequency response with a short time delay needed for frequency measurement and control response
Can serve as an initial black-start resource if designed for that purpose	Cannot serve as initial black-start resource

SDG&E uses a fast ROCOF scheme in the CPC device in addition to vector shift protection in the inverter. Typical settings of 2.5 Hz/s are found to be adequate for most SDG&E applications. The deviance in frequency from nominal is calculated and compared to the ROCOF measured by the unit. Those two measurements are then calculated in a characteristic like what is shown in Fig. 18 and described in [13] and [14] to determine an island condition. The last check before an islanding trip is that an active fault is not on the system.

Fig. 16 and Fig. 17 show the typical DER application with four-way switch employed by SDG&E. There are some installations that operate similarly with five-way switches and SDG&E is exploring six-way switches. As shown in these figures, the typical configuration for a four-way switch is:

Way 1 – IBR or battery.

- Way 2 – Load/feeder.
- Way 3 – SDG&E grid connection.
- Way 4 – Grounding transformer, typically a zig-zag transformer.

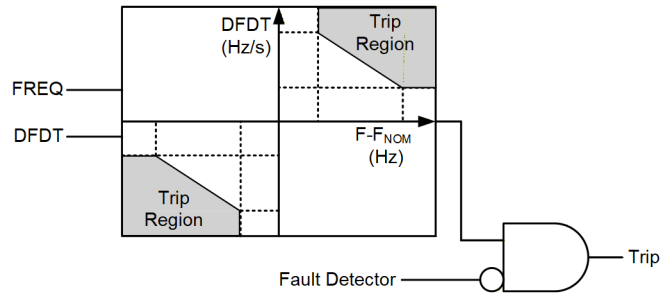

Fig. 18 ROCOF scheme

This configuration is used to match the standard shown in Fig. 6, with the IBR serving as the primary source way and the grid as alternative source. The IBR first energizes the switchgear bus before synchronizing to the grid using W3 PT. For normal grid operation, W1, Way 2 (W2), and W3 are closed and connected to the larger SDG&E grid. When connected to the grid, Way 4 (W4) is open because a grounding source is not needed.

Fig. 17 shows the configuration when islanding operation is allowed. When an island is detected using the scheme in Fig. 18, W3 is opened and the connection to the grid is lost. W4 is then closed and power is supplied by the IBR and W4 supplies a ground path for the island.

Fig. 19 shows a successful test of an islanding event in a switchgear application. The top analog trace shows the currents from the IBR source on W1, the middle analog trace shows the currents from the grid connection on W3, and the third analog trace shows the bus voltage on the switch. Below the analog traces are the binary elements in the CPC devices that show way open and closed status as well as the ROCOF element. During this test, when the grid is lost the ROCOF element asserts and the W3 is opened. This allows the IBR source to operate in islanded mode after a brief transition period and can be observed as the currents and voltages recover when the IBR becomes the GFM source.

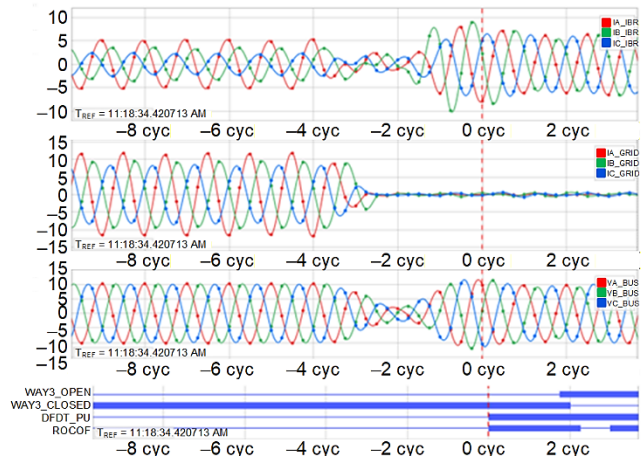

Fig. 19 Islanding operation test event

After a successful islanding operation, the circuit will eventually need to be resynchronized to the grid. To accomplish this, SDG&E employs the use of a synchronism check (ANSI 25) on the way of the switchgear with the grid connection, typically W3, to supervise a closed transition to the grid. The synchronism check scheme uses a check on the bus voltage to ensure it is within acceptable high- and low-band limits. The angle of the bus voltage is then compared to the grid voltage on the W3 PT and, once it is within ten degrees, the supervisory bit in the CPC device will allow the W3 close command to be issued. Once W3 closes, the switch is connected back to the grid to complete the closed transition process.

V. BENEFITS OF STANDARDIZATION

The previous sections have discussed the various elements available for switchgear protection and how SDG&E adapted the CPC solution to deal with new challenges. This section discusses the benefit of the CPC standard. A major goal of creating an adaptable, common solution for SDG&E was to gain the benefits of standardization. Being able to use the same solution for switches of various sizes and for all applications means that developing settings, practices, and tools becomes streamlined. Personnel become familiar with a single device and proficient at developing settings, deploying systems in the field, and troubleshooting problems over time.

A. Settings Standardization

A key aspect of streamlining the settings and engineering work is creating settings standards that can be rapidly deployed for standard applications and slightly modified when called for. One way this can be accomplished is with templating tools that many manufacturers offer, both product manufacturers and third-party integrators. In the case of SDG&E, it uses an internally developed template spreadsheet designed specifically for a single CPC device that is used across a variety of applications.

Fig. 20 shows an excerpt from the template developed by SDG&E. There are pre-defined applications in a drop-down menu and the user simply selects the application that the switchgear will be used for. This action updates the available settings and logic that are pre-populated into the device settings. Adjustments can be made to address specific circumstances for that application.

Substation :	SM	DSS 4-5 WAY	Date :	09-01-2025
Circuit :	741	DSS 4-5 WAY	SCADA	2025
Relay :		DSS 6 WAY	Supersedes :	
Part # :		S/T 4-5 WAY	Structure :	D238963
FID # :		S/T 6 WAY	RID:	SCADA 2025
		DER FAST CLOSE		
		FCP		

Fig. 20 Template with application selection

As described in Section II, one benefit of the new CPC standard for SDG&E was the flexibility of the protection functions. While the ability to adapt the solution from a standardization point of view is beneficial, this can also be detrimental because protection functions are not specified for a certain way. To help with this, the template features all of the protection and control functions described in Section III

associated with each way as shown in Fig. 21. The user populates settings to match the specific application for overcurrent pickups, time delay elements, and reclosing timers. Curve selection, torque control, and reclosing shot options use data validation and drop-down menus to ensure correct settings.

ELEMENT	I pri	I relay	I relay	Delay (cyc)
WINDING (S) IT				
Phase 50 Pickup (1)	800	6.67		
Phase 50 Pickup (2)	1201	10.010	Directional Phase 67 Pickup	10.01 3.00
Neg-Seq 50 Pickup (1)	800	6.67		
Neg-Seq 50 Pickup (2)	1202	10.020	Directional Neg-Seq 67 Picku	10.02 3.00
Ground 50 Pickup (1)	800	6.67		
Ground 50 Pickup (2)	1204	10.030	Directional Phase 67 Pickup	10.03 3.00

Phase	TOC	CURVE	TD	TORQUE
Pickup	5.01	Select Curve U1	Time Dial 1.01	Torque Control TLED_2
Neg-Seq	5.02	Select Curve U2	Time Dial 1.02	Torque Control TLED_2
Ground	5.03	Select Curve U3	Time Dial 1.03	Torque Control TLED_2

Recloser WAY 1				
Shots #	0			
Shot 1 (sec)	5			
Shot 2 (sec)	45			
Reset (sec)	120			

Fig. 21 User input section of a standard settings spreadsheet

The template file is also used to generate testing sheets for the technicians based on the specific settings applied in the template. Sheets like the one shown in Fig. 21 are dynamically configured based on the user inputs so test points are calculated directly from the settings being applied to the relay. An excerpt of the overcurrent test points is shown in Fig. 22. Test sheets being calculated directly from the template also means that modifying test points or adding others becomes trivial.

ELEMENT	I pri	I relay	I (PU)	TIME TEST	I relay	Delay	Time
WINDING (S) INSTANTANEOUS OVERCURRENT ELEMENTS							
						(cyc)	(sec)
50SP1P	800	6.67					
50SP2P	1201	10.01		67SP2D	10.01	3.00	0.05
50SQ1P	800	6.67					
50SQ2P	1202	10.02		67SQ2D	10.02	3.00	0.05
50SG1P	800	6.67					
50SG2P	1204	10.03		67SQ2D	10.03	3.00	0.05
INVERSE TIME OVERCURRENT ELEMENTS							
	TOC	CURVE	TD				
Pickup	5.01	Select Cur U1	Time Dial 1.01	I(PU) x 5	25.1	0.344	
Pickup	5.02	Select Cur U2	Time Dial 1.02	I(PU) x 5	25.1	0.436	
Pickup	5.03	Select Cur U3	Time Dial 1.03	I(PU) x 5	25.2	0.266	
Tested by :					Date :		

Fig. 22 Example of calculated test sheet

Ensuring the template is accurate is a very important exercise for utilities seeking to provide standard solutions. If there are errors in the template, they would be deployed throughout the entire system if not caught during testing. To help ensure no errors are generated by the template itself, SDG&E practices the exercise of configuring the new firmware via the template system as well as manually using the relay settings software. The output of these two methods is then reviewed and validated by the engineering team to ensure no errors were introduced from the template system.

B. Simulation and Testing Tools

Another important aspect of standardization is not only in the engineering of the relay settings but also in developing tools to help with testing. To this end, SDG&E developed a simulator, shown in Fig. 23, for the switchgear in a programmable logic controller (PLC) that simulates the switch positions and other functions built into the switchgear cabinet

for the CPC device through contact inputs and outputs. The CPC device features I/O blocks that can be removed and inserted so the PLC can be pre-wired to the blocks and replace the in-service I/O quickly. The PLC simulator is useful in a laboratory environment as a simplified hardware-in-the-loop test for new features or applications. While it does not provide the same coverage as in-depth simulations, it is a cost effective way to test for small changes to the system. The PLC simulator is also used to aid field technicians when commissioning. The PLC simulator can be used to test the CPC device in depth and can be paired with a subset of tests on the actual equipment to provide good testing coverage.

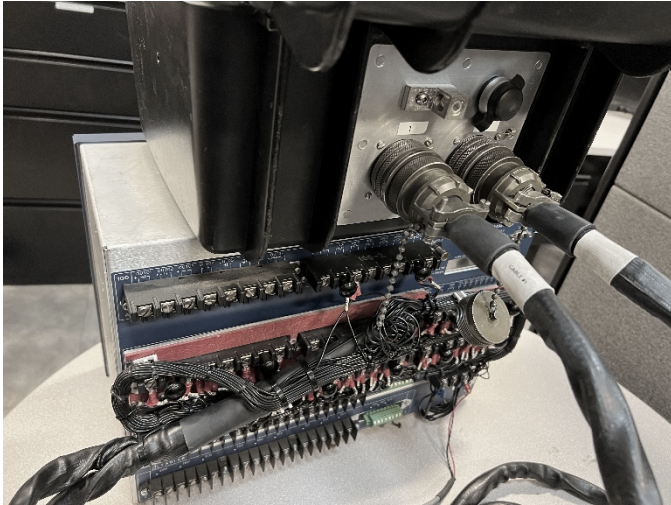

Fig. 23 CPC device and simulator with testing harness attached

The initial design of the PLC controller used toggle switches that mimicked the controls contained in the switchgear itself as shown in Fig. 24. Controls are present for all the ways and other testing functions.

Over time, this design was adopted and enhanced to use a programmable touchscreen controller. This allowed for a similar look and feel to the original toggle switches by keeping the organization of the screen identical while adding more flexibility. The updated HMI is shown in Fig. 25.



Fig. 24 PLC control panel with toggle switches

The tools discussed in this section show the benefits that come from standardization of a switchgear solution. Not only can it be adapted to meet new challenges in the SDG&E

distribution system, it can also increase organizational efficiency in engineering and field operations.



Fig. 25 PLC control panel on touchscreen

VI. FIELD RESULTS

The previous sections explain the benefits SDG&E have experienced by moving to a CPC type solution for their switchgear standard. This section discusses the performance of the solution.

As described in Section II, SDG&E first implemented the switchgear scheme in 2005 and has been using the CPC version of the solution since 2012. Since 2012, SDG&E has deployed over 1000 switchgear installations with the CPC device with no notable field failures. There have been units that required preemptive maintenance, such as for failed battery tests, but this maintenance was minimally disruptive because it was completed during regularly scheduled operations.

A key part of the solution is the additional schemes added over time as outlined in Section IV. These additional schemes have allowed SDG&E to continue using the same standard for over a decade and still adapt to new challenges like the introduction of additional IBR sources. An important aspect of these schemes is that, because the core CPC device has remained unchanged since 2012, the new features are not only deployed on the newest installations but older, existing units also benefited without any firmware upgrades or additional equipment needed. Instead, settings and logic that had been validated by the engineering team were loaded into the older devices during planned maintenance to add the new functions. This flexibility allows SDG&E to adapt standards in newer devices and retroactively add new functions. It provides confidence that the existing standard will be able to meet present and future challenges moving forward.

As mentioned in Section II, a key aspect of SDG&E choosing to pursue the switchgear solution broadly was to add more fault-interrupting capability to the distribution system. While this capability increases the overall reliability of the system by providing additional granularity in fault isolation, it is important that the solution performs when called upon. Typically, over 100 faults will occur each year across all deployed devices on the distribution system for various reasons

including wildlife, weather-related issues, or vegetation contact. The switchgear containing the CPC solution has operated many hundreds of times collectively to protect the primary equipment and successfully restore service.

VII. CONCLUSION

Pad-mounted switchgear provides a compact, cost-effective solution for distribution protection. SDG&E has been using fault-interrupting switchgear successfully for over 20 years and the latest CPC-based protection and control standard for over 12 years with great success. The CPC solution provides all the needed protection and control in a single device that can be scaled from switches with four- to six-way applications. In addition, SDG&E has benefitted from the standardization of their solution, developing tools to increase the efficiency of engineering and operations. SDG&E has experienced good results with a track record of reliability and dependability that give confidence that the solution will continue to perform well. Because of the adaptability of the solution to new applications, SDG&E is confident that its standard will continue to serve well and meet future requirements.

VIII. APPENDIX

TABLE 2
SAMPLE SPECIFICATIONS FROM SWITCHGEAR

Device	Load Breaking Switch	Vacuum Fault Interrupter
Basic Insulation Level Phase-to-Phase, Phase to Ground	110 kV	110 kV
Basic Insulation Level Across Open Contacts	110 kV	110 kV
One Minute Withstand	34 kV	34 kV
Continuous Current	630 A	630 A
Load Switching	630 A	630 A
Peak Current	41.6 kA	41.6 kA
Load Break Operations at Full Load	5000	N/A
Maximum Emergency Three-Time Interrupting	2000 A	N/A
Number of Fault Interruptions at 16 kA	N/A	65
Short Time Withstand (1 s) Symmetrical	16 kA	16 kA
Short Time Withstand (1 s) Asymmetrical	25.6 kA	25.6 kA

IX. REFERENCES

- [1] Trayer Engineering Corporation, "Medium Voltage Padmount Switchgear SD3800 Series Solid Dielectric Insulated Vacuum Fault Interrupter." Available: <https://trayer.com/wp-content/uploads/Solid-Dielectric-3800-Padmount-VFI-with-VD-March-27-2018.pdf>.
- [2] *SEL-487E Transformer Protection Relay Instruction Manual*. Available: selinc.com.
- [3] J. Byerly, M. Thakur, J. Hostetler, C. Burger, and S. Wenke, "Distribution Digital Substation—Consolidated Protection and Digital Secondary Systems," proceedings of the 50th Annual Western Protective Relay Conference, Spokane, WA, October 2023.
- [4] G&W Electric, "Case Study: Industrial Feeder Restoration," September 2019. Available: <https://www.gwelectric.com/wp-content/uploads/2019/09/GWCS27-2019-Industrial-Feeder-Restoration.pdf>.
- [5] J. Blair, G. Hataway, and T. Mattson, "Solutions to Common Distribution Protection Challenges," proceedings of the 2018 IEEE Rural Electric Power Conference, Memphis, TN, May 2018.
- [6] G. Hataway, T. Warren, and C. Stephens, "Implementation of a High-Speed Distribution Network Reconfiguration Scheme," proceedings of the 32nd Annual Western Protective Relay Conference, Spokane, WA, October 2005.
- [7] J. Thorne, D. Nahay, C. Salo, J. Blair, and G. Ashokkumar, "Improving Distribution System Reliability With High-Density Coordination and Automatic System Restoration," proceedings of the 49th Annual Western Protective Relay Conference, Spokane, WA, October 2022.
- [8] L. Wright and L. Ayers, "Mitigation of Undesired Operation of Recloser Controls Due to Distribution Line Inrush," proceedings of the 2015 IEEE Rural Electric Power Conference, Asheville, NC, April 2015.
- [9] R. Shah, S. N. Ananthan, P. Patel, and W. S. Reed, "A Practical Guide: Design and Protection Considerations for Developing Reliable Automatic Transfer Schemes (ATSs)," proceedings of the 51st Annual Western Protective Relay Conference, Spokane, WA, October 2024.
- [10] M. Patel, S. Brahma, N. Fisher, S. Li, and K. Garg, "Power System Protection for IBR Dominated Grid," 2025 IEEE PES General Meeting Tutorials, July 2025.
- [11] E. Revi, G. Wegh, S. Hollis, A. Abd-Elkader, F. Amuna, and R. Vo, "Grid-Parallel and Islanding Operation Challenges of a Large Battery Energy Storage System at Cape Cod," proceedings of the 76th Annual Georgia Tech Protective Relaying Conference, Atlanta, GA, May 2023.
- [12] H. Magnago, M. Baker, D. Nobles, M. Aubuchon, E. Herman, S. Manson, L. Cevello, and F. Calero, "Hardware-in-the-Loop Simulation, Control, and Validation of Battery Inverter Characteristics Through the IBR Control Hardware," proceedings of the 49th Annual Western Protective Relay Conference, Spokane, WA, October 2022.
- [13] K. G. Ravikumar, A. Upreti, and A. Nagarajan, "State-of-the-Art Islanding Detection and Decoupling Systems for Utility and Industrial Power Systems," proceedings of the 69th Annual Georgia Tech Protective Relaying Conference, Atlanta, GA, April–May 2015.
- [14] M. Donolo, A. Guzmán, V. Mynam, and B. Dull, "Aurora Mitigation Using the SEL-751A Relay," SEL Application Guide (AG2010-03), 2010. Available: selinc.com.

X. BIOGRAPHIES

Alfonso Orozco received his B.S. in electrical engineering with a power emphasis from Cal Poly Pomona and a master's degree from the University of Southern California. Prior to joining San Diego Gas & Electric (SDG&E) in 2002, Alfonso worked at Rockwell Automation as field support automation engineer and Southern California Edison as an apparatus and power quality engineer. At SDG&E, he has worked as relay testing supervisor, grip operations as principal engineer, system protection as protection and automation principal engineer, and supervisor with emphasis on advance technology integration.

Kawika Lawlor was born and raised in San Diego and earned both his bachelor's and master's degrees in power systems engineering from Arizona State University. He began his career at Arizona Public Service (APS) as a rotational engineer, gaining experience in grid operations, generator protection and testing, substation design, and apparatus engineering before being placed in grid operations. He later returned to San Diego to join San Diego Gas & Electric (SDG&E) as a senior engineer in grid operations engineering. Kawika moved into leadership and held various leadership roles in grid operations before he transitioned into his current role as system protection manager.

Scott Wenke received his B.S. in electrical engineering with a power emphasis from Washington State University. Prior to joining Schweitzer Engineering Laboratories, Inc. (SEL) in 2013, Scott worked at Itron. At SEL, he is a product manager in the Power Systems group of Research and Development and is responsible for transmission and substation product lines.

John Hostetler received his B.S. in electrical engineering from Washington State University in 2011 and his master's of engineering degree in electrical engineering from the University of Idaho in 2020. Prior to joining Schweitzer Engineering Laboratories, Inc. (SEL) in 2011, John worked at Snohomish County Public Utility District. At SEL he works as a senior product engineer in the research and development division.

Kamal Garg received his B.S.E.E. from Kamla Nehru Institute of Technology, Avadh University, India and his M.S.E.E. from Florida International University and India Institute of Technology, Roorkee, India. Kamal worked for POWERGRID India and Black & Veatch for several years in various positions before joining Schweitzer Engineering Laboratories, Inc. (SEL) in 2006. Presently, he is a principal protection engineer at SEL Engineering Services, Inc. (SEL ES). Kamal has experience in protection system design, system planning, substation design, operation, remedial action schemes, synchrophasors, testing, and maintenance. Kamal is a licensed professional engineer in the U.S. and Canada and a member of IEEE.