



# 2026 Product and Solution Guide





## New and Upcoming Products

SEL-9L Line Relay	17
LINAM® UGFI Underground Fault Indicator	37
SEL-T35 Time-Domain Power Monitor	41
SEL-2414 Transformer Automation Controller	44
SEL-2743 Ethernet Switch	52
SEL-2744 Ethernet Switch	52
SEL-3790 Low-Voltage Divider Module	67

## Contents

About SEL	2
SEL Innovations and Solutions	6
Generator Protection	8
Industrial and Commercial Protection	12
Transmission Line Protection and Fault Locating	16
Substation Protection	22
Distribution Protection and Control	28
Fault Indicators, Sensors, and CTs	34
Metering and Power Monitoring	38
Automation and Computing Platforms	42
SEL Network Communications Solutions	48
WAN and LAN Networks	50
Wireless Communications	54
Precise Time	56
Transceivers and Adapters	58
Cables	60
Remote I/O	62
Annunciation and Notification	63
Software	64
Accessories and Tools	67
Panels and Enclosures	68
Direct-Replacement Assemblies	69
SEL Services	70
Project and Program Management	71
Microgrids and Power Management	72
Cyber Services	73
Education and Training	74
Ordering and Customer Support	76
Index	78

**Our Mission: Making Electric Power Safer, More Reliable, and More Economical**

SEL invents, designs, manufactures, and supports a complete line of products and services for the protection, monitoring, control, automation, and metering of electric power systems.

Our solutions range from comprehensive generator and transmission protection to distribution automation and control systems.

Our Engineering Services division partners with customers globally to create turnkey solutions and services that help protect and control critical electrical infrastructure worldwide. We also offer education and full product support.

SEL products are in more than 170 countries and support industries from petrochemical to transportation to electric utilities.







Dr. Edmund O. Schweitzer, III  
 Inventor of the world's-first digital  
 protective relay—the SEL-21.

### Looking Back, Moving Forward

SEL Founder and Chairman of the Board Dr. Edmund O. Schweitzer, III, invented the first microprocessor-based digital protective relay, the SEL-21, in 1982. The SEL-21 revolutionized the electric power industry by providing reliable transmission line protection with fault locating at a much lower cost than traditional electromechanical relays.

In the decades since, SEL has launched power industry innovations including the load-encroachment element in a transmission relay, synchrophasors as a standard feature in protective relays, and MIRRORING BITS® relay-to-relay communications.

### 2020

We added the SEL-T401L Ultra-High-Speed Line Relay to our family of protective relays, automation controllers, digital secondary system solutions, recloser controls, and more. The SEL-T401L is the first relay in the world to combine traveling-wave and incremental-quantity elements with phasor-based protection.

### 2021

We released our newest overcurrent protective relay, the SEL-851 Feeder Protection Relay, as well as our operational technology (OT) application platform, Blueframe®, and its first application suite, SEL Device Management and Automation (DMA).

### 2022

We introduced the SEL Axion® Bay Controller and SEL Fault Location, Isolation, and Service Restoration (FLISR), a wide-area control application that operates on our Blueframe application platform to locate and isolate faults and automatically restore power to healthy portions of affected lines or feeders.

### 2023

We made major enhancements to our IEC 61850-based solutions, including a new gigabit Ethernet card for SEL-400 series relays and Parallel Redundancy Protocol (PRP) support for Sampled Values (SV)-based process bus applications.

### Industries We Serve

- Electric power generation
- Power transmission and distribution
- Oil, gas, and petrochemical
- Renewable energy
- Metals and mining
- Water and wastewater
- Pulp and paper
- Mission-critical power systems
- Government
- Education and healthcare
- Consumer product manufacturing
- Transportation
- Data centers
- Land mobile radio systems

### 2024

We released the SEL-TWFL Dual Traveling-Wave Fault Locator and 12-Channel MHz Recorder, which locates faults to within one tower span and monitors up to two transmission lines from a single substation.

### 2025

We introduced the SEL-T35 Time-Domain Power Monitor, which continuously streams time-synchronized waveform oscillography and industry-exclusive energy packets. We also released the LINAM® UGFI Underground Fault Indicator, which streamlines underground fault locating and offers industry-leading adjacent-phase immunity.

## Quality in Manufacturing

We design and manufacture all our electronic devices in the U.S.A. This allows for direct collaboration and short feedback loops between our research and development and manufacturing divisions as well as world-class supply chain security. We manufacture our own critical components, like metal cabinets, printed circuit boards (PCBs), and magnetic devices, in our secure, SEL-owned and -operated facilities in Washington, Idaho, Illinois, and Indiana.

SEL exceeds industry quality standards, requirements, and customer expectations. We test our products thoroughly and verify that they will perform under demanding and harsh conditions.

Our quality practices include:

- Monitoring and controlling processes to exceed the ISO 9001:2015 Quality Management Systems Standard.
- Developing robust, repeatable, and scalable manufacturing processes to address process errors.
- Ensuring that our test and calibration laboratories use the latest equipment and follow National Institute of Standards and Technology (NIST) traceable standards for accuracy and maintenance.
- Partnering with our suppliers for the highest possible quality and value.



“As an engineering company, we work every day to invent, design, and support products that monitor, control, and protect power systems installed all over the world. Serving our industry is a tremendous privilege and responsibility that we take very seriously. Listening to our customers’ requirements and needs, we strive to make our solutions innovative, reliable, easy to use, and secure. We invest in our people, tools, and facilities in order to produce designs that exceed our customers’ requirements. Engineering is our middle name, and it’s what we love to do.”

**Dave Whitehead**  
President

---

## Warranty, Service, and Support

We back our products with a ten-year warranty, no-charge diagnostic and repair services, local support, and a variety of test procedures and certifications.

Our dedicated support teams are located in regional offices around the globe and staffed with SEL application engineers who are experts in our products and in power system applications. We offer free, 24/7 emergency technical support for the life of your SEL products.

Many support questions may also be answered by visiting our video portal at [video.selinc.com](http://video.selinc.com), where you’ll find how-to and support videos ranging from product set up and configuration to report retrieval and resource management.

## Learn More

Read more about our history, products, and practices at [selinc.com/company/about](http://selinc.com/company/about).

## **Traveling-Wave and Time-Domain Technologies**

- Protection that isn't dependent on sources; great for areas with high inverter-based resource integration.
- Detects and issues trip commands in 1–2 ms, 5–10 times faster than traditional protection.
- The most accurate fault locator available; pinpoints faults to within one tower span.

## **Software-Defined Networking**

- The only engineered network designed for reliable control system operations.
- Ensures traffic only flows between designated points and blocks all other traffic, eliminating the need for complex firewall rules.
- Redirects network traffic to alternate paths in under 100  $\mu$ s when the network breaks.

## **SEL POWERMAX® Power Management and Microgrid Control Solutions**

- Maximizes uptime by controlling generation, shedding loads, and automatically synchronizing microgrids.
- Scalable from oil refineries to solar and wind farms to managing an entire country's power system.
- Manages energy costs and determines the optimal generation dispatch based on operational conditions.

## **SEL Arc Sense™ Technology for Wildfire Mitigation**

- Detects and isolates high-impedance downed conductors to reduce fire risk while keeping unaffected line sections energized.
- Alerts operators of a fallen conductor or instructs circuit breakers or recloser controls to isolate the affected circuit.
- Available in many devices already deployed in your distribution systems.

## **Time-Domain Power Monitoring With Energy Packet Technology**

- Streams continuous waveform data to SEL Synchrowave® software, which captures, analyzes, and stores every disturbance.
- Accurately measures energy transfer every millisecond, regardless of the waveshape, frequency, or phase.
- Calculates energy in a simple method that is traceable to the fundamentals of physics and mathematics.

## **SEL Time-Domain Link (TiDL®) Technology**

- The simplest, most reliable, and lowest-cost digital secondary system available.
- Plug-and-operate configuration.
- Requires no network switches or clocks.

## **SEL ICON® Virtual Synchronous Networking**

- Packet transport with deterministic time-division multiplexing (TDM) and better than 1 ms latency.
- Enables TDM-based line current differential protection within IP core networks.
- Allows packet-based and TDM-based systems to work together, greatly reducing communications migration or upgrade costs.

## **SEL Arc-Flash Solutions**

- Life-saving arc-flash protection operates in milliseconds to reduce arc fault energy.
- Combines light sensing with fast overcurrent protection to provide high-speed detection without operating for external faults.
- Works with low- and medium-voltage switchgear and easily coordinates with other devices in industrial- and commercial-scale facilities.

## **SEL-487E Centralized Protection and Control**

- Simplifies commissioning, testing, firmware management, and cybersecurity while reducing the total cost of ownership.
- Built on a proven relay platform.
- Offers flexible deployment solutions, including traditional I/O connections, SEL TiDL, or IEC 61850.

### **SEL-5702 Synchrowave Operations Software**

- Wide-Area Situational Awareness (WASA) software that aggregates time-series data, including synchrophasor data, relay event reports, and high-resolution waveform streams.
- Equips transmission control centers with tools to transform time-synchronized data into detailed system insights that support decision making.
- Simple to use and customizable to maximize WASA.

### **Blueframe® Device Management and Automation (DMA)**

- Automatically collects, stores, and manages device-specific information to simplify system-wide device management and compliance.
- Automates the collection of oscillography, Sequence of Events data, device settings, property information, and other data.
- Rotates passwords and streamlines device audits with summary reports that identify device changes.

### **Blueframe FLISR (Fault Location, Isolation, and Service Restoration)**

- Enables you to create system configurations in minutes with no complex modeling required.
- Manages protection and switching devices at the grid edge, increasing the speed of service restoration.
- Manufacturer-agnostic recloser support through DNP3.

### **High-Density Coordination™ Solutions for Distribution Protection and Reclosing**

- Simplify recloser deployment in any feeder topology, overcoming the limitations of traditional time-overcurrent coordination.
- Coordinate the actions of any number of SEL-651R Advanced Recloser Controls, allowing all of them to operate quickly, securely, and dependably.
- Implement with your existing communications infrastructure—or even without communications.

### **SEL-RPM Redundant Power Module**

- A reliable and simple multisource module to power your protection, monitoring, and control equipment.
- Combines as many as three ac sources and one dc source for dependable control power during normal operations and power disturbances.
- Keeps protection, automation, and SCADA running and increases device availability, even during station battery servicing and station power interruptions.

### **SEL Grid Configurator Software**

- Provides context-oriented configuration and commissioning tools for SEL power system devices.
- Facilitates device testing and commissioning through customized HMI dashboards.
- Simplifies settings evaluation with intuitive comparison interfaces.

### **ACSELERATOR Architect® SEL-5032 Software**

- Provides powerful and simple IEC 61850 configuration.
- Efficiently supports a top-down engineering workflow in the role of the IED Configuration Tool (ICT).
- Innovative interoperability features include the ability to create a custom IED data model and the ability to use multiple IEC 61850 editions in the same system.



# Generator Protection

[selinc.com/products/categories/protective-relays/#generator-protection](http://selinc.com/products/categories/protective-relays/#generator-protection)

Modern generators and related equipment require advanced protection, automation, control, metering, and security. SEL products and solutions, including engineering services, address any nameplate rating from megawatt to kilowatt and range from wide-area protection systems down to utility-scale generation and microgrids.

## Applications

- Hydropower
- Steam and thermal generation
- Combustion and combined-cycle generation
- Wind power
- Solar power
- Nuclear
- Power management (POWERMAX®)
- Microgrids
- Remedial action schemes/ special protection systems
- Electrical balance-of-plant



## Customer Story

Belgium Integrates Offshore Wind Power Into European Grid  
[selinc.com/featured-stories/elia](http://selinc.com/featured-stories/elia)

## Example System Diagram

Combine SEL generator protective relays with other SEL automation, monitoring, and control products for a comprehensive solution.

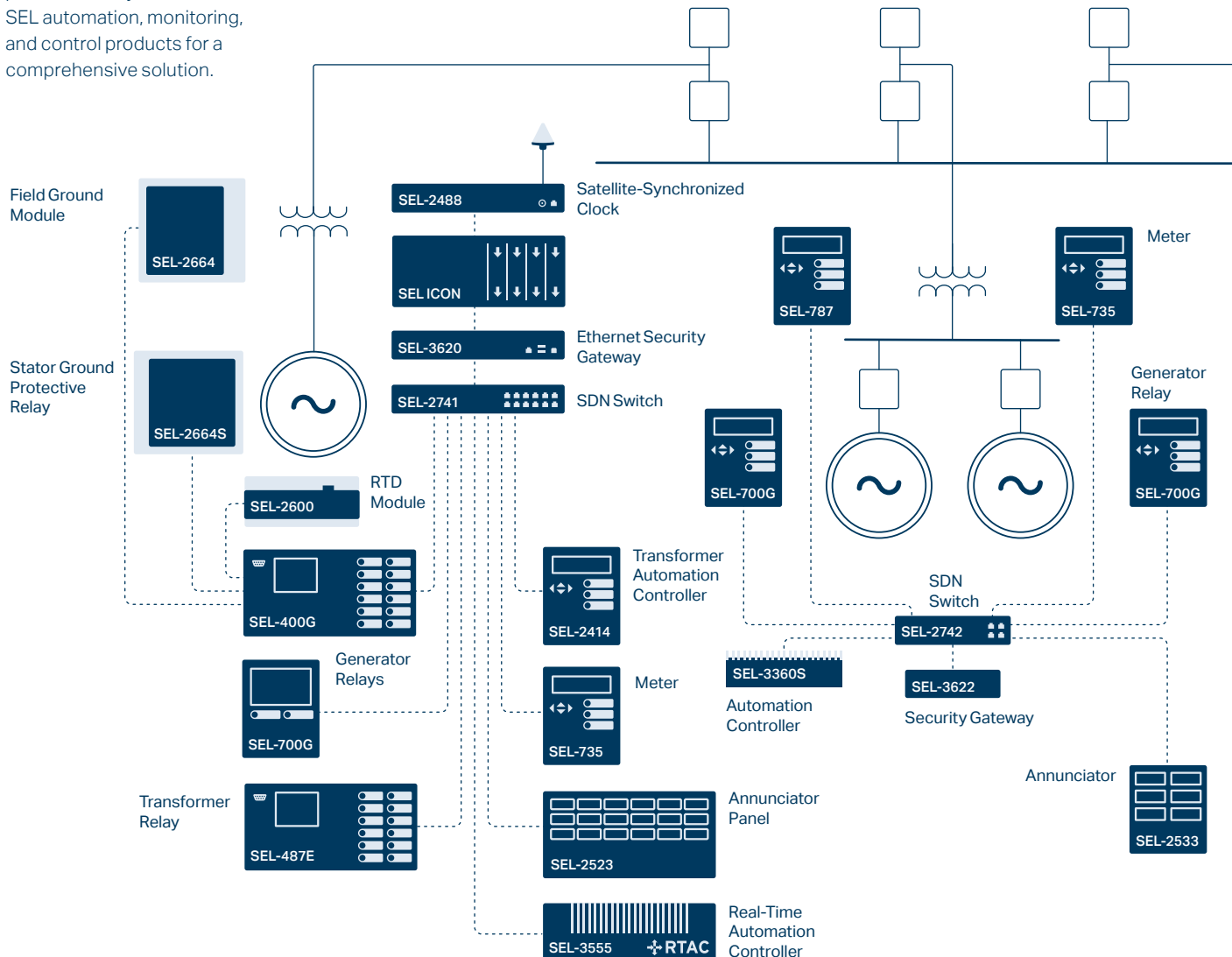

## Webinar

Protection Advancements to Benefit Generators of All Sizes and Types

[selinc.com/events/on-demand-webinar/130607](http://selinc.com/events/on-demand-webinar/130607)

## Related Material

POWERMAX Solutions

[selinc.com/api/download/blt1d488719cce3a781/?lang=en-us](http://selinc.com/api/download/blt1d488719cce3a781/?lang=en-us)

## Technical Papers

Fast Wind Farm Restoration Using Wireless Fault Sensors to Identify Faulted Segments

[selinc.com/api/download/130379](http://selinc.com/api/download/130379)

Leveraging Digital Relays for Protection of Pumped Storage Hydro

[selinc.com/api/download/121666](http://selinc.com/api/download/121666)

Capability Curve-Based Generator Protection Minimizes Generator Stress and Maintains Power System Stability

[selinc.com/api/download/124333](http://selinc.com/api/download/124333)

Stator Ground Protection for Multiple High-Impedance Grounded Generators Sharing a Common Bus

[selinc.com/api/download/124321](http://selinc.com/api/download/124321)

Upgrading PacifiCorp's Jim Bridger RAS to Include Wind Generation

[selinc.com/api/download/135500](http://selinc.com/api/download/135500)

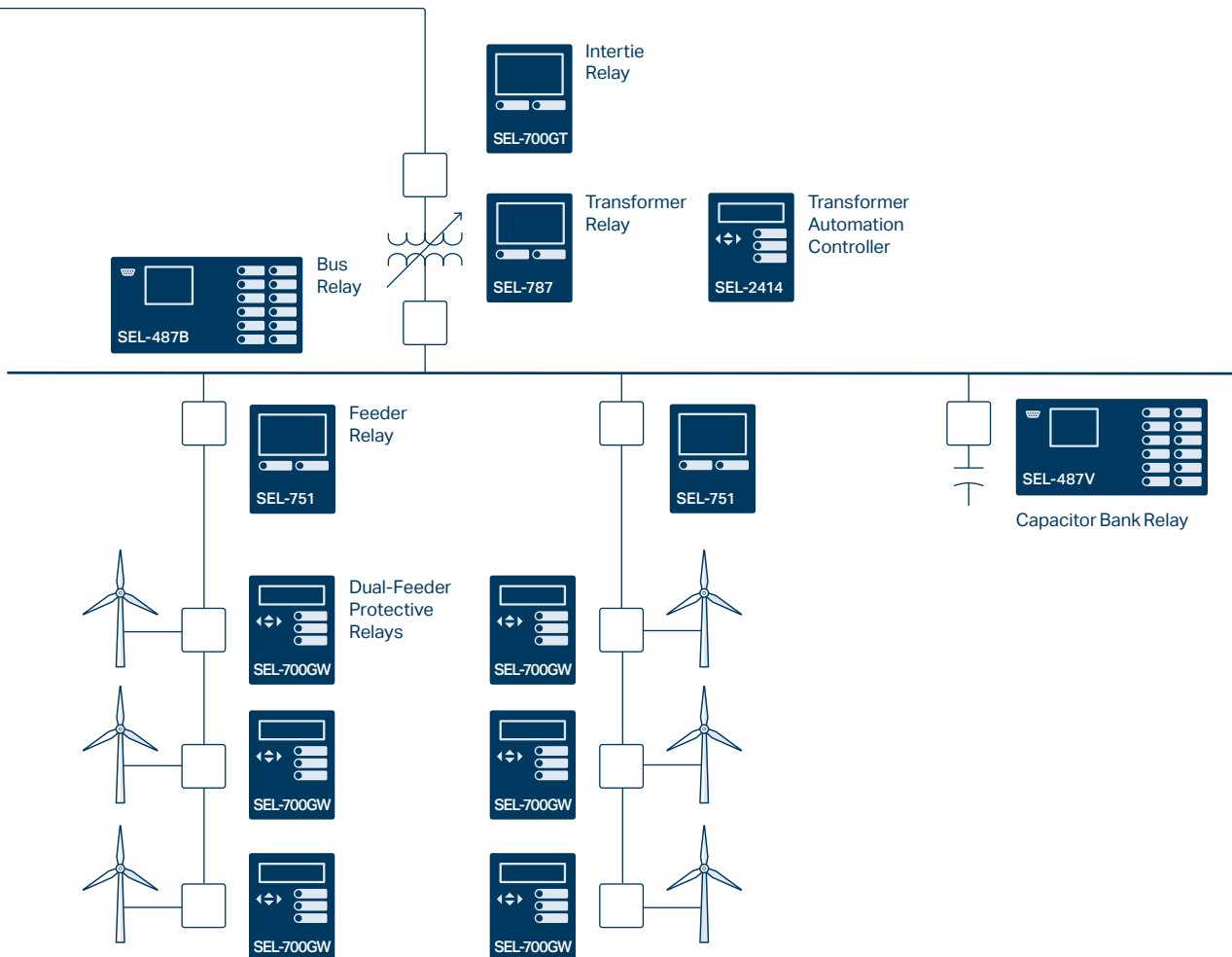



### SEL-400G Advanced Generator Protection System

Combine generator, bus, and step-up transformer protection in one package, and achieve comprehensive protection and monitoring for generators of all types and sizes, including those used in pumped-storage applications.



### SEL-700G Generator Protection Relay

Provide generator or unit protection in utility, industrial, and renewable applications with the flexible I/O and functionality of the compact, economical SEL-700G.



### SEL-300G Generator Relay

Implement primary and backup protection for utility and industrial generators.



### SEL-2664S Stator Ground Protection Relay

Protect high-impedance grounded generators from ground faults at standstill, during startup, and while running. All SEL-2664S relays are sold with the SEL-4664 Calibration Module.



### SEL-2664 Field Ground Module

Combine the SEL-2664 with other SEL generator protective devices to continuously monitor field-to-ground resistance and protect critical components, including rotor and stator windings.



### SEL-2600 RTD Module

Measure and transmit data from as many as 12 resistance temperature detector (RTD) inputs and one contact input over a single fiber-optic link.



### SEL-2414 Transformer Automation Controller **NEW**

Control load tap changers and transformer cooling stages with one device. The SEL-2414 offers comprehensive voltage regulation, transformer monitoring, and flexible I/O options to fit your application requirements.

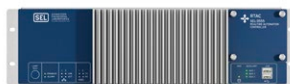

### SEL-3555 Real-Time Automation Controller (RTAC)

The SEL-3555 provides powerful processing for large-scale automation projects.



### SEL-2742 Ethernet Switch

The SEL-2742 is a 12-port, DIN-rail-mount switch for industrial environments. It combines with the SEL-5056 Network Management System (NMS) to simplify network engineering and improve LAN security.

Applications	SEL-400G	SEL-300G	SEL-700G	SEL-700GT	SEL-700GW
Generator Protection	■	■	■	+	■ <sup>1</sup>
Unit/Overall (Generator + Generator Step-Up [GSU]) Differential Protection	■	+	■		
Independent GSU Transformer Protection	■				
Pumped-Storage Hydro Protection	■		■		
Integrated Synchronizer	+		+	+	
Breaker Failure Protection	■	<i>f</i>	■	■	■
Equipment Thermal Monitoring	■	+	+	+	+
Generator Intertie Protection				■	

### Instrumentation and Control

SELogic® Control Equations/Remote Control Switches	■	■	■	■	■
Nonvolatile Latch Control Switches	■	■	■	■	■
Multiple Settings Groups	■	■	■	■	■
Station Battery Monitor	■	■			
Breaker Wear Monitor	■	■	■	■	■
Event Report (Multicycle Data)/Sequential Events Recorder	■	■	■	■	■
Disturbance Recording up to 300 seconds	■				
Demand Meter	■	■	■	■	■
Load Profile Report	■		■	■	■
RTD Inputs	+	+	+	+	+
Ethernet	+		+	+	+
Built-In Web Server	+		+	+	+
EtherNet/IP			+	+	+
IEEE 1588 Precision Time Protocol (PTP)	+		+	+	+
IEC 61850 Edition 2	+		+	+	+
IEC 60870-5-103			+	+	+
Parallel Redundancy Protocol (PRP)	+		+	+	+
DNP3 Serial	■		+	+	+
DNP3 LAN/WAN	+		+	+	+
Simple Network Time Protocol (SNTP)	+		+	+	+
Rapid Spanning Tree Protocol (RSTP)			+	+	+
Modbus TCP	+		+	+	+
Modbus RTU		■	■	■	■
IEEE C37.118 Synchrophasors (With Protocol Edition)	■	2011	■	2005	2005
MIRRORED BITS® Communications	■		■	■	■

### Miscellaneous

Dual Frequency Zones (Generator and System)	■				
Frequency Tracking Range	5–120 Hz	20–70 Hz	15–70 Hz	15–70 Hz	15–70 Hz
Accepts Wye or Open-Delta Voltage Transformers	■	■	■	■	■
Connectorized® (Quick Disconnect) Available	+	+			

Protection	SEL-400G	SEL-300G	SEL-700G	SEL-700GT	SEL-700GW
21C Compensator Distance		■	+		
21P Phase Mho Distance	■	■			
24 Overexcitation (Volts/Hertz)	■	■	■	+	
25 Synchronism Check	■	+	+	+	
27/59 Under-/Overvoltage	■	■	■	+	
27I/59I Inverse-Time Undervoltage/Overvoltage	■		■	■	
32 Directional Power	■	■	■	+	
40 Impedance-Based Loss of Field	■	■	■	+	
40 Capability-Based Loss of Field	■				
46 Current Unbalance	■	■	■	+	
46 Harmonic Current Unbalance	■				
49 Thermal Model	■	■	■	+	
49R Thermal Overload (RTD)	■		■	■	■
50 (P,N,G) Overcurrent (Phase, Neutral, Ground)	■	■	■	■	■
50Q Negative-Sequence Overcurrent	■	+	■	■	■
51 (N,G) Time Overcurrent (Neutral, Ground)	■	■	■	■	■
51 (P,Q) Time Overcurrent (Phase, Neg. Seq.)	■	■		■	■
60 Loss of Potential	■	■	■	+	
60 Voltage Balance Loss of Potential	■				
60 (P,N) Independent Split-Phase (Phase, Neutral)	■				
64G 100 Percent Stator Ground	■	■	+		
64G Intermittent Ground Fault Detection	■				
64F Field Ground	■	■	■	■	■
67 (N,G) Directional Overcurrent (Neutral, Ground)	■		■	+	
67Q Negative-Sequence Directional Overcurrent	■			■	
78 Out of Step	■	■	+		
78 Dual Zone (Generator and System) Out of Step With Pole Slip Counters	■				
78VS Vector Shift			■	■	
81 Over-/Underfrequency	■	■	■	■	
81A Accumulated Frequency	■				
81R Rate-of-Change of Frequency	■		■	■	
87 Stator Differential	■	+	+		
Transformer Differential	■				
REF Restricted Earth Fault	■		■	+	
Inadvertent Energization	■	■	■	+	
Flashover Protection	■	<i>f</i>	<i>f</i>		
Low-Energy Analog (LEA) Current and Voltage Sensors Support			+	+	+

■ Standard feature + Model option *f* May be created using settings

<sup>1</sup>Protects wind collector system apparatus during overcurrent events



# Industrial and Commercial Protection

[selinc.com/solutions/industrial](http://selinc.com/solutions/industrial)

SEL power management, protection, automation, and control solutions are hard at work in heavy industries and commercial-scale facilities around the world. These solutions protect low- and medium-voltage equipment and help improve system performance, availability, and process efficiency.

## Applications

- Asynchronous (induction) and synchronous motor protection
- Variable-frequency drive protection
- Motor bus transfer systems
- Motor control centers
- Arc-flash mitigation
- Power quality and revenue metering
- Power management and control systems (POWERMAX®)
- Microgrid control systems
- Wide-area protection and remedial action schemes



## Customer Story

Mine Discovers Arc-Flash Detection Saves Lives and Equipment  
[selinc.com/highlights/mining-arc-flash](http://selinc.com/highlights/mining-arc-flash)

## Example System Diagram

Combine SEL low- and medium-voltage protective relays with other SEL automation, monitoring, and control products for a comprehensive solution.

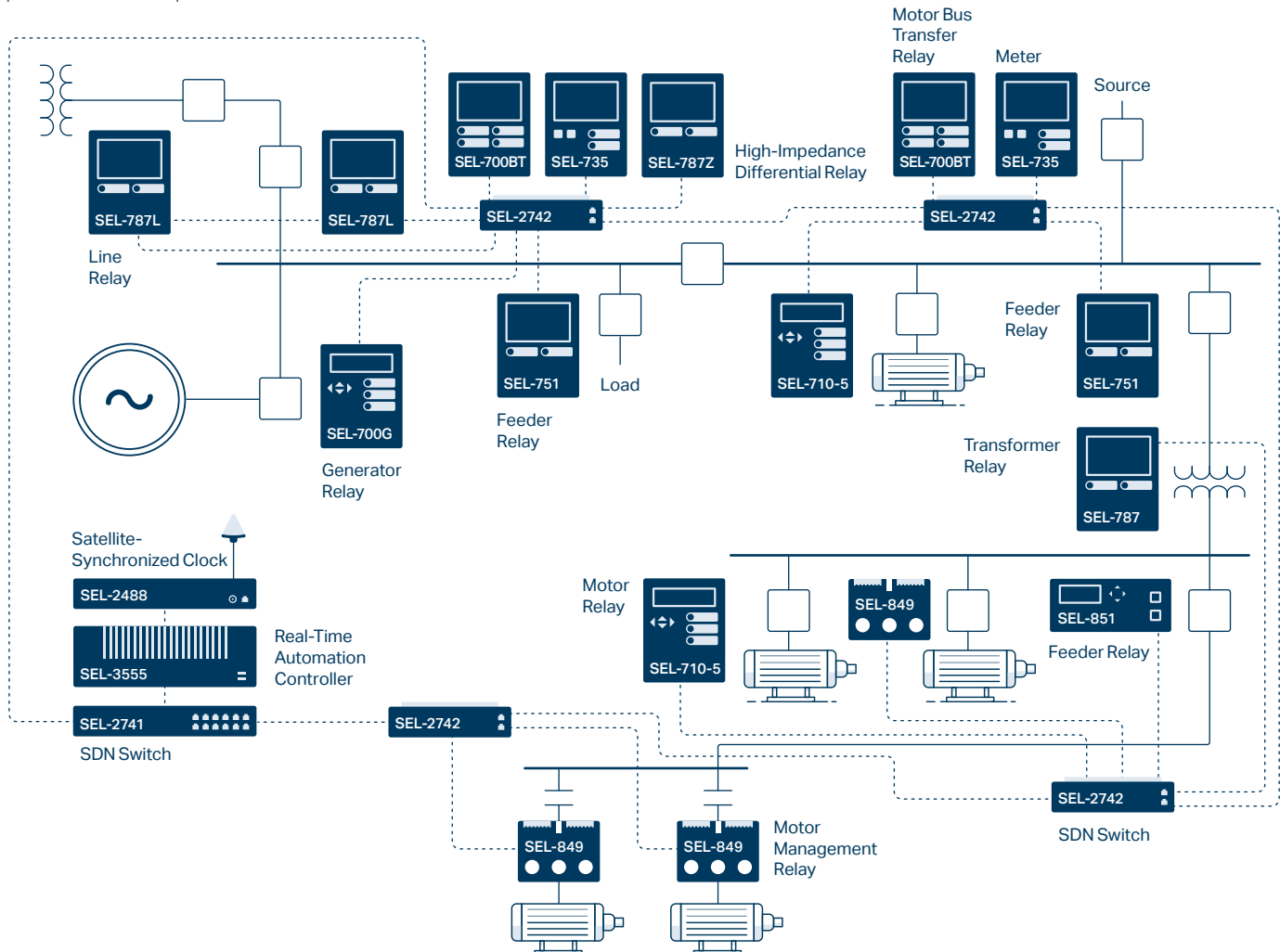

## Webinars

New Cable and Bus Differential Solutions for Data Center Medium-Voltage Power Systems

[selinc.com/events/on-demand-webinar/140097](http://selinc.com/events/on-demand-webinar/140097)

Effective Arc-Flash Mitigation Strategies

[selinc.com/events/on-demand-webinar/139486](http://selinc.com/events/on-demand-webinar/139486)

SEL POWERMAX Power Management and Control System for Industrial Applications (Part 1)

[selinc.com/events/on-demand-webinar/132490](http://selinc.com/events/on-demand-webinar/132490)

## Technical Papers

Case Study: Deployment of 300 Smart Motor Control Centers

[selinc.com/api/download/124143](http://selinc.com/api/download/124143)

Advancement of Safety Features for Industrial Power System Operations and Control

[selinc.com/api/download/140315](http://selinc.com/api/download/140315)

Making My Paper Mill Safer: An Arc-Flash Energy Reduction Story

[selinc.com/api/download/126387](http://selinc.com/api/download/126387)

Case Study: Adaptive Load Shedding in Critical Industrial Facilities

[selinc.com/api/download/130119](http://selinc.com/api/download/130119)

## White Paper

Purpose-Engineered, Active-Defense Cybersecurity for Industrial Control Systems

[selinc.com/api/download/121044](http://selinc.com/api/download/121044)

## Videos

How a Data Center Achieves Utility-Grade Metering

[video.selinc.com/detail/video/5747812817001/how-a-data-center-achieves-utility-grade-metering](http://video.selinc.com/detail/video/5747812817001/how-a-data-center-achieves-utility-grade-metering)

Engineer a Better Network—It Starts With SDN

[video.selinc.com/detail/videos/software-defined-networking](http://video.selinc.com/detail/videos/software-defined-networking)



### SEL-787L Line Current Differential Relay

The SEL-787L is an economical and dependable line current differential protection solution that offers arc-flash protection, fault locating, high-impedance fault detection, and more.



### SEL-751 Feeder Protection Relay

The SEL-751 offers feeder protection, an intuitive color touchscreen, fast and secure arc-flash detection, flexible I/O, and advanced communications.



### SEL-851 Feeder Protection Relay

The SEL-851 is a compact relay that provides overcurrent, voltage, and arc-flash protection as well as versatile communications.



### SEL-700BT Motor Bus Transfer Relay

Ensure motor bus system process continuity by allowing the quick transfer of load to an auxiliary feeder during primary feeder line faults.



### SEL-710-5 Motor Protection Relay

Provide protection, including optional arc-flash detection, for a full range of medium-voltage, three-phase induction, and synchronous motors.



### SEL-849 Motor Management Relay

Provide current-, voltage-, and thermal-based protection; arc-flash detection; and power metering in low-voltage to medium-voltage motor protection applications.



### SEL-700G Generator Protection Relay

Provide standby, emergency, and co-generator protection with an autosynchronizer, flexible I/O, and advanced communications.



### SEL-787-2/-3/-4 Transformer Protection Relay

Apply advanced protection and monitoring with flexible communications to two-, three-, and four-terminal transformers.



### SEL-787Z High-Impedance Differential Relay and SEL-HZM High-Impedance Module

The SEL-787Z combines high-impedance protection principles with advanced numerical technologies to provide high-impedance differential protection. Apply the SEL-787Z and SEL-HZM High-Impedance Module for a comprehensive, single-zone bus-protection solution.



### SEL-735 Power Quality and Revenue Meter

SEL meters offer bidirectional, full four-quadrant, and high-accuracy energy metering as well as precise and reliable power quality measurements.



### SEL-2600 RTD Module

Measure and transmit data from as many as 12 resistance temperature detector (RTD) inputs and one contact input status over a single fiber-optic link.



### SEL-2742 Ethernet Switch

The SEL-2742 is a 12-port, DIN-rail-mount switch for industrial environments. It combines with the SEL-5056 Network Management System (NMS) to simplify network engineering and improve LAN security.

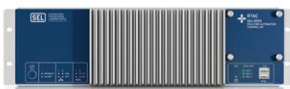

### SEL-3555 Real-Time Automation Controller (RTAC)

The SEL-3555 provides powerful processing for large-scale automation projects.



### SEL-3350 Computing Platform

The SEL-3350 is ideal for limited-space, dedicated embedded applications that require midlevel I/O and computation. It can be configured as a Real-Time Automation Controller (RTAC), as a computer, or with the SEL Blueframe® application platform.

Applications	SEL-787L	SEL-751	SEL-851	SEL-700BT	SEL-710-5	SEL-849	SEL-700G	SEL-787-2/-3/-4	SEL-787Z
Generator Protection		+					■		
Motor Protection					■	■			
Motor Bus Transfer Protection				■					
Feeder Protection	■	■	■	■		■	+		
Transformer Protection								■	
Bus Differential Protection								■	■
Line Current Differential Protection	■								

### Protection

24 Overexcitation (Volts/Hertz)							■	+	
27/59 Under-/Overvoltage	+	+	+	■	■	+	■	+	■
32 Directional Power	+	+	+			+	■	+	
37 Underpower					■	■			
46 Current Unbalance					■	■	■		
47 Phase Reversal					■	■			
49 Thermal	■	■			■	■	■		
49R Thermal Overload (RTD)	+	+		■	+		■	■	
50 Overcurrent	■	■	■	■	■	■	■	+	■
51 Time Overcurrent	■	■	■	■	■	■	■	+	■
55 Power Factor	+	+	+		■	+	<i>f</i>		
60 Loss of Potential	+	+	+	■	■	+	■		
64F Field Ground							■		
67 (N,G) Directional Overcurrent (Neutral, Ground)	+	+	+	■			■		
81 Over-/Underfrequency	+	+	+	■	■	■	■	+	
87 Current Differential					+		+	■	
87L (P,G,Q) Line Differential	■								
87Z High-Impedance Differential									■
REF Restricted Earth Fault							■	+	
Arc-Flash Detection	+	+	+		+	■			+
Separate Neutral Overcurrent	■	■	■	■	■	■	■	+	
Broken Rotor Bar Detection					■				

Instrumentation and Control	SEL-787L	SEL-751	SEL-851	SEL-700BT	SEL-710-5	SEL-849	SEL-700G	SEL-787-2/-3/-4	SEL-787Z
Breaker Wear Monitoring	■	■		■	■		■	■	
RTD Inputs	+	+		+	+		+	+	
Low-Energy Analog (LEA) Current and Voltage Sensors Support	+	+		+	+		+	+	
IEC 61850 Edition 2			+	+	+		+	+	+
IEC 61850 Edition 2.1	+	+							
IEC 61869-9 SV Publishing			+						
Parallel Redundancy Protocol (PRP)	+	+	+	+	+	■	+	+	+
DNP3 Serial	+	+	+	+	+	+	+	+	+
DNP3 LAN/WAN	+	+	+	+	+	+	+	+	+
Simple Network Time Protocol (SNTP)	+	+	■	+	+	■	+	+	+
Built-In Web Server	+	+	■	+	+	■	+	+	+
IEEE 1588 Precision Time Protocol (PTP)	+	+	+	+	+		+	+	+
EtherNet/IP	+	+	+	+	+	+	+	+	+
Modbus TCP	+	+	■	+	+	+	+	+	+
Modbus RTU Outstation	■	■	■	■	■	■	■	■	■
Rapid Spanning Tree Protocol (RSTP)	+	+	+	+	+		+	+	+

■ Standard feature    + Model option    *f* May be created using settings



# Transmission Line Protection and Fault Locating

[selinc.com/products/categories/protective-relays/#line-protection](https://selinc.com/products/categories/protective-relays/#line-protection) | [selinc.com/products/categories/fault-locating](https://selinc.com/products/categories/fault-locating)

SEL transmission line protective relays provide reliable subcycle line current differential and multizone distance protection. Their fault-locating capabilities allow you to efficiently dispatch line crews to quickly isolate line problems and restore service faster.

## Applications

- Time-domain line protection
- Differential protection
- Pilot protection: directional and distance
- Step distance protection
- Single-pole tripping
- Series-compensated lines
- Single- and dual-breaker terminals

## Technical Papers

Modern Line Current Differential Protection Solutions

[selinc.com/api/download/6390](https://selinc.com/api/download/6390)

Transmission Line Protection System for Increasing Power System Requirements

[selinc.com/api/download/2603](https://selinc.com/api/download/2603)

A Fresh Look at Limits to the Sensitivity of Line Protection

[selinc.com/api/download/8505](https://selinc.com/api/download/8505)

Series Compensation, Power Swings, and Inverter-Based Sources and Their Impact on Line Current Differential Protection

[selinc.com/api/download/21474837052](https://selinc.com/api/download/21474837052)

Speed of Line Protection – Can We Break Free of Phasor Limitations?

[selinc.com/api/download/106193](https://selinc.com/api/download/106193)

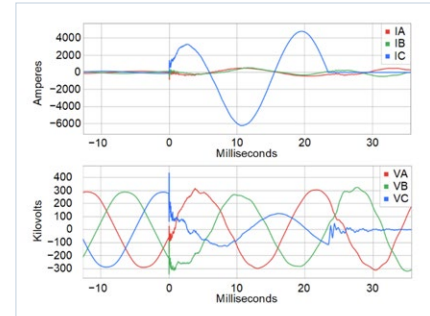

## Real-World Event Reports

Field Experiences With Traveling-Wave Protection and Fault Locating

[selinc.com/mktg/122973](https://selinc.com/mktg/122973)

## Webinar

Detecting and Locating a Broken Conductor Before It Converts Into a Fault

[selinc.com/events/on-demand-webinar/136022](https://selinc.com/events/on-demand-webinar/136022)



### SEL-T401L Ultra-High-Speed Line Relay

Apply the SEL-T401L, which was built on the field experience of the SEL-T400L, for its unprecedented operating speed and complete suite of primary and backup line protection functions. The SEL-T401L can trip within 1 ms, records events with a 1 MHz sampling rate, locates faults to the nearest tower, and uses line monitoring to detect and locate incipient and recurring faults.



### SEL-411L Advanced Line Differential Protection, Automation, and Control System

Apply the SEL-411L for comprehensive line differential protection for up to four terminals; subcycle distance protection; and directional overcurrent protection. Use traveling-wave fault locating to pinpoint faults to the nearest tower span. Broken conductor detection logic can identify line breaks on overhead conductors.



### SEL-421 Protection, Automation, and Control System

Apply the SEL-421 for subcycle distance and directional overcurrent protection.



### SEL-9L Line Relay **COMING SOON**

Use the SEL-9L for comprehensive line protection on single- or dual-breaker subtransmission lines. Universal hardware, modern communications and cybersecurity, and flexible firmware options enable you to tailor the relay to your application.



### SEL-311L Line Current Differential Protection and Automation System

Use the SEL-311L for comprehensive, easy-to-apply line differential and four-zone distance protection.



### SEL-311C Transmission Protection System

Apply the SEL-311C-1 for three-pole distance protection, reclosing, monitoring, and control of breakers on transmission lines. Apply the SEL-311C-2/-3 for single-pole tripping.



### SEL-TWFL Dual Traveling-Wave Fault Locator and 12-Channel MHz Recorder

Use the SEL-TWFL alongside existing line protective relays to locate faults and monitor two line terminals at a substation.



### SEL-T4287 Traveling-Wave Test System

Test traveling-wave fault locators and line protective relays (e.g., the SEL-T401L and SEL-411L) using the SEL-T4287, a simple and compact secondary pulse injection test set.

Applications	SEL-T401L	SEL-411L	SEL-421	SEL-311C	SEL-311L	SEL-9L
Pilot Protection—Directional	■	■	■	■	■	+
Pilot Protection—Directional and Distance	■	■	■	■	■	+
Differential Protection	■	■			■	
Step Distance Protection	■	■	■	■	■	+
Single-Pole Tripping	■	■	■	■	■	+
Series-Compensated Lines	■	+	+			
Dual-Breaker Terminals	■	+	■			+

### Major Protection Functions

21P Phase Distance—Mho	4	5	5	4	4	4
21G Ground Distance—Mho	4	5	5	4	4	4
21P Phase Distance—Quadrilateral	4	5	5			4
21G Ground Distance—Quadrilateral	4	5	5	4	4	4
Subcycle Distance Operation	■	+	+	■		■
Nondirectional Distance Zone	1					1
Step Distance Timers	5	5	5	4	4	5
Incremental-Quantity Distance	■					
32 Directional <sup>1</sup>	■	■	■	■	■	■
TD32 Incremental-Quantity Directional	■					
TW32 Traveling-Wave Directional	■					
POTT	■	■	■	■	■	+
DCB	■	■	■	■	■	+
DCUB	<i>f</i>	■	■	■	■	<i>f</i>
DTT	■	■	■	■	■	+
87L Line Current Differential		■			■	
TW87 Traveling-Wave Line Current Differential	■					
50 Instantaneous Overcurrent <sup>1</sup>	4	4	4	4	4	6
51 Inverse-Time Overcurrent <sup>1</sup>	4	10	10	1	1	5
50 Definite-Time Overcurrent <sup>1</sup>	4	4	4	4	4	6
Switch Onto Fault	■	■	■	■	■	■
Breaker Failure		■	■	■	<i>f</i>	+
59 Overvoltage	■	■	■	■	■	■
27 Undervoltage	■	■	■	■	■	■
81 Frequency		■	■	■	■	■
49 Thermal		■	■			<i>f</i>
Out of Step	■	■	■	■	■	+

Instrumentation and Control	SEL-T401L	SEL-411L	SEL-421	SEL-311C	SEL-311L	SEL-9L
Loss of Potential	■	■	■	■	■	■
Load Encroachment	■	■	■	■	■	■
Power Swing Blocking	■	■	■	■	■	+
Synchronism Check		■	■	■	■	+
79 Automatic Reclosing		■	■	■	■	+
SELogic® Control Equations	■	■	■	■	■	■
Nonvolatile Latch Control Switches	■	■	■	■	■	■
SELogic Remote and Local Control Switches	■	■	■	■	■	■
Programmable Math Operations		■	■			■
Direct Fiber	■	■		■	■	■
SEL MIRRORING BITS®	■	■	■	■	■	■
IEEE C37.94	■	■			■	■

### Fault Locating, Monitoring, and Recording

Fault Locating—Single-Ended Impedance	■	■	■	■	■	■
Fault Locating—Multi-Ended Impedance	■	■				
Fault Locating—Single-Ended Traveling Wave	■					
Fault Locating—Multi-Ended Traveling Wave	■	+				
Broken Conductor Detection		+				
Breaker Wear Monitor		■	■	■	■	
Substation Battery Monitor		■	■	■	■	■
Trip Coil Monitor		<i>f</i>	<i>f</i>	<i>f</i>	<i>f</i>	■
Advanced Trip Circuit Monitoring						■
Event Recorder (DFR)	■	■	■	■	■	■
Sequential Events Recorder (SER)	■	■	■	■	■	■
High-Resolution (1 MHz) Event Recorder	■					
Metering	■	■	■	■	■	■

■ Standard feature    + Model option    *f* May be created using settings

<sup>1</sup>Phase, negative sequence, and zero sequence

SCADA/HMI Integration and Protocols	SEL-T401L	SEL-411L	SEL-421	SEL-311C	SEL-311L	SEL-9L
SEL ASCII, Fast Meter, and Fast SER	■	■	■	■	■	
DNP3 Serial		■	■	■	■	
DNP3 LAN/WAN	■	■	■	■		■
Synchrophasors (IEEE C37.118)		■	■	■	■	
IEC 61850		+	+	+	+	+
Parallel Redundancy Protocol (PRP)		■	■	+		+
IEEE 1588 Precision Time Protocol Version 2 (PTPv2)		+	+			
IEC 61850-9-2 Sampled Values		+	+			
IEC 61869-9 Sampled Values		+	+			
Time-Domain Link (TiDL®)		+	+			
SEL Fast Time-Domain Values (1 MHz Sampling Rate Streaming)	■					

### Miscellaneous

Trip-Rated High-Speed Outputs	■	■	■	■	■	■
Software-Invertible CT Polarities		■	■			■
Built-In Playback Test	■					
Display Points		■	■	■	■	■
Configurable Targets		■	■	■		■
Front USB-C Port						■
Programmable Pushbuttons		12	12	10		10
Programmable Contact Inputs, 24–250 V						■
Programmable 1 A/5 A CTs						■
Printable Labels	■	■	■	■		■
Protection With Delta-Connected Voltages				■		
Color Touchscreen Display						■

■ Standard feature + Model option

### Example System Diagram

Combine SEL transmission protective relays with other SEL automation, monitoring, and control products for a comprehensive solution.

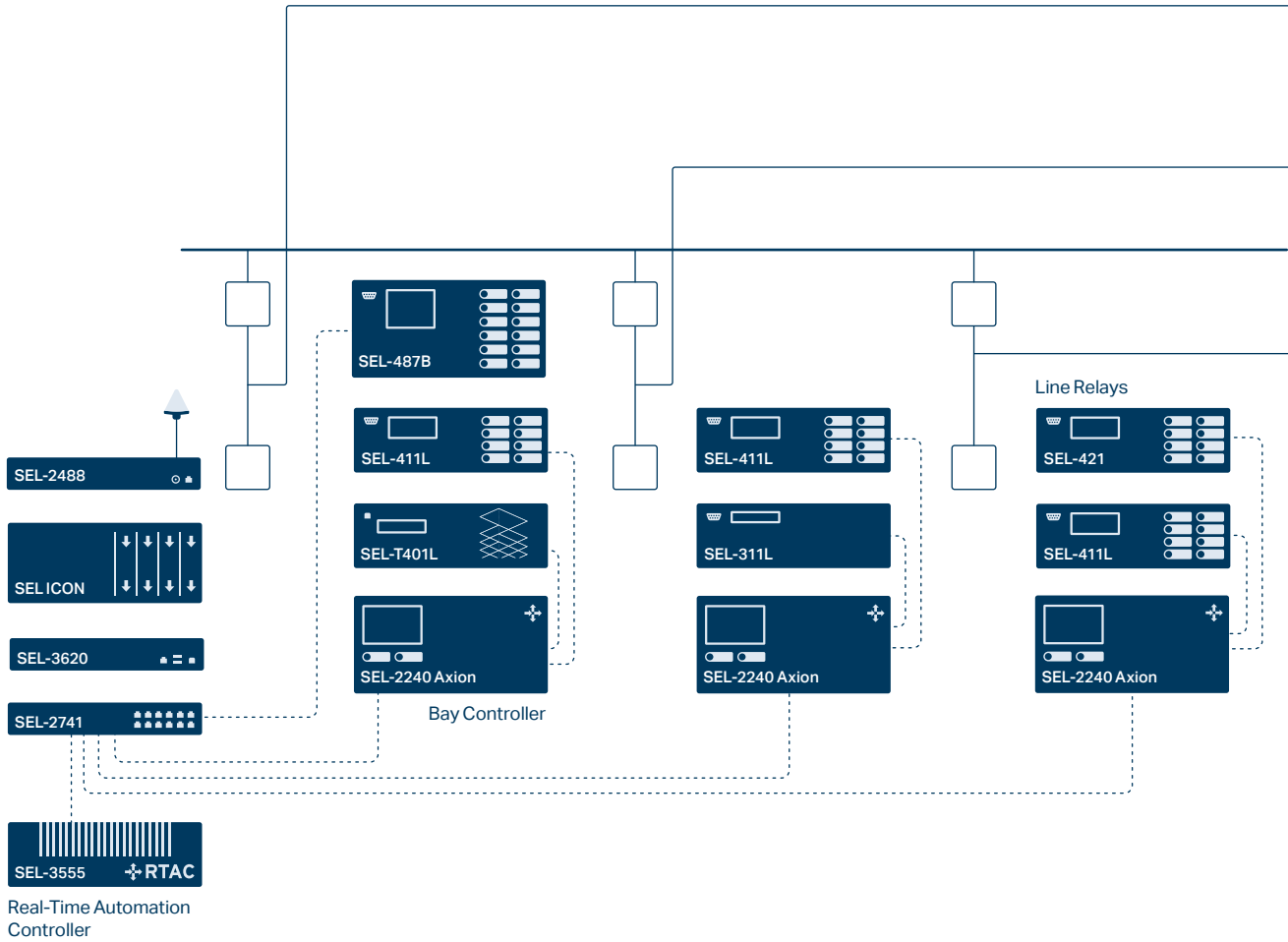

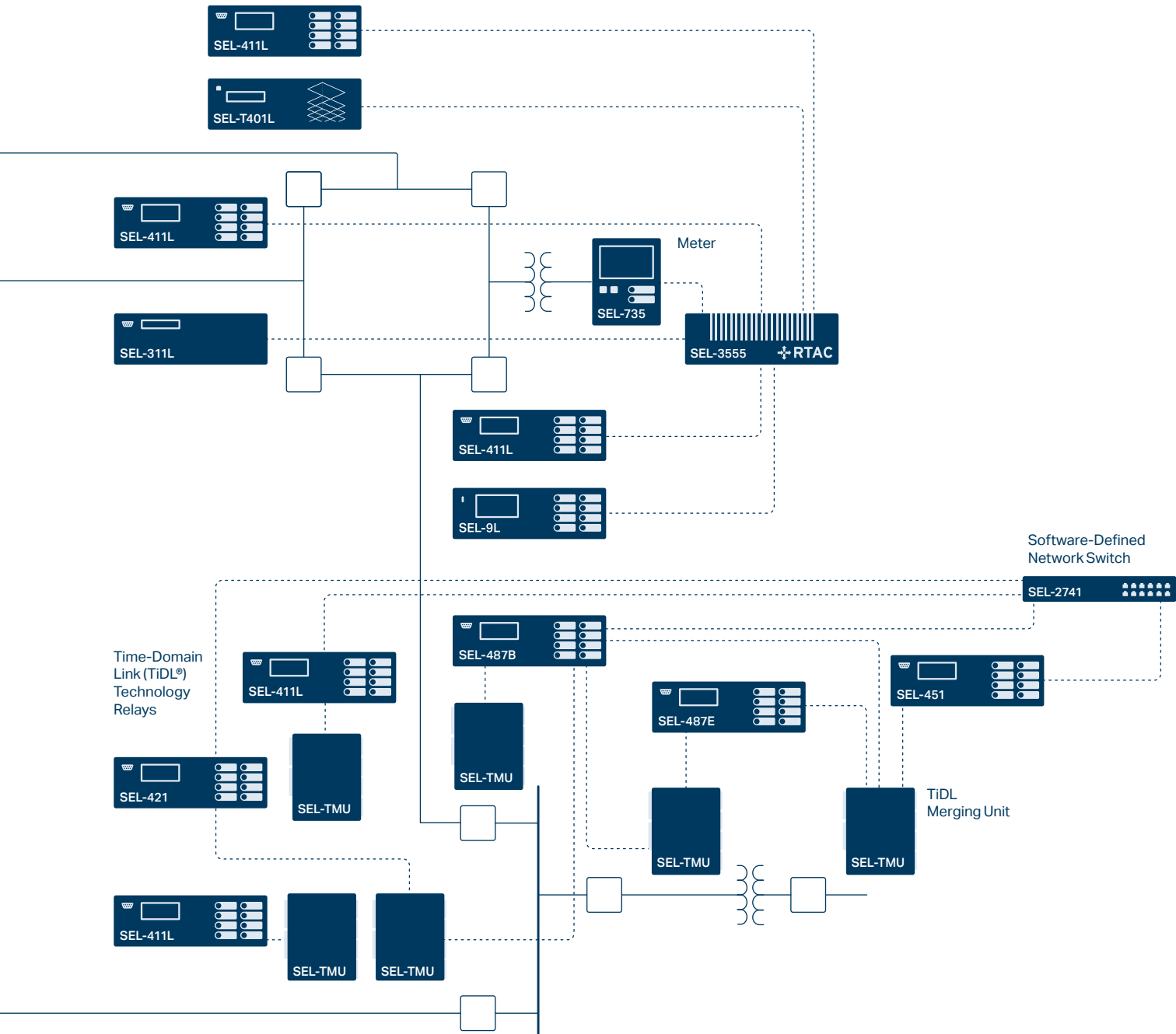



# Substation Protection

[selinc.com/products/categories/protective-relays](https://selinc.com/products/categories/protective-relays)

SEL devices protect, monitor, and control critical assets located in all types of generation, transmission, and distribution substations.

## Applications

- Transformer protection, monitoring, and control
- Bus protection
- Breaker failure protection
- Capacitor bank protection
- Digital secondary systems that use Time-Domain Link (TiDL®) or IEC 61850 technologies

## Webinars

Protect Multiple Substation Assets Using One Relay: CPC Solutions With the SEL-487E

[selinc.com/events/on-demand-webinar/139281](https://selinc.com/events/on-demand-webinar/139281)

Innovation in IEC 61850 Digital Secondary Systems

[selinc.com/events/on-demand-webinar/137779](https://selinc.com/events/on-demand-webinar/137779)

## Technical Papers

Considerations for Using High-Impedance or Low-Impedance Relays for Bus Differential Protection

[selinc.com/api/download/5562](https://selinc.com/api/download/5562)

Beyond the Nameplate—Selecting Transformer Compensation Settings for Secure Differential Protection

[selinc.com/api/download/114458](https://selinc.com/api/download/114458)

Beyond the Nameplate: Transformer Compensation Revisited—New Applications, Greater Simplicity

[selinc.com/api/download/138123](https://selinc.com/api/download/138123)

Performance of IEC 61850 Sampled Values Relays for a Real-World Fault

[selinc.com/api/download/137357](https://selinc.com/api/download/137357)

Redundant Bus Protection Using High-Impedance Differential Relays

[selinc.com/api/download/121745](https://selinc.com/api/download/121745)

Principles of Shunt Capacitor Bank Application and Protection

[selinc.com/api/download/6395](https://selinc.com/api/download/6395)



## Customer Story

Creating a Better Future: Innovative Substation Modernization in the Philippines

[selinc.com/highlights/davao-light](https://selinc.com/highlights/davao-light)

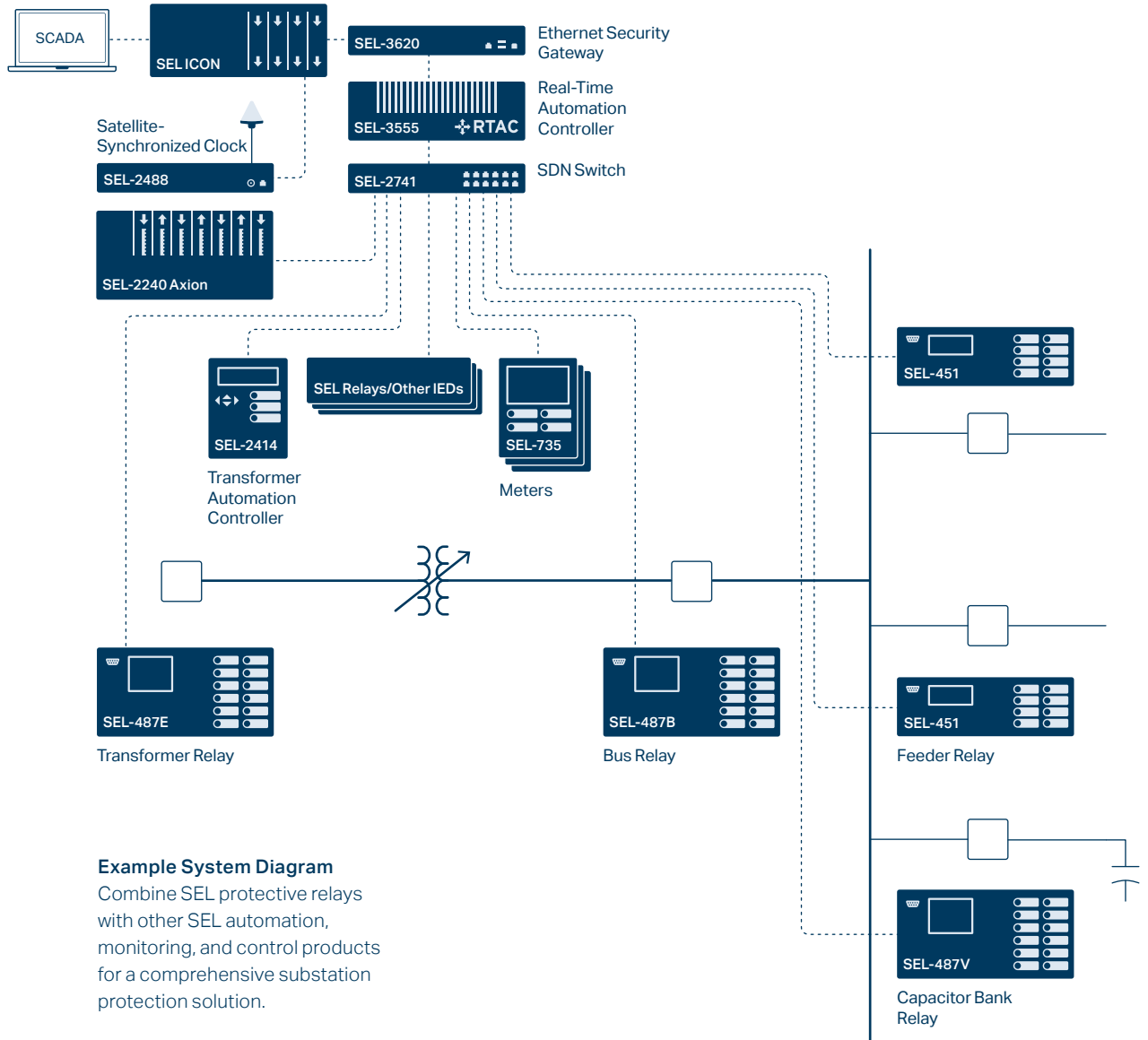

**Example System Diagram**

Combine SEL protective relays with other SEL automation, monitoring, and control products for a comprehensive substation protection solution.



### SEL-352 Breaker Failure Relay

Provide breaker failure protection and breaker control and monitoring with unparalleled flexibility. Point-on-wave opening and closing technology extends breaker life and reduces system transients and restrikes.



### SEL-2414 Transformer Automation Controller **NEW**

Control load tap changers and transformer cooling stages with one device. The SEL-2414 offers comprehensive voltage regulation, transformer monitoring, and flexible I/O options to fit your application requirements.



### SEL-787-2/-3/-4 Transformer Protection Relay

Apply advanced protection and monitoring with flexible communications to two-, three-, and four-terminal transformers.



### SEL-TMU TiDL Merging Unit

Employ the SEL-TMU for remote data acquisition in substations with Time-Domain Link (TiDL) technology systems. It can share data with up to four SEL-400 series TiDL relays.



### SEL-401 Protection, Automation, and Control Merging Unit

Apply merging units in substations with IEC 61850-9-2 Sampled Values (SV) systems. The SEL-401 is a standalone merging unit with phase overcurrent and breaker failure protection. Some SEL SV relays can be configured as merging units to provide local protection that also publishes SV data.



### SEL-787Z High-Impedance Differential Relay and SEL-HZM High-Impedance Module

The SEL-787Z combines high-impedance protection principles with advanced numerical technologies to provide high-impedance differential protection. Apply the SEL-787Z and SEL-HZM High-Impedance Module for a comprehensive, single-zone bus-protection solution.



### SEL-487B Bus Differential and Breaker Failure Relay

Provide bus differential and breaker failure protection, automation, and control in applications with up to seven terminals per relay. Use multiple SEL-487B relays to expand up to 21 protected terminals for scalable protection and control.



### SEL-487E Transformer Protection Relay

Provide high-speed transformer differential protection as well as advanced monitoring, metering, automation, and control. With optional distance, second differential zone, and reclosing functionalities, use the SEL-487E for centralized protection and control applications.



### SEL-487V Capacitor Protection and Control System

Protect and control grounded and ungrounded, single- and double-wye capacitor bank configurations.

## Transformer Protection and Monitoring

Applications	SEL-487E	SEL-387E	SEL-387	SEL-387A	SEL-787-2X/-21/-2E	SEL-787-3E/-3S/-4X	SEL-2414
Breaker Failure Protection	■	<i>f</i>	<i>f</i>	<i>f</i>	■	■	<i>f</i>
Percentage-Restrained Current Differential	■	■	■	■	■	■	
Number of Differential Zones	1 or 2+	1	1	1	1	1	
Underfrequency Load Shedding	■	<i>f</i>			+	+	
Undervoltage Load Shedding	■	<i>f</i>			+	+	
Three-Phase Current Inputs	6	3	4	2	2*	3 or 4	2*
Three-Phase Voltage Inputs	2	1			1*	1*	1*

## Protection

21 Phase and Ground Distance	+						
24 Overexcitation (Volts/Hertz)	■	■			+	+	
25 Synchronism Check	■					+	
27/59 Under-/Overvoltage	■	■			+	+	
32 Directional Power	■				+	+	
46 Current Unbalance	■						
49 Equipment Thermal Monitoring	■		+		■	■	
50FO Flashover Protection	<i>f</i>	<i>f</i>			<i>f</i>	<i>f</i>	
50 (N,G) Overcurrent (Neutral, Ground)	■	■	■	■	■	■	
50P Phase Overcurrent, 50Q Negative-Sequence Overcurrent	■	■	■	■	■	■	
51 (N,G) Time Overcurrent (Neutral, Ground)	■	■	■	■	■	■	
51P Phase Time Overcurrent	■	■	■	■	■	■	
51Q Negative-Sequence Time Overcurrent	■	■	■	■	■	■	
67 (P,G,Q) Directional Overcurrent (Phase, Ground, Negative Sequence)	■						
81 Under-/Overfrequency	■	■			+	+	
81R Rate-of-Change of Frequency	<i>f</i>						
87 Current Differential	■	■	■	■	■	■	
REF Restricted Earth Fault	■	■	■	+	+	■	

## Instrumentation and Control

Instrumentation and Control	SEL-487E	SEL-387E	SEL-387	SEL-387A	SEL-787-2X/-21/-2E	SEL-787-3E/-3S/-4X	SEL-2414
SELogic® Control Equations	■	■	■	■	■	■	■
Voltage Check on Closing	<i>f</i>	<i>f</i>			<i>f</i>	<i>f</i>	
Transformer Cooling Fan Control	<i>f</i>				<i>f</i>	<i>f</i>	■
On-Load Tap Changer Control							+
Nonvolatile Latch Control Switches	■	■	■	■	■	■	■
SELogic Remote Control Switches	■	■	■	■	■	■	■
SELogic Local Control Switches	■	■	■	■	■	■	■
Display Points	■	■	■	■	■	■	■
Multiple Settings Groups	■	■	■	■	■	■	
Substation Battery Monitor	■	■	■	■	+	+	<i>f</i>
Breaker Wear Monitor	■	■	■	■	■	■	
Event Report (Multicycle Data)	■	■	■	■	■	■	■
Sequential Events Recorder	■	■	■	■	■	■	■
Instantaneous and Demand Meter	■	■	■	■	■	■	■
Load and Temperature Profile Report	■				■	■	■
Custom Recorder (Up to an Hour)							■
RTD (Resistance Temperature Detector) Inputs					+	+	+
Built-In Web Server	■	+			+	+	
Software-Invertible Polarities	■						
IEC 60255-Compliant Thermal Model	■						
IEEE C37.118 Synchrophasors	■				■	■	
IEC 61850	+	+			+	+	+
IEC 61850-9-2 Sampled Values Technology	+						
IEC 61869-9 Sampled Values	+						
Simple Network Time Protocol (SNTP)	■				+	+	■
Parallel Redundancy Protocol (PRP)	■				+	+	■
IEEE 1588 Precision Time Protocol Version 2 (PTPv2)	+				+	+	■
EtherNet/IP					+	+	
Time-Domain Link (TiDL) Technology	+						
Through-Fault Monitor	■	■	+	■	■	■	■
Thermal Model/SEL-2600 RTD Module Communications	■		+	■	+	+	■

■ Standard feature + Model option

*f* May be created using relay elements, device word bits, analog quantities, and timers

## Bus Protection

Applications	SEL-487B	SEL-487E	SEL-787Z
Breaker Failure Protection	■	■	■
Bus Differential	■	■	■
Transformer and Machine Current Differential		■	
High-Impedance Bus Differential			■
Low-Impedance Bus Differential	■	■	
Three-Phase Current Inputs	7/10/21 <sup>1</sup>	6	4
Three-Phase Voltage Inputs	1	2	3

### Protection

27/59 Under-/Overvoltage	■	■	■
46 Current Unbalance	<i>f</i>	■	
47 Voltage Unbalance		<i>f</i>	
50 (N,G) Overcurrent (Neutral, Ground)		■	■
50P Phase Overcurrent	■	■	■
50Q Negative-Sequence Overcurrent		■	■
51 (N,G) Time Overcurrent (Neutral, Ground)		■	■
51P Phase Time Overcurrent	■	■	■
51Q Negative-Sequence Time Overcurrent		■	■
87 Current Differential	■	■	
87Z High-Impedance Differential			■
Single-Pole Trip/Close	■		
Three-Phase Differential Bus Zones	2/3/6 <sup>1</sup>	1 or 2+	1
Check Zones	3		

Instrumentation and Control	SEL-487B	SEL-487E	SEL-787Z
79 Automatic Reclosing	<i>f</i>	+	
Dynamic Zone Selection	■	■	
SELogic Control Equations	■	■	■
Nonvolatile Latch Control Switches	■	■	■
SELogic Remote/Local Control Switches	■	■	■
Display Points	■	■	■
Multiple Settings Groups	■	■	■
Substation Battery Monitor	■	■	
Breaker Wear Monitor		■	
Event Report (Multicycle Data)	■	■	■
Sequential Events Recorder	■	■	■
Instantaneous Meter	■	■	■
Demand Meter		■	
Through-Fault Monitor		■	
Software-Invertible Polarities		■	
IEC 60255-Compliant Thermal Model		■	
IEEE C37.118 Synchrophasors		■	
Synchrophasor Real-Time Control		■	
IEC 61850	+	+	+
IEC 61850-9-2 Sampled Values Technology	+	+	
IEC 61869-9 Sampled Values	+	+	
Built-In Web Server	■	■	+
Simple Network Time Protocol (SNTP)	■	■	+
MIRRORED BITS® Communications	■	■	■
Parallel Redundancy Protocol (PRP)	■	■	+
IEEE 1588 Precision Time Protocol Version 2 (PTPv2)	+	+	+
Time-Domain Link (TiDL) Technology	+	+	

### Miscellaneous Features

Connectorized® (Quick Disconnect) Available	+	+	
---	---	---	--

■ Standard feature    + Model option    <sup>1</sup>1/2/3 relay application

*f* May be created using settings

## Breaker Failure and Capacitor Bank Protection

Applications	SEL-352	SEL-451	SEL-487B	SEL-487V
Breaker Failure Protection, Number of Three-Phase Breakers	1	2	7	1
Bus Differential			■	
Shunt Capacitor Bank Protection		<i>f</i>		■
Underfrequency Load Shedding		<i>f</i>		<i>f</i>
Undervoltage Load Shedding	<i>f</i>	<i>f</i>	<i>f</i>	<i>f</i>

### Protection

25 Synchronism Check	■	■		
27/59 Under-/Overvoltage	■	■	■	■
32/37 Power Elements	■	■	<i>f</i>	■
46 Current Unbalance	■	<i>f</i>	<i>f</i>	■
47 Voltage Unbalance		<i>f</i>		<i>f</i>
49 Equipment Thermal Monitoring	+	■		<i>f</i>
50FO Flashover Protection	■	■		■
50 (N,G) Overcurrent (Neutral, Ground)	■	■		■
50P Phase Overcurrent	■	■	■	■
50Q Negative-Sequence Time Overcurrent		■		■
51 (N,G) Time Overcurrent (Neutral, Ground)		■	<i>f</i>	■
51P Phase Time Overcurrent		■	■	■
51Q Negative-Sequence Time Overcurrent		■		■
60 (N,P) Current Unbalance (Neutral, Phase)				■
67 Directional Overcurrent		■		■
81 Under-/Overfrequency		■		■
81R Rate-of-Change of Frequency				■
87 Current Differential			■	
87V Voltage Differential	■	<i>f</i>		■
Single-Pole Trip/Close	■		■	

Instrumentation and Control	SEL-352	SEL-451	SEL-487B	SEL-487V
Open-Pole Detection		■	<i>f</i>	■
Point-on-Wave (POW) Breaker Control	■			
79 Automatic Reclosing	<i>f</i>	■	<i>f</i>	<i>f</i>
SELogic Control Equations	■	■	■	■
Voltage Check on Closing		■		
Nonvolatile Latch Control Switches	■	■	■	■
SELogic Remote/Local Control Switches	■	■	■	■
Display Points	■	■	■	■
Multiple Settings Groups	■	■	■	■
Substation Battery Monitor	+	■	■	■
Breaker Wear Monitor	+	■		■
Voltage Sag, Swell, and Interruption (VSSI) Recording		■		■
Event Report (Multicycle Data)	■	■	■	■
Sequential Events Recorder	■	■	■	■
Instantaneous Meter	■	■	■	■
Demand Meter		■		■
Harmonic Metering				■
Software-Invertible Polarities		■		
IEC 60255-Compliant Thermal Model		■		
IEEE C37.118 Synchrophasors		■		■
IEC 61850		+	+	+
IEC 61850-9-2 Sampled Values Technology		+	+	
IEC 61869-9 Sampled Values		+	+	
Built-In Web Server		■	■	■
Simple Network Time Protocol (SNTP)		■	■	■
Parallel Redundancy Protocol (PRP)		■	■	■
IEEE 1588 Precision Time Protocol Version 2 (PTPv2)		+	+	
Time-Domain Link (TiDL) Technology		+	+	
SEL-2600 RTD Module Communications	+	■		■

### Miscellaneous Features

Connectorized (Quick Disconnect) Available	+	+	+	+
Synchrophasor Real-Time Control		■		■

■ Standard feature + Model option

*f* May be created using relay elements and timers



## Webinars

Wildfire Mitigation—SEL Solutions for Transmission and Distribution Systems  
[selinc.com/events/on-demand-webinar/139282](http://selinc.com/events/on-demand-webinar/139282)

The Next Evolution in FLISR Simplicity: Automatic Configuration With GIS Data  
[selinc.com/events/on-demand-webinar/138534](http://selinc.com/events/on-demand-webinar/138534)

Improving Voltage Regulation in Systems With DERs  
[selinc.com/events/on-demand-webinar/138448](http://selinc.com/events/on-demand-webinar/138448)

SEL Capacitor Bank Controls: More Than Just an On/Off Switch  
[selinc.com/events/on-demand-webinar/139182](http://selinc.com/events/on-demand-webinar/139182)

## Technical Papers

Improving Distribution System Reliability With High-Density Coordination and Automatic System Restoration  
[selinc.com/api/download/137363](http://selinc.com/api/download/137363)

Using Existing Distribution Protection and Control Capabilities for Integration of Distributed Energy Resources  
[selinc.com/api/download/140366](http://selinc.com/api/download/140366)

A New Ground Fault Detection Method in Three-Wire Distribution Systems to Reduce Fire Hazards  
[selinc.com/api/download/140365](http://selinc.com/api/download/140365)

Detecting and Isolating Falling Conductors in Midair—First Field Implementation on Double-Phase Distribution Circuits  
[selinc.com/api/download/blt40d1b00cc2565c3c](http://selinc.com/api/download/blt40d1b00cc2565c3c)

## White Papers

Wildfire Mitigation: Detecting and Isolating Falling Conductors in Midair Using 900 MHz Private LTE at Protection Speeds  
[selinc.com/api/download/135957](http://selinc.com/api/download/135957)

Fire Mitigation for Distribution  
[selinc.com/api/download/126445](http://selinc.com/api/download/126445)

Wireless Current Sensing for Improved Distribution Capacitor Bank Control  
[selinc.com/api/download/130665](http://selinc.com/api/download/130665)

Securing the “Last Foot” in Distribution Automation  
[selinc.com/api/download/136842](http://selinc.com/api/download/136842)

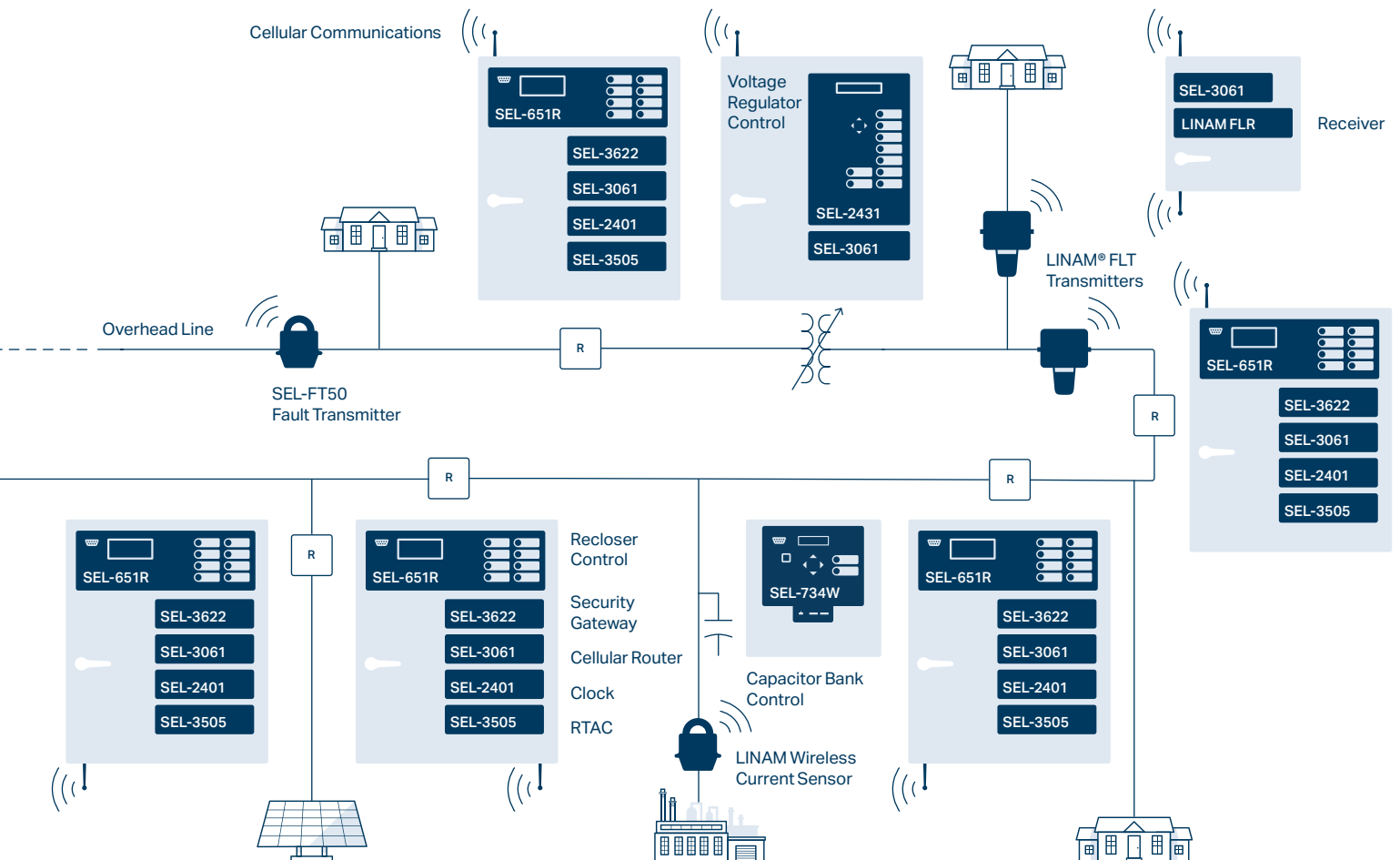



### SEL-851 Feeder Protection Relay

A compact relay for utility and industrial applications that provides overcurrent, voltage, and arc-flash protection as well as versatile communications.



### SEL-751 Feeder Protection Relay

Ideal for industrial and utility feeder protection, offering an intuitive color touchscreen, fast and secure arc-flash detection, flexible I/O, and advanced communications.



### SEL-451 Protection, Automation, and Bay Control System

Flexible overcurrent protection with complete substation bay control.



### SEL-351 Protection System

Transmission or distribution overcurrent protection, monitoring, and control.



### SEL-351A Protection System

An economical solution for distribution feeder protection.



### SEL-351S Protection System

Comprehensive feeder and overcurrent protection perfect for industrial and utility feeder applications.



### SEL Wireless Protection System

- SEL-FT50 Fault Transmitter
- SEL-RP50 Fault Repeater
- SEL-FR12 Fault Receiver

Enhance distribution protection by enabling relays to block reclosing for underground faults, by enabling fast bus tripping, or by coordinating high-density recloser trip blocking.

Applications	SEL-451	SEL-351	SEL-351A	SEL-351S	SEL-851	SEL-751	SEL-751A
Distribution Feeder Protection	■	■	■	■	■	■	■
Breaker Failure (BF) Protection	■	■	f	■	■	■	■
Generator Intertie Protection	■	■	■	■		+	+
Synchronism Check (25)	■	■	■	■		+	+
Underfrequency Load Shedding	f	■	■	■	+	■	■
Undervoltage Load Shedding	f	■	■	■	+	+	+

### Protection

27/59 Under-/Overvoltage	■	■	■	+	+	+	+
32 Directional Power Elements	■	+		+	+	+	+
49 IEC Line/Cable Thermal Overload	■					■	
50 (P,N,G,Q) Overcurrent Element (Phase, Neutral, Ground, Negative Sequence)	■	■	■	■	■	■	■
51 (P,N,G,Q) Time Overcurrent Element (Phase, Neutral, Ground, Negative Sequence)	■	■	■	■	■	■	■
67 (P,N,Q) Directional Overcurrent (Phase, Neutral, Negative Sequence)	■	■	■	■		+	
78VS Vector Shift						+	
81 Over-/Underfrequency	■	■	■	■	+	■	+
Separate Neutral Overcurrent	■	■	■	■	■	■	■
Load Encroachment Supervision	■	■	■	■		+	
Low-Energy Analog (LEA) Voltage Inputs	+					+	
Directional Sensitive Earth Fault Protection		+	+	+		+	
Pilot Protection Logic	■	■		■			
81R Rate-of-Change of Frequency (df/dt)	■	■	■	■		+	+
81RF Fast Rate-of-Change of Frequency	f					+	+
Harmonic Blocking	■	■	+	■	■	■	
Arc Sense™ Technology (AST) High-Impedance Fault Detection	+					+	
Arc-Flash Detection					+	+	+
Phantom Phase Voltage		■	■	■			
Current/Voltage Channels	6/6	4/4	4/4	4/4	4/0 4/3*	4/3 4/5*	4/0 4/5*
Complete Two-Breaker Control	■						

Instrumentation and Control	SEL-451	SEL-351	SEL-351A	SEL-351S	SEL-851	SEL-751	SEL-751A
79 Automatic Reclosing	■	■	■	■	■	+	+
Fault Locating	■	■	■	■		+	
SELogic® Control Equations With Remote Control Switches	■	■	■	■	■	■	■
SELogic Counters	■				■	■	■
Voltage Check on Closing	■	■	■	■		+	+
SELogic Nonvolatile Latch	■	■	■	■	■	■	■
Nonvolatile Local Control Switches	■	■	+	■	■	■	■
Substation Battery Monitor	■	■	■	■		+	+
Breaker/Recloser Wear Monitor	■	■	■	■		■	■
Trip Coil Monitor	f	f	f	f		f	f
Voltage Sag, Swell, and Interruption (VSSI)	■	+		+			
Load/Signal Profile Recorder	■	+		+	■	■	■
Sequential Events Recorder	■	■	■	■	■	■	■
Software-Invertible Polarities	■				■		
IEC 60255-Compliant Thermal Model	■						
DNP3 Level 2 Outstation	■	■	■	■	+	+	+
Parallel Redundancy Protocol (PRP)	+	■	■	■		+	
IEEE 1588 Precision Time Protocol Version 2 (PTPv2)	+					+	
Time-Domain Link (TiDL®) Technology	+						
IEEE C37.118 Synchrophasors	■	■	■	■		■	■
Bay Control	■					+	
Ethernet	+	■	■	■	■	+	+
EtherNet/IP						+	
Built-In Web Server	■				■	■	
IEC 61850	+	+	+	+	+	+	+
IEC 61850 Edition 2	+				+	+	
IEC 61850-9-2 Sampled Values Technology	+						
Firmware Option With MIRRORRED BITS® Communications Available	■	■			■	■	■
Simple Network Time Protocol (SNTP)	■	■	■	■	■	+	+
Harmonic Metering		■	■	■	■		
RMS Metering	■	■	■	■	■	■	■

■ Standard feature + Model option f May be created using settings



### **SEL-651R Advanced Recloser Control**

The SEL-651R provides Automatic Network Reconfiguration and three- and single-phase tripping. It can be used at distributed energy resource (DER) interconnections, for detecting down conductors, and in other distribution automation applications. It is compatible with popular reclosers.



### **SEL-651RA Recloser Control**

The SEL-651RA is a powerful, cost-effective, and flexible recloser control for 14-pin reclosers used in three-phase tripping applications. It can be used at DER interconnections, for detecting down conductors, and in other distribution automation applications. It is compatible with popular reclosers.



### **SEL-351RS Kestrel® Single-Phase Recloser Control**

The SEL-351RS provides integrated logic and communications and comprehensive protection for single-phase applications.



### **SEL-734B Advanced Monitoring and Control System**

The SEL-734B includes low-energy analog inputs and provides advanced monitoring and control capabilities for applications such as capacitor bank control and feeder monitoring.



### **SEL-734W and LINAM® WCS Capacitor Bank Control and Wireless Current Sensor**

This solution is a quick and simple way to provide accurate current, reactive power (VAR), or power factor control for capacitor bank installations and improve power quality.



### **SEL-2431 Voltage Regulator Control**

The SEL-2431 optimizes system voltages and facilitates DER integration by using directional voltage profiles and detailed tap change event reports.

	SEL-351RS Kestrel®	SEL-651R	SEL-651RA
<b>Applications</b>			
Distribution Feeder Protection	■	■	■
Breaker Failure Protection	<i>f</i>	<i>f</i>	<i>f</i>
Generator Intertie Protection		■	■
Recloser Control	■	■	■
Synchronism Check		■	+
Underfrequency Load Shedding	■	■	■
Undervoltage Load Shedding	■	■	■
<b>Protection</b>			
25 (G,T) Generator/Intertie Synchronism Check		■	■
27/59 Under-/Overvoltage	■	■	■
27I Inverse-Time Undervoltage		+	
32 Directional Power Elements	■	■	+
50 (P,N,G,Q) Overcurrent Element (Phase, Neutral, Ground, Negative Sequence)	■	■	■
51 (P,N,G,Q) Time Overcurrent Element (Phase, Neutral, Ground, Negative Sequence)	■	■	■
51V/C Voltage-Restrained/Controlled Time Overcurrent		+	
59I Inverse-Time Overvoltage		+	
67 (P,N,Q) Directional Overcurrent (Phase, Neutral, Negative Sequence)		■	■
78VS Vector Shift		■	■
81 Over-/Underfrequency	■	■	■
81R Rate-of-Change of Frequency (df/dt)	■	■	■
81RF Fast Rate-of-Change of Frequency (ROCOF)		■	■
81W Frequency Window		+	
Separate Neutral Overcurrent		■	■
Load-Encroachment Supervision		■	■
Low-Energy Analog (LEA) Voltage Inputs		+	+
Directional Sensitive Earth Fault Protection		■	■
Pilot Protection Logic		<i>f</i>	<i>f</i>
Harmonic Blocking	■	■	■
Fast Islanding Detection		■	■
Arc Sense Technology (AST) High-Impedance Fault Detection		+	+
Phantom Phase Voltage	■	■	■
Current/Voltage Channels	1/1	4/6	4/1 4/6 <sup>1</sup>

	SEL-351RS Kestrel®	SEL-651R	SEL-651RA
<b>Instrumentation and Control</b>			
79 Automatic Reclosing	■	■	■
Fault Locating	■	■	+
SELogic Control Equations With Remote Control Switches	■	■	■
SELogic Counters	■	■	■
Voltage Check on Closing	■	■	■
SELogic Nonvolatile Latch	■	■	■
Nonvolatile Local Control Switches	■	■	■
Display Points	■	■	■
Breaker/Recloser Wear Monitor	■	■	■
Trip Coil Monitor	<i>f</i>	<i>f</i>	<i>f</i>
IEEE 1547-2018		■	■
Ethernet	■	■	■
IEC 61850	+	+	+
Simple Time Network Protocol (SNTP)	■	■	■

	SEL-351RS Kestrel®	SEL-651R	SEL-651RA	SEL-734B	SEL-734W	SEL-2431
<b>Power Quality</b>						
Voltage Sag, Swell, and Interruption (VSSI)	■	■	■	■	■	<i>f</i>
Load/Signal Profile Recorder	■	■	■	■	■	■
Sequential Events Recorder	■	■	■	■		■
DNP3 Level 2 Outstation	■	■	■	■	■	■
IEEE C37.118 Synchrophasors	■	■	■	■	‡	■
Harmonic Metering	■	■	■	■	■	■
RMS Metering	■	■	■	■	■	■

■ Standard feature + Model option *f* May be created using settings

‡ Except phase currents



# Fault Indicators, Sensors, and CTs

[selinc.com/products/categories/fault-locating/#fault-indicators](http://selinc.com/products/categories/fault-locating/#fault-indicators) | [selinc.com/products/categories/measurement-streaming](http://selinc.com/products/categories/measurement-streaming)

SEL fault indicators and sensors improve reliability by indicating the fault path to speed up the fault-locating time and reduce the outage duration. Suitable for overhead and underground installations, SEL fault indicators and sensors work in a wide range of applications—from overcurrent fault detection to enhancing system protection.

## Applications

- Traditional fault locating for line crews
- Wireless fault locating
- Distribution protection and control enhancement

## Videos

How to Install the AR360 AutoRANGER® Fault Indicator

[video.selinc.com/detail/videos/fault-indicators/video/2925549374001](http://video.selinc.com/detail/videos/fault-indicators/video/2925549374001)

Wireless Protection Communications—Innovating to Improve Reliability

[selinc.com/highlights/aes-ohio](http://selinc.com/highlights/aes-ohio)

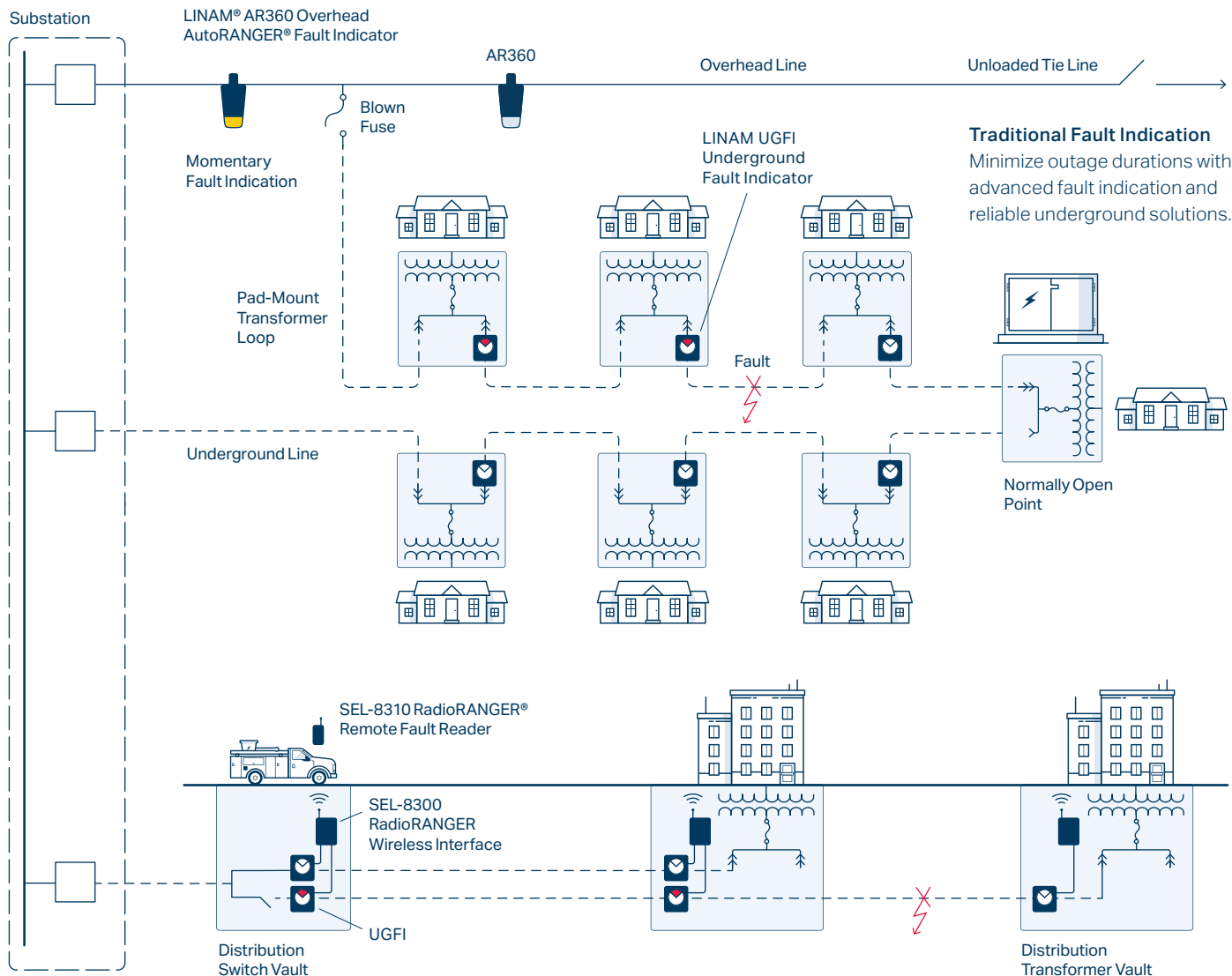

**Traditional Fault Indication**  
Minimize outage durations with advanced fault indication and reliable underground solutions.

## White Papers

Wireless Current Sensing for Improved Distribution Capacitor Bank Control

[selinc.com/api/download/130665](http://selinc.com/api/download/130665)

Fire Mitigation for Distribution

[selinc.com/api/download/126445](http://selinc.com/api/download/126445)

## Wireless Fault Indication

Advanced fault detection solutions optimize distribution reliability.

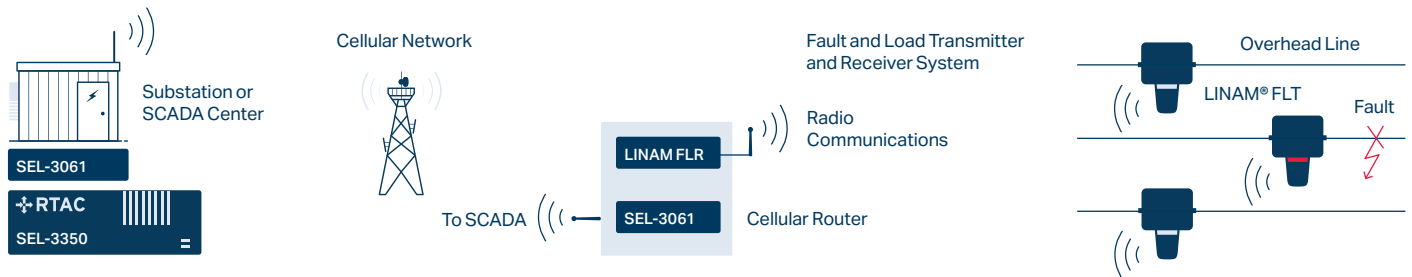

## Substation

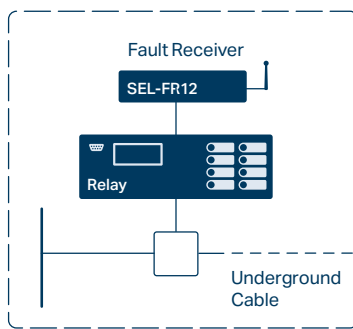

## Protection-Speed Fault Transmitters

Wireless fault transmitters enable reclose blocking for underground faults; high-density recloser trip blocking; and fast bus tripping.

SEL-FT50 Fault Transmitter

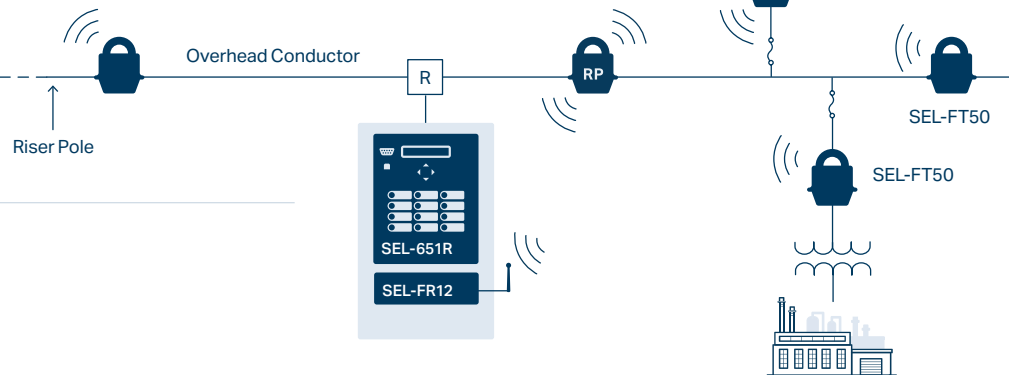

## Loss-of-Voltage Detection

Economical voltage-monitoring solution for source transfer schemes.

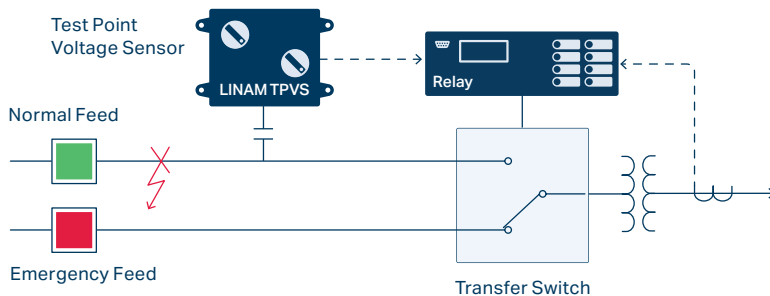

## Technical Papers

Emerging Communications and Sensor Technologies That Advance Distribution Automation

[selinc.com/api/download/124511](http://selinc.com/api/download/124511)

Fast Wind Farm Restoration Using Wireless Fault Sensors to Identify Faulted Segments

[selinc.com/api/download/130379](http://selinc.com/api/download/130379)

## Webinars

Introducing the LINAM® UGFI Underground Fault Indicator

[selinc.com/events/on-demand-webinar/140106](http://selinc.com/events/on-demand-webinar/140106)

A Better Test Point Voltage Sensor for Switchgear

[selinc.com/events/on-demand-webinar/135858](http://selinc.com/events/on-demand-webinar/135858)

Enhance Distribution Protection With the SEL Wireless Protection System

[selinc.com/events/webinar/133828](http://selinc.com/events/webinar/133828)

## Overhead



### LINAM FLT and LINAM FLR Fault and Load Transmitter and Receiver System

Improve overall distribution system reliability with the FLT and FLR system, which indicates faults and monitors load. Speed up deployment in pole-mount applications with the system's enclosure.



### LINAM AR360 and LINAM AR Overhead AutoRANGER Fault Indicators

Locate momentary and permanent faults in overhead applications. The AR360 and AR automatically adjust their trip thresholds to coordinate with the load current in distribution systems.



### LINAM ER Overhead Electrostatic Reset Fault Indicator

Provide maintenance-free fault indication with a battery-free design and automatic voltage reset.



### SEL Wireless Protection System

Enhance distribution protection by enabling relays to block reclosing for underground faults, by enabling fast bus tripping, or by coordinating high-density recloser trip blocking.



### LINAM CRD Overhead Current Reset Fault Indicator

Reduce fault detection time with the CRD, featuring load-current-powered functionality, a 1 ms response time, and single-hot-stick installation.



### LINAM MR Manual Reset Fault Indicator

Troubleshoot overhead and underground applications up to 38 kV with this portable, fault-powered manual reset fault indicator.

## Underground



### LINAM UGFI Underground Fault Indicator **NEW**

Reduce outage durations and improve reliability with the LINAM UGFI, featuring line-powered functionality, adjacent phase immunity, and performance that exceeds IEEE 495 standards.



### RadioRANGER® Underground Wireless Fault Indication System

Reduce the need to access vaults or open pad-mounted enclosures to retrieve the fault indicator status. Decrease fault-locating time and improve safety.



### LINAM TPR Underground Test Point Reset Fault Indicator

Easily install the TPR on most brands of 200 A or 600 A elbows with capacitive test points. It is ideal for pad-mounted transformer and switchgear applications.



### LINAM TPVS Test Point Voltage Sensor

Detect system voltage loss on distribution elbows with capacitive test points. The TPVS is part of an economical solution for source transfer schemes.

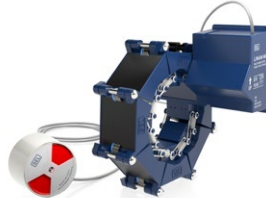

### LINAM MC Multiconductor Cable Fault Indicator

Apply the MC on paper-insulated lead-covered cables. It features a rugged design and can be submerged in up to 15 feet of water.



### LINAM CT Split-Core Current Transformers

Economically add CTs to existing wiring and electrical equipment without interrupting service.



# Metering and Power Monitoring

[selinc.com/solutions/metering-solutions](http://selinc.com/solutions/metering-solutions) | [selinc.com/services/protection-control/metering-demand-management](http://selinc.com/services/protection-control/metering-demand-management)

SEL metering products help operators identify power quality issues and improve energy usage in generation, interchange, transmission, distribution, industrial, and commercial applications.

## Applications

- Power quality monitoring and troubleshooting
- Usage reporting and billing management system integration
- Load profiling and monitoring
- Continuous waveform streaming and recording

## White Paper

Achieve Accurate Metering in Modern Nonsinusoidal Power System Conditions  
[selinc.com/api/download/123140](http://selinc.com/api/download/123140)

## Webinars

Improve Your Power System Visibility  
[selinc.com/events/on-demand-webinar/140676](http://selinc.com/events/on-demand-webinar/140676)

Never Miss an Event: Introducing the SEL-T35 Time-Domain Power Monitor  
[selinc.com/events/on-demand-webinar/139220](http://selinc.com/events/on-demand-webinar/139220)

Solutions for Optimizing Energy Metering and Demand Management  
[selinc.com/events/on-demand-webinar/134511](http://selinc.com/events/on-demand-webinar/134511)



## Customer Stories

SEL Meter Helps Data Center Supply High-Quality, Uninterrupted Power  
[selinc.com/solutions/success-stories/Vantage-Data](http://selinc.com/solutions/success-stories/Vantage-Data)

Minimize the Cost of Harmonic Mitigation With Continuous Waveform Recording  
[selinc.com/CWStestimonial](http://selinc.com/CWStestimonial)

## Example System Diagram

Combine the SEL-735 Power Quality and Revenue Meter with other SEL devices and software for a comprehensive metering data management solution.

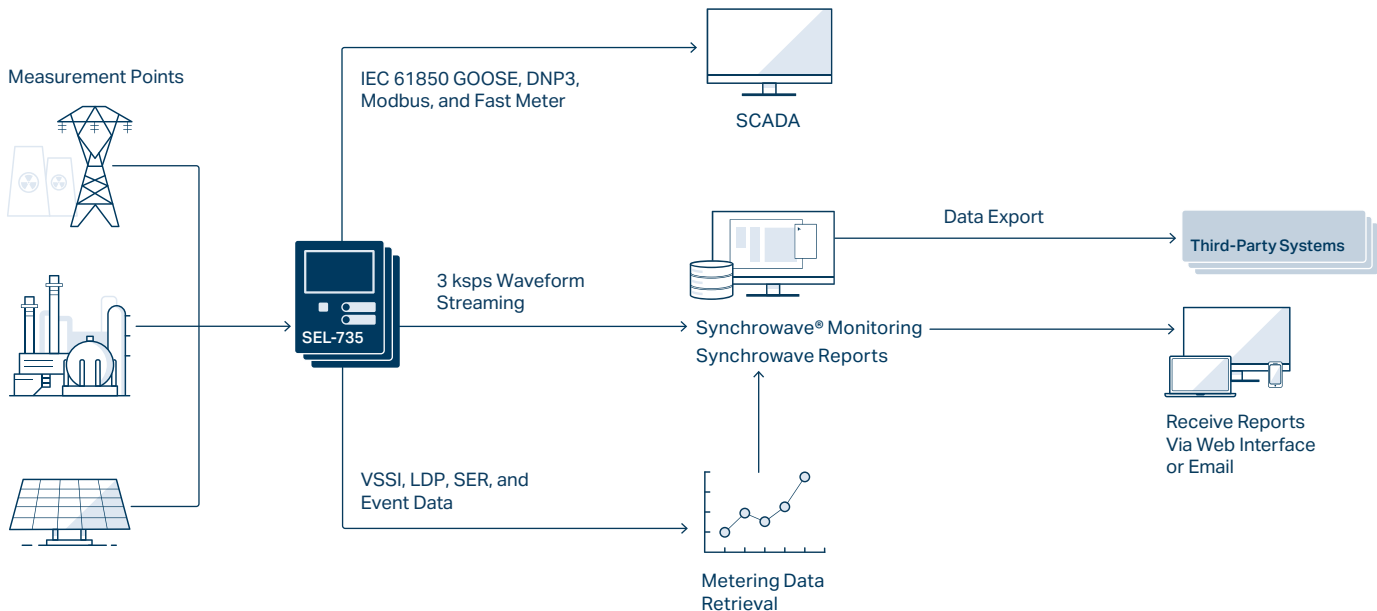



### SEL-735 Power Quality and Revenue Meter

SEL meters offer bidirectional, full four-quadrant, and high-accuracy energy metering as well as precise and reliable power quality measurements.

Capture every disturbance in your system with optional continuous waveform streaming at 3 kps to SEL Synchronwave® software. Multiple mounting and enclosure options and accessories are available; visit [selinc.com/products/735](http://selinc.com/products/735).

### SEL Synchronwave Software

Automate data retrieval, quickly visualize data, and create custom reports with the enterprise data collection and reporting software bundle. Bundling software simplifies ordering and license management, eliminates base license fees, and allows incremental license purchases. View software bundling options below.

### Software Bundling Options

#### ACSELERATOR TEAM® SEL-5045 Software<sup>1</sup>

	Meter Data Option	Power Quality Option	Energy and Power Monitoring Option
Event and SER collection	■	■	■
LDP and VSSI collection	■	■	■

#### SEL-5705 Synchronwave Reports

	Meter Data Reports	Power Quality Reports	Power Quality Reports
Device Overview	■	■	■
SER	■	■	■
LDP	■	■	■
VSSI	■	■	■
Signals or WAGES	■	■	■
IEEE 519 Compliance Report		■	■

#### SEL-5703 Synchronwave Monitoring

	Trending and Archiving Package	Power Monitoring Package
Phasor Measurement Unit (PMU)	■	■
Continuous Waveform Receiving	■	■
Time-Series Historian	■	■
Calculations	■	■
Software PMU	■	■
Virtual Metering	■	■
Visualization	■	■
Data Export	■	■
Notifications/Alarms		■
Oscillation Detection		■
Disturbance Detection		■
PT Failure Detection		■
Threshold Monitoring		■

<sup>1</sup>Both Meter Data and Power Quality options are available without a TEAM license if an application already has TEAM software available.

## Virtual Metering Expands Power Monitoring Capabilities

The Virtual Metering applications in SEL Synchronwave software allows users to generate signals similar to metering analogs using time-stamped signal data as a source. The software automatically converts instantaneous waveforms sampled at 3 or 14.4 ksps into phasor-based quantities. The application calculates current, voltage, power, frequency, harmonics, symmetrical components, and power quality measurements, providing valuable reporting and monitoring data.

## Power Management

SEL Synchronwave software supports event detection and expedites root-cause analysis using streaming data from the SEL-735 meter and SEL-T35 power monitor.

## Related Material

Capture every disturbance with continuous waveform recording. [selinc.com/api/download/138703](http://selinc.com/api/download/138703)

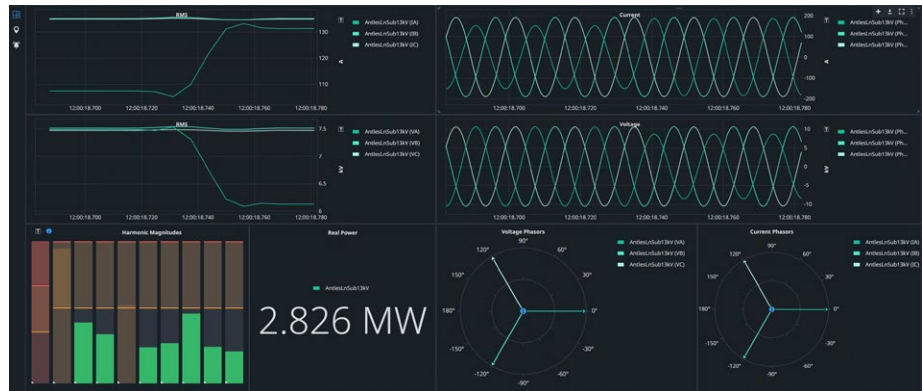

## Metering and Power Monitoring Applications

Application	SEL-735			SEL-T35
	Basic	Intermediate	Advanced	All Models
Revenue Metering	Class 0.1	Class 0.1	Class 0.1	–
SCADA Metering	Yes	Yes	Yes	–
Onboard Storage	128 MB	256 MB	1 GB	–
Event Detection	Basic	Advanced	Advanced	Advanced, virtual metering
Waveform Recording	16 samples/cycle	128 samples/cycle	512 samples/cycle	Virtual metering, 14.4 ksps
SELogic® Control Equations	Yes	Yes	Yes	–
Harmonic Order	15th	63rd	63rd	Virtual metering, 100th
PQ Monitoring	–	Yes	Yes	Virtual metering
Subsynchronous Oscillation Detection	Option with Synchronwave Reports	Option with Synchronwave Reports	Option with Synchronwave Reports	Included
IEEE 519 Compliance Monitoring	–	–	Option with Synchronwave Reports	Included
Synchronwave Software License	Optional	Optional	Optional	Included



### SEL-T35 Time-Domain Power Monitor **NEW**

The SEL-T35 streams high-precision ac and dc voltage and current measurements at 14.4 kilosamples per second (ksps) to the included Synchrowave software for wide-area, real-time data analysis.

Energy packets calculated every millisecond provide energy measurements independent of frequency. An integrated ride-through pack ensures that you never miss a disturbance during short-duration outages.

### SEL Synchrowave Software

Calculate and monitor power quality values in real time using high-rate streaming data.

The Virtual Metering application in Synchrowave software enables system-wide power quality calculations, including harmonics, subsynchronous oscillations, rapid voltage changes, and flicker. Synchrowave can use the calculated harmonic values in IEEE 519 compliance reports.

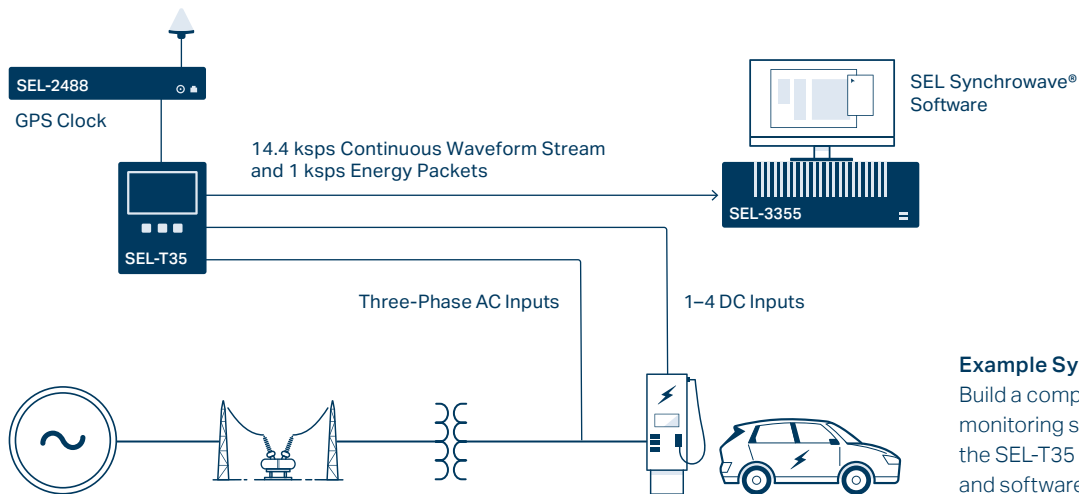

### Example System Diagram

Build a comprehensive power data monitoring solution by combining the SEL-T35 with other SEL devices and software.



# Automation and Computing Platforms

[selinc.com/products/categories/automation-computing](http://selinc.com/products/categories/automation-computing)

Increase system reliability and operation efficiency using SEL automation and computing platforms, which offer scalable and modular solutions for the most demanding utility and industrial applications. SEL automation solutions allow you to implement a broad set of functionalities or choose a subset and add more capabilities over time.

## Applications

- Remote terminal unit (RTU)
- Digital fault recording systems
- Network device auditing
- Power management and control systems (POWERMAX®)
- Distributed energy resource (DER) management (SEL Real-Time Automation Controller [RTAC] Grid Connect)
- Automatic fault location, isolation, and service restoration
- Bay control
- Phasor measurement unit
- Continuous waveform recording and streaming
- Embedded computing systems



## Customer Stories

Pend Oreille Utility Benefits From Innovative RTU Upgrade Strategy  
[selinc.com/highlights/pud](http://selinc.com/highlights/pud)

A System of Robust Reliability for the Water and Wastewater Industry  
[selinc.com/solutions/success-stories/brunswick](http://selinc.com/solutions/success-stories/brunswick)

## Automation News

[selinc.com/products/automation/news](http://selinc.com/products/automation/news)

## Example System Diagram

Combine SEL automation and computing platforms with SEL protective relays and software for a comprehensive solution.

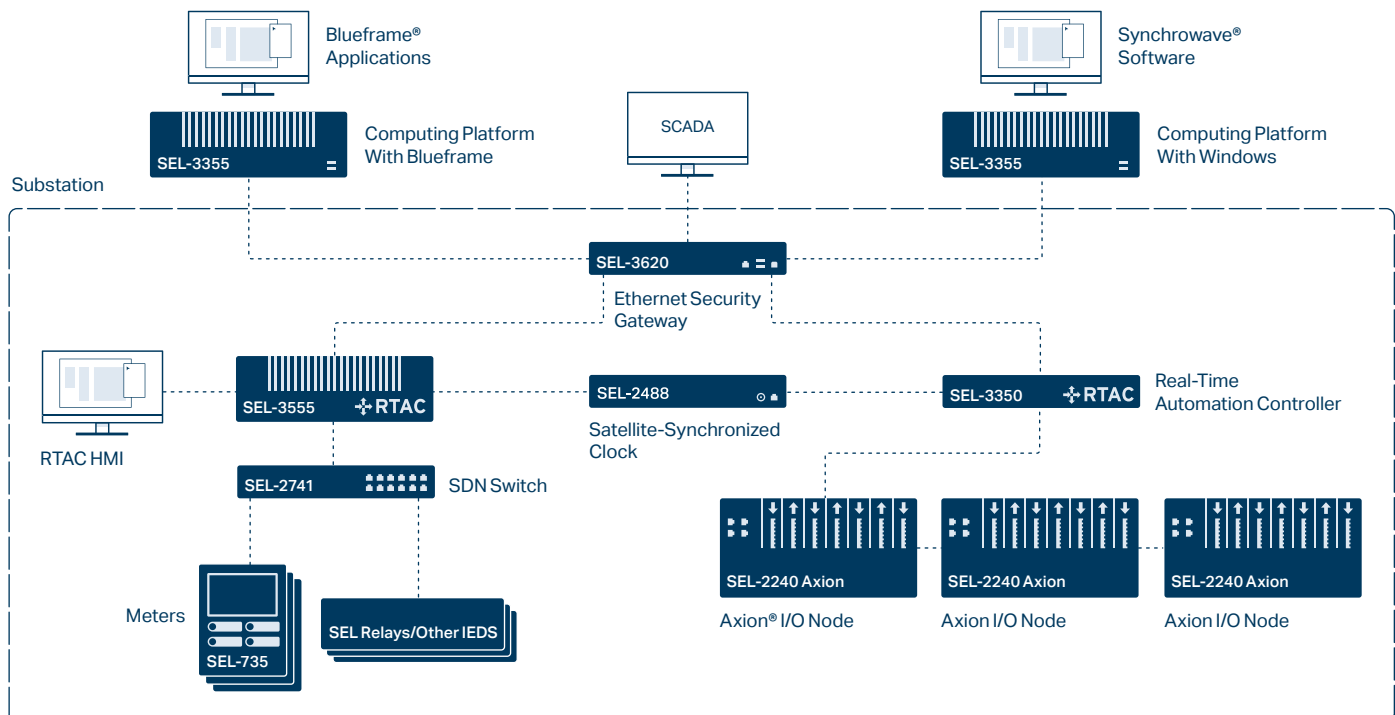

## Webinars

Innovating DFR Solutions—Continuous Oscillography, Asset Monitoring, and More  
[selinc.com/events/webinar/138498](http://selinc.com/events/webinar/138498)

RTAC and Axion® Advancements for RTU and Substation Gateway Applications  
[selinc.com/events/on-demand-webinar/137925](http://selinc.com/events/on-demand-webinar/137925)

Managing DERs With RTAC Grid Connect  
[selinc.com/events/on-demand-webinar/138107](http://selinc.com/events/on-demand-webinar/138107)

Software-Based Password Rotation With DMA Credential Management  
[selinc.com/events/on-demand-webinar/137643](http://selinc.com/events/on-demand-webinar/137643)

## Technical Papers

Simplifying Compliance: An Integrated Approach to Meeting NERC PRC-002 and PRC-005 Requirements  
[selinc.com/api/download/130034](http://selinc.com/api/download/130034)

New Advancements in Solar Grid Controllers  
[selinc.com/api/download/130047](http://selinc.com/api/download/130047)

Wind Farm Volt/VAR Control Using a Real-Time Automation Controller  
[selinc.com/api/download/99167](http://selinc.com/api/download/99167)

## White Paper

Using Defense in Depth to Safely Present SCADA Data for Read-Only and Corporate Reporting  
[selinc.com/api/download/120437](http://selinc.com/api/download/120437)

## Related Materials

SEL Advanced Digital Fault Recorder (DFR) Solutions  
[selinc.com/api/download/122510](http://selinc.com/api/download/122510)

POWERMAX Solutions  
[selinc.com/api/download/106293](http://selinc.com/api/download/106293)

Capture Every Disturbance With Continuous Waveform Recording  
[selinc.com/api/download/138703](http://selinc.com/api/download/138703)



### SEL-3350 Computing Platform

The SEL-3350 is a cost-effective model ideal for applications that require midlevel I/O and computation. It can be deployed as an RTAC, an industrial computer running a Microsoft Windows or Linux OS, or a Blueframe® application platform.



### SEL-3355 Computing Platform

The SEL-3355 is a server-class computing platform built to withstand harsh environments in utility substations and industrial control and automation systems. It can be deployed as an industrial computer running a Microsoft Windows or Linux OS or as a Blueframe application platform.



### SEL-3360S/3360E Compact Computing Platform

These models match the performance, ruggedness, and configuration flexibility of the SEL-3355 and are ideal for surface- or panel-mount applications. They can be deployed as industrial computers running a Microsoft Windows or Linux OS or as Blueframe application platforms.



### SEL-3505/3505-3 RTAC

These RTACs offer powerful automation, reporting, and control for low-voltage, limited-space applications.

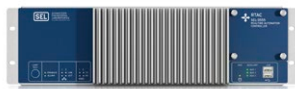

### SEL-3555 RTAC

The SEL-3555 provides powerful processing for large-scale automation projects.



### SEL-3560E/3560S RTAC

These RTACs offer powerful processing for large-scale automation projects in a compact form factor.



## SEL-2240 Axion®

The Axion is a ruggedized, high I/O count, modular platform that supports multiple utility and industrial applications on a single device. Common applications include bay control, SCADA data concentration, digital fault recording, microgrid monitoring and control, power quality monitoring, and deployment as an RTU.

## RTAC Automation Software

### ACSELERATOR RTAC® SEL-5033 Software

Included with an SEL RTAC purchase, ACSELERATOR RTAC is an intuitive, easy-to-use application designed to configure the SEL RTAC family of products, including the Axion.

### RTAC HMI Builder

Included with an SEL RTAC purchase, ACSELERATOR Diagram Builder™ SEL-5035 Software enables the creation and management of HMI visualization projects for the RTACs in your system.

### ACSELERATOR® Bay Screen Builder SEL-5036 Software

Included with ACSELERATOR QuickSet® SEL-5030 Software and ACSELERATOR RTAC, Bay Screen Builder works with QuickSet and ACSELERATOR RTAC to enable the custom creation of bay screens for SEL devices with touchscreen displays.

### RTAC Extensions

Simplify automation programming with RTAC extensions. These preconfigured logic suites support automation solutions such as digital fault recording, DER monitoring, and IEC 61850 device monitoring.

## SEL Blueframe

### SEL Blueframe Application Platform

Scalable and flexible, SEL Blueframe provides a secure operational technology (OT) platform for installing applications and for managing and exchanging data between supported applications.

### Distribution Management System (DMS) Application Suite

The DMS suite includes the Fault Location, Isolation, and Service Restoration (FLISR) application package, which reduces customer outages, improves reliability metrics, and provides rapid fault detection and system restoration.

### Device Management and Automation (DMA) Application Suite

DMA applications automatically collect, store, and manage device-specific information to simplify day-to-day management of a system of devices and to support compliance.



## SEL-2411 Programmable Automation Controller

The SEL-2411 provides flexible I/O for automatic control, SCADA, station integration, remote monitoring, and plant control systems.



## SEL-2411P Pump Automation Controller

The SEL-2411P is a standalone, SCADA-ready system for control and monitoring of water and wastewater pump applications.



## SEL-2414 Transformer Automation Controller **NEW**

Control load tap changers (LTCs) and transformer cooling stages with one device. The SEL-2414 offers comprehensive voltage regulation, transformer monitoring, and flexible I/O options to fit your application requirements.



## SEL-2440 Discrete Programmable Automation Controller (DPAC)

The SEL-2440 offers utility-grade I/O, powerful processing, flexible communications, and microsecond timing.

Applications	SEL-3355	SEL-3360E	SEL-3360S	SEL-3350	SEL-3555	SEL-3560E	SEL-3560S	SEL-3530-4	SEL-2240	SEL-3505/3505-3	SEL-3533	SEL-2411	SEL-2411P	SEL-2414	SEL-2440
Collect, Scale Meter Data	+/#	+/#	+/#	+/#	■	■	■	■	■	■	■	■	■	■	■
Condition Monitoring	■	■	■	■	■	■	■	■	■	■	■			■	
Transformer Load Tap Changer Control														+	
IED Report/Event Collection	+	+	+	■	■	■	■	■	■	■	■				
Digital Fault Recording				+	■	■	■		■						
Collect Targets, Contact Input Status, Fault Location	■	■	■	+	■	■	■	■	■	■	■				
Enable Fiber-Optic Links	+	+		+	+	+		■	■	■	■	■	■	■	■
Control Through IED Outputs				■	■	■	■	■	■	■	■	■	■	■	■
IRIG-B Client Time Synchronization	■	■	■	■	■	■	■	■	■	■	+	■	■	■	■
IRIG-B Server Time Distribution	+	+		■	■	■	■	■	■	■	+				
IRIG-B Time Distribution and Network Time Protocol (NTP) Conversion	+	+		■	■	■	■	■	■	■	+				
Transparent "Port Switch"	■	■	■	+	■	■	■	■	■	■	■	■	■	■	■
Windows/Linux Applications in Harsh Environments	+/#	+/#	+/#	+/#											
Running Multiple Applications Simultaneously	■	■	■	■											
Installing Third-Party Software	+	+	+	+											
Security Appliance to Help Satisfy NERC CIP Requirements	■	■	■	+/#	■	■	■	■	■	■	■				
Network Monitoring and Intrusion Detection	■	■	■	■	+										
Virtualization Server	+/#	+/#	+/#												
Engineering Access Point	+/#	+/#	+/#	+/#	■	■	■	■	■	■	■				
Video Surveillance Control and Archiving/Physical Security Monitoring and Notification	■	■	■	■											
Concentrate Data for Distributed Control System (DCS)				+	■	■	■	■	■	■	■				
Concentrate Data for SCADA Master or Remote Terminal Unit (RTU)	■	■	■	+	■	■	■	■	■	■	■				
Remote Third-Party HMI	■	■	■	+	■	■	■	■	■	■	■				

## Features

Protocol Redundancy (DNP3 and IEC 60870-5-101/104 Server)				+	■	■	■	■	■	■	■				
Primary and Standby LAN Support	+/#	+/#	+/#	+	■	■	■	■	■	■	■	■	■	■	■
Optoisolated Inputs/Programmable Outputs				+	■ <sup>1</sup>	■ <sup>1</sup>	■ <sup>1</sup>	■	+	+	■ <sup>1</sup>	+	+	+	+
IEC 61131 Logic Engine				+	■	■	■	■	■	■	■				
Cybersecurity Management	■	■	■	+	■	■	■	■	■	■	■				
Real-Time Operating System				+	■	■	■	■	■	■	■	■	■	■	■
Web-Based HMI	■	■	■	+	+	+	+	+	+		+				
Touchscreen Display	+/#	+/#	+/#	+/#					+			+		+	
LCD												■	■	■	

■ Standard feature + Model option #Third-party software required <sup>1</sup>Alarm contact only

Hardware	SEL-3355	SEL-3360E	SEL-3360S	SEL-3350	SEL-3555	SEL-3560E	SEL-3560S	SEL-3530-4	SEL-2240	SEL-3505/3505-3	SEL-3533	SEL-2411	SEL-2411P	SEL-2414	SEL-2440
Intel Xeon Quad-Core 64-Bit CPU	■	■	■		■	■	■								
Intel Atom Quad-Core 64-Bit CPU				■					■						
Power PC Single-Core CPU								■		■					
Maximum Error-Correcting Code (ECC) RAM (GB)	64	64	64	8	64	64	64	1	4	0.5					
Supports Independent Displays With Digital Audio	■	■	■	■	■	■	■								
Analog Audio Ports: Line In, Line Out, Microphone	■	■	■												
Front USB Ports	■	■	■	■	■	■	■								
Rear USB Ports	■	■	■	■	■	■	■		■						
Front RJ45 Ethernet Ports				1					+						
Rear Ethernet Ports	2	2	2	4	2	2	2	2	3	2		2	2		2
Fiber-Optic Rear Ethernet Ports				+				+	+	+		+	+		+
Additional Ethernet Ports, Copper RJ45, or Fiber-Optic SFP	8	4			8	4									
Dedicated Serial Ports	2	2	2		2	2	2								
Configurable Serial Ports				16	6	6		4	4	4/3					
Expansion Serial Ports	24	12		32	18	6									
IRIG-B Input	■	■	■		■	■	■		■			■	■	■	■
IRIG-B Output	+	+		■	+	+		■	■	■					
19" Rack Mount	■			■	■			■	■			+	+	+	+
Panel Mount	+			+	+			+	+			+	+	+	+
Wall Mount		■	■			■	■								
Conduction Cooled Wall Mount		+	+			+	+								
PCI/PCIe Expansion Slots	5	2			3	1									
SSDs (2.5" SATA, 32 GB–7.68 TB Drive Options)	4	2	2	2	4	2	2								
High-Voltage 125–250 Vdc, 120–240 Vac Power Supply	■	■	+	■	■	■	+	■	■			■	■	■	■
Medium-Voltage 48–125 Vdc, 120 Vac Power Supply				■				■				■	■	■	■
Low-Voltage 48 Vdc Power Supply	■	■	+		■	■	+								
Low-Voltage 24–48 Vdc Power Supply				■					+	+		+	+		+
12–24 Vdc Power Supply										■					
12 Vdc Power Supply			■				■								
Secondary Power Supply	+		+		+		+								
Hot-Swappable Power Supplies	■		■	+	■		■								
Alarm Contact, Alarm LED, Watchdog	■	■	■	■	■	■	■	■	■	■	■	■	■	■	■
Configurable Universal Control Input				■											
Programmable LEDs	3	3	3	4	3	3	3		2			23	15	23	19
Intel Active Management Technology (AMT) v11.8	■	■	■												
Infineon Trusted Platform Module (TPM) v2.0 (Hardware)	■	■	■	■	■	■	■	■							

■ Standard feature + Model option

Supported Operating Systems and Hypervisors	SEL-3355	SEL-3360E	SEL-3360S	SEL-3350	SEL-3555	SEL-3560E	SEL-3560S	SEL-3530-4	SEL-2240	SEL-3505/3505-3	SEL-3533	SEL-2411	SEL-2411P	SEL-2414	SEL-2440
SEL Real-Time Automation Controller (RTAC)				+	■	■	■	■	+	■	■				
SEL Blueframe	+	+	+	+											
Linux (RHEL, SUSE, Ubuntu)	††	††	††	††											
Microsoft Windows IoT Enterprise LTSC	+	+	+	+											
Microsoft Windows Server Standard	+	+	+	+											
Linux KVM	†	†	†	†											
Microsoft Hyper-V	†	†	†	†											
VMware ESXi	†	†	†												

### Supported Protocols

SEL ASCII				+	■	■	■	■	■	■	■				
SEL Fast Messages				+	■	■	■	■	■	■	■				
SEL MIRRORING BITS® Communications					■	■	■	■	■	■	■	■	■	■	■
CDC Type II				+	■	■	■	■	■	■	■				
CP 2179				+	■	■	■	■	■	■	■				
DNP3				+	■	■	■	■	■	■	■	+	■	+	+
DNP3 LAN/WAN				+	■	■	■	■	■	■	■	+	■	+	+
EtherCAT® (SEL-2240 Field Bus I/O Only)									■						
EtherNet/IP				+	■	■	■	■	■	■	■				
File Transfer Protocol (FTP)/Secure FTP (SFTP)				+	■	■	■	■	■	■	■	■	■	■	■
IEC 60870-5-101				+	■	■	■	■	■	■	■				
IEC 60870-5-103				+	■	■	■	■	■	■	■				
IEC 60870-5-104				+	■	■	■	■	■	■	■				
IEC 61850 GOOSE				+	+	+	+	+	+	+	+	+		+	+
IEC 61850 Manufacturing Message Specification (MMS)				+	+	+	+	+	+	+	+	+		+	+
IEEE C37.118				+	■	■	■	■	■	■	■				
LG 8979				+	■	■	■	■	■	■	■				
Lightweight Directory Access Protocol (LDAP)				+	■	■	■	■	■	■	■				
Modbus RTU				+	■	■	■	■	■	■	■	■	■	■	■
Modbus TCP				+	■	■	■	■	■	■	■	■	■	■	■
MQTT				+	■	■	■	■	■	■	■				
Network Time Protocol (NTP)				+	■	■	■	■	■	■	■				
OPC Unified Architecture (UA)				+	+	+	+		+	+					
Parallel Redundancy Protocol (PRP)	+	+	+	+	■	■	■	■	■	■	■	■	■	■	■
Precision Time Protocol (PTP)				+	■	■	■	■	■	■	■	■		■	■
Secure Shell (SSH)				+	■	■	■	■	■	■	■				
SES-92				+	■	■	■	■	■	■	■				
Simple Mail Transfer Protocol (SMTP)/Email Notification				+	■	■	■	■	■	■	■				
Simple Network Management Protocol (SNMP)				+	■	■	■	■	■	■	■				
Simple Network Time Protocol (SNTP)				+	■	■	■	■	■	■	■	■	■	■	■
Telnet				+	■	■	■	■	■	■	■	■	■	■	■

■ Standard feature    + Model option    † Supported for customer installation    f May be created using settings



# SEL Network Communications Solutions

[selinc.com/products/categories/networking-communications](http://selinc.com/products/categories/networking-communications)

SEL offers a simple, reliable communications architecture to tie together the protection, automation, control, and monitoring devices in a power system network.

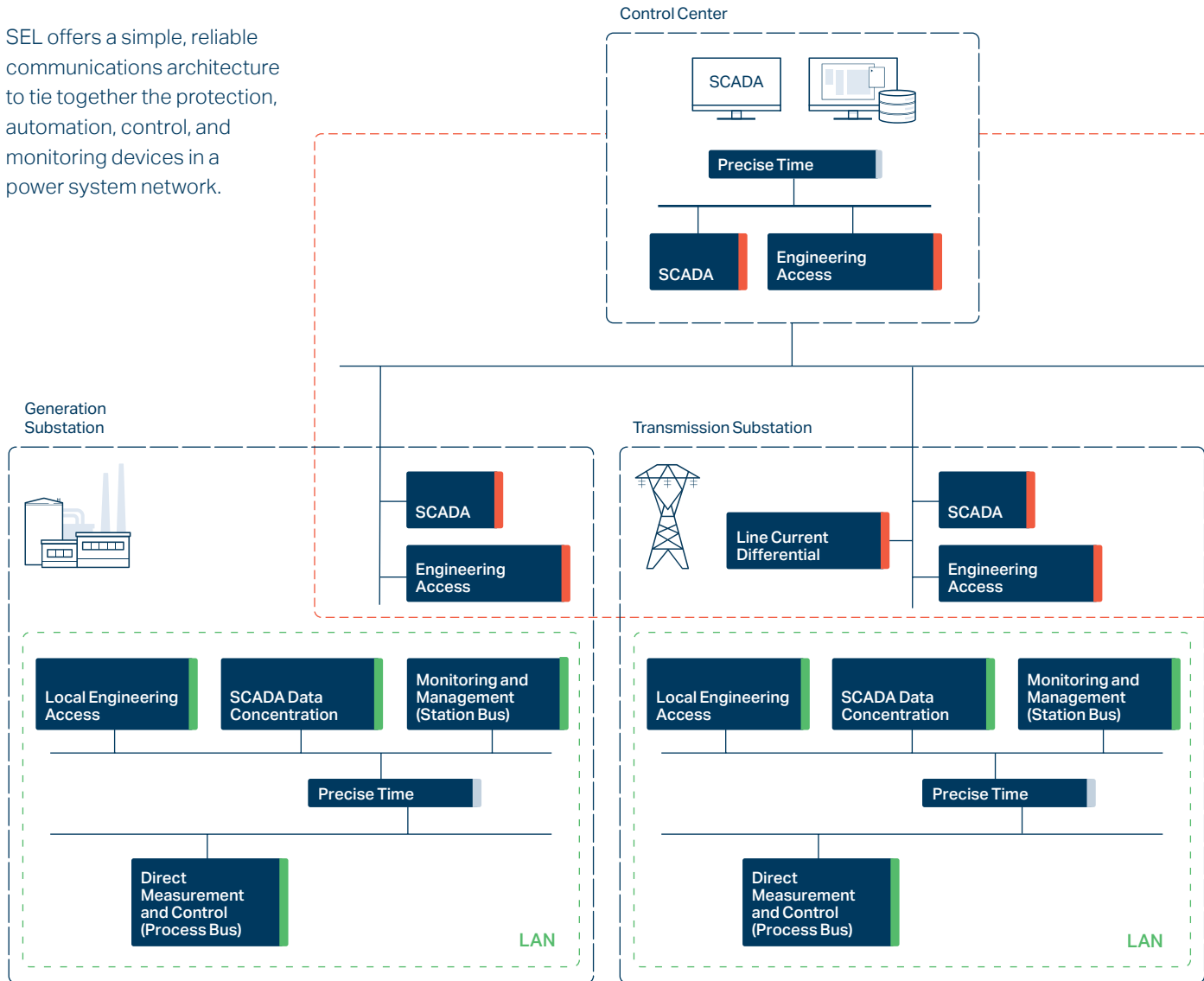

## Wide-Area Networks (WANs)

The SEL operational technology (OT) WAN circuit aggregation solution supports a variety of transport technologies, from DS1/E1 to packet transport, and helps preserve the performance characteristics of time-division multiplexing (TDM) for critical applications, regardless of the deployed technology. The SEL ICON® offers a rugged, flexible solution with a 20-year life cycle, extending the network's lifetime and improving its reliability.

## Local-Area Networks (LANs)

SEL Ethernet switches and security gateways facilitate reliable, predictable, and secure connectivity between different devices for critical applications. Our rugged solutions are optimized for OT networking. They simplify network engineering, improve cybersecurity, ensure dependable performance, and support critical infrastructure with economical devices designed for 20 years of operation.

## Field-Area Networks (FANs)

The SEL-3031 Serial Radio Transceiver and SEL-3061 Cellular Router provide robust wireless communications for electric utilities to achieve optimized situational awareness. Our wireless solutions can be seamlessly integrated with SCADA applications, like recloser controls, capacitor bank controls, voltage regulator controls, fault indicators, sensors, and other IEDs.

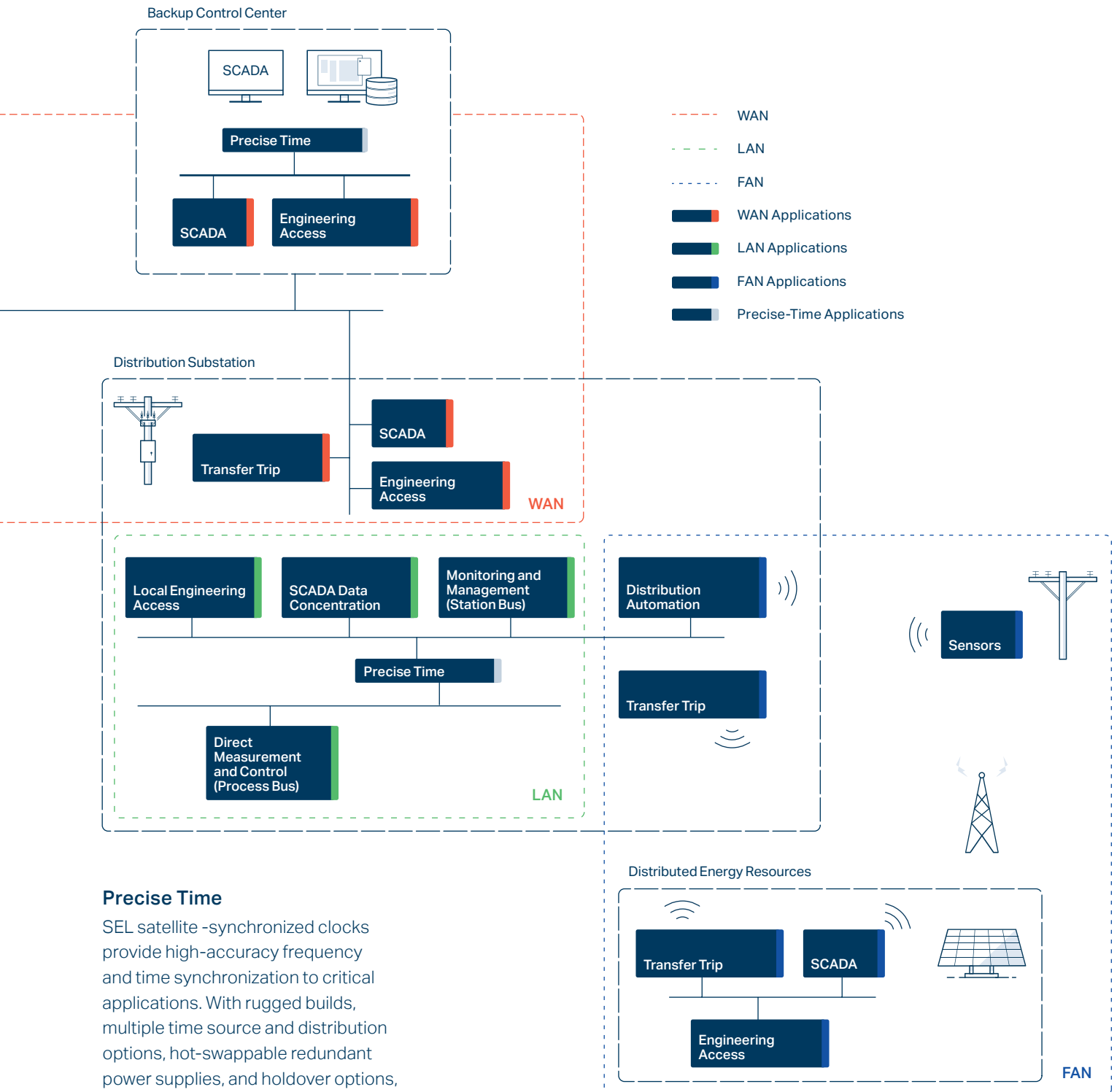

## Precise Time

SEL satellite -synchronized clocks provide high-accuracy frequency and time synchronization to critical applications. With rugged builds, multiple time source and distribution options, hot-swappable redundant power supplies, and holdover options, SEL clocks provide flexible and resilient precise-time solutions for critical infrastructure, like electric utilities, data centers, and public safety.



# WAN and LAN Networks

[selinc.com/products/categories/networking-communications](http://selinc.com/products/categories/networking-communications)

SEL devices combine the connectivity, performance, cybersecurity, and ruggedness required for WAN and LAN applications.

## Solutions

- Operational technology (OT) networking:
  - Programmable networks and software-defined networking (SDN)
  - Managed networks and the Rapid Spanning Tree Protocol (RSTP)
- WAN circuit aggregation
- SONET/T1/E1 multiplexing

## Applications

- Teleprotection systems
- Analog leased-line service migration
- IT/OT convergence
- Engineering access
- SCADA and distributed control systems
- Network time synchronization
- IEC 61850 digital secondary systems
- Special protection systems
- Microgrids
- Distributed renewables
- Remedial action schemes
- Facility-related control systems
- NERC CIP
- Land mobile radio (LMR) systems

## Video

OT Software-Defined Networking: Purpose-Engineered for Critical Infrastructure

[video.selinc.com/detail/video/1726869976932833649](http://video.selinc.com/detail/video/1726869976932833649)

## Webinars

Best Practices for Successful IT/OT Network Convergence

[selinc.com/events/webinar/128773](http://selinc.com/events/webinar/128773)

Redefining Ethernet Performance With Software-Defined Networking

[selinc.com/events/webinar/130273](http://selinc.com/events/webinar/130273)

Lower Your Costs With SEL ICON®: Decades of WAN Transport Flexibility

[selinc.com/events/webinar/140867](http://selinc.com/events/webinar/140867)

Stay TDM or Move to Packet? Do Both With the SEL ICON

[selinc.com/events/on-demand-webinar/138942](http://selinc.com/events/on-demand-webinar/138942)

Automate SDN Configuration With RTAC and IEC 61850 Files

[selinc.com/events/on-demand-webinar/137644](http://selinc.com/events/on-demand-webinar/137644)

## Technical Papers

Using Software-Defined Networking to Build Modern, Secure IEC 61850-Based Substation Automation Systems

[selinc.com/api/download/130126](http://selinc.com/api/download/130126)

Deterministic Communications for Protection Applications Over Packet-Based Wide-Area Networks

[selinc.com/api/download/121072](http://selinc.com/api/download/121072)

Taking Full Control of Your Process Bus LAN Using New Ethernet Packet Transport Technologies

[selinc.com/api/download/119756](http://selinc.com/api/download/119756)

## SDN News

[selinc.com/products/sdn/news](http://selinc.com/products/sdn/news)

## ICON News

[selinc.com/products/icon/news](http://selinc.com/products/icon/news)



## Customer Stories

Belgium Integrates Offshore Wind Power Into European Grid

[selinc.com/featured-stories/elia](http://selinc.com/featured-stories/elia)

EPR Modernizes Their Multinational Transmission System

[selinc.com/highlights/epr-siepac-modernization](http://selinc.com/highlights/epr-siepac-modernization)

Defending Critical Substation Communications in Slovenia

[selinc.com/highlights/eles](http://selinc.com/highlights/eles)

Creating a Better Future: Innovative Substation Modernization in the Philippines

[selinc.com/highlights/davao-light](http://selinc.com/highlights/davao-light)

## White Papers

Software-Defined Networking Changes the Paradigm for Mission-Critical Operational Technology Networks

[selinc.com/api/download/118416](http://selinc.com/api/download/118416)

Leveraging SEL Ecosystem for NERC CIP-015 Compliance

[selinc.com/api/download/140729](http://selinc.com/api/download/140729)

## Related Materials

OT SDN

[selinc.com/solutions/ot-sdn](http://selinc.com/solutions/ot-sdn)

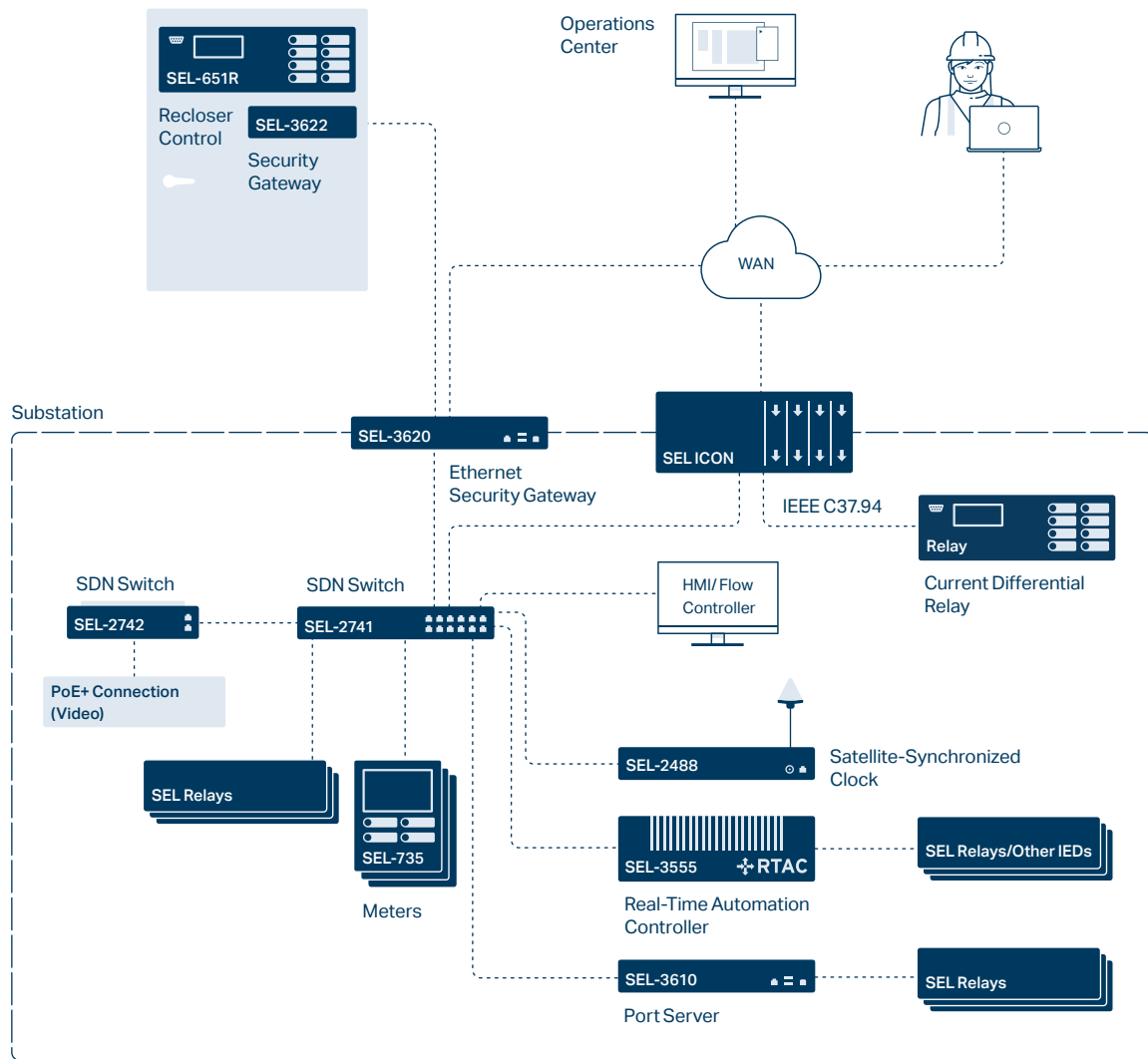

### Example System Diagram

Combine SEL LAN and WAN devices with other SEL protection, automation, and control products for a comprehensive solution.



### SEL ICON Integrated Communications Optical Network

The ICON is a WAN multiplexing and circuit aggregation solution optimized for industrial and utility applications. By combining time-division multiplexing (TDM) and Ethernet transport options with a comprehensive range of data interfaces, the ICON makes it easy to migrate legacy network technologies to a packet-based solution.



### SEL-2731 Ethernet Switch

The SEL-2731 is an OT SDN and Rapid Spanning Tree Protocol (RSTP) managed Ethernet switch that is optimized for OT environments, supporting critical infrastructure applications.



### SEL-2741 Ethernet Switch

The SEL-2741 is a 24-port, multilayer LAN Ethernet switch that supports deny-by-default, zero-trust OT SDN and RSTP. It is designed to perform reliably in the harshest environments found in critical infrastructure.



### SEL-2740S Software-Defined Network Switch

The SEL-2740S is the industry's first field-hardened SDN-enabled switch and improves cybersecurity and Ethernet performance in mission-critical applications.



### SEL-2742 Ethernet Switch

The SEL-2742 is a 12-port, DIN-rail mount SDN switch for industrial environments. It combines with SEL-5056 Network Management System (NMS) software to simplify network engineering and improve LAN security.



### SEL-2743 Ethernet Switch **NEW**

The SEL-2743 is an 8-port OT SDN and RSTP managed Ethernet switch. Combining powerful performance, a small form factor, Power over Ethernet Plus (PoE+), and an economical price, it's ideal for OT networks for most industrial and electric utility communications applications.



### SEL-2744 Ethernet Switch **NEW**

The SEL-2744 is a 10-port OT SDN and RSTP aggregation Ethernet switch. With two 10 Gbps ports, dual power supplies, and PoE+, it's well suited for IT/OT convergence at electric utilities.



### SEL-3620 Ethernet Security Gateway or SEL-3622 Security Gateway

The gateways each function as a router, VPN endpoint, and firewall device. They can provide secure and proxy user access for serial- and Ethernet-based IEDs.



### SEL-2725 Five-Port Ethernet Switch

The SEL-2725 allows you to easily connect devices to Ethernet networks.

Applications	SEL ICON	SEL-3620	SEL-3622	SEL-2725	SEL-2731	SEL-2740S	SEL-2741	SEL-2742	SEL-2743	SEL-2744
SONET and Ethernet WAN	■									
Ethernet LAN	■	■	■	■	■	■	■	■	■	■
E1 and T1 Transport	■									
Precise Time Distribution	■	■	■		■	■	■	■	■	■
Engineering Access Control		■	■		■ <sup>1</sup>	■ <sup>1</sup>	■ <sup>1</sup>	■ <sup>1</sup>	■ <sup>1</sup>	■ <sup>1</sup>
Connect Multiple Wired-Ethernet Devices to Network	■			■	■	■	■	■	■	■
Convert Wired 10/100BASE-T Ethernet to Fiber-Optic 100BASE-FX Ethernet	■	■	■	■	■	■	■	■	■	■
Convert Serial Links to Ethernet Links		■	■							

## Features

Cryptography (Encryption and Authentication)		■	■							
User-Based Accounts	■	■	■		■ <sup>2</sup>	■ <sup>2</sup>	■ <sup>2</sup>	■ <sup>2</sup>	■ <sup>2</sup>	■ <sup>2</sup>
Centralized Authentication Via Lightweight Directory Access Protocol (LDAP)	■ <sup>3</sup>	■	■		■ <sup>2</sup>	■ <sup>2</sup>	■ <sup>2</sup>	■ <sup>2</sup>	■ <sup>2</sup>	■ <sup>2</sup>
Centralized Authentication Via Remote Authentication Dial-In User Service (RADIUS)		■	■							
Single Sign On (SSO)	■ <sup>3</sup>									
Deny-by-Default Firewall		■	■		■ <sup>4</sup>	■ <sup>4</sup>	■ <sup>4</sup>	■ <sup>4</sup>	■ <sup>4</sup>	■ <sup>4</sup>
Import/Export Configuration Files	■	■	■		■ <sup>2</sup>	■ <sup>2</sup>	■ <sup>2</sup>	■ <sup>2</sup>	■ <sup>2</sup>	■ <sup>2</sup>
VPN		■	■							
Syslog Logging	■	■	■		■	■	■	■	■	■
Network Management System (NMS) Software	■				■	■	■	■	■	■
GPS Receiver	■									
Power over Ethernet Plus (PoE+)							■	■	■	■
Real-Time Latency Monitor	■									
Spanning Tree Protocol (STP)	■	■	■		■		■		■	■
Rapid Spanning Tree Protocol (RSTP)	■				■		■		■	■
Multiple Spanning Tree Protocol (MSTP)	■									
VLANs	■	■	■		■	■	■	■	■	■
Ethernet Class of Service (CoS)	■				■	■	■	■	■	■

## Ethernet Ports, Connector

### Quantities

Copper 10/100BASE, RJ45	0–8 <sup>5</sup>	3	3	3 or 4	0–24	0–20	0–24	2–8	0–8	0–8
Fiber-Optic 100BASE, LC	0–8 <sup>6</sup>	2	2	1 or 2	0–24	0–20	0–24	0–6	0–8	0–8
Copper 1000BASE, RJ45	0–8 <sup>5</sup>				0–8	0–4	0–24	0–4	0–8	0–10
Fiber-Optic 1000BASE, LC	4 <sup>6</sup> /0–8 <sup>7</sup>				0–8	0–4	0–24	0–4	0–8	0–10
Fiber-Optic 10GE, LC										0–2
Small Form-Factor Pluggable (SFP) Cages	4 <sup>6</sup> /0–8 <sup>7,8</sup>				0–24		0–24		0–8	0–10

<sup>1</sup>Communication management for engineering access.

<sup>2</sup>SEL-5056 NMS software, when using SDN technology, provides centralized authentication, user-based accounts, and import/export configuration files.

<sup>3</sup>SEL-5052 Server NMS Software provides LDAP centralized authentication and SSO for the ICON.

<sup>4</sup>Deny-by-default network access control.

<sup>5</sup>SEL ICON has the option to support 8 copper and 8 SFP ports across two Ethernet Bridging Access Modules (EBAMs).

<sup>6</sup>SEL-8022-01 Enhanced Protected Line Module supports 2 fiber-optic Gigabit interfaces.

<sup>7</sup>SEL-8036-01 Ethernet Bridging Access Module supports 4 fiber-optic 100BASE-FX/Gigabit interfaces.

<sup>8</sup>SEL ICON uses SFP cages for SONET and GigE fiber-optic interfaces.



# Wireless Communications

[selinc.com/products/categories/networking-communications/#wireless-communications](http://selinc.com/products/categories/networking-communications/#wireless-communications)

Wireless communications extend networks in areas where wired communications networks are not available or are cost-prohibitive. SEL wireless devices use radio signals to communicate and send data over the air, eliminating the need for traditional cabling.

## Applications

- Cellular router for remote connectivity
- Serial radio for protection schemes

## Technical Papers

Expanding Protection and Control Communications Networks With Wireless Radio Links

[selinc.com/api/download/121073](http://selinc.com/api/download/121073)

Overcoming the Challenges of License-Free Radio Communications With Secure Cellular Radios

[selinc.com/api/download/140452](http://selinc.com/api/download/140452)

## Webinar

Improve System Visibility and Reliability With SEL's Wireless Fault Indication System

[selinc.com/events/on-demand-webinar/134158](http://selinc.com/events/on-demand-webinar/134158)



## Customer Story

SCADA System Sheds Light on Texas Utility's Power System

[selinc.com/solutions/success-stories/scada-in-texas](http://selinc.com/solutions/success-stories/scada-in-texas)

## Video

Communication Made Easy Over Difficult Terrain

[video.selinc.com/detail/video/767833630001](http://video.selinc.com/detail/video/767833630001)



## SEL-3061 Cellular Router

The SEL-3061 provides secure, remote access for devices using public cellular radio networks. It supports 4G LTE.

## Example System Diagram

Improve operation efficiency with advanced network architectures.

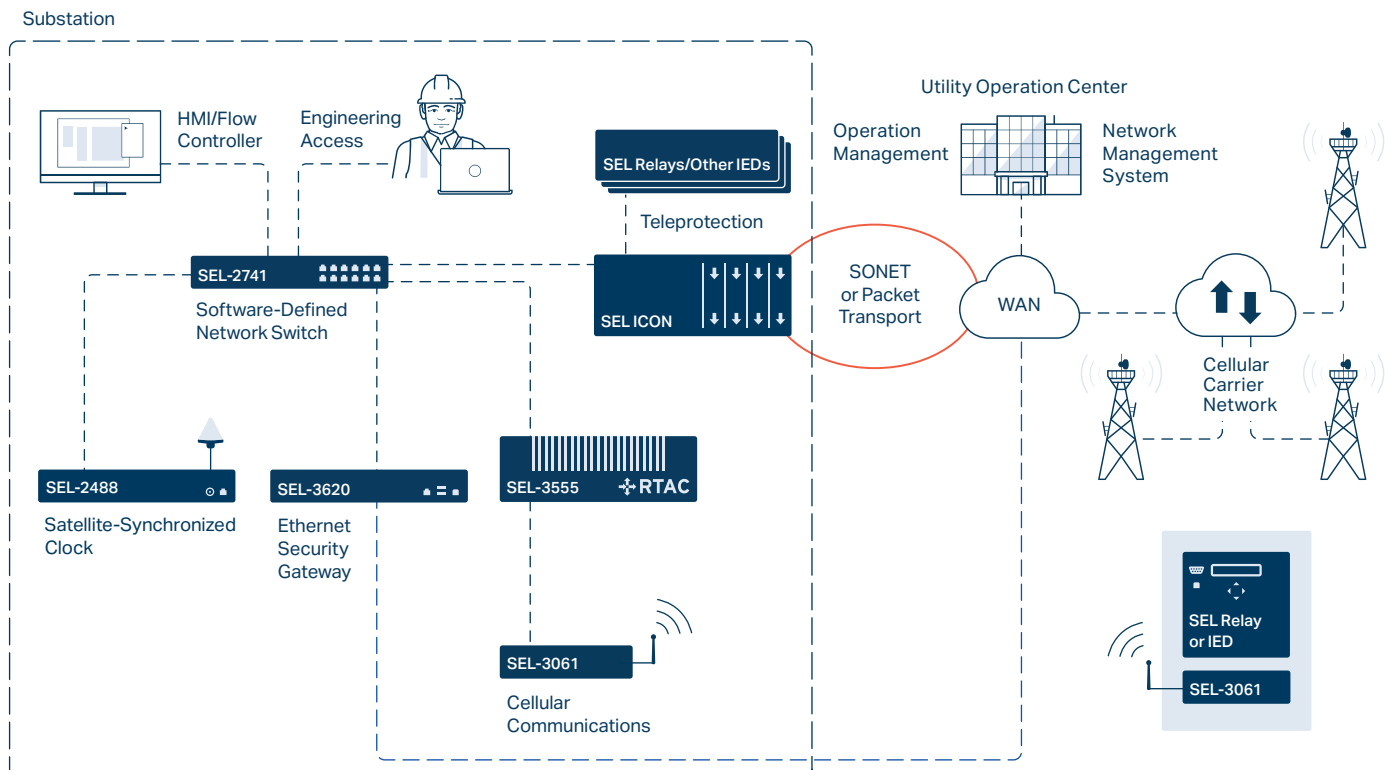



## SEL-3031 Serial Radio Transceiver

The SEL-3031 is a 900 MHz ISM serial data radio that supports point-to-point (P2P) and point-to-multipoint (P2MP) operational modes. In P2P mode, the SEL-3031 supports three serial data ports in one radio channel. It can protect critical data from malicious attacks with the optional encryption card.

### Example System Diagram

Economical communications solutions for remote locations and controls

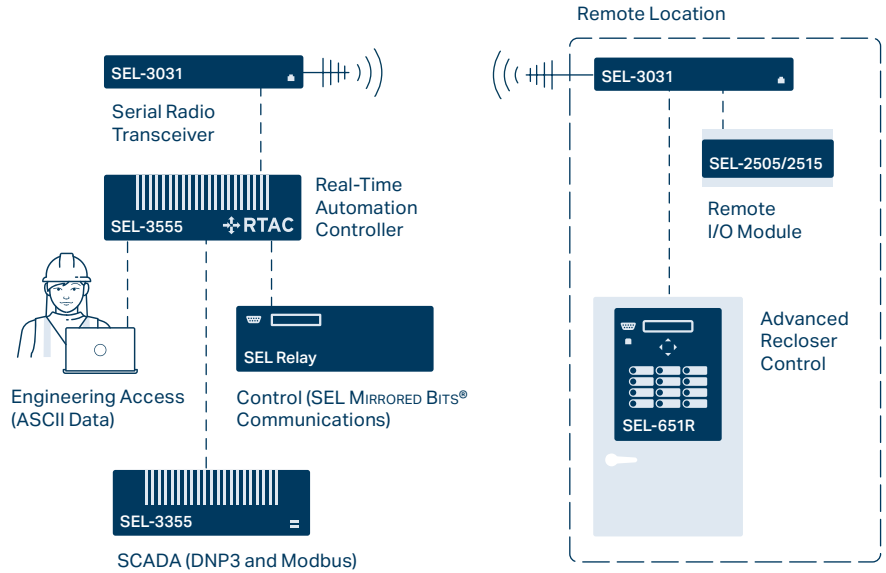

	SEL-3031	SEL-3061
<b>Applications</b>		
Wireless Communications for SCADA	■	■
High-Speed Teleprotection	■	
Distribution Automation	■	■
Wireless Communications for Synchrophasor Data	■	■
Substation-to-Substation Communications Link		■
Wireless Communications for Distributed Generation	■	■
Permanent Wireless Cable Replacement	■	■
Remote Engineering Access	■	■
Short-Range Engineering Access	■	■
LAN Extension		■
Wireless Backhaul Communications for Fault and Load Transmitters		■
<b>Setup Method</b>		
USB Port	■	
Secure Web Interface Via Ethernet Port		■
Wireless Configuration	■	■
Simple Network Management Protocol (SNMP)		■

	SEL-3031	SEL-3061
<b>Features</b>		
915 MHz ISM Band (License-Free)	■	
Serial Communication	■	■
Ethernet Communication		■
Low Latency for Teleprotection	■	
Compatible With SEL MIRRORRED BITS® Communications	■	
Compatible With Modbus	■	■
Compatible With DNP3 and Typical Byte-Oriented Protocols	■	■
Encryption	<i>f</i>	■
Point-to-Multipoint Capability	■	
Cellular Capability		■
EIA-232 Port (Quantity)	3	1
Wired EIA-485 Port	+	
High Maximum Throughput (1 Mbps or Greater)		■
Device Status LEDs	■	■
Visible Link Quality Indicator		■
■ Standard feature + Model option <i>f</i> With SEL-3044 Encryption Card option		



# Precise Time

[selinc.com/products/categories/precise-time](http://selinc.com/products/categories/precise-time)

SEL precise-time products keep critical infrastructure devices synchronized to the microsecond. They offer resilience and security that meet the rigorous demands of critical infrastructure while supporting a range of industry protocols. With tough solid-state hardware, SEL precise-time products are engineered for reliability. Backed by our world-class sales and customer service team, these products provide a low cost of ownership and minimize the risk of disruption.

## Applications

- Utility and industrial facilities
- Manufacturing
- Military bases
- Transportation systems
- Land mobile radio (LMR) systems
- Emergency services

## Customer Story

Emergency Radio—A Community Effort

[selinc.com/highlights/whitman-county-emergency-communications](http://selinc.com/highlights/whitman-county-emergency-communications)

## Technical Papers

Understanding the Impact of Time Inaccuracy on Synchrophasors, Traveling-Wave Fault Locating, and Line Current Differential Protection

[selinc.com/api/download/138657](http://selinc.com/api/download/138657)

It's About Time—Considerations and Requirements for DSS and Line Current Differential Applications

[selinc.com/api/download/138274](http://selinc.com/api/download/138274)

Using Wide-Area Precise Time Distribution to Increase Dependability and Security of Substation Time Synchronization

[selinc.com/api/download/136425](http://selinc.com/api/download/136425)



### SEL-2488 Satellite-Synchronized Network Clock

The SEL-2488 receives multiple time signals and distributes precise frequency and time via 10 MHz, IRIG-B, NTP, and PTP outputs with  $\pm 40$  ns accuracy.



### SEL-2407<sup>®</sup> Satellite-Synchronized Clock

The SEL-2407 is a half-rack satellite clock with a time display that provides IRIG-B outputs with  $\pm 100$  ns accuracy.



### SEL-2401 Satellite-Synchronized Clock

The SEL-2401 is a compact satellite clock that provides an IRIG-B output with  $\pm 100$  ns accuracy.



### SEL-3400 IRIG-B Distribution Module

The SEL-3400 verifies two IRIG-B inputs and distributes demodulated IRIG-B output for up to 240 devices.



### SEL-3405 High-Accuracy IRIG-B Fiber-Optic Transceiver

SEL-3405 transceivers send delay-compensated demodulated IRIG-B signals up to 4 km (2.5 mi).



### SEL-9524 GNSS Antenna

The SEL-9524 is a rugged and reliable antenna for GNSS devices in critical infrastructure applications.

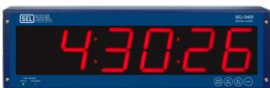

### SEL-3401 Digital Clock

The SEL-3401 provides a highly visible time display for use anywhere there are time-critical functions set by IRIG-B synchronization signals.



### SEL-9929 Satellite-Synchronized Clock Display Kit

The SEL-9929 kit includes a satellite-synchronized clock, a large digital clock display, and all accessories.



### SEL ICON<sup>®</sup> Integrated Communications Optical Network

The ICON provides precise time distribution over WANs, with an accuracy of 1  $\mu$ s with a variety of input and output protocols.

	SEL-2401	SEL-2407®	SEL-3400	SEL-3401	SEL ICON®	SEL-2488
<b>Applications</b>						
Time Source for Substation and Industrial Applications	■	■	■		■	■
Time Source for Land Mobile Radio (LMR) Systems and Public Safety Answering Points (PSAPs)						■
Digital Secondary Systems (Sampled Values)					■	■
Time Source for Phasor Measurement Unit (IEEE C37.118.1-2011 Synchrophasors)	■	■	■		■	■
Time Source for Recloser	■					
Time Source for Line Current Differential Protection, Traveling-Wave Fault Locating, and Time-Synchronized Event Reporting	■	■	■		■	■
Network Time Synchronization Applications Using the Network Time Protocol (NTP)						■

### Time Sources and Time Distribution

Demodulated IRIG-B Outputs (Quantity)	1	6	12	4 <sup>1</sup>	4	9
Modulated IRIG-B Outputs (Quantity)		1				up to 4
Optional 10 MHz Frequency Outputs (Quantity)						6
GPS Satellite Tracking	■	■			■	■
GLONASS Satellite Tracking (Verification Only)						■
Demodulated IRIG-B Input			■	■	■	
Synchronized Pulse Output	■	■			■	■
NTP Server						■
IEEE 1588-2008 Precision Time Protocol (PTP) Input (With ITU-T G.8275.1 Telecom Profile)					+	+
IEEE 1588-2008 PTP Output (With IEEE C37.238-2011/2017 Power System and IEC/IEEE 61850-9-3:2016 Power Utility Automation Profiles)					+	+

### Features

Large, 76.2 mm (3.0 in) Tall LED Display for Long-Distance Viewing (61 m [200 ft])				■		
14 mm (0.56 in) Tall Display		■	■			■
Rack-Mount Hardware		■	■	+	+	■
Panel-Mount or Wall-Mount Hardware		■	+	■	+	+
Universal Power Supply		■	■			
Dual, Redundant, Hot-Swappable Power Supplies (High-Voltage or Low-Voltage)					■	■
Parallel Redundancy Protocol (PRP) and Ethernet Failover Support						■
Secure Web Interface for Configuration						■
Serial Ports for Configuration	■	■				
User-Based Accounts					■	■
TCXO Holdover	■	■			■	■
OEXO, DOEXO, or Rubidium High-Stability Holdover						+
Cable Delay Compensation			■		■	■ <sup>1</sup>
IEEE C37.90 and IEC 60255 Surge and Environmental Standards Compliance	■	■	■	■	■	■

### Accuracy

Average Accuracy (ns)	±100	±100				±40
Peak Accuracy (ns)	±500	±500			±1,000	±100

■ Standard feature + Model option/accessory <sup>1</sup>SEL-2488 includes antenna cable delay compensation



# Transceivers and Adapters

[selinc.com/products/categories/cables-accessories](http://selinc.com/products/categories/cables-accessories)

Many SEL devices come with standard or optional fiber-optic communications ports. Transceivers convert between copper and fiber optics or between other communications interface standards.

## Applications

- Single- or multimode fiber
- Distances ranging from 1 m (3.28 ft) to 110 km (68.35 mi)

## Related Material

Fiber-Optic Products and Applications  
[selinc.com/api/download/2848](http://selinc.com/api/download/2848)

Connector and Wavelength	SEL-2800	SEL-2810	SEL-2812	SEL-9220	SEL-2814	SEL-2815	SEL-2820	SEL-2824	SEL-2829	SEL-2830	SEL-2831	SEL-2894
V-Pin, 650 nm	■	■					■					
ST, 850 nm			■	■	■	■		■				■
ST, 1,300 nm									■	■		
ST, 1,550 nm											■	

## Fiber Compatibility

200 µm Core Multimode Fiber (SEL-C805)	■	■	■	■	■	■	■	■				
50 or 62.5 µm Core Multimode Fiber (SEL-C807, SEL-C808)			■	■	■	■		■				■
9 µm Core Single-Mode Fiber (SEL-C809)									■	■	■	

## Electrical Features

EIA-232 Asynchronous Serial Data	■	■	■		■	■			■	■		■
EIA-485 Asynchronous Serial Data				■			■	■				
DTE/DCE Switch					■	■			■	■	■	
IRIG-B Transfer With Data		■	■	■								
Hardware Flow Control Lines With Data					■			■				
Power From Electrical Port Pins	■	■	■	■	■	■			■	■	■	■
External Power Jack or Terminals					■		■	■				

## Distances

Minimum (metric)	1 m	1 m	1 m	1 m	1 m	2 km	1 m	1 m	1 m	16 km	16 km	1 m
Minimum (U.S.)	3.28 ft	3.28 ft	3.28 ft	3.28 ft	3.28 ft	1.24 mi	3.28 ft	3.28 ft	3.28 ft	9.94 mi	9.94 mi	3.28 ft
Maximum (metric)	500 m	500 m	4 km	4 km	4 km	15 km	500 m	4 km	23 km	80 km	110 km	2 km
Maximum (U.S.)	0.3 mi	0.3 mi	2.48 mi	2.48 mi	2.48 mi	9.3 mi	0.3 mi	2.48 mi	14.3 mi	49.7 mi	68.3 mi	1.2 mi

■ Standard feature



### SEL-2800/2815 Fiber-Optic Transceivers

Improve safety, signal integrity, and reliability of EIA-232 communications by using multimode SEL-2800 or SEL-2815 transceivers instead of wire.



### SEL-2810/2812/2814 Fiber-Optic Transceivers

Use EIA-232 multimode fiber-optic transceivers instead of wire. The SEL-2810 and SEL-2812 support IRIG-B time signals, while the SEL-2814 works with hardware flow control signals.



### SEL-2829/2830/2831 Single-Mode Fiber-Optic Transceivers/Modems

Apply the SEL-2829, SEL-2830, or SEL-2831 to use two optical fibers instead of wire to transfer bidirectional serial data.



### SEL-2820/2824 Multimode Fiber-Optic EIA-485 Transceivers

Apply an SEL-2820 or SEL-2824 to safely add isolated segments to multidrop and point-to-point EIA-485 networks.

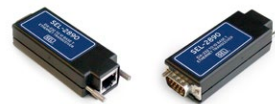

### SEL-2890 Ethernet Transceiver

Add Ethernet connectivity to an SEL device using its EIA-232 serial port with the SEL-2890.



### SEL-9220 Fiber-Optic Adapter for SEL-300 Series Relays

Convert the EIA-485 port of an SEL-300 series relay to a point-to-point fiber-optic port with the SEL-9220.



### SEL-2894 Interface Converter

Apply the SEL-2894 to transfer SEL MIRRORED BITS® communications via an IEEE C37.94 fiber-optic link through a communications multiplexer.



### SEL-2886 EIA-232 to EIA-485 Interface Converter

Connect EIA-232 devices to an EIA-485 network with SEL-2886 converters.



### SEL-2902 RJ45 to DB-9 Adapter Panel

Easily retrofit RJ45 ports to DB-9 connectors using the SEL-2902 adapter panel. The SEL-2902 allows you to retain existing serial cables and transceivers when upgrading from an SEL-3530 Real-Time Automation Controller (RTAC) or SEL-2020/2030/2032 Communications Processor to an SEL-3300 series computing platform.



# Cables

[selinc.com/products/categories/cables-accessories](http://selinc.com/products/categories/cables-accessories)

SEL manufactures high-quality cables for connecting a variety of devices. Each cable is quality-tested to ensure reliability and proper operation. Choose the cable types and lengths to match your applications using the SEL-5801 Cable Selector program.

## Applications

- GPS and radio antenna connections and IRIG-B time distribution
- Serial communications over long distances without risk of electromagnetic interference
- Adaption and connection to USB ports

## Related Material

SEL-5801 Cable Selector  
[selinc.com/5801-selector](http://selinc.com/5801-selector)



### SEL-C804 Multimode Arc-Flash Detection Fiber-Optic Cable

Use SEL-C804 cables with SEL-751 and SEL-851 Feeder Protection Relays and with SEL-710-5 Motor Protection Relays.



### SEL-C805 200 μm Multimode Fiber-Optic Cable

Connect V-pin or ST ports with SEL-C805 cable assemblies.



### SEL-C807 62.5/200 μm Multimode Fiber-Optic Cable

Use SEL-C807 cable assemblies to connect ST or LC ports.



### SEL-C808 62.5/125 μm Multimode Fiber-Optic Cable

Connect ST, SC, or LC ports with SEL-C808 cable assemblies.



### SEL-C809 9 μm Single-Mode Fiber-Optic Cables

Use SEL-C809 cable assemblies to connect ST, SC, or LC ports.



### Category 5e Ethernet

Apply high-quality, shielded twisted-pair (STP) Category 5e Ethernet cables for copper Ethernet connections.



### Coaxial Cables

Use SEL Coaxial Cables for GPS and radio antenna connections and IRIG-B time distribution.



### USB Serial Cables

Add a 1.8 m (6 ft) or 4.6 m (15 ft) EIA-232 serial port cable to a PC USB port to communicate with SEL relays and other devices with EIA-232 serial ports.



### Electrical Data Cables

Apply SEL Electrical Data Cables to reliably connect SEL products and other devices, including relays, information processors, computers, I/O modules, meters, clocks, and modems.

Connector	SEL-C804	SEL-C805Z	SEL-C805D	SEL-C805G	SEL-C807Z	SEL-C807G	SEL-C808Z	SEL-C808P	SEL-C808G	SEL-C809Z	SEL-C809P	SEL-C809G
V-Pin	■	■	■	■								
ST	■	■	■	■	■	■	■	■	■	■	■	■
LC					■	■	■	■	■	■	■	■
SC							■	■	■	■	■	■

#### Fiber Diameter (Core/Outer)

1,000 μm	■											
200 μm		■	■	■								
62.5/200 μm					■	■						
62.5/125 μm							■	■	■			
9/125 μm										■	■	■

#### Wavelength

650 nm (Multimode)		■	■	■								
850 nm (Multimode)		■	■	■	■	■	■	■	■			
1,300 nm (Multimode)					■	■	■	■	■			
1,300–1,550 nm (Single-Mode)										■	■	■

#### Fiber Count

Simplex (1 Fiber)	■	■			■		■	■		■	■	
Duplex (2 Fibers)	■	■	■	■	■	■	■	■	■	■	■	■
Quad (4 Fibers)			■	■		■		■				

#### Cable Ratings

Riser-Rated (OFNR)		■	■		■		■	■	■		■	
Plenum-Rated (OFNP)							■				■	
Water-Blocked			■									
Waterproof				■		■		■				■

Jacket Material	SEL-C804	SEL-C805Z	SEL-C805D	SEL-C805G	SEL-C807Z	SEL-C807G	SEL-C808Z	SEL-C808P	SEL-C808G	SEL-C809Z	SEL-C809P	SEL-C809G
Polyvinyl Chloride (PVC)		■	■		■		■	■	■	■	■	■
Polyethylene (PE)	■			■		■						

#### Termination Kits

V-Pin Termination Kit	■	■	■	■								
ST Termination Kit	■	■	■	■	■	■						
LC, ST, and SC Termination Kit							■	■	■	■	■	■

#### Options

Bulk (No Connectors)	■	■	■	■	■	■	■	■	■	■	■	■
Pulling Loop			■	■		■			■			

#### Fiber-Optic Compatibility

SEL-2800/2810/2820		■	■	■								
SEL-2812/2814/2815/2824/3405/9220		■	■	■	■	■	■	■	■			
SEL-2829/2830/2831											■	■
SEL-751/751A/710-5 Arc-Flash Detection	■											
Multimode Fiber-Optic Ethernet					■	■	■	■	■			
Single-Mode Fiber-Optic Ethernet											■	■

■ Standard feature



# Remote I/O

[selinc.com/products/categories/measurement-streaming/#remote-i-o](http://selinc.com/products/categories/measurement-streaming/#remote-i-o)

Remote I/O modules transfer data from remote locations over fiber and expand the I/O of SEL relays, automation controllers, and other devices without modification to the control panel face.

## Applications

- Provide additional I/O for SEL protective relays and information processors
- Save wiring via I/O multiplexing
- Implement teleprotection
- Improve safety with optical fiber

## Case Study

Remote I/O Modules Enable DC Substation Transfer Trip for Expanding Denver Light Rail System

[selinc.com/api/download/2723](http://selinc.com/api/download/2723)

Number of I/O Channels	SEL-2440	SEL-2505	SEL-2506	SEL-2507	SEL-2515	SEL-2516	SEL-2595
Digital Inputs (DI) Base	32	8	8	8	8	8	8
DI Maximum	48	8	8	8	8	8	8
Digital Outputs (DO) Base	16	8	8		8	8	8
High-Speed DO Base	10			8			
DO Maximum	32	8	8	8	8	8	8

## Supported Protocols

SEL Fast Messaging					■	■	
SEL MIRRORING BITS Communications	■	■	■	■			
DNP3	+						
DNP3 LAN/WAN	+						
File Transfer Protocol (FTP)/Secure FTP (SFTP)	■						
IEC 61850 GOOSE	+						
IEC 61850 MMS	+						
IEEE C37.94							■
Modbus	■						
Parallel Redundancy Protocol (PRP)	■						
Precision Time Protocol (PTP)	■						
Simple Network Time Protocol (SNTP)	■						
Telnet	■						

■ Standard feature    + Model option



## SEL-2595 Teleprotection Terminal

Use the SEL-2595 to securely transfer teleprotection signals through a high-speed IEEE C37.94 optical-fiber interface.



## SEL-2505/2506/2507 Remote I/O Module

Connect a remote I/O module to a fiber-optic port or transceiver on a protective relay to add digital I/O. Or, wire the module I/O to relay I/O to add SEL MIRRORING BITS® teleprotection.



## SEL-2515/2516 Remote I/O Module

Connect these remote I/O modules, which are suitable for use in automation systems, to SEL information processors to easily expand inputs and outputs.



## SEL-2440 Discrete Programmable Automation Controller (DPAC)

The SEL-2440 offers utility-grade I/O, powerful processing, flexible communications, and microsecond timing.



# Annunciation and Notification

[selinc.com/products/categories/hmi-annunciators](http://selinc.com/products/categories/hmi-annunciators)

Annunciation and notification devices provide local and remote notification to improve situational awareness, efficiency, and safety. They display alarm conditions, and their communications ports enable integration with protection and automation systems.



## SEL-2522 Alarm Panel

Apply the SEL-2522 with up to 36 inputs to easily view the status of alarms and operating events.

	SEL-2522	SEL-2523	SEL-2533	SEL-2240
<b>Applications</b>				
Local Visual Indication	■	■	■	+
Remote Visual Indication		■	■	+
Local Audible Indication	■	■	■	
Remote Audible Indication	■	■	■	
Telephone Dial-Out Messages		■	■	
Local SELogic® Control Equations and Time Tagging		■	■	
IEC 61131 Logic Programming				■

## Mounting and Labeling

Rack Mount	+	+		■
Panel Mount	+	+	■	+
User-Defined Slide-In Labels	■	■	■	
Color LCD Software-Defined Labels				+

## Inputs, Outputs, HMI, and Protocols

Digital Inputs	36	42	14*	1,728
Acknowledge, Reset, and Test Digital Inputs	3	6	4*	
Digital Outputs	1	11	14*	864
Alarm Digital Output	1	1	1	1
General Display LEDs/Windows	36	36	10	625
Programmable LED				19
LCD Touchscreen				+
Pushbuttons	3	4	4	6
Base Serial Ports		1	1	4
Copper or Fiber-Optic Ethernet Ports				3
Optional Multimode Fiber-Optic Serial Port		1	1	
Optional Additional EIA-232 or EIA-485 Port		1	1	
IRIG-B Time Input		1	1	1
ISA Annunciation Alarm Sequence Choices	2	8	8	
Number of Supported Protocols		5	5	31

■ Standard feature    + Model option



## SEL-2523 Annunciator Panel

Provide local and remote notifications with the SEL-2523, which includes programmable logic and up to four communications ports.



## SEL-2533 Annunciator

Use the compact, ten-window SEL-2533 to provide local and remote annunciation.



## SEL-2240 Axion®

The Axion is a comprehensive control and monitoring solution that includes a full-color 7-inch touchscreen, allowing you to interact with up to 25 customizable alarm panels.



# Software

[selinc.com/products/categories/software](http://selinc.com/products/categories/software)

SEL software products help automate and control power systems, optimize device configuration, configure secure operational technology (OT) networks, and collect and visualize power system data.

SEL Compass® keeps software applications and relay configuration drivers up to date and includes SEL instruction manuals, application guides, hardware drivers, and more.

## Webinars

Streamline Data Collection and Fleet Management With DMA on Blueframe®

[selinc.com/events/on-demand-webinar/138573](http://selinc.com/events/on-demand-webinar/138573)

The Next Evolution in FLISR Simplicity: Automatic Configuration With GIS Data

[selinc.com/events/on-demand-webinar/138534](http://selinc.com/events/on-demand-webinar/138534)

Preventing PT Failures and Locating Generation Loss With Synchrowave® Operations

[selinc.com/events/on-demand-webinar/136575](http://selinc.com/events/on-demand-webinar/136575)

Improve Your Power System Visibility

[selinc.com/events/on-demand-webinar/140676](http://selinc.com/events/on-demand-webinar/140676)

Automate SDN Configuration With RTAC and IEC 61850 Files

[selinc.com/events/on-demand-webinar/137644](http://selinc.com/events/on-demand-webinar/137644)

Collect and Visualize Metering Data With Next-Generation Software

[selinc.com/events/on-demand-webinar/138791](http://selinc.com/events/on-demand-webinar/138791)

## Case Study

Real-Time Operational Use Cases for Time-Synchronized Measurements With Synchrowave Operations

[selinc.com/api/download/134864](http://selinc.com/api/download/134864)

Software Product	Configuration	Automation	Visualization and Analysis
ACSELERATOR QuickSet® SEL-5030 Software	■		
SEL Grid Configurator	■		
ACSELERATOR Architect® SEL-5032 Software	■		
ACSELERATOR RTAC® SEL-5033 Software	■		
ACSELERATOR Diagram Builder™ SEL-5035 Software	■		
ACSELERATOR® Bay Screen Builder SEL-5036 Software	■		
SEL-5051/5052 Client/Server Network Management System (NMS) Software	■	■	■
SEL-5056 Network Management System (NMS)	■	■	■
SEL-5057 SDN Application Suite—Flow Auditor			■
SEL Blueframe Device Management and Automation (DMA) Solution		■	
SEL Blueframe Distribution Management System (DMS) Solution		■	
SEL-5231 Configuration API	■		
SEL-5073 SYNCHROWAVE Phasor Data Concentrator (PDC) Software		■	
SEL-5601-2 Synchrowave Event Software			■
SEL-5702 Synchrowave Operations			■
SEL-5703 Synchrowave Monitoring			■
SEL-5705 Synchrowave Reports			■

<p><b>ACSELERATOR QuickSet</b> Included with supported products</p> <p>QuickSet is a tool to configure, commission, and manage devices for power system protection, control, metering, and monitoring.</p>	<p><b>SEL Grid Configurator</b> Included with supported products</p> <p>Grid Configurator makes it more efficient to configure and commission SEL power system devices using its spreadsheet-style editor, protection visualization, intuitive HMI, custom filters, and multiple-device settings management.</p>	<p><b>ACSELERATOR Architect</b> Included with supported products</p> <p>Architect streamlines the configuration and documentation of IEC 61850 messages, controls, and reports.</p>
<p><b>ACSELERATOR RTAC</b> Included with SEL RTAC purchase</p> <p>ACSELERATOR RTAC is an intuitive, easy-to-use application designed to configure the SEL Real-Time Automation Controller (RTAC) family of products, including the SEL-2240 Axion®.</p>	<p><b>ACSELERATOR Diagram Builder</b> Included with RTAC HMI purchase</p> <p>Diagram Builder enables the creation and management of HMI visualization projects for the SEL RTACs in your system.</p>	<p><b>ACSELERATOR Bay Screen Builder</b> Included with QuickSet and ACSELERATOR RTAC</p> <p>Bay Screen Builder, which works with QuickSet and ACSELERATOR RTAC, enables the custom creation of bay screens for SEL devices with touchscreen displays.</p>
<p><b>SDN Application Suite</b></p> <p>The SDN Application Suite includes Flow Auditor, which operates with SEL-5056 to provide safe, nondisruptive audits and documentation of conversations between hosts on your critical infrastructure network.</p>	<p><b>LAN Network Management System (NMS)</b> Included with SEL software-defined networking (SDN) switch purchase</p> <p>SEL-5056 NMS Software is the central controller for the configuration, monitoring, and management of SEL SDN-enabled switches.</p>	<p><b>WAN Client/Server NMS</b></p> <p>SEL-5051/5052 Client/Server NMS Software helps maintain a secure, reliable, and efficient communications infrastructure.</p>

**Example System Diagram**

Use SEL software solutions to optimize the configuration and management of SEL devices and networks, provide advanced automation and data collection capabilities, and offer robust tools for data visualization and analysis.

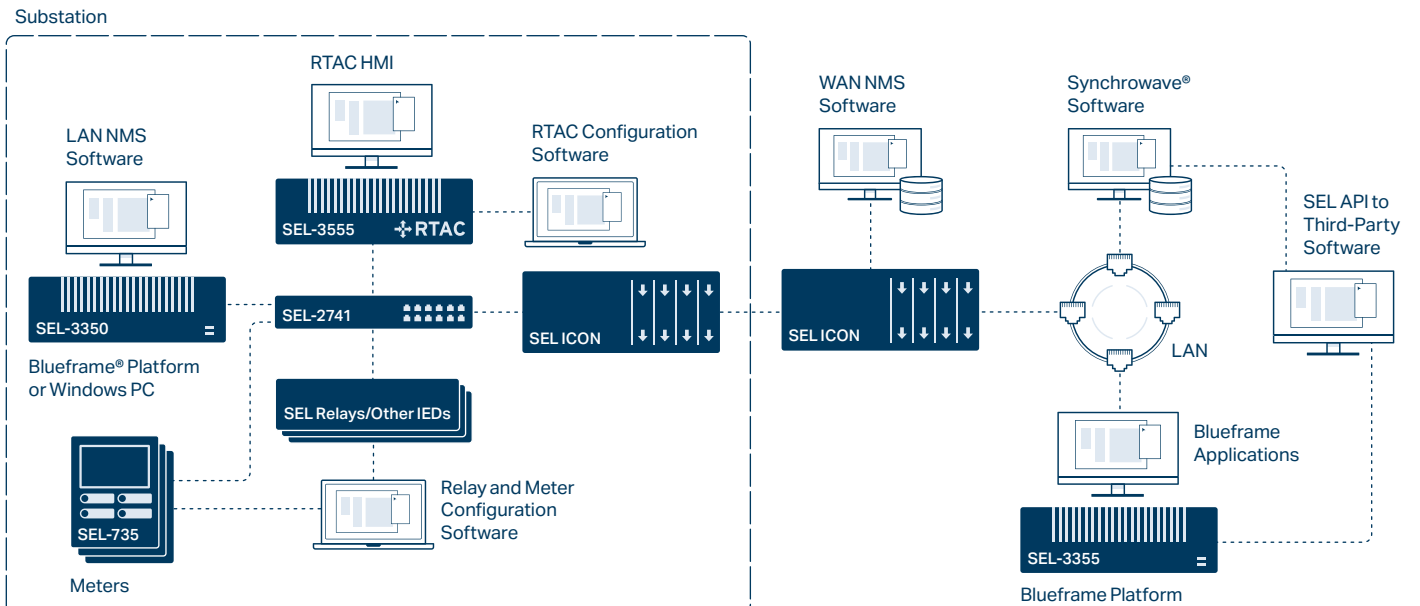

<p><b>SEL Blueframe Application Platform</b></p> <p>Blueframe is a secure application platform that can be deployed on an SEL computing platform or virtualized. It is purpose-built for managing large fleets of devices, visualizing and analyzing their data, and implementing automation and control solutions. SEL offers several power system solutions hosted on Blueframe.</p>	<p><b>SEL Device Management and Automation (DMA) Blueframe Application Suite</b></p> <p>The Blueframe DMA solution automatically collects, stores, and manages device specific information to simplify day-to-day management of a system of devices and to support compliance efforts.</p>	<p><b>SEL Distribution Management System (DMS) Blueframe Application Suite</b></p> <p>The Blueframe DMS solution includes a Fault Location, Isolation, and Service Restoration (FLISR) application package, which reduces customer outages, improves reliability metrics, and provides rapid fault detection and system restoration.</p>
<p><b>SEL Configuration API</b></p> <p>This API provides an integrated approach to managing SEL device configuration data, offering read/write access to device identification information, connection parameters, passwords, and settings stored in the ACSELERATOR Database.</p>	<p><b>Synchrowave Reports</b></p> <p>Synchrowave Reports simplifies metering and power quality data reporting by analyzing stored voltage sag, swell, and interruption (VSSI) and load profile (LDP) data, and automatically delivering scheduled reports by email.</p>	<p><b>Synchrowave Event</b></p> <p>Synchrowave Event provides a platform to display and analyze recorded power system data from SEL relay event records, motor start reports, synchrophasor data, COMTRADE files, and more.</p>
<p><b>Synchrowave Operations</b></p> <p>Synchrowave Operations increases grid safety and reliability through situational awareness with high-resolution time-series data, real-time analytics, and geographical information system (GIS) location information.</p>	<p><b>Synchrowave Monitoring</b></p> <p>Synchrowave Monitoring brings synchrophasor data, streaming waveform data, and relay event reports together into one place so engineers can analyze both the high-level system impact of an event and the detailed oscillography data.</p>	<p><b>SEL RTAC HMI</b></p> <p>The SEL RTAC HMI offers an easy way to visualize data to monitor and control your system.</p>
<p><b>SYNCHROWAVE PDC</b></p> <p>SYNCHROWAVE PDC provides synchrophasor aggregation and time alignment for downstream applications and inter-entity data sharing.</p>		



# Accessories and Tools

[selinc.com/products/categories/cables-accessories](http://selinc.com/products/categories/cables-accessories)



## SEL-3790 Low-Voltage Divider Module **NEW**

Apply the compact, lightweight SEL-3790 as a low-power voltage transformer in switchgear and other space-limited applications. This module takes in voltages between 120 Vac and 480 Vac and produces a voltage suitable for SEL relays with low-power inputs.

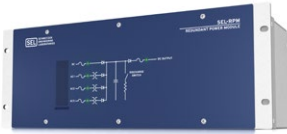

## SEL-RPM Redundant Power Module

Use the SEL-RPM to combine as many as three ac sources and one dc source to provide a single reliable dc output (unregulated 125 Vdc). Large energy storage capacitors provide ride-through capability when all input sources are lost.



## SEL-9321 Low-Voltage DC Power Supply or SEL-9322 15 Vdc Power Supply

Provide low-voltage dc power from station battery or ac sources for communications devices and accessories with SEL-9321 and SEL-9322 power supplies.



## SEL-9501 or SEL-9502 Contact Arc Suppressor

Decrease maintenance costs, increase contact reliability, and reduce destructive dc circuit overvoltages with the self-powered SEL-9501/9502 arc suppressors.



## SEL-4520 Arc-Flash Test Module

Use the SEL-4520 to conveniently test the operation of arc-flash detection relays installed in metal-clad and metal-enclosed switchgear.



## SEL-4388 MIRRORRED BITS® Tester

Accelerate commissioning and bench testing of SEL MIRRORRED BITS links and improve training, maintenance, and cable identification with the SEL-4388.



## SEL-9510 Control Switch Module

Use the SEL-9510 where independent local control is needed. High-visibility status indication and arc-suppressed contacts are ideal for breaker control.



## SEL-2126 Fiber-Optic Transfer Switch

Apply the SEL-2126 to simply reroute any communications protocol carried on the IEEE C37.94 fiber-optic interface standard without moving fiber connectors and without changing communications equipment programming.



## SEL-2652 Trip Coil Monitor

Verify circuit breaker or lockout relay trip coil and trip circuit continuity with the SEL-2652.



# Panels and Enclosures

[selinc.com/services/panels-enclosures](http://selinc.com/services/panels-enclosures)

SEL designs, manufactures, tests, and delivers custom protection, control, and metering panels, control cabinets, retrofit doors, and enclosures. We integrate multiple pieces of equipment (from SEL and other manufacturers) into a single assembly or kit, enabling one-stop shopping for assemblies and labor with a quick turnaround time. Our experts will work with you to understand your requirements and challenges and provide innovative, economical solutions built to the highest quality standard.

## Customer Stories

Partnership and Panels Improve Infrastructure

[selinc.com/highlights/rayburn-electric](http://selinc.com/highlights/rayburn-electric)

Distribution Modernization in Kentucky

[selinc.com/highlights/lge-ku](http://selinc.com/highlights/lge-ku)



## Complete Panel and Enclosure Solutions

SEL custom panel and enclosure solutions come with the following options and services:

- Consulting, engineering design, and field services.
- Panel and assembly manufacturing tested in our in-house UL 508A-certified panel factories.
- Protection, automation, and control equipment manufacturing.
- Easily extractable assemblies for all SEL-700 and SEL-2400 series products.
- Cabinet designs for both indoor and outdoor applications, including stainless steel, mild steel, aluminum, fiberglass, and polycarbonate enclosures.
- Enclosures, racks, bezels, plates, portables, swing panels, doors, and retrofits.
- Assemblies that meet Seismic, NEMA, and UL 508A rating and certification requirements.



## Complete Design, Manufacturing, Testing, and Commissioning

To exactly meet your needs, we offer complete panel and enclosure solutions, from design through commissioning. We test the final implementation of every product or system before it ships, reducing your overall project costs and engineering time. This testing makes commissioning easier and faster.

## Field Services

SEL provides complete installation services during any project phase, from demolition and wiring to testing and commissioning. SEL teams have extensive safety training and provide the same level of quality customers have come to expect from SEL manufacturing and other services.

Available field services include:

- Site investigation and surveying.
- Demolition and site development.
- Construction management.
- New relay panel installation, integration, and wiring.
- Automation and control system installation.
- SCADA installation.
- Arc-flash solutions.
- Testing and commissioning.
- Life cycle support.



# Direct-Replacement Assemblies

[selinc.com/products/categories/panels-enclosures/#direct-replacements-retrofits](http://selinc.com/products/categories/panels-enclosures/#direct-replacements-retrofits)

Streamline retrofit projects with SEL direct-replacement assemblies for motor, generator, transformer, bus, feeder, and metering applications. These complete, factory-tested, preassembled retrofit kits are designed to closely match the features, form-factor, and terminal blocks of specific legacy digital and electromechanical relays. Direct-replacement assemblies combine field-proven SEL relays with specialized mounting plates, interposing terminal blocks, and other hardware to ensure quick, seamless, and cost-effective upgrades.



## Simplify Installation and Configuration

Direct-replacement assemblies deliver an installation experience that is easy, fast, and error-free. The physical installation work for most digital direct-replacement assemblies can typically be completed within an hour. Assemblies fit the existing panel opening and mounting holes. Terminal block arrangements and wiring designations closely match legacy products, and SEL provides wiring labels with all retrofit kits.

Electromechanical direct-replacement assemblies are designed to replace sets of three or four electromechanical relays aligned horizontally on the same panel with a digital relay and test switch(es). Installation can typically be completed within just a few hours with the removal of the panel dividers between the old relays and the addition of power supply connections.



## Minimize Engineering Work

Eliminate time-intensive and costly engineering tasks, such as revising drawings and diagrams. All assembly kits include wiring diagrams, so existing documentation for your system is not required for installation.

## Partner With SEL on a Turnkey Solution

We offer complete design, installation, and commissioning services for retrofit projects, saving you time and reducing costs.

Manufacturers we offer direct-replacement assemblies for include:

- GE
- Westinghouse
- Cutler-Hammer
- Eaton
- Square D
- ABB
- Siemens
- Schneider Electric



# SEL Services

selinc.com/services | esinfo@selinc.com

SEL Engineering Services engineers and staff approach every project with a spirit of quality, innovation, and service. We offer a broad range of expertise and support to the utility, industrial, commercial, and governmental sectors. From planning and implementation through ongoing maintenance and support, we deliver a solution tailored to your needs.



## Featured Services and Solutions

### Transmission, Distribution, and Substation Engineering

From design through construction, our multidisciplinary SEL Engineering Services teams help ensure the cost effectiveness, quality, and overall success of your transmission, distribution, or substation project. We provide development, modernization, and maintenance solutions to ensure your power systems are safe, reliable, and economical.

### Protection and Control

SEL Engineering Services optimizes your power system protection and control. We specify, design, implement, test, and commission power solutions. Our solutions safeguard valuable equipment, mitigate cyber threats, minimize outages, and meet safety and security compliance standards.

### Microgrids and Power Management

SEL Engineering Services engineers are experts at designing microgrid control systems and power management solutions for all your project needs. Our solutions include comprehensive generation and load management using relays, logic, and control systems. See page 72 for more information.

### Field Services

Whether you're upgrading, expanding, or implementing an entirely new system, SEL Engineering Services technicians can handle all phases of your project—from surveying, demolition, and wiring to installing, testing, and commissioning.

### System Studies and Modeling

SEL Engineering Services uses a wide array of power system analysis tools, such as phasor domain modeling and electromagnetic transients program modeling, to perform non-real-time analysis and real-time hardware-in-the-loop studies to simulate "what if" scenarios.

### Cyber Services

SEL Cyber Services designs end-to-end operational technology (OT) security solutions to uniquely support your needs. Our full suite of security services strengthens your defenses, streamlines maintenance, and helps ensure compliance. See page 73 for more information.

### Panels and Enclosures

SEL designs, manufactures, tests, and delivers custom protection, automation, control, and metering panels, control cabinets, and retrofit doors. SEL also helps you streamline your retrofit projects with direct-replacement assemblies that cause minimal impact on panels, wiring, and drawing sets.

### Project and Program Management

As your complete substation solutions partner, SEL offers a single point of accountability—one trusted partner from concept to completion. Our comprehensive approach includes system and site planning, civil and structural engineering, equipment procurement, contractor management, testing, and commissioning. See page 71 for more information.

### Government Services

SEL provides infrastructure protection, monitoring, and control systems to United States government agencies and their contractors—supporting mission-critical applications where reliability, cybersecurity, and supply chain assurance are essential.



# Project and Program Management

[selinc.com/services/project-program-management](http://selinc.com/services/project-program-management)

SEL provides solutions for substation engineering capital projects, programmatic equipment replacement, and unscheduled maintenance equipment replacement or upgrades. We ensure that power system solutions meet both industry standards and your own project-specific requirements.

## Engineering

We provide electrical, civil, and structural engineering services for substation projects of any size and voltage, from targeted upgrades and retrofits to electrical and civil design packages for complete substations.

## Procurement

We can partner with your preferred suppliers or bring on our team of prequalified subcontractors. We assist with procuring turnkey components and work closely with you to maximize value by reducing lifecycle costs.

## Construction Management

As your construction management partner, SEL ensures the successful execution and completion of the project with an unwavering commitment to safety and quality.

We also provide planning, program management, project management, owner's engineering, and staff augmentation services as part of a master services agreement, engineer-of-choice designation, or individual contract.

## Planning

SEL Engineering Services discusses with you the feasibility and broad goals of your program or project. We advise which projects to pursue, in what order, and help you determine which emerging technologies apply to your current and future needs.

## Owner's Engineering

Put our deep technical knowledge and industry expertise to work for you with SEL owner's engineering services. As an owner's engineer, we will work in your interests to help maximize safety, reliability, and profitability, both short- and long-term, for your project or program.

## Program Management

SEL Engineering Services program management supports your large initiatives to help you align project goals and allocate resources. As projects progress, our program managers help coordinate the different components of the program to meet deadlines and budgets.



## Customer Story

Distribution Modernization in Kentucky

[selinc.com/highlights/lge-ku](http://selinc.com/highlights/lge-ku)



# Microgrids and Power Management

[selinc.com/services/microgrids-power-management](http://selinc.com/services/microgrids-power-management)

SEL Engineering Services personnel are experts at designing solutions for a variety of applications, including industrial power management systems, microgrid control systems (MCSs), remedial action schemes (RASs), and wide-area monitoring, protection, and control (WAMPAC).

## Industrial Power Management

POWERMAX® Power Management and Control Systems intelligently balance generation and load at subcycle speeds to maintain grid stability, help mitigate widespread outages, reduce operating expenses, and meet everchanging system demands.

POWERMAX is a scalable, fast, and secure system composed of relay and control hardware, software, and logic processing, all designed by our expert power engineers. Benefits include:

- Advanced high-speed protection and control technology—such as islanding detection and decoupling, high-speed load shedding, generation shedding, and generator runback—to keep your critical processes running.
- Total system awareness with time-synchronized condition monitoring that tracks equipment status, electrical metering, cyber attacks, network traffic, and more.
- Point of common coupling management with power factor control, power export and import management, and single-click synchronization.
- Improved human safety and reduced equipment damage with adaptive protection, advanced protection systems, and arc-flash mitigation.

## Microgrid Control Solutions

Microgrids enhance energy reliability, resilience, and sustainability. They operate with the grid or islanded, integrating distributed energy resources for local power generation, energy storage, grid independence, and cost savings.

We apply our POWERMAX control logic to your microgrid to create a system that seamlessly meets your control, protection, and monitoring requirements. Our power system engineers work closely with microgrid owners and integrators to design, engineer, and implement the optimal MCS for your operational requirements.

## Remedial Action Schemes

SEL POWERMAX provides the foundation for an RAS to integrate large geographic regions of interconnected generation sources, transmission lines, and loads. We incorporate a POWERMAX RAS with your existing relays, meters, and communications systems to reduce overall project costs.

Key applications for a POWERMAX RAS include:

- The addition of large renewable sources, such as wind power stations and photovoltaic arrays, with transmission systems.
- High-speed generation and/or load shedding to maintain grid stability.
- Synchrophasor monitoring and control.
- Fast decoupling solutions.
- Distributed computing and communications for smart transmission grid management.



## WAMPAC Systems

WAMPAC systems allow operators to achieve comprehensive situational awareness over large geographical areas. WAMPAC and POWERMAX complement each other to provide visualization, analysis, notification, and archiving of time-series data, including synchrophasor data, relay event reports, point-on-wave data, and geographic information system (GIS) geospatial data. WAMPAC informs or triggers coordinated responses to correct system issues and maintain grid reliability.

## Customer Stories

Microgrid Solution Plays Big on Campus  
[selinc.com/highlights/msu](http://selinc.com/highlights/msu)

Innovation, Persistence, and a New Beginning  
[selinc.com/highlights/gse-short](http://selinc.com/highlights/gse-short)

POWERMAX Prevents Blackouts at Motor Oil Hellas Refinery  
[selinc.com/highlights/motor-oil-hellas](http://selinc.com/highlights/motor-oil-hellas)



# Cyber Services

[selinc.com/services/cyber-services](http://selinc.com/services/cyber-services)

No matter your stage of the cyber lifecycle, our Cyber Services engineers build OT security solutions that are secure down to their very architecture. We use a front-end engineering methodology to design systems that uniquely support both your mission and your operational needs. From system assessment and baselining to cyber-defense solution development and ongoing system management, our full suite of security services strengthens your defenses, streamlines maintenance, and helps ensure compliance.

## Assessments, Governance, and Compliance

We provide services and solutions that streamline the demanding, potentially time-consuming tasks of maintaining compliance and keeping your infrastructure secure. We assist in determining high-value assets and threat vectors to identify next steps and solutions while helping define procedures and draft documentation to assist with system and process audits.

## Security Resilience and Design

We ensure network resilience and security through a secure-by-default approach to system design. Integrating layered defenses, secure networking, and robust perimeter protection safeguards the integrity and availability of critical infrastructure. This forms a resilient, defense-in-depth architecture to defend against evolving threats. With remote access solutions and SEL security professionals augmenting your staff, you gain both the flexibility and the expertise to intelligently manage and protect your systems.

## Monitoring and Detection

Accredited cybersecurity engineers help you understand regulatory standards for internal network security monitoring (INSM) and assess your existing system. We collaborate with world-class cybersecurity vendors to leverage the best tools available and deliver an INSM solution that leverages any compatible devices you already own.

## Life Cycle Support

We offer readiness and response for cyber incidents, monitoring, and maintenance.

- **Readiness and Response**  
We deliver proactive services, such as penetration testing, cybersecurity maturity assessments, employee training, and architecture reviews, to strengthen your security posture.
- **Maintenance**  
We provide ongoing support through patch, firmware, and software update management; security alert reviews; and alignment with future project needs.
- **Monitoring**  
We monitor SEL-designed or third-party-installed networks for threats and suspicious activity to ensure continuous situational awareness.

## Cybersecurity Center

Our ICS and OT Cybersecurity Center provides the latest SEL industrial control system (ICS) and OT updates and a space to communicate with experts, analyze challenges, and share ideas.



## Customer Stories

Defending Critical Substation Communications in Slovenia  
[selinc.com/highlights/eles](http://selinc.com/highlights/eles)

Remote Engineering Access Solution Delivers Cybersecurity and Convenience  
[selinc.com/highlights/gvea](http://selinc.com/highlights/gvea)



# Education and Training

[selinc.com/education](http://selinc.com/education)

## Online Technical Resources

Get access to secure product information, configure and order products, and register for trainings with an SEL account. Visit [selinc.com](http://selinc.com) and select "Login" at the top right corner of your screen. You'll be able to:

- Access secure product information, like application guides and instruction manuals.
- Watch recorded webinars.
- View on-demand virtual presentations.
- Register for seminars, SEL University courses, and other educational offerings.



## Schweitzer Drive Podcast

Our "Schweitzer Drive" podcast explores what goes on between the generation of electricity and the light switch. In each episode, SEL President Dave Whitehead talks with the entrepreneurs, innovators, and experts who are inventing the future of electric power. Visit [selinc.com/schweitzerdrive](http://selinc.com/schweitzerdrive) to listen.

## SEL University

Learn about power system fundamentals, the physics of power system protection, and advanced product applications with courses from SEL University. Gain Professional Development Hours (PDHs) and the confidence to install and commission SEL protection, automation, cybersecurity, and control products. Our training formats include eLearning courses as well as in-person and virtual courses that are taught by the same engineers who design SEL equipment and solutions, support customers, and author industry publications. Our power system experts have trained tens of thousands of industry professionals worldwide to help them meet the technical challenges of integrating digital technologies into their expanding power system infrastructure.

SEL University covers topics such as:

- Introduction to SEL relays.
- Cybersecurity and securing operational technologies (OT) networks.
- SEL Real-Time Automation Controller (RTAC) applications.
- Protecting power systems for engineers.

See available courses and register at [selinc.com/selu](http://selinc.com/selu).

## Technical Papers, Webinars, and Videos

SEL power system experts have authored more than 1,000 technical papers, hosted hundreds of webinars, and developed dozens of support videos. They are dedicated to teaching about how our technologies solve complex power system challenges and about how we partner with our customers to solve tough problems. Visit [selinc.com](http://selinc.com) to access our library of educational material, including these trending and top five downloaded technical papers:

## Trending Technical Papers

Beyond the Nameplate: Transformer Compensation Revisited—New Applications, Greater Simplicity  
[selinc.com/api/download/138123](http://selinc.com/api/download/138123)

Zero-Setting Broken Conductor Detection Method Using Local Measurements Only  
[selinc.com/api/download/138742](http://selinc.com/api/download/138742)

Solving Complex Feeder Protection Challenges and Reducing Wildfire Risks With Remote Measurements  
[selinc.com/api/download/138149](http://selinc.com/api/download/138149)

Case Study: Implementing a Zero-Touch Deployment Methodology Using SDN to Improve the Security, Reliability, and Engineering of Substation Automation Systems in Slovenia  
[selinc.com/api/download/138803](http://selinc.com/api/download/138803)

Case Study: A Subtransmission-Level Fault Location, Isolation, and Service Restoration (FLISR) Scheme  
[selinc.com/api/download/140447](http://selinc.com/api/download/140447)

## Top Five Downloaded Technical Papers of 2025

Introduction to Symmetrical Components  
[selinc.com/api/download/2470](http://selinc.com/api/download/2470)

Review of Ground Fault Protection Methods for Grounded, Ungrounded, and Compensated Distribution Systems  
[selinc.com/api/download/2604](http://selinc.com/api/download/2604)

Current Transformer Accuracy Ratings  
[selinc.com/api/download/3684](http://selinc.com/api/download/3684)

Considerations for Using High-Impedance or Low-Impedance Relays for Bus Differential Protection  
[selinc.com/api/download/5562](http://selinc.com/api/download/5562)

Understanding Generator Stator Ground Faults and Their Protection Schemes  
[selinc.com/api/download/111667](http://selinc.com/api/download/111667)

## Bookstore

Visit the SEL bookstore at [selinc.com/bookstore](http://selinc.com/bookstore) for textbooks and focused technical paper anthologies, like the following:

- Modern Solutions for Protection, Control, and Monitoring of Electric Power Systems
- Synchronous Generator Protection and Control
- Line Current Differential Protection
- Locating Faults and Protecting Lines at the Speed of Light

*Modern Solutions for Protection, Control, and Monitoring of Electric Power Systems* offers a comprehensive reflection of technologies developed by SEL engineers and spans topics of interest to people working in protection, control, communications, regulation, education, and design.

Online you'll also find these books written by Stanley E. Zocholl, an SEL Distinguished Engineer and IEEE Life Fellow:

- Analyzing and Applying Current Transformers
- AC Motor Protection

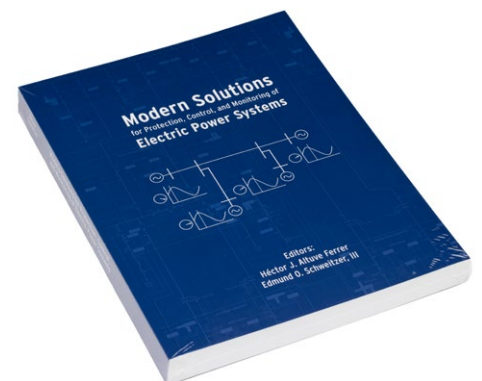



# Ordering and Customer Support

[selinc.com/support](http://selinc.com/support) | +1.509.338.3838

## Online Configuration and Ordering

Configure products to meet your exact application needs and order them online with an SEL account. Once logged in, select “Configure and Order” on a product webpage to choose from available model options, including items like power supply voltages, inputs and outputs, communications ports and protocols, and conformal coating. Save individual products to your cart, create projects to house specific product orders, and request a quote—all online. For products that do not require configuration or have been identified as common product configurations, select “Popular Models” on a product webpage to quickly and easily find the model you want.

## Ordering Support

Our sales representatives and customer service teams are always happy to answer questions and help configure the right SEL solution for your application. Visit [selinc.com/support](http://selinc.com/support) for regional sales contact information.

## Popular Models

The Popular Models program makes selecting and ordering SEL products simple, fast, and convenient. SEL popular models are products preconfigured for popular applications and available for many SEL devices. Specific popular models may ship from stock. When available, the popular model configurations are displayed on the related SEL product webpage, where you can also view their technical details and popular applications. You can order these models directly from SEL or through your SEL sales representative.

## Local Support. Global Expertise.

Whether it’s grid modernization in the Philippines or an ambitious offshore wind integration project in Belgium, our global engineering experts have helped projects in regions like yours succeed. And with local support from technical staff in your region, you can count on us to help your successes continue.

Scan to find a customer support representative in your area.

[selinc.com/support](http://selinc.com/support)

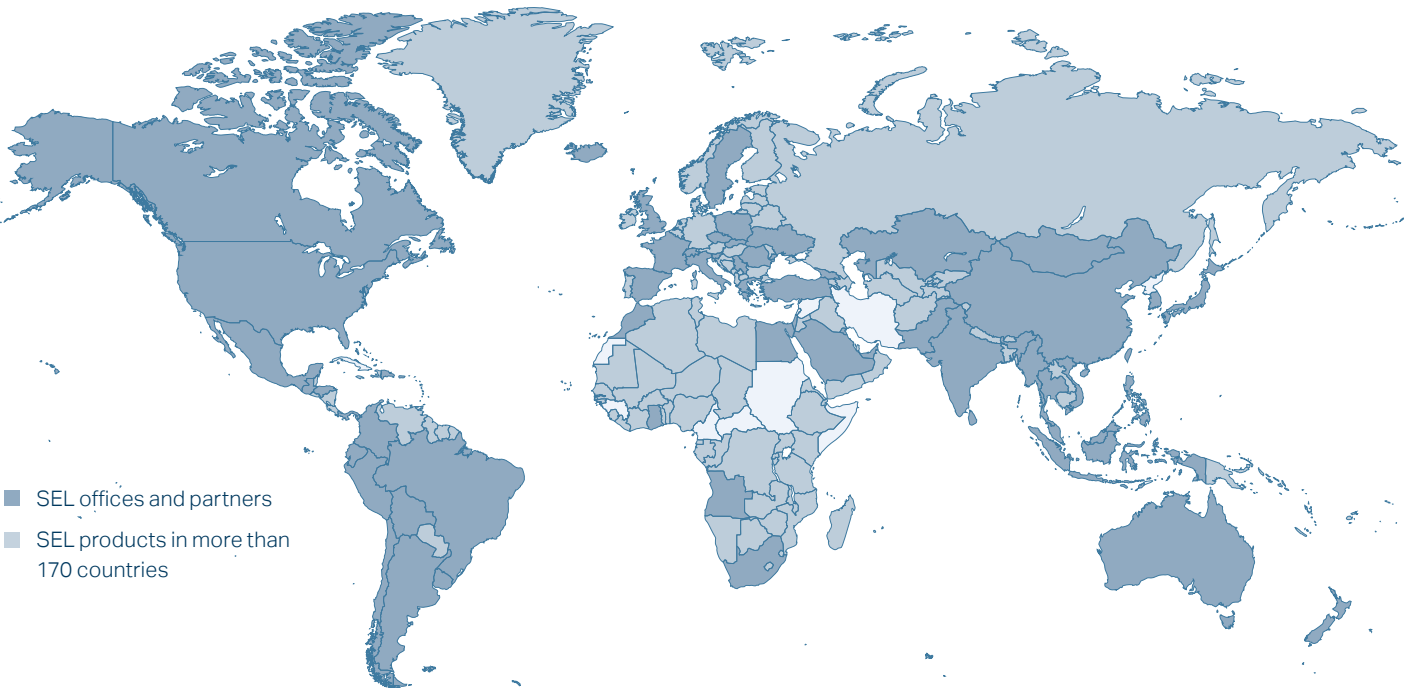





# Index

9L Line Relay <b>COMING SOON</b>	17	849 Motor Management Relay	13	2810 Fiber-Optic Transceiver With IRIG-B	59
300G Generator Relay	10	851 Feeder Protection Relay	13,30	2812 Fiber-Optic Transceiver With IRIG-B	59
311C Transmission Protection System	17	2126 Fiber-Optic Transfer Switch	67	2814 Fiber-Optic Transceiver With Hardware Flow Control	59
311L Line Current Differential Protection and Automation System	17	2240 Axion®	44,63	2815 Fiber-Optic Transceiver/Modem	59
351 Protection System	30	2401 Satellite-Synchronized Clock	56	2820 Multimode Fiber-Optic EIA-485 Transceiver	59
351A Protection System	30	2407® Satellite-Synchronized Clock	56	2824 Multimode Fiber-Optic EIA-485 Transceiver	59
351RS Kestrel® Single-Phase Recloser Control	32	2411 Programmable Automation Controller	44	2829 Single-Mode Fiber-Optic Transceiver/Modem	59
351S Protection System	30	2411P Pump Automation Controller	44	2830 Single-Mode Fiber-Optic Transceiver/Modem	59
352 Breaker Failure Relay	24	2414 Transformer Automation Controller <b>NEW</b>	10,24,44	2831 Single-Mode Fiber-Optic Transceiver/Modem	59
400G Advanced Generator Protection System	10	2431 Voltage Regulator Control	32	2886 EIA-232 to EIA-485 Interface Converter	59
401 Protection, Automation, and Control Merging Unit	24	2440 Discrete Programmable Automation Controller (DPAC)	44,62	2890 Ethernet Transceiver	59
411L Advanced Line Differential Protection, Automation, and Control System	17	2488 Satellite-Synchronized Network Clock	56	2894 Interface Converter	59
421 Protection, Automation, and Control System	17	2505 Remote I/O Module	62	2902 RJ45 to DB-9 Adapter Panel	59
451 Protection, Automation, and Bay Control System	30	2506 Rack-Mount Remote I/O Module	62	3031 Serial Radio Transceiver	55
487B Bus Differential and Breaker Failure Relay	24	2507 High-Speed Remote I/O Module	62	3061 Cellular Router	54
487E Transformer Protection Relay	24	2515 Remote I/O Module	62	3350 Computing Platform	14,43
487V Capacitor Protection and Control System	24	2516 Rack-Mount Remote I/O Module	62	3355 Computing Platform	43
651R Advanced Recloser Control	32	2522 Alarm Panel	63	3360S Compact Computing Platform	43
651RA Recloser Control	32	2523 Annunciator Panel	63	3360E Compact Computing Platform	43
700BT Motor Bus Transfer Relay	13	2533 Annunciator	63	3400 IRIG-B Distribution Module	56
700G Generator Protection Relay	10,14	2595 Teleprotection Terminal	62	3401 Digital Clock	56
710-5 Motor Protection Relay	13	2600 RTD Module	10,14	3405 High-Accuracy IRIG-B Fiber-Optic Transceiver	56
734B Advanced Monitoring and Control System	32	2652 Trip Coil Monitor	67	3505 Real-Time Automation Controller (RTAC)	43
734W Capacitor Bank Control	32	2664 Field Ground Module	10	3505-3 RTAC	43
735 Power Quality and Revenue Meter	14,39	2664S Stator Ground Protection Relay	10	3555 RTAC	10,14,43
751 Feeder Protection Relay	13,30	2725 Five-Port Ethernet Switch	52	3560E RTAC	43
787-2/-3/-4 Transformer Protection Relay	14,24	2731 Ethernet Switch	52	3560S RTAC	43
787L Line Current Differential Relay	13	2740S Software-Defined Network Switch	52	3620 Ethernet Security Gateway	52
787Z High-Impedance Differential Relay and SEL-HZM High-Impedance Module	14,24	2741 Ethernet Switch	52	3622 Security Gateway	52
		2742 Ethernet Switch	10,14,52	3780 Test Point Voltage Sensor	37
		2743 Ethernet Switch <b>NEW</b>	52	3790 Low-Voltage Divider Module <b>NEW</b>	67
		2744 Ethernet Switch <b>NEW</b>	52		
		2800 Fiber-Optic Transceiver	59		

4388 MIRRORING BITS® Tester	67	C805 200 µm Multimode Fiber-Optic Cable	60	Synchrowave® Software	39,41
4520 Arc-Flash Test Module	67	C807 62.5/200 µm Multimode Fiber-Optic Cable	60	T35 Time-Domain Power Monitor <b>NEW</b>	41
5030 ACSELERATOR QuickSet® Software	65	C808 62.5/125 µm Multimode Fiber-Optic Cable	60	T401L Ultra-High-Speed Line Relay	17
5032 ACSELERATOR Architect® Software	65	C809 9 µm Single-Mode Fiber-Optic Cables	60	T4287 Traveling-Wave Test System	17
5033 ACSELERATOR RTAC® Software	44,65	Cables—Coaxial, Electrical Data, Ethernet, and USB	60	TMU TiDL® Merging Unit	24
5035 ACSELERATOR Diagram Builder™ Software	44,65	CRD Overhead Current Reset Fault Indicator	36	TPR Underground Test Point Reset Fault Indicator	37
5036 ACSELERATOR® Bay Screen Builder Software	44,65	CT Split-Core Current Transformers	37	TWFL Dual Traveling-Wave Fault Locator and 12-Channel MHz Recorder	17
5037 Grid Configurator Software	65	Direct-Replacement Assemblies	69	Wireless Protection System	30,36
5051/5052 Client/Server Network Management System (NMS) Software	65	ER Overhead Electrostatic Reset Fault Indicator	36		
5056 Network Management System (NMS) Software	65	FLR Fault and Load Receiver	36		
5057 SDN Application Suite	65	FLT Fault and Load Transmitter	36		
5073 SYNCHROWAVE® PDC Software	66	FR12 Fault Receiver	30		
5231 SEL Configuration API	66	FT50 Fault Transmitter	30		
5601-2 Synchrowave® Event Software	66	ICON® Integrated Communications Optical Network	52,56		
5705 Synchrowave® Reports	66	LINAM® UGFI Underground Fault Indicator <b>NEW</b>	37		
9220 Fiber-Optic Adapter for SEL-300 Series Relays	59	LINAM® WCS Wireless Current Sensor	32		
9321 Low-Voltage DC Power Supply	67	MR Manual Reset Fault Indicator	36		
9322 15 VDC Power Supply	67	Panels and Enclosures	68		
9501 Contact Arc Suppressor	67	PILC Underground Paper-Insulated Lead-Covered Cable Fault Indicator	37		
9502 Contact Arc Suppressor	67	RadioRANGER® Underground Wireless Fault Indication System	37		
9510 Control Switch Module	67	RP50 Fault Repeater	30		
9524 GNSS Antenna	56	RPM Redundant Power Module	67		
9929 Satellite-Synchronized Clock Display Kit	56	RTAC HMI	66		
AR Overhead AutoRANGER Fault Indicators	36	Services—Complete Design, Manufacturing, Testing, and Commissioning	68		
AR360 Overhead AutoRANGER Fault Indicators	36	Services—Cyber Services	73		
Blueframe® Application Platform	44,66	Services—Microgrids and Power Management	72		
Blueframe® Device Management and Automation (DMA) Application Suite	44,66	Services—Project and Program Management	71		
Blueframe® Distribution Management System (DMS) Application Suite	44,66				
C804 Multimode Arc-Flash Detection Fiber-Optic Cable	60				

The information in this document is furnished for informational use only and is subject to change without notice. Drawings are for illustrative purposes only; they are not for construction. Schweitzer Engineering Laboratories, Inc., is also referred to in this catalog as Schweitzer Engineering Laboratories. All brand or product names appearing in this document are the trademark or registered trademark of their respective holders in the U.S. and other countries. No SEL trademarks may be used without written permission. SEL products appearing in this document may be covered by U.S. and Foreign patents.

EtherCAT® is a registered trademark and patented technology, licensed by Beckhoff Automation GmbH, Germany.

© 2025 by Schweitzer Engineering Laboratories, Inc. All rights reserved.



2350 NE Hopkins Court, Pullman, WA 99163 USA

+1.509.332.1890

[info@selinc.com](mailto:info@selinc.com)

[selinc.com](http://selinc.com)