

EHV Reactor Protection: A Utility's Perspective

Steve Mueller

Ameren

Michael Thompson

Schweitzer Engineering Laboratories, Inc.

Revised edition released April 2026

Previously presented at the
78th Annual Georgia Tech Protective Relaying Conference, May 2025
and 52nd Annual Western Protective Relay Conference, October 2025

Previously revised editions released April 2025 and October 2025

Originally presented at the
78th Annual Conference for Protective Relay Engineers at Texas A&M, April 2025

EHV Reactor Protection: A Utility's Perspective

Steve Mueller, *Ameren*

Michael Thompson, *Schweitzer Engineering Laboratories, Inc.*

Abstract—Shunt reactors on extra-high-voltage (EHV) lines and buses are becoming more common. The grid is changing with investment in long lines to bring remote, renewable resources to load centers. Utility-scale generating facilities made up of inverter-based resources are displacing conventional generation and often have little ability to absorb reactive power.

Coincident with the need to install more shunt reactors on the system, reactor protection practices have evolved with new technology and new ideas. IEEE C37.109-2023, IEEE Guide for the Protection of Shunt Reactors represents a significant update over the previous version published in 2006. As is characteristic of an IEEE guide, it presents many generally accepted practices and it is up to the user to select those that best fit within their practical requirements and general philosophies.

Ameren has updated their protection standards to take advantage of the best ideas from the new guide. This paper describes Ameren's new reactor protection standard and the perspectives that defined the design. Readers can use this paper as a practical reference for navigating the new 93-page guide.

I. INTRODUCTION

Shunt reactors help control voltage on the transmission grid by absorbing excess capacitive reactive power from the natural capacitance between phases and between phases and ground of transmission lines. During light loading conditions where I^2X reactive power losses in the inductive transmission system are small, this excess capacitive reactive power can cause voltage to rise above design limits. The problem has historically been associated with very long lines and very high voltages but is becoming more common due to changes in the bulk electric system.

Shunt reactors are typically installed on transmission line terminals and buses or on medium-voltage transformer tertiary buses. This paper focuses on Ameren's updated protection practices applied to solidly grounded, transmission-connected shunt reactors. Ameren specifies liquid-immersed, gapped iron-core reactors for these installations. Fig. 1 shows one installation. While the focus of the paper is on this type of reactor, we cover protection differences for extra-high-voltage (EHV) dry-type, air-core reactors as well.

For many years, Ameren had very little need for reactive power compensation in their midwestern transmission footprint. Long transmission lines were rare and conventional generating plants that could control voltage by absorbing excess reactive power during light load conditions were located throughout the system. The generation and load density, while not high compared to densely urbanized areas of the country, could not be considered sparse either.

The grid has been changing since those times. There is strong investment in renewable energy resources and the associated lines to interconnect them with the bulk electric

system. Often these facilities are distant from load, requiring the interconnecting lines to be long. The majority of these facilities are wind and solar. These inverter-based resources often have little capacity to absorb reactive power, raising the importance of shunt reactors.



Fig. 1 Ameren 345 kV liquid-immersed gapped iron-core reactor.

Ameren is proactively installing EHV shunt reactors as needed to support the transition from fossil fuel generation to inverter-based resources. To prepare for these new installations, we embarked on a project to thoroughly review the latest technologies and practices available and to update our related standards. The work was largely performed in-house and involved collaboration and review with a consultant experienced in reactor protection. The review included our shunt reactor specifications, standard reactor installation configurations, and reactor protection and control standards. The focus of this paper is on our protection practices and how those influenced primary equipment standards for the reactors and reactor breakers.

The paper discusses reactor fundamentals at a high level. Then we focus on the control system and protection system design and its influence on primary equipment design. The paper also covers Ameren's protection setting criteria and considerations for the future adaptation of our standards to variable reactors.

II. SUMMARY OF REACTOR FUNDAMENTALS

Many references discuss general shunt reactor fundamentals [1] [2] [3]. This section gives a brief summary of concepts that influence protection of solidly grounded line- or bus-connected reactors. Two main attributes of the reactor affect protection:

- Dry-type or liquid-immersed
- Air-core or gapped iron-core

Most air-core reactors are dry-type and most gapped iron-core reactors are liquid-immersed. However, some of Ameren's older liquid-immersed reactors are air-core type. The new standard is designed to work for all reactor types.

A. Dry-Type or Liquid-Immersed

From a protection standpoint, liquid-immersed reactors are enclosed in a tank so turn-to-turn faults can be detected by mechanical protection such as sudden-pressure and Buchholz relays. Dry-type reactors are free-standing in air, so electrical detection of turn-to-turn faults is important.

Liquid-immersed reactors, being enclosed in a tank, have high-voltage bushings where current transformers (CTs) can be installed. CTs are easily available for the high-voltage and grounded neutral terminals of the reactor. CTs on the neutral terminals of each winding, above the neutral wye-point, are also installed inside the tank and used for the reactor phase differential protection. The CTs supplied with the liquid-immersed reactors can be specified to be optimal for the reactor protection, which often needs much higher sensitivity than other protection applications. Often, the CTs installed in transmission circuit breakers have ratios that are too high to meet the protection requirements without severely tapping them down.

Additionally, because all CTs inside the tank are provided by the reactor manufacturer, they will typically be matched CTs from the same CT manufacturer with the same design and characteristics. This is important for improving the security of reactor differential protection. This is covered further in Section VI.B when we discuss the phase differential protection.

On the other hand, dry-type reactors typically require free-standing CTs to be installed. The CTs at each end of the winding that form the differential zone boundary will often be very different designs. The phase CTs at the high-voltage terminals of the reactor zone either must be insulated for the transmission voltage or be mounted in the reactor breaker if it exists. The neutral ends of the reactor windings are grounded so the phase differential CTs at that end of the winding can be a low-voltage class. The likelihood of getting matched CTs is thus reduced.

Dry-type reactors have coils exposed to the environment and are subject to surface contamination. Thus, turn-to-turn faults are more likely. However, as previously noted, mechanical protection cannot be used to detect turn-to-turn faults in dry-type reactors, making an electrical turn-to-turn fault protection scheme important. To implement the electrical turn-to-turn fault scheme, a CT on the neutral ground connection is necessary. This requires that the neutral terminals of the three reactor phases be connected via an insulated neutral bus and then grounded through a single connection such that a neutral ground CT can be installed to measure zero-sequence current (3I0) in the reactor without summing phase CTs [1]. We will talk about the importance of this CT for electrical turn-to-turn fault protection in Section VI.C.

B. Air-Core or Gapped Iron-Core

Gapped iron-core reactors typically have a very high X/R ratio. The gapped iron-core facilitates much greater inductance per turn, resulting in fewer turns and therefore less resistance to obtain a specified reactance as compared to an air-core reactor. Reference [2] reports 700 is a typical X/R ratio for an iron-core reactor while 300 is a typical X/R ratio for an air-core reactor. The X/R ratio of an air-core reactor is still much higher than most other electrical circuits.

We are concerned about the high X/R ratio of a reactor as that defines the system dc time constant: $\tau = L/R$ where τ is in seconds, L is in Henrys, and R is in ohms. The inductance, L , used to determine the dc time constant can be obtained from the reactance, X , by $L = X/(2 \cdot \pi \cdot f)$, where f is the nominal frequency of the reactor in hertz. When the reactor is switched at a point on wave (POW) other than a voltage positive or negative peak, the load current can have a transient dc offset that lasts much longer than for other inductive circuits. The dc offset can drive CTs into saturation, which must be accounted for in CT selection and in protection setting criteria. The impedance of a reactor is usually several orders of magnitude greater than the source impedance of the power system, so the X/R ratio of the power system is neglectable in this evaluation. POW switching controllers are often used with shunt reactors to mitigate concerns with the dc transient on CT performance and transient recovery voltage (TRV) concerns during shunt reactor de-energization [4]. We discuss Ameren's practice on this matter in Section IV.

However, use of a POW controller cannot eliminate the concerns. The controller could be misadjusted and actually make the problem worse [5]. Or, the controller may only perform POW control for opening operations as described in Section IV. Additionally, a dc transient can happen for any disturbance that affects the voltage across the reactor impedance. For example, switching a heavily loaded line or clearing a nearby external fault can cause the voltage to jump.

Air-core reactors must have much greater spacing between phases and between phases and ground because the magnetic flux is not concentrated by the core. For this reason, phase-to-phase and phase-to-ground reactor faults are much less likely. However, protection must be designed to reliably detect such faults. Gapped iron-core reactors are almost always liquid-immersed inside a tank. The close proximity of the energized windings to adjacent phases and the grounded core and tank makes these faults somewhat more likely.

III. CT SELECTION CONSIDERATIONS

Fig. 2 shows a single-line diagram of Ameren's typical transmission-connected shunt reactor installation. The reactors are usually bus-connected and not line-connected. Ameren's application is for general transmission voltage control and not for Ferranti effect on long lines that can experience overvoltage at an open terminal when energized from the other end. In ring bus substations, the reactor circuit is typically given its own ring position. For breaker-and-a-half arrangements, the reactor circuit is connected to a bus. There will always be a dedicated reactor breaker with a POW switching controller. Further, the

reactor breaker allows selective tripping of the reactor zone without having to open the ring or bus.

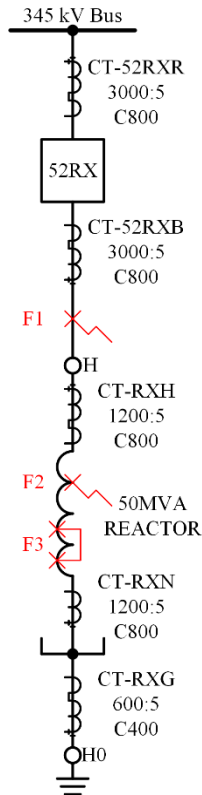

Fig. 2 Ameren reactor installation. Only one set of redundant CTs is shown at each location to reduce clutter.

Fig. 2 is used to discuss how we have eliminated the challenge of sizing CTs to optimize protection without having to make difficult compromises. A large part of [1] focused on CT selection. The CT selection criteria proposed in [1] were as follows:

- Provide adequate sensitivity to detect 10–15% of reactor rated current.
- Size the CT accuracy class voltage rating to prevent asymmetrical saturation on switching. This is a low current, but with a long dc time constant.
- Size the CT accuracy class voltage rating to limit saturation for the maximum internal fault current condition to a reasonable level. Otherwise, this problem can result in insufficient current to pick up high-set elements.

The challenge outlined was to balance a CT ratio that could be low enough to provide the stated high level of sensitivity but high enough to provide adequate CT performance with the long dc transient. The 10–15% of reactor rating is required by the sensitive turn-to-turn fault scheme that uses an impedance-based ground directional element. Note that the recommended sensitivity range for this scheme differs slightly between references, but all fall in the range of 5% to 15%. In the following discussion, we will use 10% for simplicity. The relay used at the time was a standard three-phase multifunction line relay that used the calculated 3I0 residual of the three-phase CT inputs. This forced the need for the CTs used for phase fault and

turn-to-turn fault protection to provide that degree of sensitivity.

The innovative new protection system design described in this paper allows Ameren to separate the protective elements for the three faults illustrated in Fig. 2 so that their signals come from different CTs—each optimized for the fault that it must detect.

A. Fault F1

The red symbol labeled F1 in Fig. 2 includes phase and ground faults in the bus work connecting the reactor breaker, 52RX, to the terminals of the shunt reactor. The area for F1 faults extends into the top coils of the reactor. These are system-level faults that are not limited by the impedance of the reactor. The 3000:5 CTs, CT-52RXX, in the breaker are appropriate for protective elements designed for this portion of the zone of protection. Faults in the F1 area drove the third criterion in the previous list.

Originally, Ameren planned to specify the reactor breaker with 3000:5 CTs on one side, labeled CT-52RXB in Fig. 2, for the bus protection zone and 1200:5 CTs on the other side, CT-52RXX, for the reactor protection zone. This was not desirable for several reasons. Spare breakers for reactor application would not be available. By eliminating the need for the lower ratio CTs, a spare breaker with CTs specified for general transmission applications could easily be modified by adding a POW controller if needed. Another concern is that having different CTs on each side of the breaker increased the possibilities of human performance issues that might result in the breaker being oriented the wrong way when installed.

B. Fault F2

The red symbol labeled F2 in Fig. 2 includes phase and ground faults in the reactor windings. The target sensitivity for this protection is around 100% of reactor rated current. This reduces the sensitivity requirement by a factor of 10 relative to the 10% target required when the reactor phase CTs were required to supply both the differential protection and the sensitive turn-to-turn fault protection. Section VI.C explains the sensitivity target in detail.

With a target sensitivity 10 times higher, satisfying the second criterion in the previous list can be done with little compromise. CT ratios for the reactor CTs, CT-RXH and CT-RXN, can easily be selected. In Ameren's application, rated current for a 50 MVA, 345 kV reactor is 84 A. The reactors are specified with 1200:5 phase CTs. These CTs are oversized by a factor of 14. Such oversizing significantly reduces concerns with CT performance issues.

For dry-type, air-core reactor applications, the authors advocate for installing free-standing phase CTs at the high-voltage terminals of the reactor as opposed to relying on the breaker CTs for the reactor differential protection. However, the 10 times improvement in the required ratio for the phase CTs may make use of the breaker CTs viable in many applications.

C. Fault F3

The red symbol labeled F3 in Fig. 2 covers reactor turn-to-turn faults. The differential protection on the reactor is blind to these faults, so a separate scheme is required. The multifunction relay used in the Ameren standard allows this protection to use only signals from the reactor neutral ground CT, CT-RXG. Recent changes to the zero-sequence impedance directional elements in the relay that Ameren uses [6] now allow it to be set to make a reliable directional decision with negligible zero-sequence voltage (3V0). See Section VI.C and [7] for why this is important for this application. So, only the grounded neutral CT, CT-RXG, must be sized for the high sensitivity. This CT does not need to be sized for continuous load current and satisfying the first criterion can be done with little compromise. In Ameren's application, 10% of rated current for a 50 MVA, 345 kV reactor is 8 A. The reactors are specified with a 600:5 CT on the grounded neutral bushing. Section VI.C explains the sensitivity target in detail.

The CT-RXG shown in Fig. 2 is extremely important for this highly sensitive scheme. In Ameren's typical application, the tripping element is set to trip on 5 A primary of 310 unbalance current. The ground CT measures pure 3I0 and is immune from false residual from summing three-phase CTs. Errors caused by the inevitable CT saturation from the long time-constant dc transient may be significant relative to the tripping setting for this protection. Using a neutral ground CT to eliminate that source of error is important.

IV. SWITCHING CONTROL DESIGN

As mentioned in Section II, POW switching is often used with shunt reactors. POW switching can be used to mitigate breaker restrikes during shunt reactor disconnection and reduce inrush and/or the dc transient during shunt reactor energization.

Breakers can experience a restrike because of uncontrolled shunt reactor disconnections as discussed in [8] and as summarized here. When a reactor is disconnected, the reactor residual voltage will oscillate at a high frequency determined by the inductance and stray capacitance. If the current is interrupted before the zero crossing and the contacts have not parted to maximum, the oscillating reactor voltage will have a higher amplitude and rate of change than the system voltage and the TRV capability across the breaker contacts can be exceeded. When the breaker TRV is exceeded, a restrike is probable. These transient overvoltages can stress insulation in the reactor windings and surrounding equipment. The high-frequency re-ignitions will be unevenly distributed across the reactor winding with the highest stress placed near the HV bushings, which can puncture insulation or cause turn-to-turn faults.

Reference [8] states that surge arresters will only protect the reactor to a limited extent because the severity of the voltage stress is related to both the rate of change and the magnitude. Some utilities purchase breakers or a specially designed circuit switcher with higher TRV withstand capabilities [9]. However, this would require purchasing non-standard breakers or devices. Another option is to use controlled opening available in a POW controller [4] [8]. To mitigate restrikes and preserve

equipment insulation, POW switching is used for controlled opening operations for reactor applications at Ameren. The standard breakers can be purchased with a POW controller installed, and the POW controller can be installed on a spare standard breaker. The POW controller is programmed with the known contact parting time, which also includes the time to energize the trip coil. The POW controller will monitor the reactor current phase angle and issue an advanced angle open command to the breaker such that its contacts will part just after a current zero and so that the contacts have been separated as far apart as possible at the next current zero (voltage maximum). This ensures the maximum dielectric strength is available during current interruption to prevent a restrike [4] as shown in Fig. 3.

The reactor breaker must have independent pole operators so the opening command can be optimized for each phase of the shunt reactor. T_{command} comes in at a random time. The controller waits for a zero crossing of the current in that phase, T_w , and then delays an additional time, T_{cont} , based on the mechanism opening time, T_{opening} , such that the interrupter's contact separation occurs just after a current zero crossing. This gives the mechanism as much time as possible to part the contacts such that by the next zero crossing, it has traveled as far as possible in that half cycle. $T_{\text{cont}} = N \cdot T_{\text{zero}} - T_{\text{arcing}} - T_{\text{opening}}$, where N is the number of zero crossings required to make T_{cont} positive, T_{zero} is the time between zero crossings, and T_{arcing} is slightly less than the time between zero crossings.

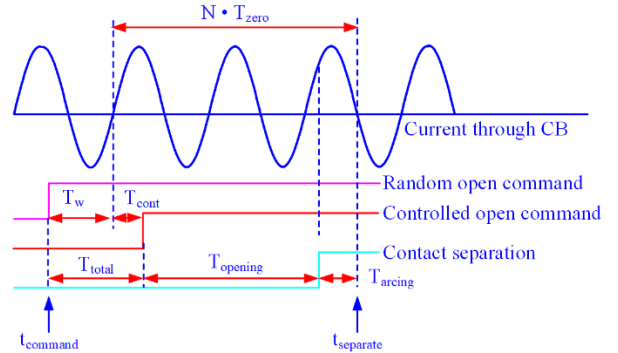

Fig. 3 A reproduction of Fig. 1 in [4]. Controlled opening sequence.

Protection trips bypass the POW controller per the recommendations of [8]. This is done so the POW controller will not prevent or delay a protection trip from opening the breaker.

Presently, Ameren does not use the POW controller to perform controlled closing. Controlled closing will reduce inrush currents minimizing equipment stress and help prevent nuisance tripping of the protection system [8]. Ameren has not had issues with nuisance tripping or equipment stress due to inrush of reactors, so controlled closing has not been adopted. Section VI.B explains that our setting philosophy mostly eliminates the concern of nuisance tripping.

Transmission network configurations where the shunt reactor breaker is closed but the connected system is de-energized can occur. To prevent energizing a reactor during system restoration, a three-phase undervoltage element is used to trip the reactor circuit breaker. The time delay is selected to

ride through system transients and trip before transmission reclosing occurs. The undervoltage trip bypasses the POW controller. This is done because the POW controller will not sense current, and it uses current to determine the optimal time to open each pole of the reactor circuit breaker.

As stated in Section II, reactors are used to reduce system voltages. Ameren uses automatic control where the reactor is automatically switched on at system voltages that are determined via a system study. An unconditional overvoltage close is also used and is set at 110% and time-delayed to ride through system transients but also before standard arrester temporary overvoltage (TOV) curves are exceeded.

V. PROTECTION DESIGN

This section establishes protection requirements for solidly grounded shunt reactors connected to Ameren's EHV transmission system. The guidelines described here allow for reactor faults to be cleared rapidly because there is potential for substantial damage in a very short period. They also provide for all faults to be detected by two separate relaying schemes.

The types of faults that Ameren designs reactor protection to detect are shown in Fig. 4. This three-line diagram provides more detail than the single-line diagram in Fig. 2.

Faults 1 and 2 in Fig. 4 correspond to F1 in Fig. 2. Faults 3, 4, and 5 in Fig. 4 correspond to F2 in Fig. 2. Fault 6 in Fig. 4 corresponds to F3 in Fig. 2.

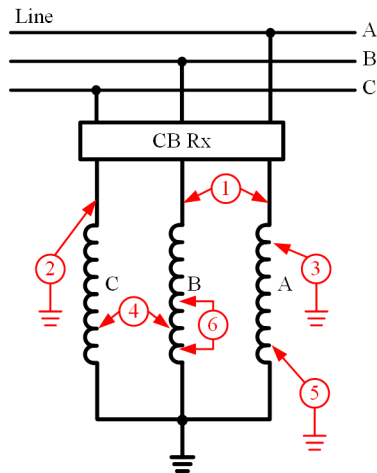

Fig. 4 A reproduction of Fig. 2 in [1]. Types of faults in a shunt reactor.

A review of reactor fault physics can be found in [10]. This reference explains the autotransformer effect where voltage in the healthy turns couples to the faulted turns and causes higher currents than might otherwise be expected. The effect is less pronounced in air-core reactors but still exists to a degree. The following paragraphs contain a discussion of expected fault magnitudes.

Phase-to-ground (Fault 2 in Fig. 4) and phase-to-phase (Fault 1 in Fig. 4) faults between the reactor circuit breaker and reactor bushings are only limited by the system source impedance. These faults will generate high-magnitude fault currents and must be cleared rapidly to maintain coordination margins with overreaching transmission line relaying protection.

The magnitude of winding-to-ground faults (Fault 3 and Fault 5 of Fig. 4) within the reactor depend on the location of the fault in the winding. For faults near the reactor bushings, fault magnitudes will be limited by the source impedance. For faults near the neutral of the reactor, the faulted phase current as measured by the reactor bushing CTs (CT-RXH in Fig. 2) is limited by the impedance of the reactor. The three-phase set of neutral CTs will measure current due to the autotransformer effect [10]. In addition, ground current will flow in the neutral. The neutral terminal currents may be very high for a gapped iron-core reactor due to the high permeance of the core. The neutral terminal currents for an air-core reactor are expected to be low due to the low permeance of the core. See [11] for a review of magnetic circuits and permeance. All faults within the tank will generate pressure inside the tank and must be cleared quickly to prevent rupture.

Winding-to-winding faults (Fault 4 in Fig. 4) within the reactor are expected to be rare in occurrence for dry-type air-core reactors due to winding spacing being significant. The magnitudes of the fault currents are expected to be similar to winding-to-ground faults, except there would be no ground current that would flow in the neutral.

Turn-to-turn faults (Fault 6 in Fig. 4) within the reactor are expected to result in relatively small changes in magnitudes from load current, depending on the number of turns involved. However, the fault current in the shorted turns can be hundreds of times the rated reactor current [10]. A turn-to-turn fault in one winding would result in asymmetry in the per-phase reactance, which would result in unbalance currents and ground current in the neutral.

As viewed in the substation yard, a liquid-immersed reactor does not differ much from a power transformer. However, due to the construction and operation of a reactor, the protection of a reactor is quite different [1] [2] [3] [10]. The differences are discussed here at a high level. Greater detail is provided when discussing the various protective elements.

- Turn-to-turn faults cannot be detected by the phase or negative-sequence differential elements commonly available in transformer protection relays [1]. Power transformer differential relaying measures ampere-turn balance (ATB). Reactors do not have a primary winding magnetically coupled to a secondary winding, and hence differential protection will not respond to a turn-to-turn fault on a reactor. A phase differential applied on a reactor performs a Kirchhoff's current law (KCL)-based differential and will respond to all fault types except turn-to-turn. Similarly, unbalance current caused by a turn-to-turn fault appears as through current so the REF protection often applied to transformers cannot detect these faults.
- Gapped iron-core reactors experience inrush while air-core reactors do not. Unlike a transformer differential based on the principle of ATB, inrush appears as through current for the KCL differential. Inrush in a gapped iron-core is significantly less than for a transformer. The gapped core has a higher knee point

For security, the 50P element would be set above the maximum expected load current with a security margin. A gapped iron-core reactor experiences inrush but it is much smaller in magnitude than for a transformer with a solid core. Reference [3] indicates that peak inrush current for a gapped iron-core reactor is in the range of 3 to 5.5 times nominal current. An estimate of the fundamental frequency reactor current during inrush can be obtained by taking the maximum typical peak current (5.5) divided by 2 to account for offset, then dividing by $\sqrt{2}$ to convert it from peak to fundamental RMS. This gives a maximum reactor current during inrush of around 2 pu. This simple assumption of the fundamental magnitude being equivalent to an offset sine wave is conservative. Reactor inrush has very little distortion, so using this simplifying assumption overestimates the fundamental for a relay that filters out the harmonics. Ameren has not observed inrush higher than 1.5 pu fundamental component, so we are confident that this estimation is conservative.

For a gapped iron-core application, the security limit for the 50P element, using a security margin of 2, would be 4 pu (2 times the expected maximum inrush current). For an air-core reactor, the security margin would have to account for maximum load current during high voltage or for rise in voltage on healthy phases during a nearby fault. A security margin would be applied to the maximum load current to find the security limit. A security margin of 2 would be typical.

In most applications, these two limits will allow a large range in which to select a secure and dependable setting for the 50P elements. Reference [1] suggests a pickup of 50% of the minimum line-to-line fault under N-1 source conditions. It also suggests a 50N element set to 50% of the minimum line to ground fault under N-1 source conditions. The 50N residual overcurrent element would only be necessary if there was a significant difference between phase and ground fault levels and the 50P element could not be set for both types of faults. Ameren has not seen a need to use more than the 50P element for this protection.

The 50P element will reach into the first few coils of the shunt reactor. This is of little concern and ensures overlap for these high-grade faults between the F1 protective elements and the F2 protective elements.

Some relays can be purchased with a second differential element [12]. This makes it possible to use a differential element for the F1 faults instead of a 50P element and precisely limit the coverage to the zone boundary provided by the CT-RXH CT shown in Fig. 2. Ameren does not see much value in this enhancement and does not use it.

B. 87P – Phase-to-Phase, Phase-to-Ground, Winding-to-Ground, and Winding-to-Winding Element Criteria

Phase differential protection is required to detect phase-to-ground and phase-to-phase faults in the reactor. This section delves into the special nature of reactor differential applications, including the type of differential to be applied and how the element should be set.

C37.109 provides wide-ranging guidance on how to set the 87P element. The text says you can either set the minimum pickup in the range of 0.20–0.75 pu of reactor rating, or 0.5–

1.0 pu of reactor rating. As you can see, two widely overlapping ranges are given. The setting range of 0.5–1.0 pu came from [1], which was written in 2013. The paper states this range but is terse on how this range was arrived at. This section provides a more detailed explanation that supports the original recommendation based on what was known by the authors of [1] then and what has been learned since.

1) Type of Differential Element Required

There are two main types of differential elements: KCL differential elements and ATB differential elements.

While a gapped iron-core reactor appears to be constructed very similar to a transformer, a transformer differential zone is characterized by the fact that at least some of the zone boundaries are connected to the others by the magnetic circuit of the core. Such differential elements work on the principle of ATB around the magnetic circuit of the core [11].

The magnetic core introduces significant compromises to the ATB differential element because the element must be secured from false operation when the core experiences saturation. While largely neglectable during normal operation, excitation current becomes significant under inrush and overexcitation conditions. Security features naturally slow the differential element and a high-set unrestrained differential element is used in parallel to improve speed and dependability [13].

KCL differential is traditionally associated with bus applications where all boundaries of the zone are galvanically connected. As shown in Fig. 5, the differential zone is bounded by phase CTs at the high-voltage terminals of the reactor, CT-RXHP, and by phase CTs at the neutral terminals of the reactor, CT-RXNP. The zone boundaries are galvanically connected just like a bus. Thus, reactor applications require a KCL type differential element. With no need to be secured from core saturation affects, the speed performance of KCL differential elements is high. Most transformer differential relays can be configured to perform like a bus differential relay by turning off the inrush and overexcitation security features [12]. Ameren uses a multifunction transformer differential relay in their standard but turns off the harmonic and waveshape recognition security features so that it performs as a KCL differential.

To summarize, a KCL (bus type) differential element is preferred over an ATB (transformer type) differential element for reactor phase differential protection. The application is simpler given that there is no need for supplementing it with an unrestrained element, and the element is both faster and simpler because there is no need to be secure against inrush and overexcitation.

2) Nature of a Reactor Differential Application

There are many more characteristics of shunt reactor differential protection that are uniquely different from transformer applications.

Let's look at the nature of the current through the differential zone. The current through the zone is quantified as the restraining signal when applied to the percentage restraint slope characteristic [14]. Through faults are one of the greatest security challenges for most differential applications. This is

not the case for a reactor differential. The reactor differential zone boundaries are each end of the reactor winding. The through current is driven by ohms law where $I = V/X$. For now, as a simplifying assumption, let's assume that the shunt reactor is an air-core type. The reactance, X , can be considered a constant over an extended operating voltage range so the current is proportional to the applied voltage. If the application is a gapped iron-core, the knee point of the core is typically in the range of 1.25–1.35 pu of rated voltage so the impedance is linear for all normal operating conditions [8].

As mentioned in Section A, a gapped iron-core reactor can experience inrush that can cause the current to be transiently higher than the normal load current. However, it is important to understand that, for a reactor differential, the inrush appears as through current, unlike for a transformer differential where inrush appears as operate current.

When there is an external fault, the voltage on the faulted phase(s) is depressed so the through current typically goes down on the faulted phases during an external fault. The voltage on the healthy phases can be higher than nominal during a nearby fault. Even if we factor in a conservative assumption of 1.3 for an effectively grounded system, we see that the maximum through current in the zone for an external fault is limited to only a little more than the reactor's nominal rating. The percentage restraint slope characteristic's important attribute is that it requires progressively more differential current the higher the through current. The slope characteristic is of little value because the maximum through current does not increase significantly above the reactor's nominal rating. This was also the conclusion for slope guidelines in [1].

The most significant concern with reactor differential is the high X/R ratio of the circuit. Because the reactor impedance is typically orders of magnitude greater than the system impedance, the X/R ratio of the transmission system is neglectable in this discussion. The flux density in the core of a CT is a function of the volt-time area in the CT secondary circuit [15]. When the current has a dc offset, the flux density ratchets up and can cause any CT to be driven into saturation. The X/R ratio affects the time constant of the dc transient in the reactor current.

As we have discussed, the only through current that affects the differential zone is reactor load current, which is proportional to the voltage applied (except during inrush for a gapped iron-core reactor where it is transiently higher). The magnitude of the dc transient is determined by the point on the sine wave where the change in voltage occurs across the reactor.

Reference [16] examines the volt-time area equation (1) from [17].

$$20 \geq \left(\frac{X}{R} + 1 \right) \cdot I_f \cdot Z_b \quad (1)$$

where:

I_f is the maximum fault current in per unit of CT rating.

Z_b is the CT burden in per unit of standard burden.

X/R is the X/R ratio of the primary fault circuit.

The authors observed that the equation has two main terms:

- The voltage that the CT has to reproduce, which is a function of the magnitude of the worst-case current (I_f) times the secondary burden impedance (Z_b).
- The $(X/R + 1)$ term, which determines how long the dc transient will last.

The equation assumes a fully offset current waveform as the boundary condition. Reference [16] observes that a CT that saturates due to a high $I_f \cdot Z_b$ term and a low $(1 + X/R)$ term will quickly go into saturation, go deeply into saturation, and quickly recover. The differential element requires a high slope characteristic to accommodate this application. However, a CT that saturates due to a high $(1 + X/R)$ term and a low $I_f \cdot Z_b$ term slowly goes into saturation but does not go into severe saturation. The differential element does not require a high slope to accommodate this application. Most discussions of CT saturation and its effect on protection focus on the high fault current scenario. However, [18] does focus on CT saturation from dc in the current signal. It confirms the observation that the fundamental ac component errors from dc saturation are not very large.

Next, let's examine another attribute of the reactor differential zone. The differential is a KCL type differential with only two terminals: the high-voltage terminal and the phase neutral terminal of the reactor winding. Thus, the current in each CT for any external event is the same. The old advice to always use matched CTs in a differential circuit is not particularly valid for most differential applications. But, for a two-terminal KCL differential application such as a reactor or electric machine stator, this advice has merit.

The advice is based on the assumption that, if the currents are equal and the burdens are equal, identical CTs will have similar errors and, therefore, the errors will cancel, reducing any false differential current from CT saturation. In most cases, the burden loop for the CTs is dominated by the cables connecting the CTs located at the primary equipment to the differential relay located in a substation building. Therefore, the difference in the impedance of the burden loops is likely neglectable in most applications.

What is meant by matched CTs? Obviously the CTs should be of the same ratio and accuracy class. However, [19] explains that, depending on the choices of the CT design engineer to meet the accuracy class specifications, different CTs of the same class can have different transient errors. In Ameren's case, using liquid-immersed, gapped iron-core reactors, it can be assumed that the CTs are supplied with the reactor and are from the same manufacturer with the same design specifications. As stated, Ameren specifically uses the CTs on the reactor for the differential protection and not the CTs on the reactor breaker for this very reason. For air-core reactors, this is typically not the case and could affect selection of the minimum pickup.

Finally, [3] and [20] mention a "transformer effect" that increases differential current for the reactor differential element. We call this an "autotransformer effect" but we are talking about the same thing. Voltage from the healthy windings couples to the faulted windings, which increases current flow in the faulted turns. The autotransformer effect will

also increase current in the turn-to-turn fault scheme. See Section C for details on the impact for detecting turn-to-turn faults. For gapped iron-core reactors, [21] indicates that the differential current will be significantly higher than reactor rated current for faults anywhere in the windings and there is no benefit to setting the differential characteristic low. A recent paper examined this coupling between healthy and faulted turns for both gapped iron-core and air-core reactors [10]. The autotransformer effect is also expected in air-core reactors but to a lesser extent due to the lack of a magnetic core to increase the mutual coupling along the entire winding.

3) Development of the 0.5–1.0 pu Setting Range

Now that we have provided needed context, we can use that information to evaluate the original guideline. All discussions of relay setting criteria must start with remembering that there are generally two limitations that must be balanced: a security limit and a dependability limit. We also assume that all modern relays adequately reject the dc component when filtering to measure the current signals.

a) Security Considerations

Let's consider the security limit first. How sensitive is too sensitive? We have established that the main concern with misoperation of a reactor differential element is that, when remanence is considered, it is impossible to rule out CT saturation. False differential comes from the difference in performance of the CTs reproducing the same primary current and we would like to set the differential element above any anticipated performance difference. We know that the maximum through current is not much higher than nominal load current. The worst case is during inrush if the reactor has a gapped iron-core. If we set the minimum pickup above 1 pu of reactor rating and assume that one CT performs perfectly and the other CT saturates almost completely, the element should be secure. Of course, this extreme case is not credible. First of all, we understand that dc saturation does not result in very high fundamental frequency error [18].

A setting of 0.5 pu at the low end of the range would accommodate up to 50% difference in CT performance. This seems to be a very conservative margin for matched CTs. The case study of a reactor differential misoperation described in [5] not only had dissimilar CTs at each zone boundary, but the CT lead lengths were very different at 40 meters for one set and 120 meters for the other set. In this case and subsequent follow up field tests, the differential current never exceeded 0.4 pu. In the interest of biasing for security, a higher security margin may be warranted for applications such as this.

In [5], the reactor differential element was set at around 0.22 pu, which is a typical setting for a transformer differential element. Instead of raising the minimum pickup, they raised the slope setting to 30% to mitigate the problem. A setting of 30% would correspond to a minimum pickup of 0.6 pu at reactor nominal rated current for the differential relay they used.

b) Dependability Considerations

We also need to consider dependability criteria before deciding on a setting. It seems that setting the minimum pickup above 1 pu so that we simply do not need to think about security from load current saturation gives people concern. We have

been taught that transformer differential elements must be set as sensitively as possible to detect partial winding faults where the autotransformer effect steps the current in partial winding faults down to very small values at the terminals of the transformer [22].

But remember, this is a KCL differential with load current measured in the reactor windings. As the KCL differential element is completely blind to turn-to-turn faults in the windings, any fault that it is responsive to will involve current flowing into the high-voltage terminal of the winding but not out of the neutral terminal of the winding. This is unlike a turn-to-turn fault in a transformer winding that upsets the ATB of the differential. That is a significant driver for the need to set a transformer differential element to be as sensitive as possible that simply does not apply to a reactor differential element.

To further make the case for why the differential element for a reactor does not need to be set extremely sensitive where it is vulnerable to false differential from dissimilar CT performance, we start with simplifying assumptions and comment as to whether these assumptions are conservative or the opposite to the conclusions we are intending to obtain.

- Assume that Z_{RX} is 1.0 pu and the Z_{SRC} is 0.01 pu. In most cases, Z_{SRC} will be at least two orders of magnitude smaller than Z_{RX} .
- Assume the fault current enters the high-voltage terminal CT and does not exit the neutral terminal CT (bolted fault). This is not a conservative assumption. The current may divide with some flowing through the fault path, and some flowing through the shorted winding to the neutral terminal CT, meaning that the differential current could be less.
- Assume that there is no autotransformer effect with voltage from the healthy turns coupling to the shorted turns. This is a conservative assumption.
- Assume the minimum pickup is set at 0.75 pu, the middle of the 0.5–1.0 pu range given in [1].
- All faults are winding to ground. Similar analysis can be done for winding-to-winding faults, but that isn't necessary to make the point.
- Assume that Z_{SRC} and Z_{RX} have equal positive-, negative-, and zero-sequence impedances.

The calculation for fault current under these simplifying assumptions is given by (2). Because of the simplifying assumption that there is no autotransformer effect and that the faults are bolted, fault current equals operate current.

$$I = \frac{V}{(Z_S + [1-m] \cdot Z_R)} \quad (2)$$

where:

$$V = 1 \text{ pu.}$$

$$Z_S = 0.01 \text{ pu.}$$

$$Z_R = 1 \text{ pu.}$$

m is fault location in pu.

Let's look at fault locations along the winding using these assumptions as shown in Table I.

TABLE I
REACTOR DIFFERENTIAL CURRENT

% of Winding	Differential Current	> 0.75 pu?
100%, m = 1.00	100 pu	Yes
10%, m = 0.10	1.10 pu	Yes
1%, m = 0.01	1.00 pu	Yes
0%, m = 0.00	0.99 pu	Yes

Here are some observations:

- A fault simply shunting the current away from the neutral terminal phase CT provides near 1.0 pu differential current.
- Selecting a setting closer to the middle of the range provides a lot of security for differential current from unequal CT performance during reactor switching and plenty of accommodation for current division between the fault path and the faulted turns of the reactor.
- If you factor in the autotransformer effect causing significant current flow in the neutral terminal phase CT, margin to accommodate current division is likely not needed.
- If the reactor is a gapped iron-core type, perhaps the recommended range could be raised to 1.0–2.0 pu. This would give greater immunity to operating on false differential during inrush and take advantage of the more significant autotransformer effect brought by the gapped iron-core. However, with matched CTs, as is often the case with a liquid-immersed, gapped iron-core reactor, greater security margin is probably not necessary.

4) Summary of Ameren's 87P Setting Criteria

Ameren uses the guidance from [1] and sets the 87P pickup between 0.5–1.0 pu for gapped iron-core reactors with the additional requirement to look at the pickup in secondary amps and ensure it is not set lower than 250 mA; however, 500 mA is preferred. The 87P pickup is set no lower than 250 mA to provide security for cases where there is excessive noise that is coupled to the CT secondary cables. This can occur if a CT secondary shield ground is inadvertently lifted, or it was not connected.

For air-core reactors, the 87P pickup maximum dependability limit is left at 0.75 pu because the autotransformer effect is assumed to be lower due to the low permeance of air. If the pickup is set no lower than 0.5 pu, [1] says that the specific slope setting is not critical. However, Ameren uses a slope of 35% per the simulations performed in [10]. This provides additional security during inrush. Inrush has been observed to be around 1.5 pu, which makes restraint equal 3 pu. Three pu times 35% equals 1.05 pu false differential to trip. As a conservative check, the CT dimension factor introduced in [10] is verified to be greater than 70 for each installation. The 87P pickup criteria is summarized in Table II.

TABLE II
87P WINDING-TO-GROUND FAULT PROTECTION ELEMENTS CRITERIA

Element	Setting Criteria
87P (gapped iron-core)	0.5–1.0 pu (set no less than 250 mA)
87P (without a gapped iron-core)	0.5–0.75 pu (set no less than 250 mA)
Slope	35%

C. 67N – Turn-to-Turn Fault Protection Element Criteria

Electrical turn-to-turn fault protection is required to back up mechanical methods of detecting turn-to-turn faults. This section delves into the special nature of reactor electrical turn-to-turn fault applications, including a history of turn-to-turn fault practices at Ameren, turn-to-turn fault protection element requirements, proposed scheme, pickup criteria, CT saturation effects on performance, miscellaneous supervisions, and other considerations.

1) History of Turn-to-Turn Fault Protection Practices at Ameren

With the increased need for reactors on the system, previous reactor protection practices at Ameren were reviewed in accordance with [1] [2] [3] [10]. Many installations had single Buchholz or sudden pressure relays installed on existing liquid-immersed reactors. It is desirable to have redundant protection systems to detect all faults so that equipment remain in-service following discovery of a failure of a single component of a protection system. Turn-to-turn faults are the most common fault within a reactor, and this is also illustrated in a survey conducted by CIGRE in [8]. If not detected, turn-to-turn faults may develop arcing, leading to combustion in the oil, severe winding damage, and possibly even a tank rupture [2]. For dry-type reactors, the urgency to detect turn-to-turn faults is less pronounced due to the absence of combustible oil and a rupturable tank [2]. The desire to have redundant protection to cover turn-to-turn faults on new installations and a new understanding of the consequences of an undetected turn-to-turn fault prompted a change in the standard relaying practices for reactors.

2) Turn-to-Turn Fault Protection Requirements

As discussed in Section V, turn-to-turn faults within the reactor result in small changes in magnitudes from load current. A turn-to-turn fault in one winding would result in asymmetry in the per-phase reactance, which would result in unbalance currents and ground current in the neutral. With this understanding, it was known that an unbalanced current scheme could be used to detect this type of fault. In the search for a new electrical turn-to-turn fault protection scheme, the negative- and zero-sequence directional overcurrent methods (67Q/67N) were reviewed in C37.109 [2]. Fig. 6 is drawn based on Fig. 14 of [2] but is modified for the purposes of this paper:

The scheme in Fig. 6(a) uses a negative-sequence directional overcurrent (67Q), which uses negative-sequence voltage (3V2) measured from the bus voltage transformers (VTs) and negative-sequence currents (3I2) measured from CT-RXH to determine if the fault is external or within the reactor. The 67Q

scheme directionally controls a ground overcurrent element from CT-RXG.

The scheme in Fig. 6(b) uses a zero-sequence directional overcurrent (67N), which uses 3V0 measured from the bus VTs. For this scheme, the user can use 3I0 currents measured from the three-phase set of CTs (CT-RXH, Option #1 in Fig. 6[b]). This is typically necessary if a multifunction directional overcurrent feeder relay is applied. Or, because it is best to use the neutral CT (CT-RXG, Option #2 in Fig. 6[b]) as discussed in Section III, another method needed to be devised to get a multifunction relay's ground directional element to use this CT.

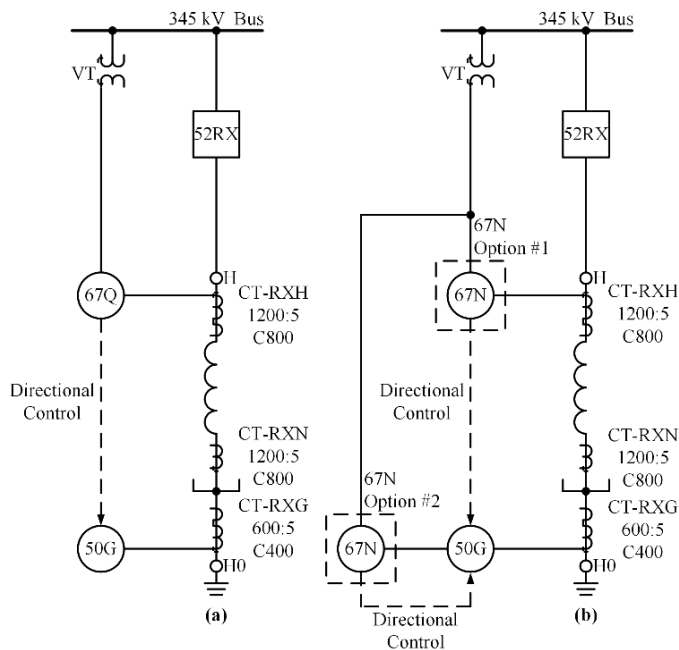

Fig. 6 (a) Turn-to-turn fault protection for grounded reactor using negative-sequence directional control; (b) turn-to-turn fault protection for grounded reactor using zero-sequence directional control.

Upon review of the schemes for turn-to-turn fault protection discussed in C37.109, it was not obvious how to implement this in Ameren's standard relaying package, so the requirements for a new turn-to-turn fault element presented in this paper is discussed. Inspection of Fig. 6 confirms that an unbalance scheme is required (either responsive to 3I0 or 3I2). An unbalance scheme's security may be challenged from several sources as follows:

- False unbalance current from summing CTs to get them. Fig. 6(a) scheme and Fig. 6(b) Option #1 scheme are susceptible to this. If a pure zero-sequence scheme is used that is similar to Fig. 6(b) Option #2, this concern is eliminated. It is highly recommended to use this CT to measure ground current for both tripping and directional control rather than the summation of currents from CT-RXH because it prevents misoperation caused by false 3I0 current resulting from uneven saturation of the phase CTs during energization [1].
- Magnetizing inrush can cause legitimate 3I0 and 3I2 currents in an unfaulted gapped iron core reactor due

to unequal saturation of the iron core or following fault clearing. Concern for mis-operation caused by this natural source of unbalance current is eliminated by using inrush suppression logic as found in [1] [8] [10] [20]. For air-core reactors there is no saturable core, so no 3I0 will flow in the neutral during energization or following fault clearing and this logic may be unneeded.

- The power system recovering from a disturbance may be unbalanced. An impedance-based directional element will reliably determine if the issue is within the reactor or the system [1] [7].

Dependability requirements are discussed next. Unbalance currents caused by turn-to-turn faults in the reactor do not typically create significant unbalance in the system voltages [1] [3] [7], which means that the directional turn-to-turn fault scheme must be able to detect a turn-to-turn fault with near zero system unbalance voltages. Neither of the schemes in Fig. 6, which use directional elements that operate on the product of unbalance voltage and unbalance current, will detect this. An impedance-based directional element set at half of the reactor impedance allows the directional element to easily determine if unbalance current is caused by external faults or an internal fault [1] [7].

Per C37.109 [2], the sensitive turn-to-turn fault scheme is set between 5–15% of reactor rating. With a pickup requirement this low, this would not cause any voltage drop across the source impedance of the system [1] [12]. With an unbalance current pickup set to be so sensitive, the directional element must be able to trip with zero-polarizing voltage. That is why an impedance-based directional element is suitable for this application [7] [12].

3) New 67N Element For Reactor Protection

With an understanding of the turn-to-turn fault element requirements, Ameren began to evaluate the turn-to-turn fault scheme that used a zero-sequence impedance-based directional element (which also used the three-phase set CT-RXH to measure 3I0, Fig. 6[b], Option #1) to directionally control the neutral ground current described in [1]. After evaluating the scheme, it was realized that to achieve a desired sensitivity of 5–15% in [2], the three-phase CTs used in the 87P element would have to be tapped at a low value. For Ameren's application, the CT-RXH CTs would need to be tapped down to 50:5 assuming a minimum acceptable pickup of 500 mA. Reference [1] warns the user that tapping the CTs this low for use of the 87P element should only be used with caution. Reference [1] provides two options for this scenario: either use a higher CT ratio with 1 A nominal relays or accept a loss of sensitivity for turn-to-turn faults. Neither option is preferred due to the consequences of an undetected turn-to-turn fault, and several turns would need to short before a severely desensitized element would operate. In addition, Ameren does not stock standard 1 A relays. With the use of 1 A nominal relays, there is a high likelihood that a failed 1 A nominal relay could be replaced by a 5 A nominal relay by accident or vice versa. In addition, maintenance personnel are used to checking the analog-to-digital converters of microprocessor relays by

injecting a known test current assuming a continuous rating of 5 A nominal. If maintenance injects 5 A nominal for an extended period, a 1 A relay input may be damaged due to exceeding its continuous thermal rating.

At this stage, it was desirable to determine how a scheme similar to 67N Option #2 in Fig. 6 could be used because it would decouple the turn-to-turn CT requirements from the 87P CT requirements as discussed in Section III and [12]. Ameren desired to use the same relays for their reactor protection standard as used for their transformer protection to avoid needing an additional standard relay. After reviewing the standard transformer protection relay manual [6], it was noticed that the relay had a minimum 3V0 requirement for the zero-sequence impedance directional element (32V) to operate, which would block the element from operating for a turn-to-turn fault involving just a few turns because the bus voltage would remain unaffected. At this point Ameren contacted their relay manufacturer, who agreed to modify the impedance-based directional elements in that model relay such that the minimum 3V0 supervision could be set to zero as is consistent with the directional elements in their other relays. They agreed to make the change so the relay could be used in our new standard to detect turn-to-turn faults.

With that commitment, the authors began a collaborative effort to implement the sensitive turn-to-turn fault protection scheme for reactors, which addresses the issues and requirements discussed in Section III. The scheme was implemented using the zero-sequence directional element shown in Fig. 7.

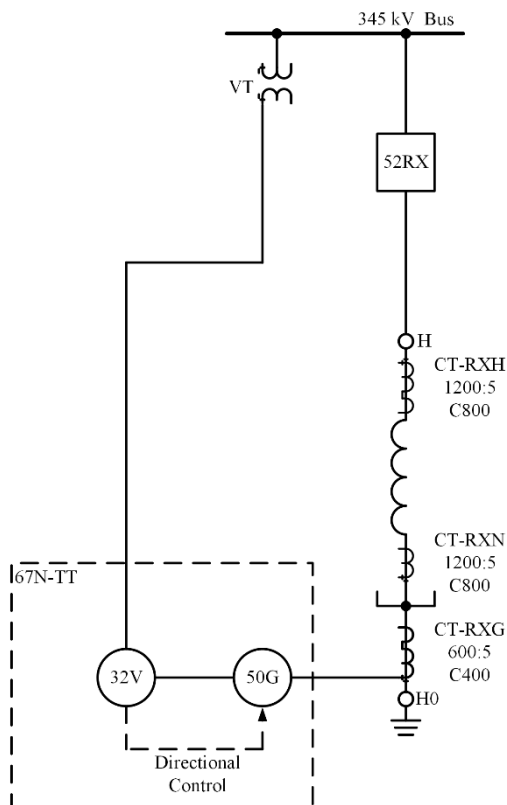

Fig. 7 67N turn-to-turn fault scheme.

This protection scheme allows for sensitive settings in the range of 5–15% of the reactor rating without compromising the security of the 87P element or putting excessive constraints on the reactor phase CTs used for 87P protection. Any unbalance currents in the reactor can be attributed to either system voltage unbalance or a turn-to-turn fault in the windings. An impedance-based zero-sequence polarized directional element with forward and reverse boundaries offset into the reactor can determine if the source of the imbalance is internal to the reactor or due to a ground unbalance on the transmission network [1] [7] [12].

The findings in [10], which showed that the autotransformer effect increased the sensitivity of the scheme to detect a turn-to-turn fault with a lower percent of shorted turns than the pickup setting, were useful information. It is not necessary to set the pickup at the very low end of the range to obtain good protection—especially in applications with a gapped iron-core.

The CT-RXG is wired polarity into the reactor, which follows the traditional practice of wiring CTs into the protected equipment. The restricted earth fault (REF) can also be used with the configuration; however, REF is not applied at Ameren. The reason for this decision is discussed in Section VI.F. The 67N element is directionally controlled by the zero-sequence directional element, which operates based on (3) [23]:

$$z_0 = \frac{\text{Re}\left(3V_0 \cdot [1\angle Z0\text{ANG} \cdot 3I_0]^*\right)}{|3I_0|^2} \quad (3)$$

where:

V_0 is the zero-sequence voltage.

I_0 is the zero-sequence current.

$Z0\text{ANG}$ is the zero-sequence impedance angle.

The forward and reverse thresholds are set per the guidance in [7] based on half the reactor impedance, but the CT is wired polarity into the reactor while an internal turn-to-turn fault will result in unbalance current that flows into non-polarity of the relay. To account for this, negative thresholds are used. The zero-sequence impedance directional elements are set per (4) and (5):

$$Z0F = \frac{-Z0_{\text{Reactor}}}{2} \quad (4)$$

$$Z0R = \frac{-Z0_{\text{Reactor}}}{2} + 0.1\Omega \quad (5)$$

$Z0\text{ANG}$ is set to the zero-sequence impedance angle per the reactor test report. If the user desires to wire the CT-RXG CT with polarity facing towards the ground connection, they would need to negate the thresholds in (4) and (5) and trip based on a forward directional decision.

The zero-sequence directional element set in this manner can distinguish between external faults and internal turn-to-turn faults as shown by examination of the sequence network for an external single-line-to-ground (SLG) fault per Fig. 8. For an SLG fault on the transmission system, the relay measures $-Z0_{\text{Reactor}}$ and the ground current flows up the neutral and into positive polarity of the relay, declaring a forward fault.

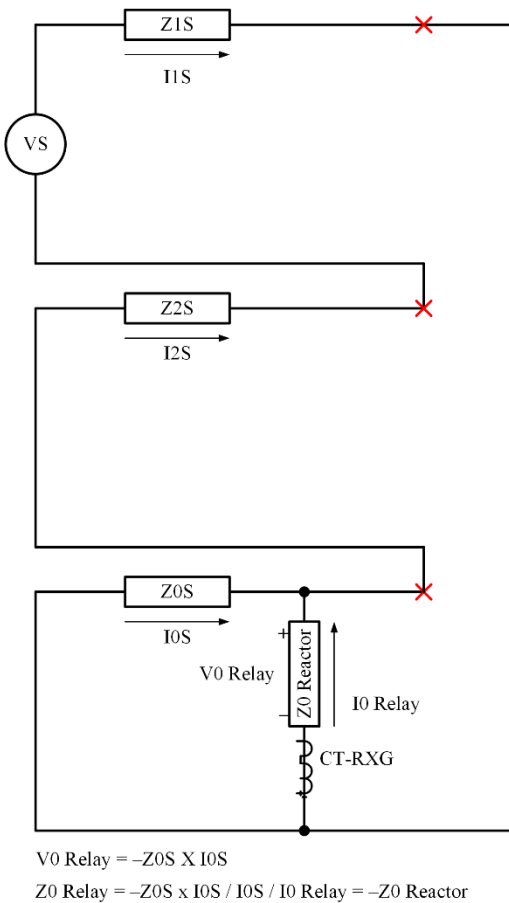

Fig. 8 External SLG fault sequence diagram.

For an internal turn-to-turn fault, the relay may measure close to 0 V of unbalance voltage (i.e., 3V0 in (2) equate to 0 V) and the ground current flows into non-polarity of the relay. As a result, the apparent $Z0$ will plot near the origin and a reverse fault is declared by the relay. The result is that system faults are forward and reactor turn-to-turn faults are reverse. Fig. 9 shows the zero-sequence directional impedance plot for a turn-to-turn and external SLG fault.

CT-RXG may be wired in series to the A, B, and C terminals of the X CT input such that it measures only zero-sequence current for use by the zero-sequence voltage-polarized impedance-based directional element. When connected this way, the effective CTR is the primary rating to 15 A (assuming a 5 A nominal CT) [12].

Ameren wires CT-RXG to only IB of the X CT input on the relay, resulting in false I1, I2 metered by the relay. This practice is accepted because Ameren has already done the same on other relaying packages that did not have a separate neutral current input. This is typical on generator step-up (GSU) transformer or autotransformer applications that have a grounded-wye CT installed on the H0 bushing. Wiring the CT to only the IB input on the relay is preferred so the settings match the prints, and this helps avoid a human performance issue where the engineer may misinterpret the CTR setting versus what the print shows.

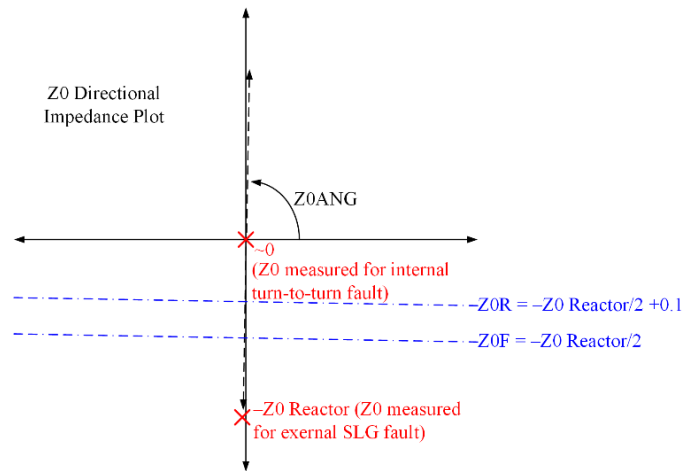

Fig. 9 Simplified $Z0$ directional impedance plot showing the approximate apparent impedance for an internal turn-to-turn fault and an external SLG fault.

In either case, there is a positive-sequence current restraint factor $I0/I1$ that supervises the 32V element. Typically, the $I0/I1$ supervision should be set above natural asymmetry of the system being protected [7]. However, per IEEE Standard C57.21 [24], the impedances of each phase of the reactor will be within $\pm 2\%$ of the average of the three-phase impedances. For reactors, the pickup is already set above the maximum 3I0 so this supervision is not needed. The pickup setting is unimportant given that the ratio will always be 1 if the CT-RXG is wired in once or infinity if it is wired in three times. Ameren sets it to minimum.

4) Pickup Considerations

As stated in the previous section, the 67N protection setting range is 5–15% of the reactor rating [2] to detect turn-to-turn faults. Ameren chose to enable three elements (67N1, 67N2, and 51N per [10]). However, these are directionally controlled by the 32V element as opposed to the 32Q element to eliminate the need to derive the unbalance current signal from the sum of three phase CTs. The reasoning for enabling them is discussed here.

The 67N1 element is set per [10] with a few differences and provides fast protection in case several turns short out rapidly. Reference [10] provides different setting guidance based on the reactor type. At Ameren, the 67N1 element is set independently of core type for simplicity and it is set to 50% of the reactor current with a delay of 1.5 cycles. This element is enabled so that tripping occurs rapidly if several turns have shorted or if a turn between windings shorts to another winding, which is more probable to occur in VSR applications discussed in Section VII.

The 67N2 element is set per [10] with a few differences and hits the desired sensitivity range of 5–15%. At Ameren, the pickup is chosen as 6% [10] because extensive simulations and field experience prove the security at a 6% pickup. At Ameren, the time delay is chosen as 10 cycles with an integrating timer [25] rather than using a short delay of 3 cycles per [10]. The time delay of 10 cycles is used per [1] to ride through normal transmission clearing (2-cycle trip time + 2-cycle breaker operate time + 6-cycle margin). Though the element will not pick up for a system fault due to being directionally controlled

with the 32V element, caution was used at Ameren. The 32V element is set to trigger an event report and if multiple events show the 32V element to remain secure after system fault clearing, a 3-cycle delay may be used as suggested by [10]. With a shorter 3-cycle delay, the integrating timer will likely no longer be used and using a shorter delay will help reduce the possibility of tank rupture.

The 51N element is set at 6% and shown to be secure during inrush simulations and field experience in [10]. The 67N2 element pickup was selected to match the 51N pickup for simplicity. Ameren sees value in applying the 51N element, which is supervised by the directional element, as a backup during energization and accepts that it would operate slowly to backup mechanical protection during energization. The guidance in [10] recommends this element be set so that it protects the reactor during energization when 67N2 element is disabled. In addition, the guidance from [10] recommends that only one 67N element is needed and is set at 6% with a 1.5-cycle delay for an air-core reactor application. At Ameren, the turn-to-turn fault protection is the same and is set independently of core type. Some reactors are liquid-immersed and lack a gapped iron-core; this information may be missing or overlooked when reviewing the nameplate. As a result, the core type may not be obvious to the setting engineer when a liquid-immersed reactor is used, and a setting error can be introduced. To avoid this, the turn-to-turn fault protection is set the same with the same supervisions for all reactor types.

5) CT Saturation Impacts on Protection

As with any protection system, the CTs may saturate for external faults, which can cause security issues for the scheme. For the application used in Fig. 5, the CT-RXG CT is a 600/5 C400 CT that is tapped down to 50/5. This severely derates the accuracy class to effectively a C33 CT. For convenience we repeat (1) here as (6), which can be used to evaluate to see if CT saturation is possible.

$$20 \geq \left(\frac{X}{R} + 1 \right) \cdot I_f \cdot Z_b \quad (6)$$

If the pu voltage required to be developed by the CT secondary to faithfully reproduce the primary current is greater than 20 pu, CT saturation is likely.

Data for an example installation to evaluate (6) are listed in Table III.

TABLE III
CT-RXG CONNECTED BURDEN AND FAULT DATA

Item	Data
Secondary CT resistance per turn (per data sheet)	0.0019 Ω
CTR	50/5
Effective accuracy class	C33
CT one-way cable impedance (1000 feet of 10 AWG cable, calculated per [17])	0.7 Ω
Relay burden	Assumed 0 Ω for simplicity
Z_b (2 • one-way cable impedance + CT resistance))	1.419 Ω
I_f (310 per fault study)	116 A
Zero-sequence X/R of reactor (per reactor test report)	301
Standard burden Calculated per [17]	0.33 Ω

If the saturation voltage is 20 times the voltage across the standard burden at rated current, then the CT will saturate. Using the data from Table III, the saturation voltage is calculated as (7):

$$20 \geq (301 + 1) \cdot \frac{116 \text{ A}}{50} \cdot \left(\frac{1.419 \Omega}{0.33 \Omega} \right) = 3,013 \quad (7)$$

The voltage required by CT-RXG CT for an external fault is alarmingly high. The CT data were entered into the spreadsheet created by PSRC [26] and the simulation results are shown in Fig. 10. The blue lines are ideal and the black lines are actual. The thin lines are the fundamental component extracted using a simple 1-cycle discrete Fourier transform. The X-axis is time in milliseconds and the Y-axis is magnitude in secondary amperes.

From the simulated data in Fig. 10, the saturated CT leads the ideal CT by about 75° maximum and the magnitude is attenuated to about 20%. Upon examination of (2) in Section C. The CT would generally need to have a phase lead greater than 90° before the directional element declares an incorrect decision. The adaptive threshold and attenuation are additional factors to maintain security of the directional decision, even with the poor performance expected with the CT tapped down this severely.

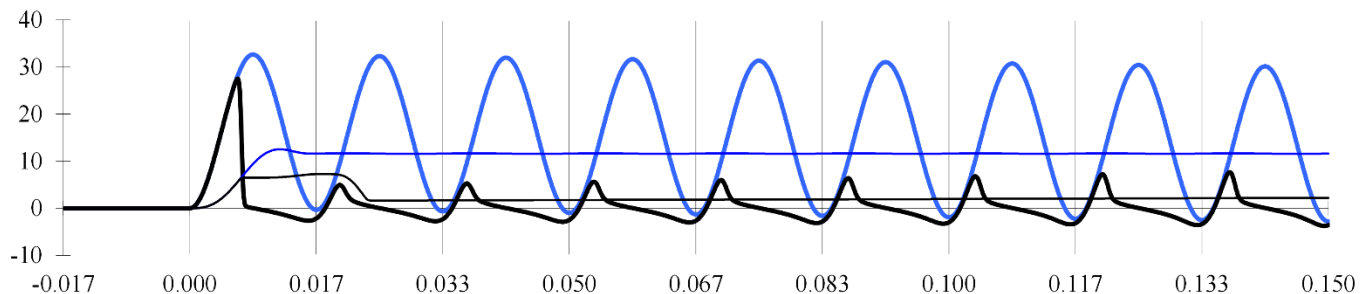

Fig. 10 Simulated CT response of the CT-RXG for an external fault.

For internal turn-to-turn faults within the reactor, the 3I0 measured current from CT-RXG may start out at a low value but could evolve into a heavy turn-to-turn fault, which may result in significant current from the autotransformer effect, however, with a sensitively set 6% pickup per Section C, it is expected that the turn-to-turn elements will operate.

We conclude that the accuracy class for CT-RXG may be a low rating, however on future projects a lower-primary rated CT may be used as an extra precaution.

6) *Miscellaneous Supervisions*

Magnetizing inrush can cause significant 3I0 to flow in the grounded-wye neutral CT of a gapped iron-core reactor due to unequal saturation of the iron-core. Many references exist on schemes that have been used to disarm the turn-to-turn fault protection during inrush and they can be found in [1] [8] [10] [20]. The 67N2 element is disabled during reactor energization using the inrush and external fault suppression logic presented in [10] with a modification to use a suppression delay of 5 time constants derived from the X/R of the reactor or 10 seconds, whichever is greater. The inrush suppression logic in [10] was preferred because it relies on currents and directional elements rather than voltages and breaker statuses that were used in [1]. Supervision of the 67N1 and 51N element during reactor energization is not required and has proven secure per [10]. For an air-core application, the suppression logic is not needed, however at Ameren it is always used as mentioned in the previous section.

When a transmission line is de-energized, a phenomenon occurs in which the distributed capacitance of the line exchanges energy with the line reactors and a step change in frequency can occur. The result is a decaying residual voltage on the line at an off-nominal frequency, which results in phasor estimation errors and can cause a misoperation of the turn-to-turn fault protection discussed in the previous section. Though this is primarily an issue with line-connected reactors, the frequency supervision logic from [10] is applied to the 67N elements to ensure security of the elements for abnormal switching.

Ameren's practice is that during loss-of-potential (LOP) conditions, there is protection available to detect all possible faults. The 67N1 and 67N2 elements are disabled to prevent misoperation during an external fault or during reactor energization concurrent with an LOP condition. The 51N element is enabled to be non-directional during LOP conditions to cover the case where mechanical protection is not available (e.g., the case for a dry-type reactor).

D. *63 Mechanical Protection Security*

Mechanical protection such as sudden pressure or Buchholz relaying is connected to the secondary reactor relay to trip. Mechanical type protection will respond to all tank faults; however, it is advised in reactor applications to detect turn-to-turn faults [2]. Mechanical protection may operate faster than electrical quantity-based protection to trip for a turn-to-turn fault to help prevent rupture of the reactor tank and fire. Likewise, electrical-based protection may operate faster than the mechanical type of protection. There are security concerns

for mechanical-based protection methods as applied to transformers and reactors and this is evident in reviewing trip and alarm practices in [27]. Some utilities may consider reactor protection similar to transformers and may make the mistake of alarming on mechanical-based protection for reactors. As discussed in Section V, reactor protection is different than transformer protection and mechanical protection is recommended for liquid-immersed reactors.

Reference [27] provides several possible causes of misoperation of mechanical protection, which include but are not limited to:

- Arcing across the 63 microswitch contact during voltage transients.
- Moisture-related corrosion on the microswitch contacts.
- Operation due to shaking of transformer windings during a through fault.

The first two security concerns are mitigated by using proper dc control circuit design as described in [27]. Ameren uses an auxiliary seal-in relay (63GX in Fig. 5) similar to Figure A-7 of [27]. If there is not an auxiliary seal-in relay available in the apparatus cabinet during a reactor relay protection upgrade, custom logic is used in the microprocessor relays to implement the same functionality as an auxiliary seal-in relay and the logic is similar to that in [28]. The third bullet is of no concern for reactors because through faults on reactors are on the order of 1.0 pu and, because the windings are braced for this current, it is not expected that the windings would shake enough to cause pressure waves in the oil.

Ameren prefers to use Buchholz relaying when possible due to better operating experience when compared to sudden pressure relaying that is applied under oil. Buchholz relays will also trip for low oil conditions, so a separate low oil relay is not needed. In at least one reactor application at Ameren, Buchholz and sudden pressure relaying is connected to trip. When Buchholz relaying is used, care should be taken to ensure that the gas accumulation contacts are not mistakenly used to trip the reactor because this is not necessarily indicative of a fault.

E. *Summary of Ameren's Turn-to-Turn Protection*

Ameren's turn-to-turn fault protection settings are summarized in Table IV and Table V.

Examination of Fig. 5 shows that while the 67N function is implemented in both relays, a single neutral ground CT provides the operating signal to both relays. The lack of redundant CTs for this function is deemed acceptable given that we apply mechanical protection to obtain redundancy for turn-to-turn faults. In dry-type applications where mechanical protection is not possible, installing two neutral ground CTs is recommended.

TABLE IV
67N TURN-TO-TURN FAULT PROTECTION ELEMENTS

Element	Setting Criteria	Armed During Energization?
67N1	50% of reactor rating with 1.5 cycle delay	Y
67N2	6% of reactor rating with 10 cycle delay via an integrating timer	N
51N	6% of reactor rating, curve shape of U2 and time dial of 2.5	Y
63	Input from the 63GX wired to an input and set to trip	Y

TABLE V
32V ZERO-SEQUENCE IMPEDANCE DIRECTIONAL ELEMENT
SETTING CRITERIA

Setting	Setting Criteria
Z0F (forward threshold)	$-Z_0 \text{ Reactor}/2$
Z0R (reverse threshold)	$Z_0F + 0.1$
I0/I1 (positive-sequence restraint factor)	0.02 (set to minimum)
32VSUP (32V minimum 3V0 supervision)	0 V

F. Why REF Protection is Not Necessary for Shunt Reactors

We do not advocate applying REF protection on a shunt reactor. REF is recommended for transformer applications because it takes advantage of the high current circulating in the neutral CT for a winding to ground fault. A reactor includes an 87 KCL element that measures the current in the CTs at the neutral end of the reactor winding, so it has the same advantage as an REF element to detect winding to ground faults near the neutral. This is the same principle as what is called phase segregated REF for banks of three single-phase transformers in [12].

VII. VARIABLE SHUNT REACTOR CONSIDERATIONS

VSRs have an on-load tap changer (OLTC) that is used to adjust the reactance as much as two times its base rating [24]. Ameren's present standard is to purchase a 345 kV variable 50–100 MVAR shunt reactor if system planning specifies a VSR for the application. The reactors are switched on at the lowest rating to reduce the shock to the system. A voltage schedule set point is provided to a primary OLTC controller that will then issue raise/lower commands to the OLTC motor to adjust the reactance. The OLTC has a secondary OLTC controller that is available if the primary controller has failed.

The VSR that is in-service at Ameren has three windings per phase. A main, coarse, and fine winding are all wound concentrically around each leg of the gapped iron-core and separated by insulation. The OLTC adjusts the reactances of the coarse and fine windings to achieve the desired reactance.

The types of faults that occur within the VSR tank are the same as a static shunt reactor, however there is an additional type of turn-to-turn fault that can occur. The physical proximity of the main and coarse winding is such that a turn-to-turn fault could occur between these windings and several turns could be shorted out rapidly. In addition, the fine and coarse windings are in physical proximity to each other and a turn-to-turn fault can occur between these windings. The 67N1 element discussed in Section VI will detect these types of faults rapidly.

VSR protection is set similarly to static shunt reactors, but with the following differences:

1. Breaker failure current detectors will be set based on the lowest MVA rating (at least 75% of rated current).
2. The 87P pickup will be set to 0.5 pu based on the highest MVA rating for security. Note that at the lower rating, an 87P set in this manner will essentially be 1.0 pu when the VSR is operating at its lowest rating.
3. 67N1 is set to 50% of rated current based on the highest MVA rating [10].
4. 67N2 and 51N is set to 6% rated current based on the highest MVA rating [10].
5. 67N1 timer is set to 2.5 cycles [10].
6. 67N2 timer's 10-cycle delay should not be reduced due to possible non-simultaneity of mechanical OLTC contact operation in each phase.
7. Z0F/Z0R thresholds should be set based on the lowest reactor impedance (applicable while the VSR is operating at its highest MVA).

VIII. CONCLUSION

EHV shunt reactor protection has received more attention in the industry in recent years. A decade ago, there were very few technical papers on the subject to draw from. The new C37.109-2023, IEEE Guide for the Protection of Shunt Reactors, is a significant improvement over the superseded version. Ameren used this guide and many other references to gain a better understanding of reactor characteristics and protection practices to develop a new protection standard.

Recent improvements in multifunction protective relays have greatly simplified transmission-connected shunt reactor protection. A key feature that enables one multirestraint transformer relay to perform all electrical protective functions is that the zero-sequence impedance-based directional element can now have the minimum 3V0 supervision removed to allow implementation of the sensitive turn-to-turn fault protection scheme using only current signals from the neutral ground CT. Ameren applies two of these relays for full redundancy of all electrical protection. Prior to this improvement, a separate directional relay was required to implement the sensitive turn-to-turn fault scheme.

The new standard greatly simplifies the task of CT selection. By using a multifunction transformer relay with enough individual CT inputs and separating the protective elements for faults between the breaker and the reactor, faults internal to the reactor, and reactor turn-to-turn faults, the CTs supplying signals to each protective element can be optimized for the

requirements of each type of fault. The need for detailed analysis to evaluate and select CTRs with significant compromises is practically eliminated. The relaxed CT requirements for the reactor phase CTs used by the differential protection, coupled with the presented guidelines for setting the minimum pickup, effectively mitigate the number one security concern for reactor differential protection. Mis-operation on false differential due to unequal CT performance during switching is no longer a credible concern.

The new standard simplifies primary equipment configuration as well. Separating the protection functions enabled Ameren to specify reactor breakers with standard CTs. This allows Ameren's spare breakers to be adapted for reactor breaker replacement by simply adding a POW controller. It also eliminates the human performance concerns with ensuring that the reactor breaker is installed with the correct orientation.

Finally, Ameren analyzed requirements to reliably detect the various faults in the reactor zone and was able to greatly simplify the protection by eliminating elements that only complicate application while adding little value. Only four key elements are used: 50P for system level faults, 87P for reactor internal faults, 67N for electrical detection of turn-to-turn faults, and 63 (sudden-pressure/Buchholz) for mechanical detection of turn-to-turn faults. Two relays are used for redundancy.

The authors hope that this paper provides a ready reference on how to implement the best ideas presented in the new C37.109 for solidly grounded shunt reactors. Ameren's new reactor protection standard greatly simplifies the primary equipment requirements and protection configuration and uses the full capabilities of the standard transformer differential relay that Ameren uses on their transmission system transformers.

IX. REFERENCES

- [1] F. K. Basha and M. Thompson, "Practical EHV Reactor Protection," proceedings of the 66th Annual Conference for Protective Relay Engineers, College Station, TX, April 2013.
- [2] IEEE Standard C37.109-2023, IEEE Guide for Protection of Shunt Reactors.
- [3] Z. Gajic, B. Hillstrom, and F. Mekic, "HV Shunt Reactor Secrets for Protective Engineers," proceedings of the 30th Annual Western Protective Relay Conference, Spokane, WA, October 2003.
- [4] D. Goldsworthy, T. Roseburg, D. Tziouvaras, and J. Pope, "Controlled Switching of HVAC Circuit Breakers: Application Examples and Benefits," proceedings of the 34th Annual Western Protective Relay Conference, Spokane, WA, October 2007.
- [5] F. Bassi, G. Ramundo, A. D. Tomasso, Y.Z. Korkmaz, and M. Donolo, "Case Study: How CT Saturation Due to Incorrect Point-on-Wave Switching Affects Shunt Reactor Differential Protection," proceedings of the 47th Annual Western Protective Relay Conference, Virtual Format, October 2020.
- [6] SEL-487E Transformer Protection Relay Instruction Manual. Available: selinc.com
- [7] R. McDaniel and M. Thompson, "Impedance-Based Directional Elements – Why Have a Threshold Setting?" proceedings of the 48th Annual Western Protective Relay Conference, Spokane, WA, October 2021.
- [8] CIGRE WG B5.37 Report, "Protection, Monitoring and Control of Shunt Reactors," August 2013.
- [9] Y. Xue and M. Thakur, "CREZ Line Protection Design: Challenges and Solutions," proceedings of the 39th Annual Western Protective Relay Conference, Spokane, WA, October 2012.
- [10] R. Chowdhury, N. Fischer, D. Taylor, D. Caverly, and A. B. Dehkordi, "A Fresh Look at Practical Shunt Reactor Protection," proceedings of the 49th Annual Western Protective Relay Conference, Spokane, WA, October 2022.
- [11] B. Kasztenny, M. Thompson, and N. Fischer, "Fundamentals of Short-Circuit Protection for Transformers," proceedings of the 2010 63rd Annual Conference for Protective Relay Engineers, College Station, TX, March–April 2010.
- [12] J. Hostetler, M. Thompson, and A. Hargrave, "Useful Applications for Differential Relays With Both KCL and ATB 87 Elements," proceedings of the 77th Annual Conference for Protective Relay Engineers, College Station, TX, March 2024.
- [13] B. Kasztenny, M. J. Thompson, and D. Taylor, "Time-Domain Elements Optimize the Security and Performance of Transformer Protection," proceedings of the 71st Annual Conference for Protective Relay Engineers, College Station, TX, March 2018.
- [14] M. J. Thompson, "Percentage Restrained Differential, Percentage of What?," proceedings of the 64th Annual Conference for Protective Relay Engineers, College Station, TX, April 2011.
- [15] S. E. Zocholl and D. W. Smaha, "Current Transformer Concepts," proceedings of the 46th Annual Georgia Tech Protective Relaying Conference, Atlanta, GA, April 1992.
- [16] M. Thompson, R. Folkers, and A. Sinclair, "Secure Application of Transformer Differential Relays for Bus Protection," proceedings of the 58th Annual Conference for Protective Relay Engineers, College Station, TX, May 2005.
- [17] G. Benmouyal, J. Roberts, and S. E. Zocholl, "Selecting CTs to Optimize Relay Performance," proceedings of the 1996 Pennsylvania Electric Association Relay Committee Fall Meeting, September 1996.
- [18] B. Kasztenny, N. Fischer, D. Taylor, T. Prakash, and J. Jalli, "Do CTs Like DC? Performance of Current Transformers With Geomagnetically Induced Currents," proceedings of the 69th Annual Conference for Protective Relay Engineers, College Station, TX, April 2016.
- [19] A. Hargrave, M. J. Thompson, and B. Heilman, "Beyond the Knee Point: A Practical Guide to CT Saturation," proceedings of the 71st Annual Conference for Protective Relay Engineers, College Station, TX, March 2018.
- [20] M. Selak, R. Barone, and A. Elnewehi, "BC Hydro Applications for 500kV Shunt Reactors." Available: https://wprcarchives.org/wp-content/uploads/2024/07/Meliha-B.-Selak_BC-Hydro-Protection-Applications-for-500-kV-Shunt-Reactors_2008.pdf.
- [21] "Setting Considerations for Low Impedance Differential Protection in Shunt Reactor Applications and Proposal of an Alternative Protection," Cvorovic, Troedsson, & Roxenberg Study Committee B5 Colloquium, August 25–31, 2013, Belo Horizonte, Brazil.
- [22] S. Uddin, A. Bapary, M. Thompson, R. McDaniel, and K. Salunkhe, "Application Considerations for Protecting Transformers With Dual Breaker Terminals," proceedings of the 45th Annual Western Protective Relay Conference, Spokane, WA, October 2018.
- [23] A. Guzmán, J. Roberts, and D. Hou, "New Ground Directional Elements Operate Reliably for Changing System Conditions," proceedings of the 23rd Annual Western Protective Relay Conference, Spokane, WA, October 1996.
- [24] IEEE Standard C57.21-2021, *Requirements, Terminology, and Test Code for Shunt Reactors Rated Over 500 kVA*.
- [25] M. Thompson, "Implementing Memory Register Functions Using Advanced SELLogic Control Equation Math Functions in SEL-400 Series Relays," SEL Application Guide (AG2010-17), 2010. Available: <https://selinc.com/api/download/8789/>.
- [26] IEEE Power and Energy Society Power System Relaying and Control Committee, CT SAT Calculator – Spreadsheet. Available: <https://www.pes-psrc.org/reports>.

- [27] IEEE Power and Energy Society Power System Relaying Committee – K6 Working Group Report, “Sudden Pressure Protection for Transformers,” December 2014. Available: <https://www.pes-psrc.org/reports>.
- [28] D. Costello, “Using SELOGIC® Control Equations to Replace a Sudden Pressure Auxiliary Relay,” SEL Application Guide (AG97-06), 1997. Available: <https://selinc.com/api/download/5067/>.

X. BIOGRAPHIES

Michael J. Thompson received his B.S., magna cum laude, from Bradley University in 1981 and an M.B.A. from Eastern Illinois University in 1991. Upon graduating, he served nearly 15 years at Central Illinois Public Service (now Ameren). Prior to joining Schweitzer Engineering Laboratories, Inc. (SEL) in 2001, he worked at Basler Electric. He is presently a Distinguished Engineer at SEL Engineering Services, Inc. He is an IEEE Fellow, Past Chair of the IEEE PES Power System Relaying and Control Committee, past Chair of the PSRC Substation Protection Subcommittee and received the Standards Medallion from the IEEE Standards Association. He also served as a subject matter expert advising the System Protection and Control Working Group of the North American Electric Reliability Corporation for many years. Michael is a registered professional engineer in six jurisdictions, was a contributor to the reference book, *Modern Solutions for the Protection Control and Monitoring of Electric Power Systems*, has published numerous technical papers and magazine articles, and holds four patents associated with power system protection and control.

Steve Mueller received his B.S., summa cum laude, from the University of Missouri–St. Louis in 2012. Upon graduating, he joined Schweitzer Engineering Laboratories, Inc. (SEL) for four years and presently serves at Ameren as a system protection engineer. He is an active and contributing member of IEEE PES Power System Relaying and Control Committee and is presently serving on the NERC PRC-019-3 Standard drafting team. He is the recipient of the 2021 Ameren President’s individual excellence award and the 2021 Ameren President’s team excellence award.