

# Advancements in Relay Contact Output Self-Testing and Trip Circuit Monitoring Capabilities

Austin Wade, David Schmidt, Brandon Nafsinger, and Jordan Bell  
*Schweitzer Engineering Laboratories, Inc.*

Presented at the  
51st Annual Western Protective Relay Conference  
Spokane, Washington  
October 22–24, 2024

Originally presented at the  
77th Annual Conference for Protective Relay Engineers at Texas A&M, March 2024

# Advancements in Relay Contact Output Self-Testing and Trip Circuit Monitoring Capabilities

Austin Wade, David Schmidt, Brandon Nafsinger, and Jordan Bell, *Schweitzer Engineering Laboratories, Inc.*

**Abstract**—This paper presents a novel algorithm for trip circuit monitoring using output contacts with integrated current and voltage measurements. The algorithm validates output contact closure and discriminates output contact failure from other problems in the direct current (dc) circuit, closing one of the last gaps of relay self-testing capabilities.

The output contacts employ an anisotropic magneto resistance current sensor that provides high-accuracy dc current measurements over a wide range, while also providing the ability to reject common-mode magnetic fields, which can affect other dc current sensor technologies when measuring low-level currents. The contacts also include a voltage sensor, which provides an analog measurement and a binary status that mimics a traditional binary input wired across a trip contact. Both current and voltage measurements are captured at 10 kHz and are provided to the algorithm at 1 kHz.

The algorithm can be used to flag successful, failed, or indeterminate output contact operations. Event records from laboratory testing show how output contact operation can be accurately determined, even in applications with parallel trip paths or in situations with sequential tripping, potentially reducing or eliminating the need for periodic manual maintenance. The paper also covers applications in which the algorithm can be used for verification of dc circuits to assist with NERC PRC-005 compliance, the detection of circuit failures missed by traditional monitoring methods, and the characterization of circuit and coil performance for condition-based monitoring. Finally, the paper explores how enhanced contact monitoring can be used in breaker failure schemes.

## I. INTRODUCTION

Breaker trip circuits consist of a direct current (dc) supply, relay contact outputs, a breaker trip coil (TC), and associated wiring. These circuits may be called to operate in milliseconds after months or years of sitting idle. The failure or degradation of any one of these components can result in a failure to trip the circuit breaker during a system fault, thereby extending fault duration, increasing the outage zone (when backup protection clears the fault), and potentially causing system instability, equipment damage, or hazards to the public and personnel. Because of the critical function of the trip circuit, trip circuit monitoring (TCM) schemes (also referred to as trip circuit supervision schemes) are often employed. TCM schemes have been implemented for decades with the goals of detecting failures as early as possible and providing alarms to system operators.

Early TCM schemes were as simple as wiring an indication lamp across the trip bus or in parallel with the trip contacts. The illumination of the lamp indicated to operators that the breaker was closed with the trip circuit intact and control voltage present. If the lamp was not illuminated, they knew a problem

existed; the problem could be a burned-out bulb, loss of dc control power, shorted trip circuit, or an open circuit. Later, discrete TCM relays were developed to mimic the indication lamp functionality with auxiliary contacts for supervisory control and data acquisition (SCADA) or annunciator monitoring.

In many electromechanical relays, the target is actuated by the current flowing through the trip contact, essentially proving that the relay trip contact operated. This feature provides an additional level of assurance regarding the trip circuit operation.

As microprocessor-based digital relays became more popular and prevalent, the TCM functionality started to be integrated into the relay using internal logic with binary inputs on the trip bus and connected to the 52b contact, as shown in Fig. 1 [1].

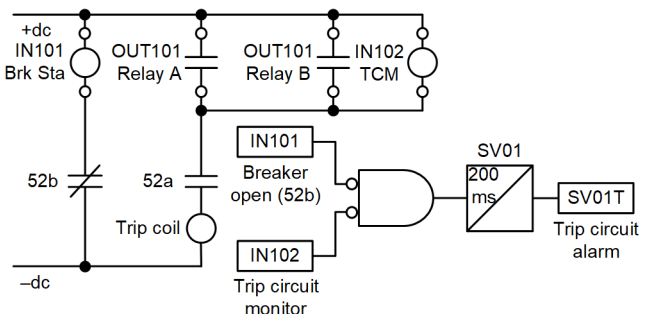

Fig. 1 Typical TCM Connections

These methods of TCM helped detect the same failures: loss of supply, loose or open connections, and failed TCs. However, modern microprocessor-based relays lack the capability of monitoring the correct operation of their trip contacts, leaving a gap in self-testing and monitoring.

Modern protection systems often employ redundancy for critical applications to ensure their protection scheme operates as intended. This may include redundant relays, multiple TCs, and dc supplies. In addition, microprocessor-based relays provide ways for the relay and protection system to test themselves [1]. Even with the self-testing possible in modern protection and control systems, the monitoring and self-testing of relay output contacts are relegated to periodic function testing performed by maintenance personnel [2].

This paper introduces a new protective relay output contact that allows the relay to record and measure voltage across and current flowing through the contact. It then provides a novel algorithm that allows the relay to verify the proper operation of the output contact.

## II. A GAP IN PROTECTION SYSTEM SELF-TESTING

Microprocessor-based relays introduced a transformative shift in how protection systems are designed and tested. The microprocessor-based relay self-testing capabilities have replaced or substantially reduced the annual tests required by electromechanical relays. Reference [3] scrutinized field return data from over 3,300 protective relays and assessed that self-tests could identify 75.1 percent of relay failures. The remaining failures, undetectable by self-tests, are delineated in Table I.

TABLE I  
DISTRIBUTION OF FAILURES NOT DETECTED BY SELF-TESTING

Failure category	Percentage not detected
Human-machine interface (HMI)	36
Inputs/outputs (I/O)	24
Analog inputs	19
Communications	16
Other	5

It becomes evident that most failure categories can be monitored externally from the relay through an integrated system monitoring approach. References [1] and [4] argue that modern protective relays offer more than just internal self-testing capabilities. When thoughtfully designed and integrated, these relays can contribute to a comprehensive protection, control, and monitoring system that can test and monitor itself. It is worth noting that HMI failures can be excluded from discussions concerning the overall reliability of the protection system, as they do not impinge upon successful operation.

This leaves I/O failures at 37.5 percent of non-HMI failures that cannot be detected by relay self-testing, showing that output verification is one of the last gaps of a fully self-testing system.

### A. Reliable, Robust, and Fast Contact Outputs

Contact outputs are one of the most important components of protective relays. Like breakers, outputs may sit idle for months or years without operation and then be called to operate in a few milliseconds. The critical role of contact outputs has driven the industry to develop various output hardware topologies and logic schemes to increase reliability, durability, and speed.

To ensure that relay contact outputs are suited to energize TCs, [5] dictates that tripping contacts are rated and tested to make and carry 30 A for 200 ms and at least 2,000 operations. However, interrupting ratings are not specified because tripping circuits typically rely on breaker auxiliary contacts for current interruption to protect the internal relay contacts. To facilitate this external interruption, digital relays employ various methods, such as:

- A minimum trip duration timer. This approach delays the relay contact opening for longer than the typical breaker operating time, allowing the breaker auxiliary contact to interrupt the current first.

- 52a seal-in logic. This method assumes that if the 52a contact wired to the relay opens, then the 52a contact in the trip circuit has also opened, which interrupts the dc current.
- Primary current seal-in logic. Like the 52a logic, this approach relies on the cleared primary current and implies that the breaker tripped and, consequently, that the 52a contact opened, which interrupts the dc current.
- Trip current seal-in logic. This method directly monitors the dc current flowing in the output contact. This strategy emulates the old target and seal-in auxiliary relay but uses digital logic to seal in the output contact until the auxiliary contact interrupts the current. This method requires some indication or measurement of current through the contact output [2].

Hybrid output contacts were introduced to enhance the robustness and speed of tripping contacts. Hybrid contacts, also known as high-speed, high-current (HSHC) output contacts, combine the benefits of both electromechanical (metallic) contacts and solid-state technologies. Metallic contacts offer low-resistance and high-current-carrying capacity but operate in the millisecond range and cannot break significant current. On the other hand, solid-state circuitry can initiate tripping in microseconds but have limited capability to carry current for an extended duration. Furthermore, the solid-state transistor excels at breaking higher current. In operation, the two types of contacts work in tandem as follows:

- Contact closing—the relay triggers a contact closure, and both the metallic and solid-state transistors initiate closure simultaneously. The solid-state transistor establishes a path for current flow within microseconds, while the metallic contact physically takes milliseconds to close. Once the metallic contact is closed in parallel with the solid-state transistor, most current flows through the low-resistance path of the metallic contact. These contacts may bounce, causing fluctuations in current flow through contacts and transistors. Shortly afterward, the solid-state transistor is allowed to open.
- Contact opening—the relay triggers a contact opening, and the solid-state contact is quickly switched closed in parallel with the metallic contacts. The metallic contact is then permitted to open. During the metallic contact opening, current continues to flow through the transistor until the contacts part sufficiently enough to establish adequate dielectric strength. At this point, the transistor turns off, and any stored energy is dissipated through a metal-oxide varistor, preventing arcing on the metallic contacts.

### B. Is It Time to Close This Gap?

Despite efforts to ensure tripping contacts are robust and reliable, there is presently no integrated solution to self-test output contacts or have assurance that they operated correctly. To verify correct output operation requires personnel to perform manual inspection and testing. Testing is often

completed during a predetermined maintenance interval with very few findings, costing many man-hours in the process to perform.

Moreover, such practices may introduce negative consequences: reduced equipment availability, increased risk of human error, and strained operation and maintenance (O&M) resources, leading to a higher total cost of ownership, potential equipment damage, and unforeseen complications [6].

The need is clear: a self-monitoring protective relay tripping output contact capable of identifying and reporting potential problems and failures.

### III. NEW TRIP CONTACT WITH COMPREHENSIVE MONITORING

Advancements in electric vehicles, chargers, and bulk battery storage have driven the need for the high-accuracy measurement of dc currents. Additionally, processing power continues to increase in nearly every electronic device, from computers to embedded electronics, including digital protective relays. These market evolutions now make it viable to include multiple output contacts that have additional measurement and monitoring capabilities in every protective relay.

The output contact presented in this paper uses a proven HSHC Form A output contact that incorporates a voltage measurement across the contact and a current measurement through the contact, as shown in Fig. 2, for comprehensive monitoring (CM).

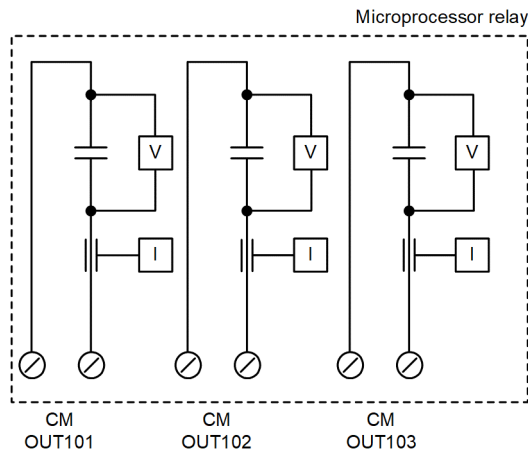

Fig. 2 Relay Output Contacts With V and I Measurements

The CM output contacts employ an anisotropic magneto resistance current sensor that provides high accuracy over a wide range of dc current measurements, while also providing electrical isolation and the ability to reject common-mode magnetic fields, which can affect low-level measurements [7]. Current measurements have an operational range of 0.25 to 20.0 Adc with a resolution of  $\leq 0.1$  A. The CM output adheres to IEEE C37.90 and provides up to 30 A make. Above the operational range of 20 A, the measurement is clipped. This may occur on oil circuit breakers in which individual TCs for each pole are wired and energized in parallel to three-pole trip. Voltage measurements have an operational range of 38 to 300 Vdc with a resolution of  $\pm 2$  Vdc. Both current and voltage measurements are sampled at 10 kHz and then downsampled to 1 kHz to be used in firmware and custom user logic. The 10 kHz

and 1 kHz streams are recorded and available in COMTRADE format.

#### A. Simplified TCM and Close Coil Monitoring (CCM)

The voltage sensor in the CM output also provides a binary status by using standard voltage thresholds that mimic a traditional binary input wired across a trip contact. The relay can use these binary data for integrated traditional TCMs and CCMs or breaker position indications.

When both trip and close outputs are implemented with CM contacts, a low-wiring, simplified TCM and CCM and a breaker status scheme can be implemented, as shown in Fig. 3. The trip circuit has a 52a contact in series with the TC. This contact is primarily used to interrupt the dc current when the breaker opens but can also be used for position indication. When the breaker is closed, voltage monitoring across the trip contact (OUT101.CrctMon\_Sta) indicates the breaker-closed status and the health of the trip circuit. Similarly, the close circuit has a 52b contact in series with the close coil (CC). When the breaker is open, voltage monitoring across the close contact (OUT102.CrctMon\_Sta) indicates the breaker-closed status and the health of the close circuit.

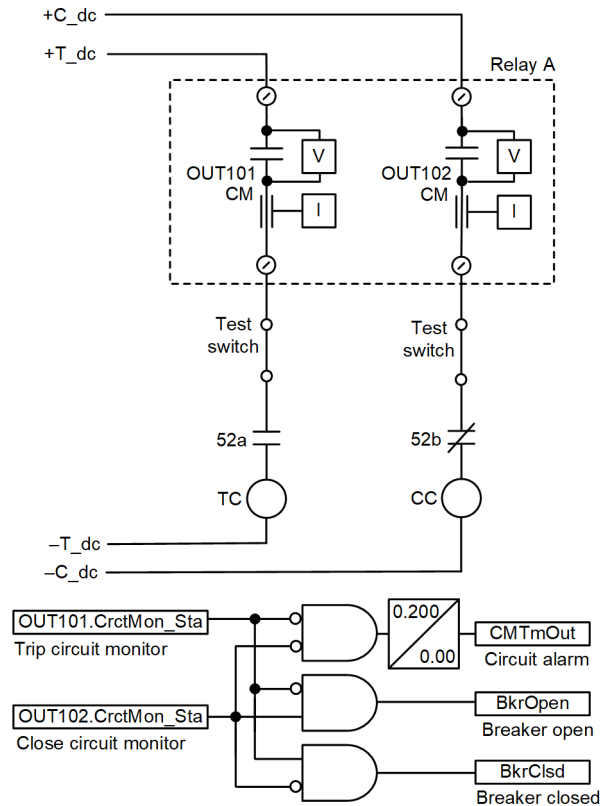

Fig. 3 TC and CC Wired With CM Outputs

There are numerous ways to implement traditional TCM and CCM schemes, and engineers have their own practices and preferences. Fig. 3 represents a low-wiring option for cases in which auxiliary contacts are not available, there are no spare binary inputs on the relay, or the user does not want to add wiring. However, because of its simplicity, the scheme shown in Fig. 3 does not provide all the features of a more complex scheme. Specifically:

- Because the breaker 52a/b contacts are in series with the coils (logical ANDs), it alarms for a problem in either the trip or close circuit, and once an alarm is received, field investigation (verification of red and green indicating lights, etc.) is required to confirm which circuit is problematic.
- An open trip circuit with the breaker closed or an open-close circuit with the breaker open results in a loss of breaker position indication.
- During a close operation, OUT102.CrcMon\_Sta drops out when the contact closes and then reasserts momentarily after the contact opens, while voltage is still measured across the antipump relay (before the charging cycle completes and breaks the circuit).
- The TC is not monitored when the breaker is open. (It is evident this feature requires modification to the breaker cabinet wiring to implement a 52b contact wired in series with the TC.)
- It does not alarm for a total loss-of-control voltage on the trip circuit when the breaker is open or a loss of close voltage when the breaker is closed.

The scheme shown in Fig. 3 can be augmented by adding separately wired 52a/b contact input statuses (this addresses the bullet points 1, 2, and 3) or contact inputs wired across the dc supply voltage (this addresses the bullet point 5), while still eliminating the need for separate inputs wired across the trip and close outputs for TCM and CCM.

The simplification of TCM and CCM schemes using CM outputs facilitates the integration of that functionality into each protective relay on a trip bus, thereby providing more granular alarming for other issues. Fig. 4 shows a simplified schematic of two relays wired in parallel to trip TC1 with the test switch on Relay B open. If only Relay A includes the CM output and TCM logic, the open test switch might go unnoticed. If only Relay B includes the CM output and TCM logic, an operator might assume there is a problem in the breaker. With both relays utilizing CM outputs and integrated TCM logic, the alarm from Relay B coupled with the lack of alarm from Relay A indicates a problem just with the Relay B parallel portion of the trip circuit.

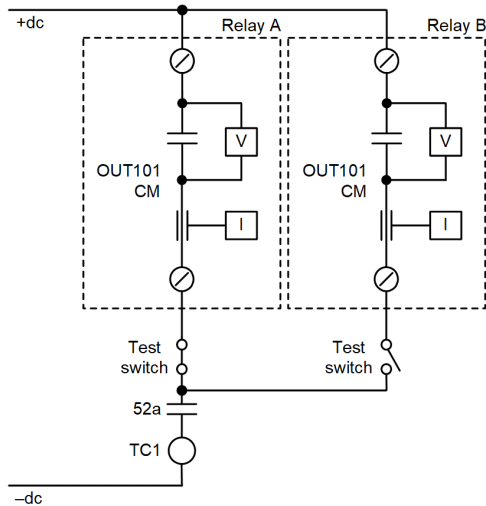

Fig. 4 Two Relays Tripping TC1 With Relay B Test Switch Left Open

Another important distinction of the CM output and the integrated voltage monitoring approach to TCM and CCM is the leakage current compared to traditional contact inputs. For example, contact inputs on a popular line relay have a current draw of up to 5 mA [8]. While this does not often affect trip circuits, it can lead to issues on close circuits, in which the leakage current can cause the antipump relay to operate or seal in. This effect is compounded if multiple devices are performing parallel monitoring on the same circuit. The CM output negates these issues because it does not require the same magnitude of burnishing current as traditional contact inputs. The CM output has a leakage current of approximately 350  $\mu$ A, reducing the concern of utilizing parallel monitoring devices.

#### B. What Else Does the Current and Voltage Tell Us?

Monitoring and recording the current and voltage for trip and close circuits provide us with a simple and granular way to look at protection systems that previously took additional special equipment. Using these data, we can look at several failure modes and alert for abnormal conditions, such as off-nominal voltages, excessive current flow, or attempts to interrupt excess current. With the combination of current and voltage, we can determine contact operation, coil health, and breaker health. But before we discuss how the new algorithm uses these data to determine contact operation, let us first review TC current profiles.

#### IV. TC CURRENT PROFILES

The role of the trip circuit is to transfer the relay trip decision to the breaker. In terms of energy transformation, the function of the TC is to change electrical energy into magnetic energy, and subsequently, the plunger movement of the coil transforms the magnetic energy into mechanical energy.

Researchers, including those referred to in [9] [10] [11], have found that during this process of converting electrical energy into mechanical energy, the electromechanical characteristics of the trip circuit, TC, and breaker mechanism are captured in the electric current through the trip circuit. Additionally, they found that this current captured a unique current and time profile or trip signature that is very consistent for an individual breaker and that deviations from the expected signature are indicative of specific failures in the trip circuit and breaker mechanism.

Researchers have explored ways to analyze and characterize the current profile to identify possible issues with the trip circuit and breaker. However, one persisting issue is the variability in TC current profiles, depending on the breaker's manufacturer and mechanism design.

#### A. Trip Current Profile Common Regions

Despite the variability in different breakers, we can identify generic similarities among the trip current profiles, which help us develop and define our algorithm in the following sections. Fig. 5 shows a measured trip current profile of a 145 kV SF6 breaker that has been divided into four distinct regions.

1. Trip contact closure and current rise—the relay closes the trip contact, and current starts flowing through the circuit. The current rise is limited by the circuit and electrical characteristics of the coil.
2. Plunger movement—once the current in the TC reaches a value high enough to cause a large electromotive force (EMF) that overcomes the reset spring, the plunger starts to accelerate. This metallic plunger then generates a back EMF, due to Lenz's law of electromagnetic induction.
3. Postplunger movement—after the plunger hits the trip latch on the breaker, it stops moving because it has reached its maximum travel distance. This results in a reduction of the back EMF on the TC, allowing the current to start rising again based on the L/R characteristics of the coil. The current increases until it reaches its maximum value, determined by the voltage applied to the TC and the resistance of the coil.
4. Breaker contact operation and current decay. Once the trip latch actuates, the stored energy in the breaker causes the mechanical assembly to operate, tripping open the power contacts of the circuit breaker and leading to a change of state of the auxiliary breaker contacts. One of the 52a auxiliary contacts opens, breaking the continuity of the trip circuit and allowing the coil current to decay from its maximum value to zero, again as a function of the L/R characteristics of the coil [9].

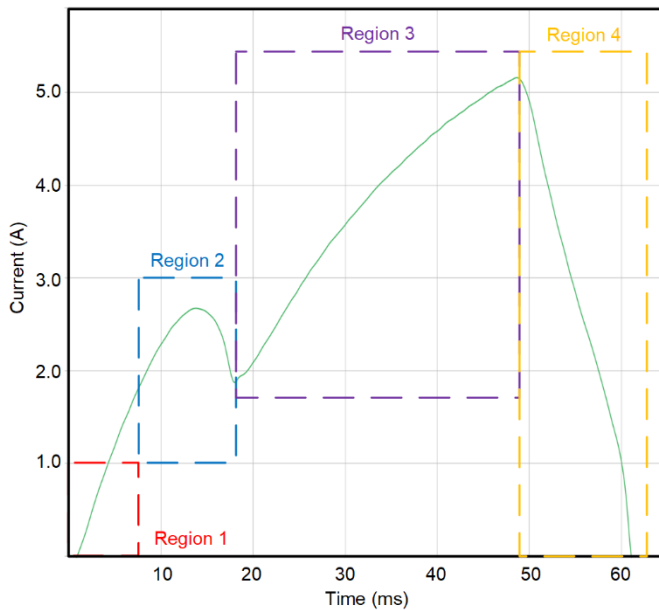

Fig. 5 Current Profile for TC

### B. Consistency in Current Profile

With the current profile discussed and the four operating regions identified, exactly how consistent is this current profile over the life of a breaker? Fig. 6 reveals this consistency in the current profile through 385 recorded trip current signatures over a 3-year period under various seasonal and weather conditions. By time-aligning all events into a single plot, the consistency of the current profile becomes easily discernible.

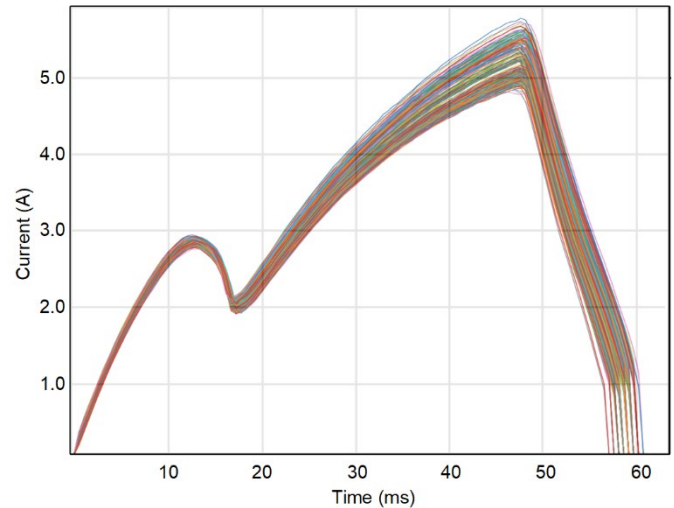

Fig. 6 385 Trip Operations From One Breaker Over 3 Years

It is important to note that deviations in the current profile may occur due to factors, such as ambient temperature, which affects the resistance of the TC. Changes in temperature can alter the electrical characteristics of the coil, leading to variations in the current profile. This effect is particularly evident in the later part of the postplunger movement phase, as expected, since this part of the signature is mainly dependent on the voltage and the combined resistance of the TC and circuit, rather than the L/R characteristics. Overall deviation sees less than 15 percent change in the current with only a few milliseconds of change in operating time.

### C. Variability in a Trip Current Profile Between Manufacturers and Models

Although an individual TC may exhibit consistency over time, and the general current profile is known, significant variations can be observed between different manufacturers and models of breakers and TCs. Fig. 7 displays the current profiles for six different breakers, ranging from 15 kV to 145 kV, and employing oil, vacuum, or SF6 as insulating mediums.

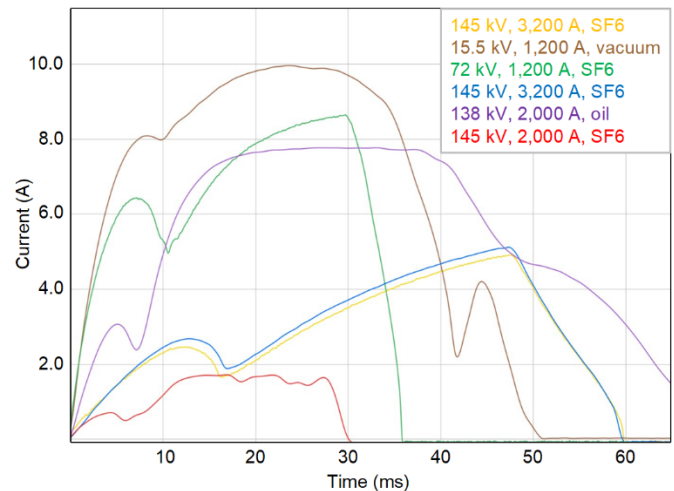

Fig. 7 Current Profile for Six Different Circuit Breakers

This variety in current profiles emphasizes the significance of developing an algorithm capable of working with a broad

range of profiles when using trip current for real-time applications or diagnostic purposes. To ensure the algorithm operates correctly on different types of circuit breakers and TCs, it is essential to understand these variations and use the four regions of the current profile described previously as a starting point for designing the algorithm. By basing the algorithm on these fundamental sections, specific characteristics of various circuit breakers and TCs can be accommodated, ensuring accurate analysis and monitoring across diverse systems.

## V. OUTPUT CONTACT AND CIRCUIT VERIFICATION ALGORITHM

The output contact and circuit verification algorithm design is based on insights gained from the common characteristics of the current profile described in Section III and an understanding of trip circuit topology. The following key aspects drive the simplicity and adaptability of the algorithm.

- Upon issuing a trip command and closing the output contact, the relay witnesses a rapid increase in the trip output current and a step decrease in the voltage across the output contact.
- The duration of the current signature is limited to the time it takes for the breaker to open and activate the auxiliary contacts.
- A rapid step decrease in voltage across the output contact without a trip command being issued signifies either a lost voltage source or a parallel device closing its trip contact.
- When the local relay initiates a trip after a voltage collapse, it should anticipate current flow through its trip contact only if the trip event takes place before the operation of the breaker auxiliary contact.

By taking these factors into account, the algorithm is designed to be versatile, catering to a wide range of TC current signatures found in breakers and even lockout relays (LORs).

### A. Output Successful (Trip Circuit Energization) Logic

To declare a successful output contact operation, the algorithm simply checks for current flow (trip circuit energization) through the contact after it is commanded to close. The logic for detecting a successful output contact operation is shown in Fig. 8. If current is measured through the output contact while the output contact control equation is asserted, the operation is declared successful. After a short security delay, the successful operation is sealed in until the output contact control equation deasserts, at which point it is reset for the next operation.

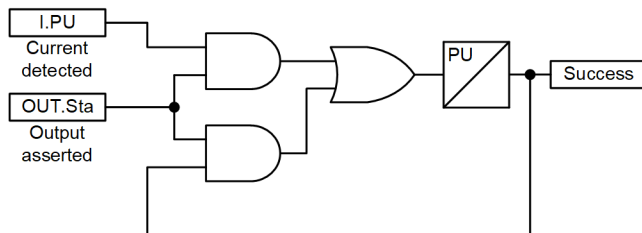

Fig. 8 Output Successful Logic

The current detection logic is shown in Fig. 9. There are two levels, each with thresholds that can be set by the user. Typical coils can draw anywhere from 2 to 12 Adc. It is important to set the operating current threshold ( $I\_Thresh$ ) low enough that it picks up on parallel trip events but not so low that noise in the current sensor becomes a problem. The operating current output ( $I\_PU$ ) is used in the output successful logic previously as well as in the failure, no-call, and slow breaker logic.

The high-current threshold ( $I\_Hi.Thresh$ ) should be set to 125 percent of the maximum expected coil current at the highest dc operating voltage. The high-current output ( $I\_Hi.PU$ ) is used in the high-current alarm logic. In some cases, such as three independent TCs operated from a single contact, the normal operating current may be near or above the clipping threshold of the current measurement. In those cases, the high-current threshold needs to be set above the clipping threshold to disable the  $I\_Hi.PU$  output, and subsequently, the high-current alarm.

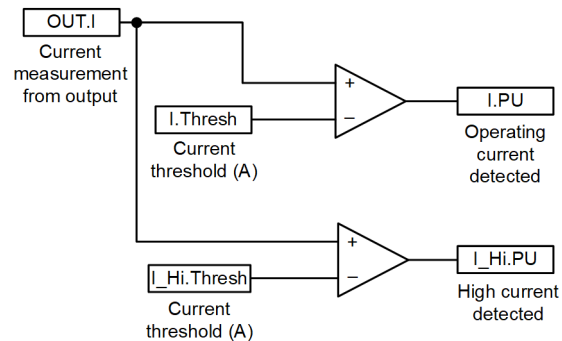

Fig. 9 Current Threshold Logic

### B. Determining Output Failure or No Call

#### 1) Trip Window (TW) Logic

To discriminate between output contact failures and other scenarios in which the contact is closed and no current is measured, the algorithm uses a window of opportunity (TW), which is armed on the detection of a voltage drop across the output contact. This TW defines the interval during which the relay can expect to measure current through a closed contact and consequently, the interval during which a closed contact with no measured current constitutes a failure. Additionally, the TW defines the expected duration of the measured trip current; if current is measured for significantly longer than the TW duration, this indicates a successful contact operation but an issue in the trip circuit or breaker.

Fig. 10 shows the TW logic. When any output in the trip circuit closes, the measured voltage across the CM contact drops to zero. The falling edge of  $V\_PU$  triggers the TW. The TW is critical for discriminating between output contact failures and other scenarios in which a determination of success or failure cannot be made.

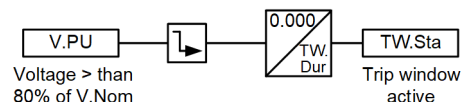

Fig. 10 TW Activation Logic

The dropout delay (TW.Dur) on the TW timer is set by the user. TW.Dur should be set to the average time duration of current flow through the coil. To determine TW.Dur, the next step is to operate the coil and gather an event report. Fig. 11 shows the measure of time between the deassertion of V.PU (OUT.V) and deassertion of I.PU (OUT.I).

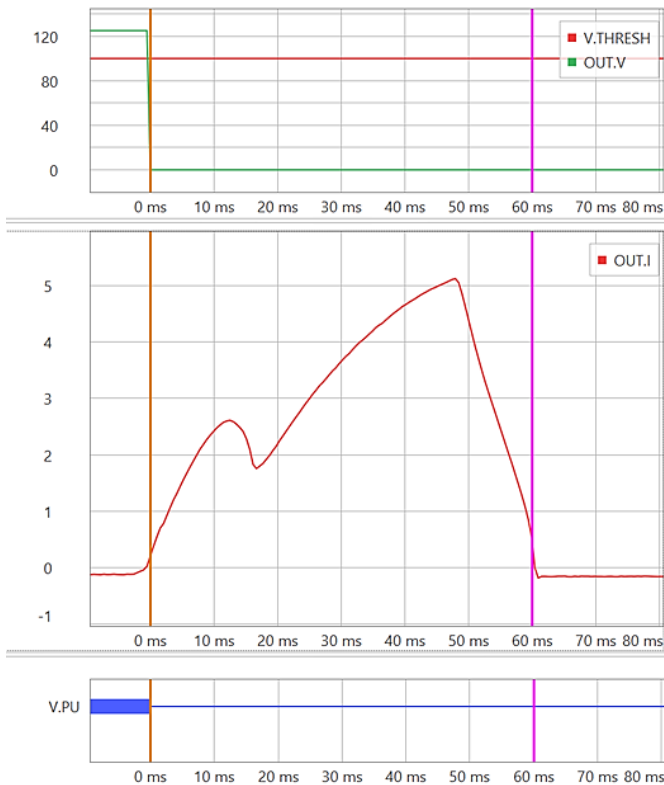

Fig. 11 Determining TW Timer TW.Dur

Another approach to determine the TW.Dur is using the breaker timing test report. Often before new breakers are put into service, one of the site-commissioning tests is a breaker timing test. This test captures the current signature as well as the main and auxiliary contact timing. A user could use that test report as a basis for setting the TW.Dur and then further adjust when commissioning the relay with the CM output.

The logic for overvoltage detection is shown in Fig. 12. Thresholds can be set by the user. Setting the voltage threshold (V.Thresh) to 80 percent of nominal ensures the quick detection of a voltage change but still allows for small fluctuations in the dc system. The V.Thresh must be set below the worst-case dc system operating voltage.

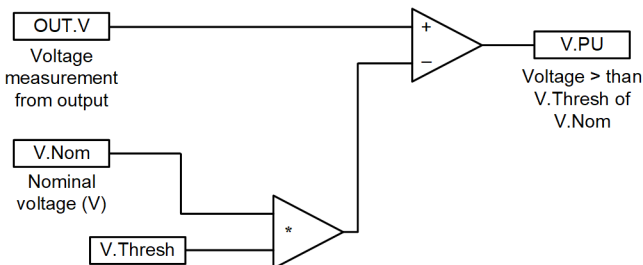
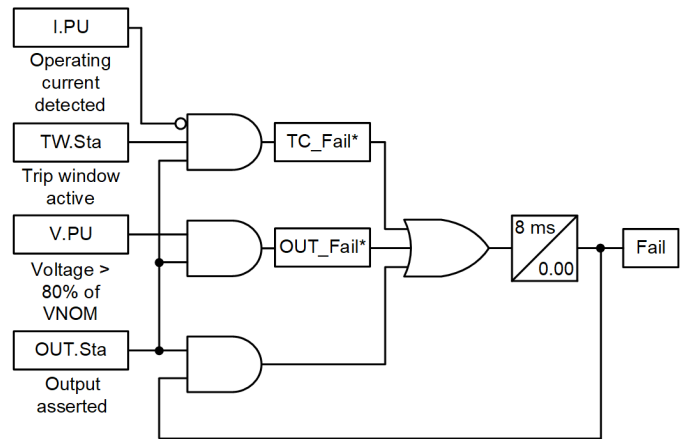

Fig. 12 Voltage Threshold Logic

### 2) Output Failure Logic

There are two scenarios to declare an output failure. In the first scenario (top AND gate shown in Fig. 13), the output contact control equation asserts while the TW is active, but no current is measured through the output contact (I.PU does not assert). In the second scenario (middle AND gate), the output contact control equation asserts, and the overvoltage detection remains asserted (V.PU does not deassert). If the conditions for either scenario are true for longer than the time it takes for the metallic contact to close (8 ms), a failed operation is declared and sealed in until the output contact control equation deasserts, at which point it is reset for the next operation.



\*For single-contact trip circuit configurations only

Fig. 13 Output Failed Logic

For configurations with only a single contact in the trip circuit, the logic in Fig. 13 can provide additional information about the type of failure. The assertion of the top AND gate (TC\_Fail) indicates the output contact closed (TW.Sta asserted), but some problem in the trip circuit prevented current flow sufficient to assert I.PU. The assertion of the middle AND gate (OUT\_Fail) indicates that the output contact failed to close, so the voltage remained high and TW.Sta did not assert. These outputs demonstrate additional information in single-contact trip circuits only.

### 3) No-Call Logic

A no call is for a race condition when two output contacts are tripping the same coil. For example, Relay A trips and the coil operates. A short time later, Relay B operates, but the coil has already been energized and completed its cycle. No current is measured, as shown in Fig. 14.



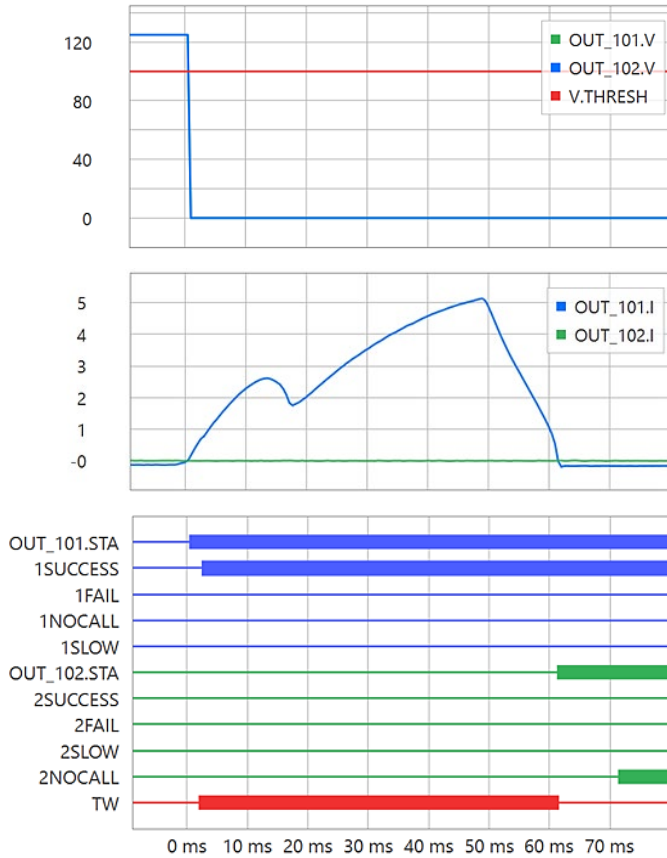

Fig. 14 Parallel Output Operation

In a trip circuit with multiple contacts in parallel, it is possible that a contact may be commanded to close after the breaker trip cycle is complete (i.e., after the TW asserts and then times out). In that case, it is not possible to determine whether the output contact operated successfully or failed to operate, and the algorithm returns a no-call result, as shown in Fig. 15. If the output control equation asserts and no current is measured but the TW is not armed, the no-call output is asserted after a short time delay. The no-call output is blocked by the success or fail outputs. The no-call logic is important to prevent false alarms in tripping schemes in which multiple devices can trip a coil.

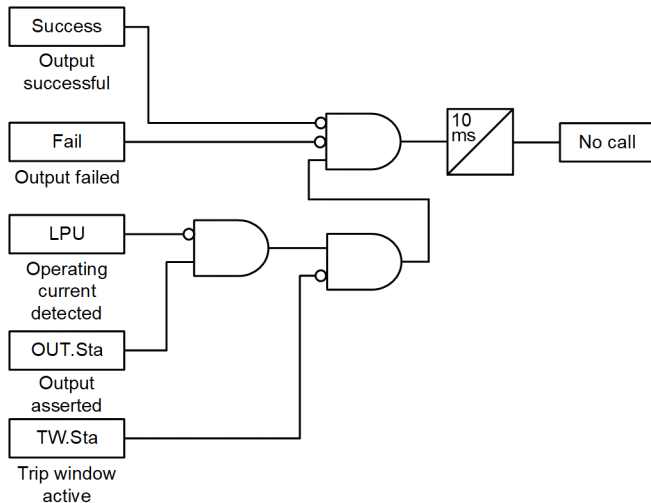

Fig. 15 Output No-Call Logic

#### 4) Slow Breaker, High Current, and Open-Circuit Detection

When operating current flow through the contact (IPU asserted) is measured for a duration longer than the TW duration, it indicates a slow breaker. Fig. 16 shows a normal operation of a breaker that takes around 55 ms to complete its full cycle. The curve also shows a slow operation that takes an additional 30 ms to complete its cycle.

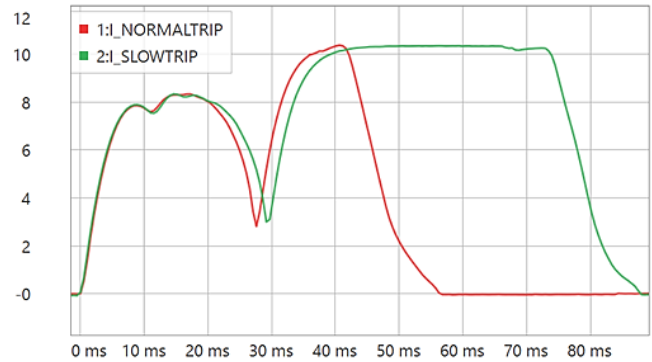

Fig. 16 Slow Breaker Operation

When current higher than the expected coil operating current is detected ( $I_{Hi.PU}$  asserted), the high-current alarm output (HiCurAlm) is asserted after a short, qualifying time delay, indicating a potential short in the trip circuit. The algorithm also detects slow breakers or high current in the trip circuit, as shown in Fig. 17.

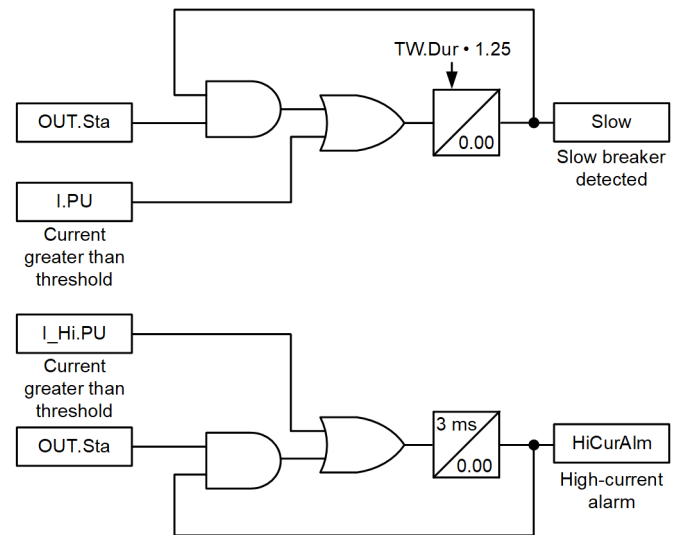

Fig. 17 Slow Breaker and High-Current Logic

Finally, the algorithm logic is complemented by a traditional steady-state TCM scheme, as described in Section I, to monitor for loss-of-control voltage, loose connections, and open-circuit conditions in the trip circuit.

#### C. Summary of Algorithm Response

Table II shows a summary of the algorithm response for some typical scenarios. For each case listed in the first column, the expected status of the algorithm outputs is shown in the corresponding row. For example, in the case of a slow breaker, the algorithm response indicates assertion of the TW and a

successful contact operation, but it also indicates that a slow breaker condition was detected.

TABLE II  
ALGORITHM RESPONSE

Case	Contact Monitoring				Breaker Monitoring	
	Success	TW. Sta	Fail	No Call	HiCur Alm	Slow
Successful operation	1	1	0	0	0	0
Output contact fails to close	0	0	1	1*	0	0
Open trip circuit	0	0	0	1†	0	0
Shorted trip circuit	1	1	0	0	1	0
Slow breaker	1	1	0	0	0	1
Failed 52a contact	1	1	0	0	1	0
Slow relay response	0	0	0	1‡	0	0

\*For isolated output contacts, the no-call output initially asserts and then is blocked by the fail output. For parallel output contact operation, the no-call output does not assert.

†Detected by traditional TCM scheme.

‡For parallel output contacts.

## VI. TESTING OF THE ALGORITHM

### A. Laboratory Tests

Using prototype hardware, two CM outputs are wired in parallel to trip a LOR to simulate a TC, as shown in Fig. 18. The behavior of parallel outputs energizing a coil is examined using this setup. The setup collects low- and high-resolution events of the current and voltage measured from the CM output. Various scenarios were tested, but for brevity, we investigate two scenarios in this paper. First, the two outputs are operated at the exact same time, and then they are operated with different delays in between.

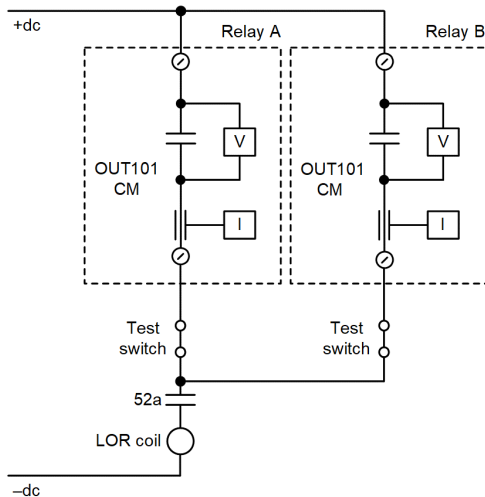

Fig. 18 DC Parallel Trip LOR

### 1) Parallel Trip

For the first scenario, Relay A and Relay B both trip at the same time. Fig. 19 shows the measured current and voltage to Relay A in red, Relay B in green, and the composite summed current in blue. As Relay A and B issue an output close command, we see the current being nearly evenly split between the two relays. A few milliseconds later, we can see the metallic contacts finally close and bounce. After that point, the current is distributed between the two contacts. Both relays initiate the TW at the same time and quickly declare the output operated successfully. It is also worth noting that the summed current of both relays depicted by the blue line creates an accurate TC current signature that can be utilized by condition-based monitoring systems.

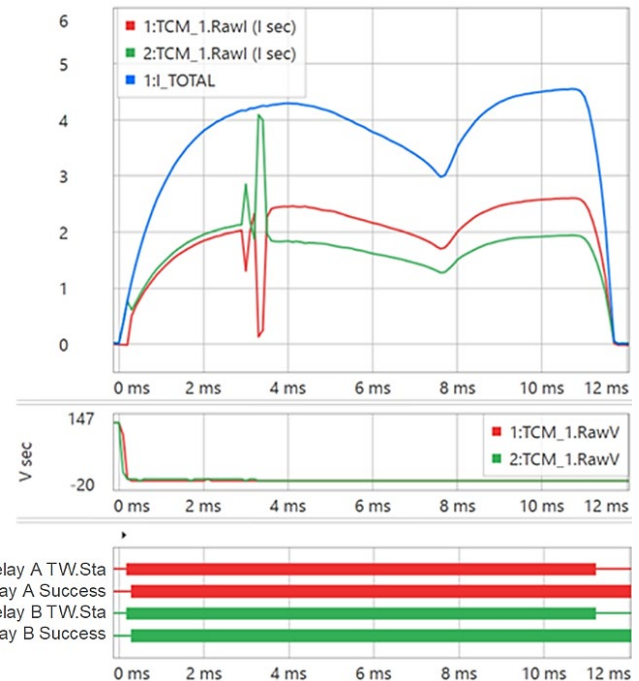

Fig. 19 Parallel Output Trip With Relay A Operating at the Same Time as Relay B

### 2) Sequential Trip

For the second scenario, Relay A trips and then Relay B trips 8 ms later. Fig. 20 shows the measured current and voltage to Relay A in red, Relay B in green, and the composite summed current in blue. We see both relays trigger the TW at the same time. Relay A carries the full current and gets the TC operating 8 ms into the event, Relay B then trips and takes a portion of the current. Relay A declares a successful output within 1 ms of tripping. Relay B is still able to confirm successful output assertion. We again see that the summed currents shown in blue are an accurate representation of the TC current signature.

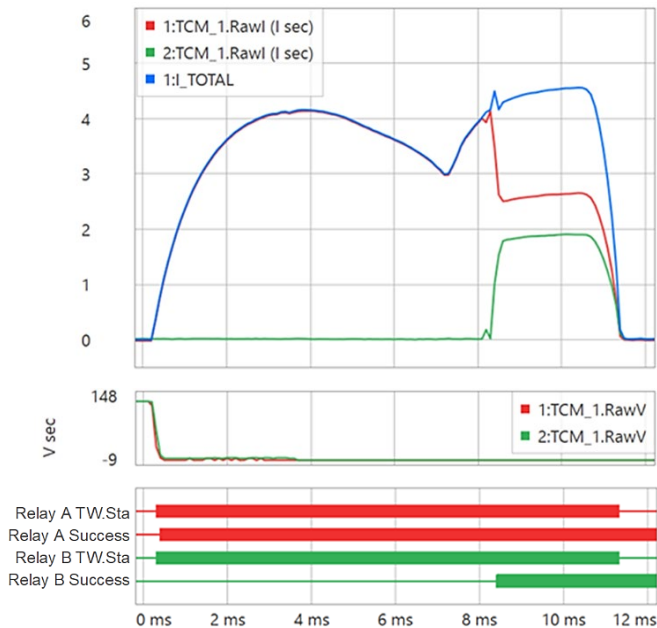

Fig. 20 Parallel Output Trip With Relay A Operating 8 ms Before Relay B

### B. Events From Tripping Breakers With Prototype Hardware

The same prototype hardware is tested on six different 15 kV vacuum circuit breakers in a switchgear lineup. The breakers are the same manufacturer and type, with a TC operating voltage range of 100 to 140 Vdc and a current rating of 6.6 Adc. OUT101 and OUT102 on a relay equipped with CM outputs and programmed with the algorithm described in Section IV are wired in parallel with the trip outputs on the existing switchgear relays.

Fig. 21 shows the dc current measured by the CM output for a trip operation on each of the breakers. As expected, there is some small variation in the trip current profiles, but each exhibits the regions described in Section III.A., and the overall operating times are within a few milliseconds of each other.

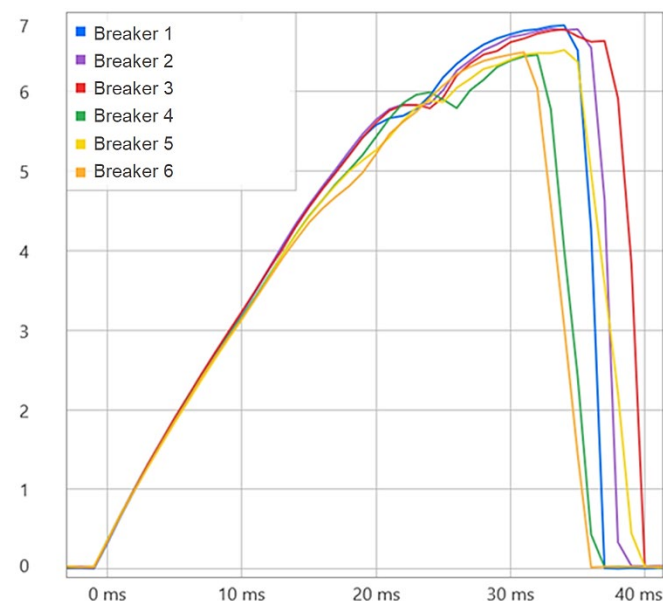

Fig. 21 Comparing Different Breakers of the Same Manufacturer and Type

Fig. 22 shows six trip operations on the same breaker. The first four operations were performed with an operating voltage of 133 Vdc; there is very little difference in the trip current profiles for these operations. The fifth operation is performed with a reduced control voltage of 110 Vdc. The reduced voltage results in a lower trip current magnitude and an approximately 5 ms slower breaker operation. The sixth operation is performed with an increased control voltage of 140 Vdc. The elevated voltage results in a higher trip current magnitude and a faster breaker operation.

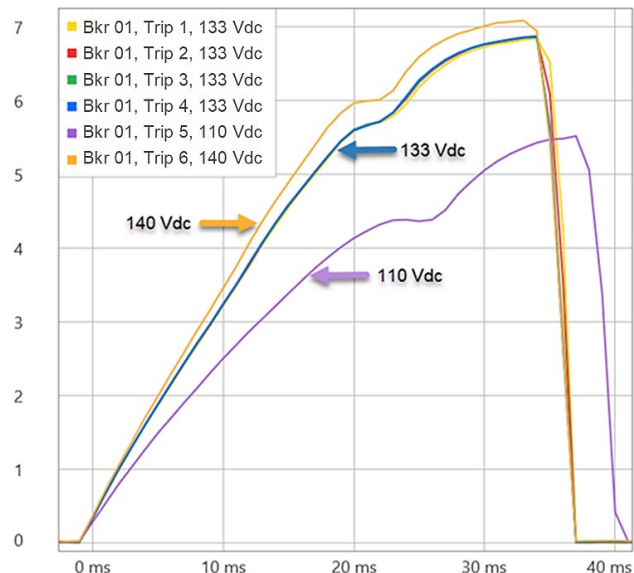

Fig. 22 Comparing Multiple Trip Operations on the Same Breaker

These figures demonstrate the detailed information, which can be extracted from the CM output technology. Additionally, a number of other tests are performed to validate the logic in Section IV, including successful parallel trips, no-call parallel trips, slow breaker operations (by manipulating the TW setting), and trip contact failures. In all cases, the logic performs as intended.

## VII. APPLICATIONS

### A. Preventing Hidden Failures in Trip Circuits

Protection systems are designed with fault tolerance in mind, enabling them to fulfill their intended function even in the event of a single-component failure, often referred to as N-1 tolerance. Failures can be broadly classified as detectable and undetectable. Detectable failures can self-announce or alert operators to the troubled component through automated self-testing or system-wide monitoring. Undetectable failures remain undetected until manually identified and rectified, these are also known as hidden failures.

If a failure remains undetected by system self-testing or monitoring, it has the potential to evolve into an N-1-1 failure. One example of a system design that can create an undetectable hidden failure occurs when redundant relays cross-trip multiple TCs. Circuit breakers commonly employ multiple TCs to enhance reliability. A common practice is to energize both TCs simultaneously during each trip event or activate the secondary

TC after a brief delay. This ensures that the breaker still trips promptly, even if one coil fails [12].

The problem with this configuration is a malfunctioning TC or output contact might go unnoticed because the other functional coil can still open the breaker.

If Relay A in Fig. 23 cross-trips TC1 or TC2 and the breaker opens, there is no indication that each trip circuit operated correctly, only that the combined combination of TC1 and TC2 resulted in the breaker tripping. Alternatively, if Relay A and Relay B both assert the operating logic for OUT1\_A and OUT1\_B at or at near the same time, it is difficult or impossible to determine if each output contact operated correctly. Presently, the only way to find these failures is through event report inspection, through manual testing, or worse, when another cascading failure occurs.

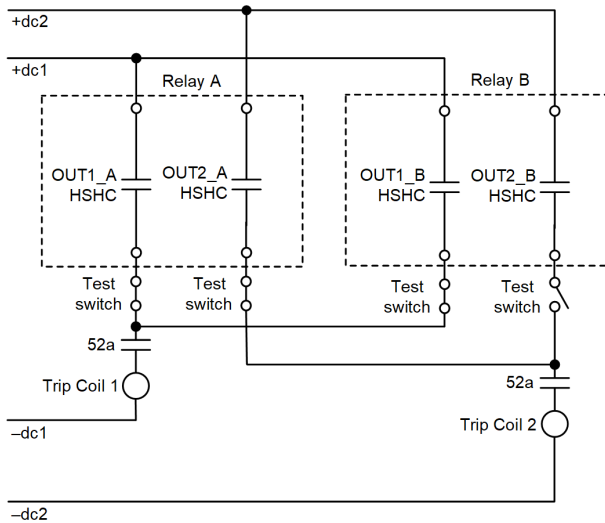

Fig. 23 Cross-Tripping

Applying CM output contacts, as shown in Fig. 24, prevents these hidden failures by making them detectable. The algorithm determines failures on individual trip contacts and paths even when there are parallel trip paths and devices with and without CM.

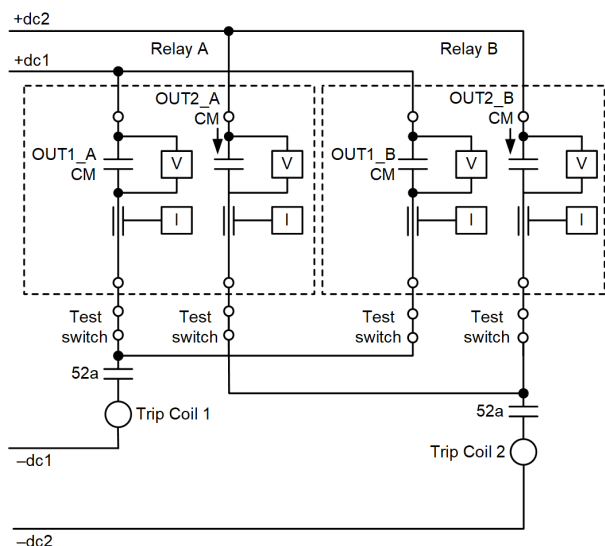

Fig. 24 Cross-Tripping With Monitoring

Another example of a hidden failure is in applications that parallel three TCs to a single relay output to three-pole trip breakers that support single-pole tripping. In this configuration, traditional TCM schemes cannot detect open circuits on individual TCs. Using a CM output allows for monitoring of the peak trip current for all three coils. If one of the coils is an open circuit, the peak current is two-thirds of the peak current compared to all three coils.

### B. NERC PRC-005

To improve the reliability of North America's bulk electric system (BES), the U.S. Federal Energy Regulatory Commission has tasked NERC with developing a compliance program. This program focuses on enhancing the reliability of protection systems for generation and transmission facilities that can impact the BES. The NERC Standard PRC-005-2 requires these generation and transmission facilities to have a protection system maintenance program that identifies maintenance methods, such as time-based, performance-based, or a combination used to address each system component [13].

Many other sources, including [14] and [4], have presented automated methods to monitor, test, and record PRC-005 protection components, essentially formalizing what [1] discusses, in which a substation continuously tests itself.

However, a crucial gap in self-testing remains—validating output contacts. This necessitates manual verification, hindering automated compliance with [13] requirements for verifying trip circuit paths and ensuring functionality of TCs, including LORs.

Using the CM output for all station trip paths for circuit breakers and lockout relays, it becomes simple to incorporate automated validation, closing one of the last gaps of relay self-testing.

### C. Manual Trip Verification

Reference [1] discusses the benefits of using protective relay trip outputs for manual trip operations. Using the trip output for a manual trip allows for verification of the entire trip circuit every time the breaker is operated. This approach simplifies wiring while also possibly having a failure become known during a manual operation and not when there is a fault on the power system.

The CM output allows for this testing to be further automated by capturing successful or failed output logging.

Logic within the relay could then capture the last successful operation of every trip output and display the inactivity or the number of days since the last operation. The output selected by manual trip operation could be determined by the longest inactive contact, which exercises all trip outputs and coils. Outputs could alert if they sit idle for a predetermined length of time.

### D. Trip Seal-In

During a trip operation, either performed manually from SCADA, front panel, or a protection element operating, the output contact must stay closed once asserted. Relay contact damage or partial TC operation may occur during momentary assertions. Historically, a minimum trip duration timer and

programmable trip unlatch logic have been implemented to solve these problems. With the CM output contact, there is now the ability to measure current through the output and perform a seal-in (Fig. 25) whenever current is actively flowing through the output, eliminating damage to output contacts due to momentary assertions or slow 52a contacts relative to the breaker main contacts.

Seal-in current thresholds should be set low (0.5 A) to ensure an output does not open while current is still flowing for a more dependable approach or at the maximum contact break current if the main concern is to prevent damage to an output contact.

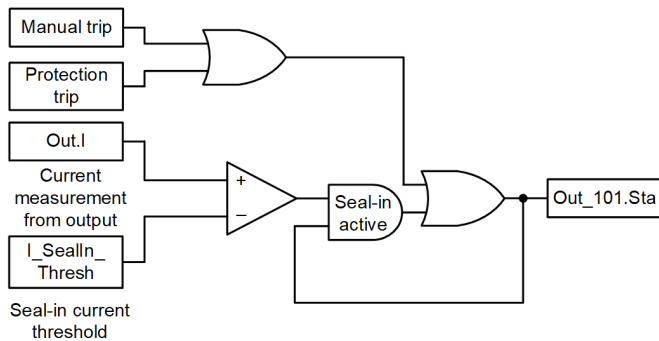

Fig. 25 Output Seal-In Logic

## VIII. CONDITION-BASED MONITORING

### A. Trip Circuit Assembly Monitoring With No Additional Equipment

Many others have proposed methods of measuring and characterizing the trip current signatures, which are indicative of specific failures in the TC and even the breaker mechanism. Prior to protective relays with CM outputs, measuring and recording these signatures required additional equipment to be installed permanently or temporarily. Reference [15] presents a real-time circuit breaker health-monitoring system utilizing a breaker protective relay and real-time automation controller with remote I/O capable of capturing the breaker coil signature using an external Hall-effect sensor. Is it due to cost or complexity? We can only speculate why this monitoring has been relegated to critical breakers or to utilities attempting to reduce O&M costs through condition-based maintenance protocols.

In place of a permanent installation, [10] developed one of the first portable trip circuit current signature monitors. The approach was to create a baseline a breaker during the initial installation and verify characteristics during each maintenance interval, or after indication of a problem, such as a slow breaker operation. However, it was soon discovered that reactive monitoring may hide certain failure modes, such as inadequate lubrication. They found that after responding to a slow breaker and connecting the portable monitor, the signature and breaker timing indicated a healthy breaker. After further investigation on over 700 circuit breakers, they found that first trip events on breakers with lubrication issues self-rectified on subsequent trip events. This lack of first trip events on problem breakers requires periodic maintenance intervals to capture problematic events.

Integrating this recording capability into the protective relay output allows for a simple and economical approach to collect these data. Additionally, these relays may be connected to data concentrators that already collect status, event records, and Sequence of Events (SOE) data. As more data are captured and the industry develops protection systems with enhanced self-testing capabilities, the way is paved for complete condition-based and performance-based maintenance strategies, effectively reducing or eliminating unnecessary maintenance activities.

### B. Relay Contact, High-Current Breaking Alarm

As mentioned in Section I, trip contacts are unable to break 30 A and must use external means to break the current. Allowable breaking current is often listed by the relay manufacturer. The user configures the CM output to alert users that the output opened at or above the rated current breaking capacity by looking at the falling edge of the output status while the output current is greater than the rated breaking current. This alert serves as an indication of potential incorrect application or a malfunctioning component within the circuit, such as a failed breaker auxiliary contact.

## IX. INVESTIGATING PROTECTION APPLICATIONS

The algorithm presented offers a variety of potential protection applications that can enhance the performance and reliability of protective relays and circuit breakers. Some of these applications include bypassing the breaker failure (BF) trip timer for known failures and implementing a retrip with alarming.

### A. BF Retrip With Alarming Function

BF protection is designed to detect the failure of a circuit breaker to interrupt a fault. It is a backup function substituting for breaker redundancy [16]. When a BF condition is detected, the scheme is designed to trip all breakers in adjacent zones that could contribute to the fault. Because the BF operation results in tripping breakers in adjacent zones, which isolates more than just the faulted zone, the consequence of a false BF operation is typically serious. Therefore, BF is often biased toward security over dependability.

One common method to add security to a BF scheme is to implement a BF retrip, as shown in Fig. 26. A BF retrip uses a second contact output to attempt a second trip path to the breaker. Depending on the utility practice, this second trip path may be applied to the second TC to mitigate any failures of the first TC. The retrip output may include a short delay to help identify when the primary trip path fails or to provide security from spurious BFI when the fault detector is set below the load current [17] [18].

It is important to note that the retrip delay must be coordinated with the BF timer to ensure the second trip path has a chance to operate the breaker before the BF time expires and causes a BF trip.

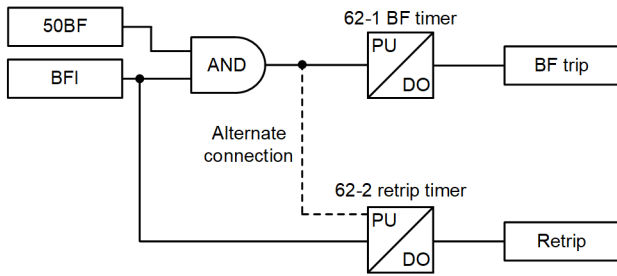

Fig. 26 BF With a Retrip

While the retrip function adds security to the BF scheme, it has the potential to add another hidden failure. In present implementations, the only way to determine if the primary trip path failed and that the retrip path was responsible for tripping the breaker is by manually investigating an SOE record or an event record. At present, we are unaware of any automated alarming indicating that the breaker trip circuits should be investigated.

Utilizing the CM outputs for the main, and, optionally, the retrip path, provides an automated method to alarm personnel if a primary trip path failed to operate. This also allows for reducing the retrip delay to a short duration (4 to 8 ms) for security against spurious BFI because we no longer need the delay to help determine if the primary trip path operated correctly.

#### B. Bypass BF Trip Timer for Known Failures

Reference [16] discusses BF timer bypass schemes, which prevent unnecessary delays in declaring BFs if prior knowledge of the breaker operating status is known. One example of this is on a gas breaker that blocks operation when the SF6 gas pressure drops below a safe level. An additional pressure switch contact is then used in the BF scheme to indicate that the breaker will not operate and instruct it to bypass the BF timer.

The BF bypass could also be implemented when tripping a breaker using the CM output contact, shown in Fig. 27. In this scenario, the relay issues a trip command, and if the CM output does not see a rapid rise in dc current through the output, it can quickly declare a problem and initiate a backup action before the BF timer expires.

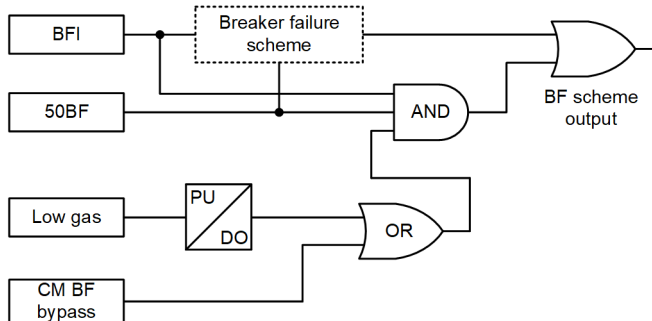

Fig. 27 Example BF Bypass Scheme

The implementation of this approach is dependent on how the relay is applied. In a protection zone with only one protective relay tripping a single TC commonly found on feeder breakers, the relay can issue a BF trip without delay once it declares the trip circuit failed.

In protection zones with multiple relays tripping multiple TCs on a breaker, the logic must initiate other actions before declaring a BF condition. In this scenario, if Relay A issues a trip and declares the output circuit failed, it could then issue a failed circuit retrip on another output to the second TC or send a signal to Relay B to issue a failed circuit retrip on the second TC. If Relay B issues a trip to the secondary coil and it declares a circuit failure, then after receiving a failed circuit retrip signal, we can declare a BF and bypass the BF timer. The CM output can declare the circuit has failed within a few milliseconds, and accounting for both relays and signaling time, the BF can be accomplished in less than 1 cycle.

#### C. BF Timer Extension

Lower voltage applications use BF primarily for reduction of equipment damage and not for power system stability. For these applications, it may be desirable to use the trip current characteristic to extend the BF timer. An example of this is a BF scheme implemented on a 12 kV distribution bus that feeds critical industrial processes. If the signature shows that the breaker trip latch operated and we suspect the breaker mechanism to be moving slower than normal, the 62 timer could be extended from 12 cycles to a longer delay, giving the breaker extra time to operate and preventing a BF trip and keeping critical processes online. After this slow operation, personnel could be notified that the breaker operated slowly and may need maintenance or repair.

## X. LOOKING TO THE FUTURE

As the CM outputs collect data from more breaker tripping and closing events, we hope to further investigate how these data can be used to automate TW length, be used in protection schemes to help determine TC and breaker health, and be used to improve reliability of protection systems. Additionally, we anticipate the wide-area collection of all trip current signatures in which a central repository analyzes every signature for telltale signs of failures or maintenance needs.

## XI. CONCLUSION

As the industry looks to lower O&M costs and to increase the reliability of protection systems, it is crucial to ensure protection system self-testing covers all components. The introduction of a trip contact with integrated CM and the contact operation verification algorithm, as presented in this paper, closes one of the last gaps to protection self-testing, ensuring the proper functionality and performance of protection schemes.

Integrating current monitoring into each relay is no longer cost-prohibitive, making it feasible to implement complete circuit verification for all trip and close circuits. Using this CM output and algorithm on all tripping outputs allows for protection systems to monitor and alert for failures. It makes undetectable hidden failures found in cross-tripping and BF retrip schemes detectable. Manual tripping initiated through these outputs also ensures entire trip circuits are being tested and confirmed during routine switching.

The algorithm continues to function during parallel trips from different relays, allowing for the accurate detection and assessment of trip operations when parallel tripping devices do not have monitoring capabilities. It also prevents declaring false contact failures when a relay trips after the TW has expired.

## XII. ACKNOWLEDGMENT

We gratefully acknowledge the contributions of Michael Thompson, Bernard Matta, Dale Finney, Derrick Haas, Daqing Hou, and Normann Fischer.

## XIII. REFERENCES

- [1] M. Thompson, "The Power of Modern Relays Enables Fundamental Changes in Protection and Control System Design," proceedings of the 60th Annual Conference for Protective Relay Engineers, College Station, TX, March 2007.
- [2] IEEE, "Relay Scheme Design Using Microprocessor Relays," proceedings of the 68th Annual Conference for Protective Relay Engineers, Working Group C16, June 2014, pp. 405–447.
- [3] A. Genz, D. Haas, and K. Zimmerman, "Test the Right Stuff: Using Data to Improve Relay Availability, Reduce Failures, and Optimize Test Intervals," proceedings of the 75th Annual Conference for Protective Relay Engineers, College Station, TX, March 2022.
- [4] D. Stewart, R. Jenkins, and D. Dolezilek, "Case Study in Improving Protection System Reliability With Automatic NERC PRC-005 Inspection, Testing, Reporting, and Auditing," proceedings of the 39th Annual Western Protective Relay Conference, Spokane, WA, October 2012.
- [5] IEEE Std C37.90-2005, *IEEE Standard for Relays and Relay Systems Associated with Electric Power Apparatus*.
- [6] X. Gao, J. S. Thorp, and D. Hou, "Case Studies: Designing Protection Systems That Minimize Potential Hidden Failures," proceedings of the 39th Annual Conference for Protective Relay Engineers, Spokane, WA, October 2012.
- [7] M. Biglarbegian, S. J. Nibir, H. Jafarian, and B. Parkhideh, "Development of Current Measurement Techniques for High Frequency Power Converters," proceedings of the IEEE International Telecommunications Energy Conference, October 2016, pp. 1–7.
- [8] *SEL-411 Advanced Line Differential Protection, Automation, and Control System Instruction Manual*. Available: selinc.com.
- [9] S. S. Biswas, A. K. Srivastava, and D. Whitehead, "A Real-Time Data-Driven Algorithm for Health Diagnosis and Prognosis of a Circuit Breaker Trip Assembly," *IEEE Transactions on Industrial Electronics*, Vol. 62, No. 6, June 2015, pp. 3822–3831, doi:10.1109/TIE.2014.2362498.
- [10] S. Beattie, "Circuit Breaker Condition Assessment by Vibration and Trip Coil Analysis," *IEEE Colloquium on Monitors and Condition Assessment Equipment*, Digest No. 1996/186, 1986, pp. 9/1–9/5.
- [11] S. Strachan, S. McArthur, J. McDonald, W. Leggat, and A. Campbell, "Trip Coil Signature Analysis and Interpretation for Distribution Circuit Breaker Condition Assessment and Diagnosis," proceedings of the 18th International Conference and Exhibition on Electricity Distribution, 2005, pp. 1–5, doi: 10.1049/cp:20050987.
- [12] J. L. Blackburn and T. J. Domin, *Protective Relaying: Principles and Applications*, 3rd ed. CRC Press, Boca Raton, FL, 2006.
- [13] NERC Standard PRC-005-2, *Protection System Maintenance*. Available: nerc.com.
- [14] D. Kite, J. Otto, and I. West, "Simplifying Compliance: An Integrated Approach to Meeting NERC PRC-002 and PRC-005 Requirements," proceedings of the Power and Energy Automation Conference, Seattle, WA, March 2020.
- [15] J. Byerly, C. Schneider, R. Schloss, and I. West, "Real-Time Circuit Breaker Health Diagnostics," proceedings of the 43rd Annual Western Protective Relay Conference, Spokane, WA, October 2016.

- [16] IEEE Std C37.119-2016, *IEEE Guide for Breaker Failure Protection of Power Circuit Breakers*.
- [17] B. Kasztenny and M. Thompson, "Breaker Failure Protection – Standalone or Integrated With Zone Protection Relays?" proceedings of the 37th Annual Western Protective Relay Conference, Spokane, WA, October 2010.
- [18] H. Altuve, M. Thompson, and J. Mooney, "Advances in Breaker-Failure Protection," proceedings of the 33rd Annual Western Protective Relay Conference, Spokane, WA, October 2006.

## XIV. BIOGRAPHIES

**Austin Wade** received his BS in electronic and electrical engineering, summa cum laude, from California State University, Sacramento, in 2013. He joined Schweitzer Engineering Laboratories, Inc. (SEL) in 2012. He is presently a senior application engineer in research and development. He has experience in protection and control system design, communications-based protection schemes, substation automation, testing, and maintenance. Prior to receiving his BS, he worked for an electrical testing company as a testing technician and certified electrician. He is a registered professional engineer in the state of California and is a senior member of the IEEE Power and Energy Society. He holds numerous patents and has authored several papers related to power system protection.

**David Schmidt** received his BS in physics from Vanderbilt University in 2000 and his ME in electrical engineering from the University of Idaho in 2017. He joined Schweitzer Engineering Laboratories, Inc. (SEL) in 2009 as a protection engineer and project manager in the SEL Engineering Services, Inc. (SEL ES) group, working on protection and control design and relay settings. He is presently a development engineer in research and development working on product development. He is a registered professional engineer in the states of Washington and California and a member of IEEE.

**Brandon Nafsinger** received his BS degree in electrical engineering from the University of Idaho in 2017. He joined Schweitzer Engineering Laboratories, Inc. (SEL) in 2015. He is presently a development lead engineer in research and development. He has experience in power system protection design and commissioning, short circuit and coordination studies, logic design, and relay settings. Prior to receiving his BS, he served in the United States Army. He is a registered professional engineer in the state of Idaho and is a member of the IEEE.

**Jordan Bell** received his BSEE from Washington State University in 2006. He joined Schweitzer Engineering Laboratories, Inc. (SEL) in 2008 as a protection engineer in the SEL Engineering Services, Inc. (SEL ES) group. He is currently a senior engineer working on protection and control, event report analysis, relay settings and coordination, and performing model power system testing with a real-time digital simulator. He is a registered professional engineer in the state of Washington and a member of IEEE.