



## 2024 Product and Solution Guide



## New Products

SEL-787Z High-Impedance Differential Relay and SEL-HZM High-Impedance Module	16,24
SEL-3350 3U Computing Platform	16,41
Data Management and Automation (DMA) Application Suite—Meter Monitoring	42

## Contents

Trending Topics in Electric Power Systems	1
About SEL	2
SEL Power System Solutions	6
SEL Network Communications	8
Generator Protection	10
Industrial and Commercial Protection	14
Transmission Protection	18
Substation Protection	22
Distribution Protection and Control	28
Fault Indicators, Sensors, and CTs	34
Metering	38
Automation	40
WAN and LAN Networks	46
Wireless Communications	50
Precise Time	52
Transceivers and Adapters	54
Cables	56
Remote I/O	58
Annunciation and Notification	59
Software	60
Accessories and Tools	63
Custom Panels and Enclosures	64
Direct-Replacement Assemblies	65
Engineering Services	66
Ordering	67
Education and Training	68
Customer Support	70
Index	72

# Trending Topics in Electric Power Systems

## Cybersecurity

Security has been a top priority at SEL for nearly 40 years. From products to services, we are ready to be a partner in securing your critical infrastructure.

## Regulatory and Framework Compliance

SEL Engineering Services experts have extensive experience securing industrial control system (ICS) and operational technology (OT) environments while leveraging industry best practices and regulatory standards, such as those outlined in NERC CIP, the NIST Cybersecurity Framework, and IEC 62443. Visit [selinc.com/products/security/regulatory-compliance](https://selinc.com/products/security/regulatory-compliance) to learn more about related products.

## Cyber Services

From system assessment and baselining to cyber-defense solution development and ongoing system management, our full suite of security services from SEL Engineering Services helps strengthen your defenses and streamline the demands of maintenance and compliance. Learn more at [selinc.com/engineering-services/cybersecurity](https://selinc.com/engineering-services/cybersecurity).

## Supply Chain Risk Management

SEL prioritizes supply chain security to ensure the quality and trustworthiness of our products and solutions. We employ a five-part approach to evaluating the supply chain risk—we build trusted supply networks, ensure component integrity and availability, verify security of software and firmware, protect operations and control access, and monitor for quality and security vulnerabilities. Listen to the Schweitzer Drive podcast “Supply Chain Management: Getting Parts to Make Parts” at [selinc.com/company/podcast/supply-chain](https://selinc.com/company/podcast/supply-chain) to learn more.

## Wildfire Mitigation

SEL offers solutions to support your wildfire mitigation efforts and to ensure the availability and reliability of electric power. Visit the Transmission Protection and Distribution Protection and Control sections of this guide to learn more about related products.

## Microgrid Control Systems

With SEL's POWERMAX® family of microgrid control systems, you can operate an independent power system with a wide variety of conventional and renewable energy sources to provide uninterrupted power, optimize operational costs, and protect people and equipment during short-circuit events. SEL ranked as the top vendor of microgrid control systems in the Guidehouse Insights 2021 leaderboard report. Learn more at [selinc.com/solutions/microgrid-control](https://selinc.com/solutions/microgrid-control).

## Retrofit Solutions

From individual device upgrades to system-wide modernization projects, SEL is here to help simplify your retrofit programs and integrate advanced protection, control, automation, and communications technologies into your existing infrastructure. We offer mounting adapters and direct-replacement assemblies for a variety of existing equipment, as well as comprehensive services to support you throughout the entire retrofit process. Visit the Engineering Services and Direct-Replacement Assemblies sections of this guide to learn more.

**Our Mission: Making Electric Power Safer, More Reliable, and More Economical**

SEL invents, designs, manufactures, and supports a complete line of products and services for the protection, monitoring, control, automation, and metering of electric power systems.

Our solutions range from comprehensive generator and transmission protection to distribution automation and control systems.

Our Engineering Services division partners with customers globally to create turnkey solutions and services that help protect and control critical electrical infrastructure worldwide. We also offer education and full product support.

SEL products are in 168 countries and support industries from petrochemical to transportation to electric utilities.







Dr. Edmund O. Schweitzer, III  
 Inventor of the world's-first digital  
 protective relay—the SEL-21.

### Industries We Serve

- Electric power generation
- Power transmission and distribution
- Oil, gas, and petrochemical
- Renewable energy
- Metals and mining
- Water and wastewater
- Pulp and paper
- Mission-critical power systems
- Government
- Education and healthcare
- Consumer product manufacturing
- Transportation

### Looking Back, Moving Forward

SEL Founder, President, and Chief Technology Officer Dr. Edmund O. Schweitzer, III, invented the first microprocessor-based digital protective relay, the SEL-21, in 1982. The SEL-21 revolutionized the electric power industry by providing reliable transmission line protection with fault locating at a much lower cost than traditional electromechanical relays.

In the decades since, SEL has launched power industry innovations including the load-encroachment element in a transmission relay, synchrophasors as a standard feature in protective relays, and MIRRORING BITS® relay-to-relay communications.

### 2020

We added the SEL-T401L Ultra-High-Speed Line Relay to our family of protective relays, automation controllers, digital secondary system solutions, recloser controls, and more. The SEL-T401L is the first relay in the world to combine traveling-wave and incremental-quantity elements with phasor-based protection.

### 2021

We released our newest overcurrent protection relay, the SEL-851 Feeder Protection Relay, as well as our operational technology (OT) application platform, Blueframe®, and its first application suite, SEL Data Management and Automation (DMA).

### 2022

We introduced the SEL-2240 Axion® bay controller, and SEL FLISR (fault location, isolation, and service restoration), a wide-area control application that operates on our Blueframe application platform to locate and isolate faults and automatically restore power to healthy portions of affected lines or feeders.

### 2023

We made major enhancements to our IEC 61850-based solutions, including a new gigabit Ethernet card for SEL-400 series relays and Parallel Redundancy Protocol (PRP) support for Sampled Values (SV)-based process bus applications.

We are excited to make even more introductions in the coming year, including the SEL-TWFL Dual Traveling-Wave Fault Locator and 12-Channel MHz Recorder for precise fault locating and line monitoring.

## Quality in Manufacturing

We design and manufacture all our electronic devices in the U.S.A. This allows for direct collaboration and short feedback loops between our research and development and manufacturing divisions as well as world-class supply chain security. We manufacture our own critical components, like metal cabinets, printed circuit boards (PCBs), and magnetic devices, in our secure, SEL-owned and -operated facilities in Washington, Idaho, Illinois, and Indiana.

SEL exceeds industry quality standards, requirements, and customer expectations. We test our products thoroughly and verify that they will perform under demanding and harsh conditions.

Our quality practices include:

- Monitoring and controlling processes to exceed the ISO 9001:2015 Quality Management Systems Standard.
- Developing robust, repeatable, and scalable manufacturing processes to address process errors.
- Ensuring that our test and calibration laboratories use the latest equipment and follow National Institute of Standards and Technology (NIST) traceable standards for accuracy and maintenance.
- Partnering with our suppliers for the highest possible quality and value.



“As an engineering company, we work every day to invent, design, and support products that monitor, control, and protect power systems installed all over the world. Serving our industry is a tremendous privilege and responsibility that we take very seriously. Listening to our customers’ requirements and needs, we strive to make our solutions innovative, reliable, easy to use, and secure. We invest in our people, tools, and facilities in order to produce designs that exceed our customers’ requirements. Engineering is our middle name, and it’s what we love to do.”

**Dave Whitehead**  
Chief Executive Officer

---

## Warranty, Service, and Support

We back our products with a ten-year warranty, no-charge diagnostic and repair services, local support, and a variety of test procedures and certifications.

Our dedicated support teams are located in regional offices around the globe and staffed with SEL application engineers who are experts in our products and in power system applications. We offer free, 24/7 emergency technical support for the life of your SEL products.

Many support questions may also be answered by visiting our video portal at [video.selinc.com](http://video.selinc.com), where you’ll find how-to and support videos ranging from product set up and configuration to report retrieval and resource management.

## Learn More

Read more about our history, products, and practices at [selinc.com/company/about](http://selinc.com/company/about).



# SEL Power System Solutions

SEL creates digital products and systems that protect, control, automate, and secure power systems. Our devices help keep power flowing, prevent widespread blackouts, reduce outage durations, improve reliability and safety, and secure equipment, substations, and critical infrastructure.

## Generation Systems

Our generation solutions provide primary and backup protection from stator and rotor faults in salient pole and round rotor generators. These devices help prevent equipment damage and failures while maintaining system performance and increasing availability.

## Transmission Systems

SEL transmission solutions protect high-voltage power lines, transformers, busbars, switchgear, and more. Our devices help reduce outages, speed up restoration times, and pinpoint a fault's location.

## Distribution Systems

Our distribution solutions combine protective relays, recloser controls, communications, automation, and power quality devices. They protect equipment, integrate distributed energy resources, improve reliability metrics, reduce outages, and more.

## Industrial and Commercial Systems

For petrochemical, metals and mining, and water and wastewater facilities as well as data centers, hospitals, and universities, SEL offers a wide range of solutions for low- and medium-voltage systems. Our devices protect infrastructure, keep processes online, increase efficiency, and keep workers safe.

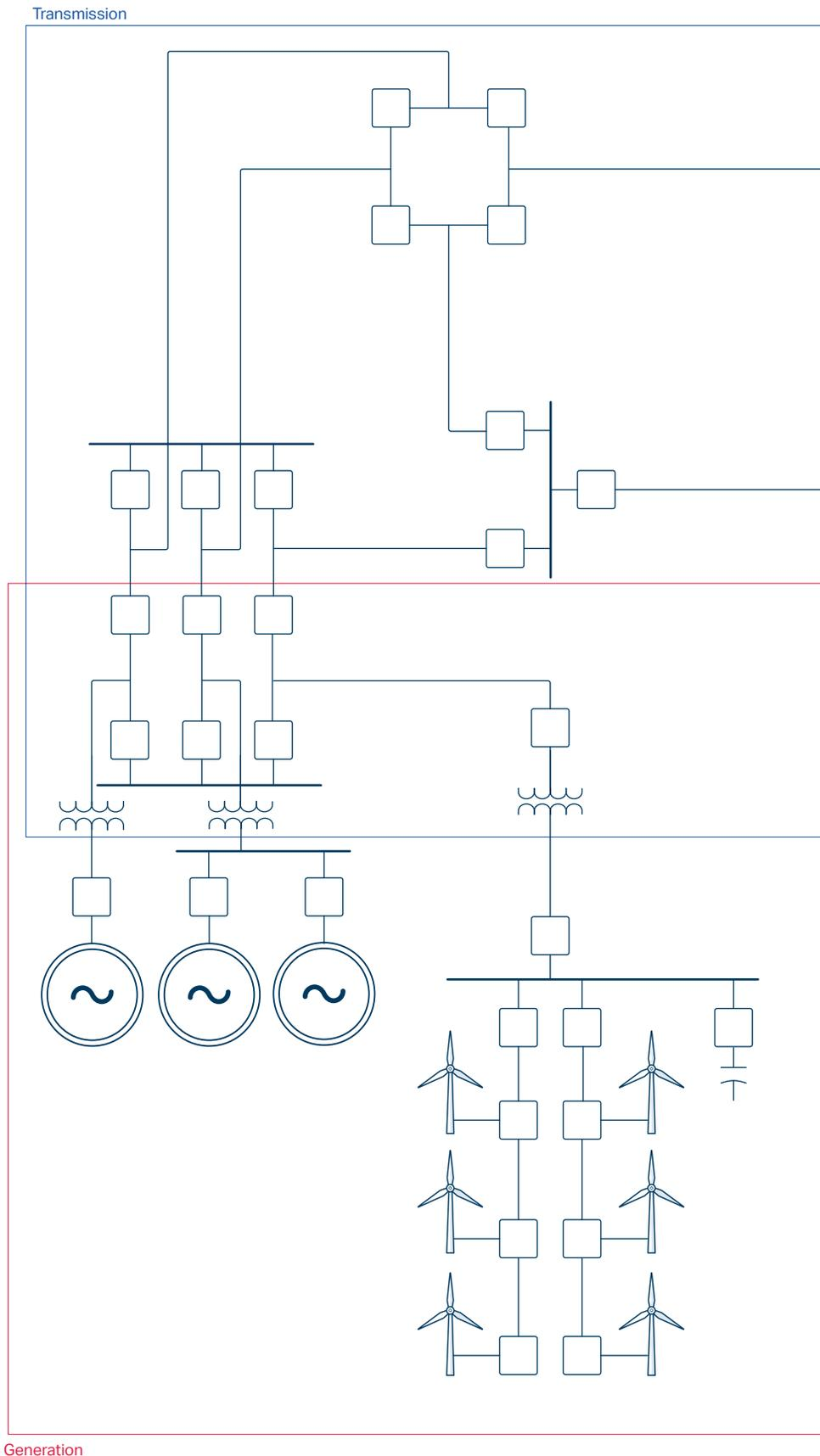

Distribution

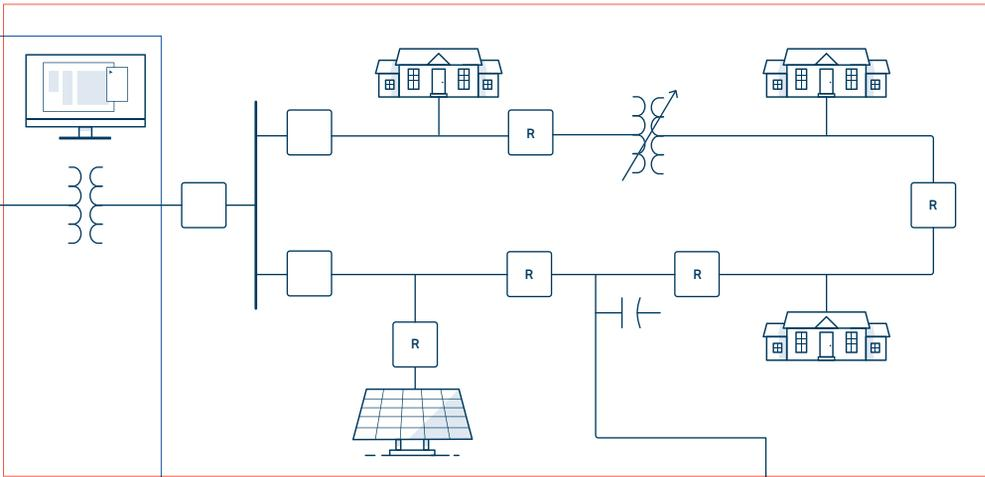

### Learn More

Visit [selinc.com/company/our-part/electric-journey](http://selinc.com/company/our-part/electric-journey) to read more about the journey of electric power.

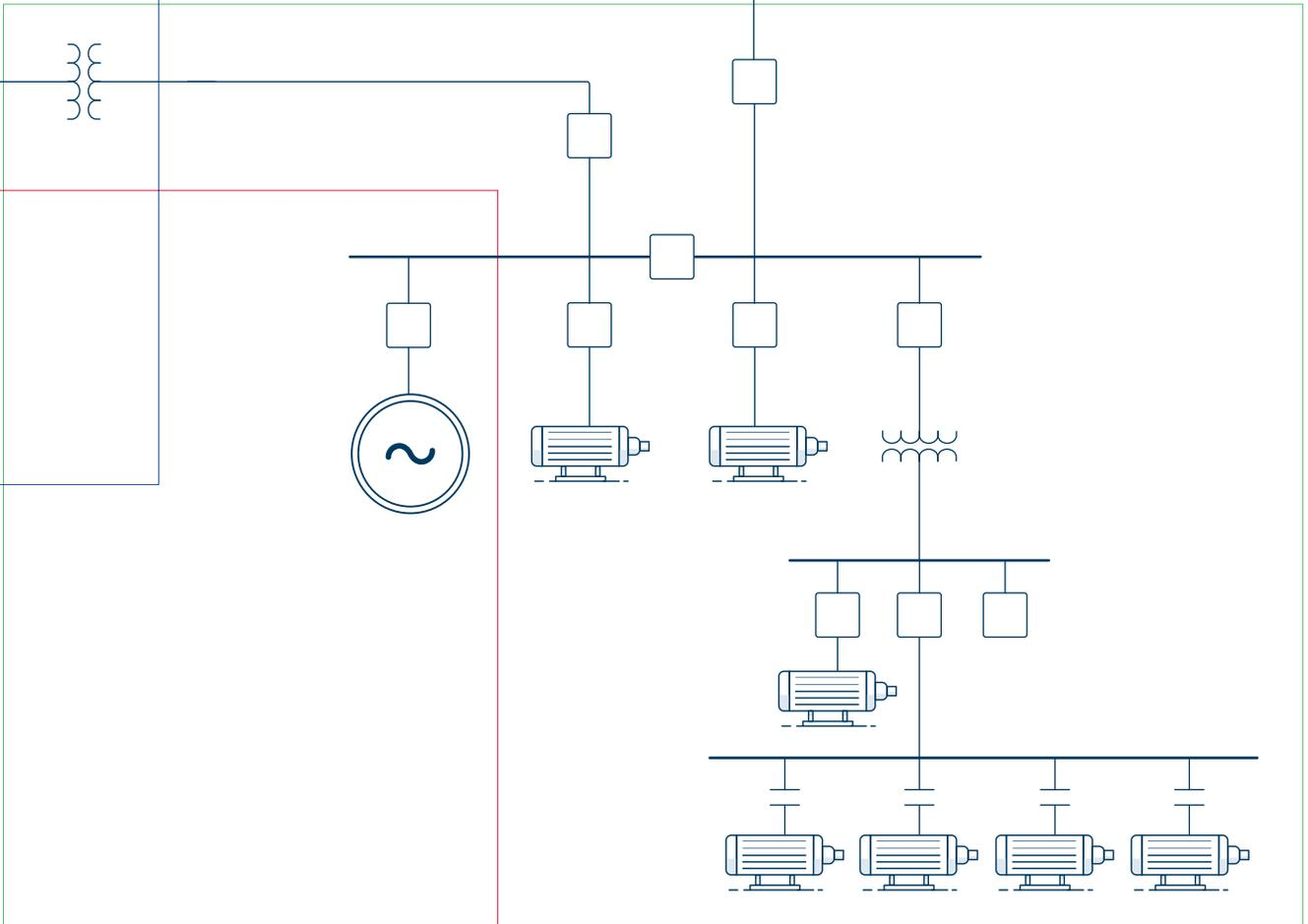

Industrial and Commercial



# SEL Network Communications

SEL offers a simple, reliable communications architecture to tie together the protection, automation, control, and monitoring devices in a power system network.

## SCADA and Operations

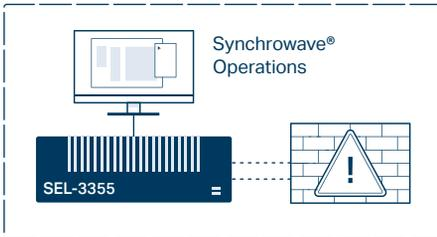

## Remote Engineering Access and Monitoring

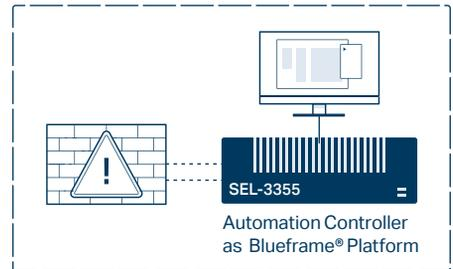

## Wide-Area Network

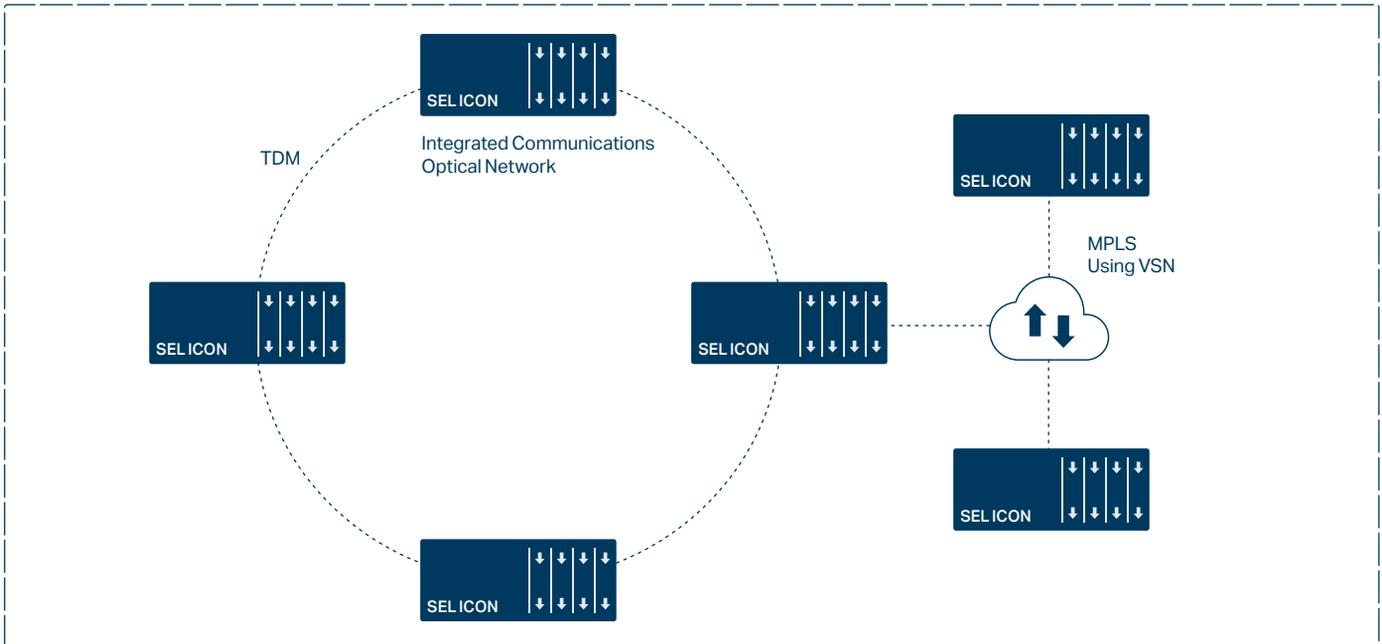

## Wireless Communications

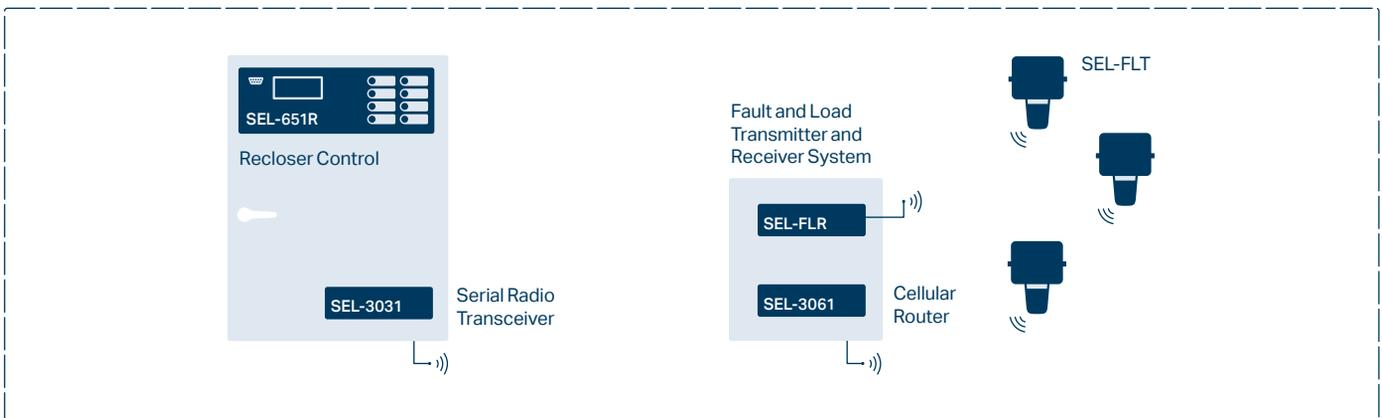

Local-Area Network

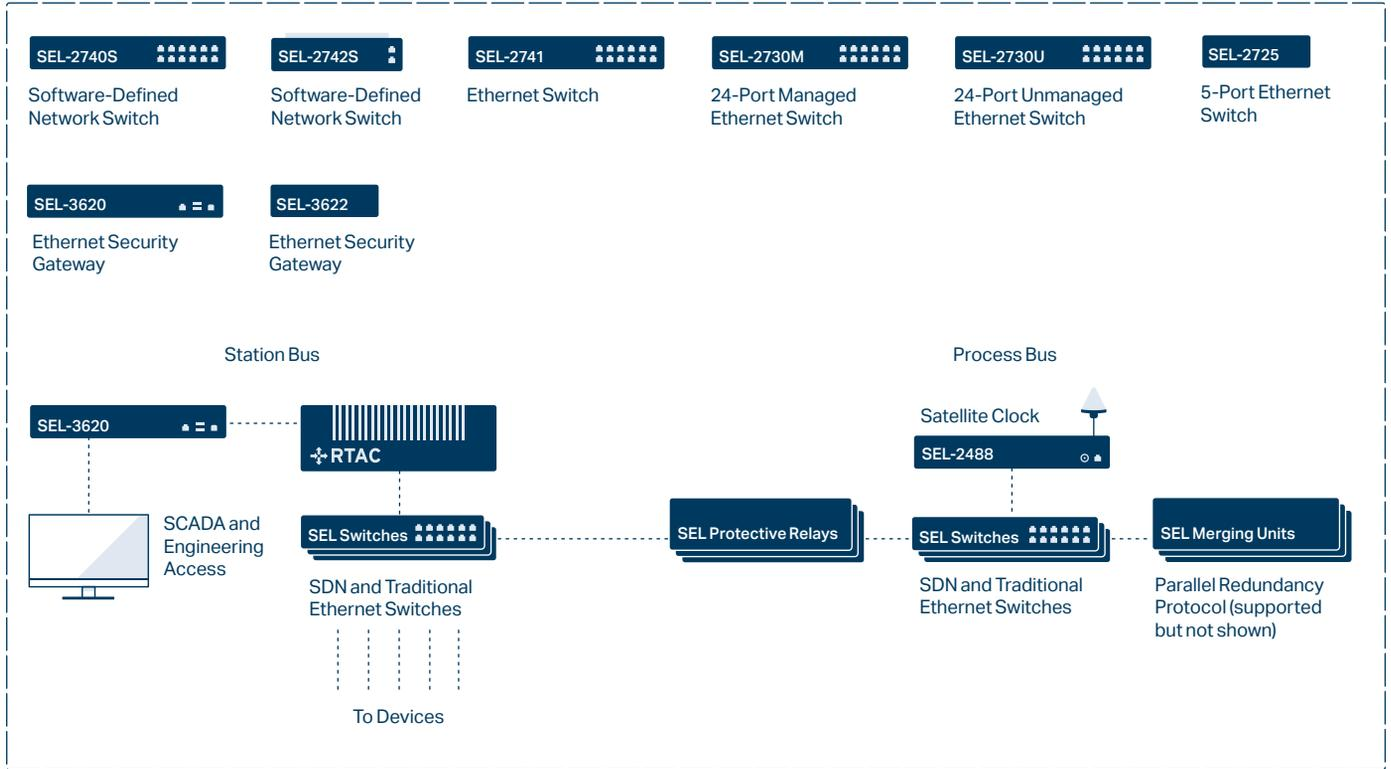

Hybrid Communications



Serial Communications

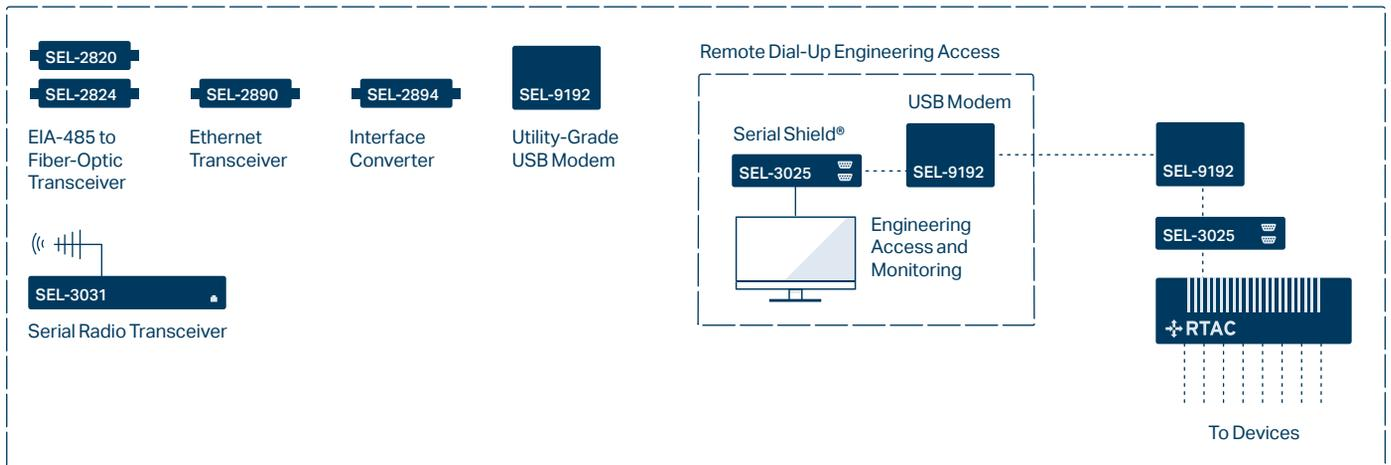



# Generator Protection

[selinc.com/solutions/generation](http://selinc.com/solutions/generation)

Modern generators and related equipment require advanced protection, automation, control, metering, and security. SEL products and solutions, including engineering services, address any nameplate rating from megawatt to kilowatt and range from wide-area protection systems down to utility-scale generation and microgrids.

## Applications

- Hydropower
- Steam and thermal generation
- Combustion and combined-cycle generation
- Wind power
- Solar power
- Nuclear
- Power management (POWERMAX®)
- Microgrids
- Remedial action schemes/ special protection systems
- Electrical balance-of-plant



## Customer Story

Belgium Integrates Offshore Wind Power Into European Grid  
[selinc.com/featured-stories/elia](http://selinc.com/featured-stories/elia)

## Example System Diagram

Combine SEL generator protection relays with other SEL automation, monitoring, and control products for a comprehensive solution.

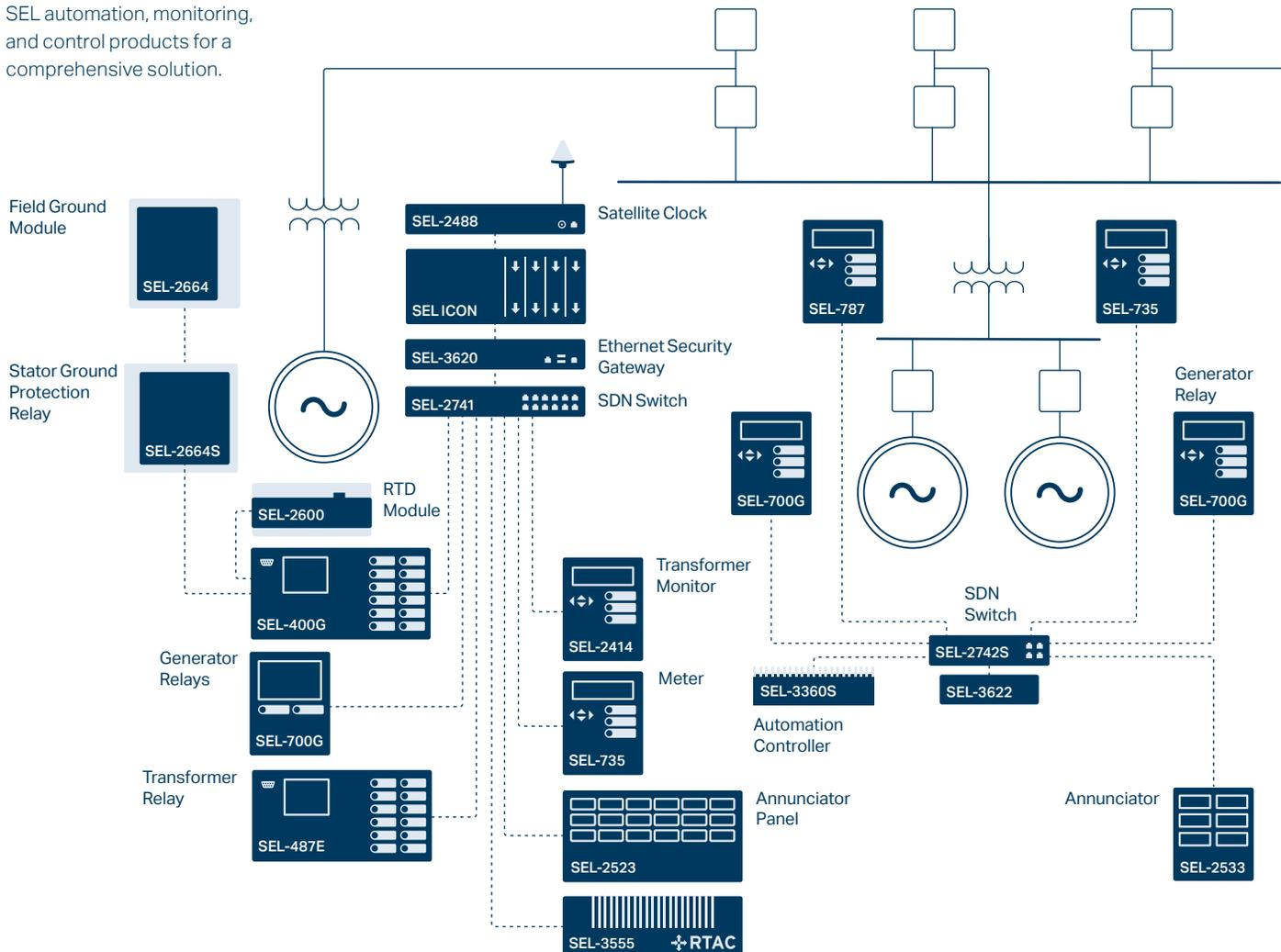

## Webinar

Protection Advancements to Benefit Generators of All Sizes and Types

[selinc.com/events/on-demand-webinar/130607](http://selinc.com/events/on-demand-webinar/130607)

## Related Material

POWERMAX Solutions

[selinc.com/api/download/106293](http://selinc.com/api/download/106293)

## Technical Papers

Wind Farm Volt/VAR Control Using a Real-Time Automation Controller

[selinc.com/api/download/99167](http://selinc.com/api/download/99167)

Leveraging Digital Relays for Protection of Pumped Storage Hydro

[selinc.com/api/download/121666](http://selinc.com/api/download/121666)

Capability Curve-Based Generator Protection Minimizes Generator Stress and Maintains Power System Stability

[selinc.com/api/download/124333](http://selinc.com/api/download/124333)

Stator Ground Protection for Multiple High-Impedance Grounded Generators Sharing a Common Bus

[selinc.com/api/download/124321](http://selinc.com/api/download/124321)

Understanding Generator Stator Ground Faults and Their Protection Schemes

[selinc.com/api/download/111667](http://selinc.com/api/download/111667)

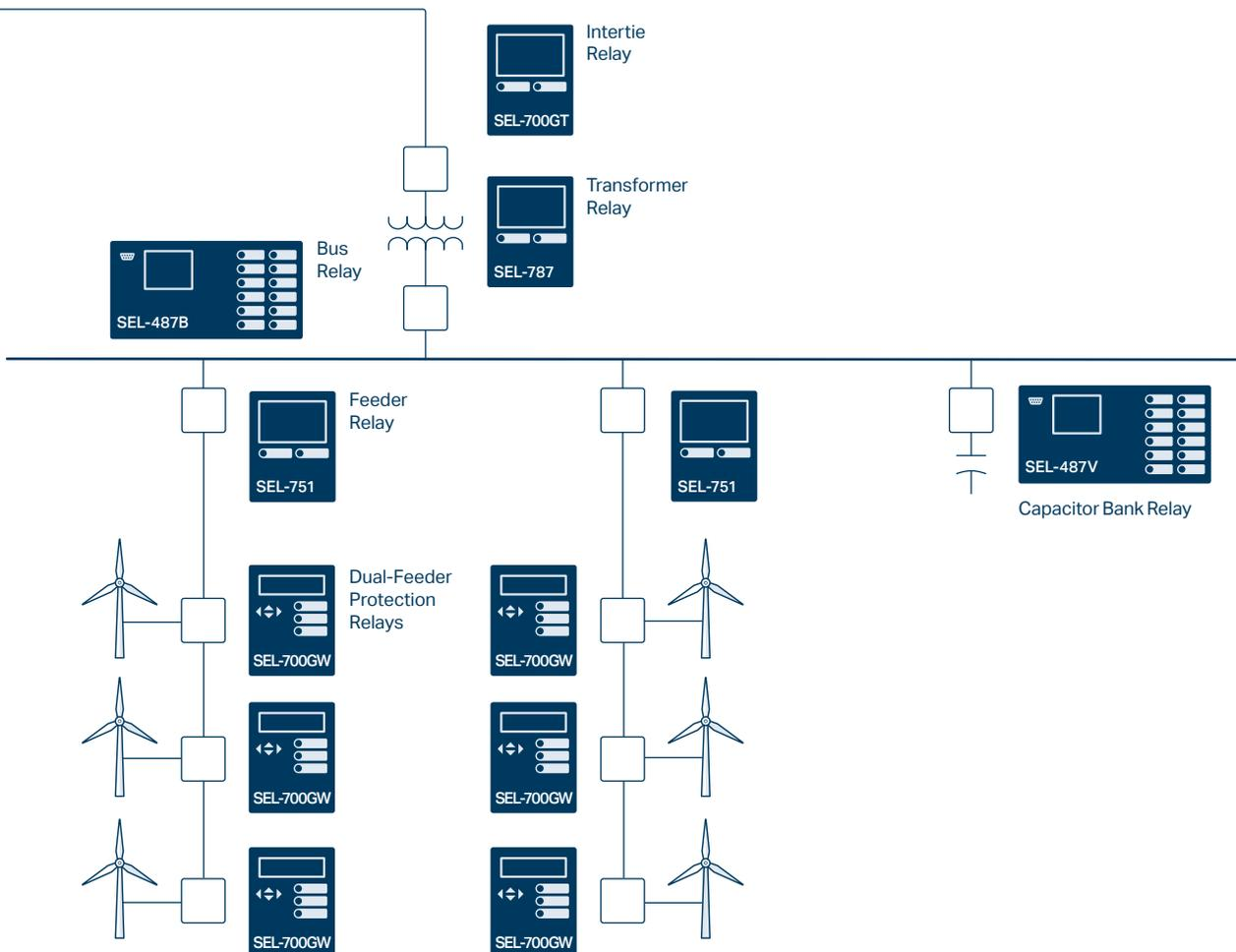



### **SEL-400G Advanced Generator Protection System**

Combine generator, bus, and step-up transformer protection in one package, and achieve complete protection for generators of all sizes and types.



### **SEL-700G Generator Protection Relay**

Provide utility and industrial generator protection with an autosynchronizer, flexible I/O, and advanced communications.



### **SEL-300G Generator Relay**

Implement primary and backup protection for utility and industrial generators to IEEE turbine protection standards.



### **SEL-2664S Stator Ground Protection Relay**

Protect high-impedance grounded generators from ground faults at standstill, during startup, and while running. All SEL-2664S relays are sold with the SEL-4664 Calibration Module.



### **SEL-2664 Field Ground Module**

Combine the SEL-2664 with other SEL generator protection devices to continuously monitor field-to-ground resistance and protect critical components, including rotor and stator windings.



### **SEL-2600 RTD Module**

Measure and transmit data from up to 12 resistance temperature detector (RTD) inputs and one contact input over a single fiber-optic link.

Applications	SEL-400G	SEL-300G	SEL-700G	SEL-700GT	SEL-700GW
Generator Protection	■	■	■	+	■ <sup>1</sup>
Unit/Overall (Generator + Generator Step-Up [GSU]) Differential Protection	■	+	■		
Independent GSU Transformer Protection	■				
Pumped-Storage Hydro Protection	■				
Integrated Synchronizer	+		+	+	
Breaker Failure Protection	■	<i>f</i>	■	■	■
Equipment Thermal Monitoring	■	+	+	+	+
Generator Intertie Protection				■	

### Instrumentation and Control

SELogic® Control Equations/Remote Control Switches	■	■	■	■	■
Nonvolatile Latch Control Switches	■	■	■	■	■
Multiple Settings Groups	■	■	■	■	■
Station Battery Monitor	■	■			
Breaker Wear Monitor	■	■	■	■	■
Event Report (Multicycle Data)/Sequential Events Recorder	■	■	■	■	■
Disturbance Recording up to 300 seconds	■				
Demand Meter	■	■	■	■	■
Load Profile Report	■		■	■	■
RTD (Resistance Temperature Detector) Inputs	+	+	+	+	+
Ethernet	+		+	+	+
Built-In Web Server	+		+	+	+
EtherNet/IP			+	+	+
IEEE 1588 Precision Time Protocol (PTP)	+		+	+	+
IEC 61850 Edition 2	+		+	+	+
IEC 60870-5-103			+	+	+
Parallel Redundancy Protocol (PRP)	+		+	+	+
DNP3 Serial	■		+	+	+
DNP3 LAN/WAN	+		+	+	+
Simple Network Time Protocol (SNTP)	+		+	+	+
Rapid Spanning Tree Protocol (RSTP)			+	+	+
Modbus TCP	+		+	+	+
Modbus RTU Outstation		■	■	■	■
IEEE C37.118 Synchrophasors (With Protocol Edition)	■ 2011		■ 2005	■ 2005	■ 2005
MIRRORED BITS® Communications	■		■	■	■

### Miscellaneous

Dual Frequency Zones (Generator and System)	■				
Frequency Tracking Range	5– 120 Hz	20– 70 Hz	15– 70 Hz	15– 70 Hz	15– 70 Hz
Accepts Wye or Open-Delta Voltage Transformers	■	■	■	■	■
Connectorized® (Quick Disconnect) Available	+	+			

Protection	SEL-400G	SEL-300G	SEL-700G	SEL-700GT	SEL-700GW
21C Compensator Distance		■	+		
21P Phase Mho Distance	■	■			
24 Overexcitation (Volts/Hertz)	■	■	■	+	
25 Synchronism Check	■	+	+	■	
27/59 Under-/Overvoltage	■	■	■	■	
27I/59I Inverse-Time Undervoltage/Overvoltage	■		■	■	
32 Directional Power	■	■	■	■	
40 Impedance-Based Loss of Field	■	■	■	+	
40 Capability-Based Loss of Field	■				
46 Current Unbalance	■	■	■	+	
46 Harmonic Current Unbalance	■				
49 Thermal Model	■		■	+	
49R Thermal Overload (RTD)	■	■	■	■	■
50 (P,N,G) Overcurrent (Phase, Neutral, Ground)	■	■	■	■	■
50Q Negative-Sequence Overcurrent	■	+	■	■	■
51 (N,G) Time Overcurrent (Neutral, Ground)	■	■	■	■	■
51 (P,Q) Time Overcurrent (Phase, Neg. Seq.)	■	■		■	■
60 Loss of Potential	■	■	■	■	
60 Voltage Balance Loss of Potential	■				
60 (P,N) Independent Split-Phase (Phase, Neutral)	■				
64G 100 Percent Stator Ground	■	■	+		
64G Intermittent Ground Fault Detection	■				
64F Field Ground	■	■	■	+	■
67 (N,G) Directional Overcurrent (Neutral, Ground)	■		■	+	
67Q Negative-Sequence Directional Overcurrent	■			■	
78 Out of Step	■	■	+		
78 Dual Zone (Generator and System) Out of Step With Pole Slip Counters	■				
78VS Vector Shift			■	■	
81 Over-/Underfrequency	■	■	■	■	
81R Rate-of-Change of Frequency	■		■	■	
87 Stator Differential	■	+	+		
Transformer Differential	■				
REF Restricted Earth Fault	■		■	+	
Inadvertent Energization	■	■	■	+	
Flashover Protection	■	<i>f</i>	<i>f</i>		

■ Standard feature + Model option *f* May be created using settings

<sup>1</sup>Protects wind collector system apparatus during overcurrent events



# Industrial and Commercial Protection

[selinc.com/solutions/industrial](http://selinc.com/solutions/industrial)

SEL power management, protection, automation, and control solutions are hard at work in heavy industries and commercial-scale facilities around the world. These solutions protect low- and medium-voltage equipment and help improve system performance, availability, and process efficiency.

## Applications

- Asynchronous (induction) and synchronous motor protection
- Variable-frequency drive protection
- Motor bus transfer systems
- Motor control centers
- Arc-flash mitigation
- Power quality and revenue metering
- Power management and control systems (POWERMAX®)
- Centralized motor management systems (MOTORMAX®)
- Microgrid control systems
- Wide-area protection and remedial action schemes



## Customer Story

Microgrid Solution Plays Big on Campus

[selinc.com/featured-stories/msu](http://selinc.com/featured-stories/msu)

## Example System Diagram

Combine SEL's low- and medium-voltage protective relays with other SEL automation, monitoring, and control products for a comprehensive solution.

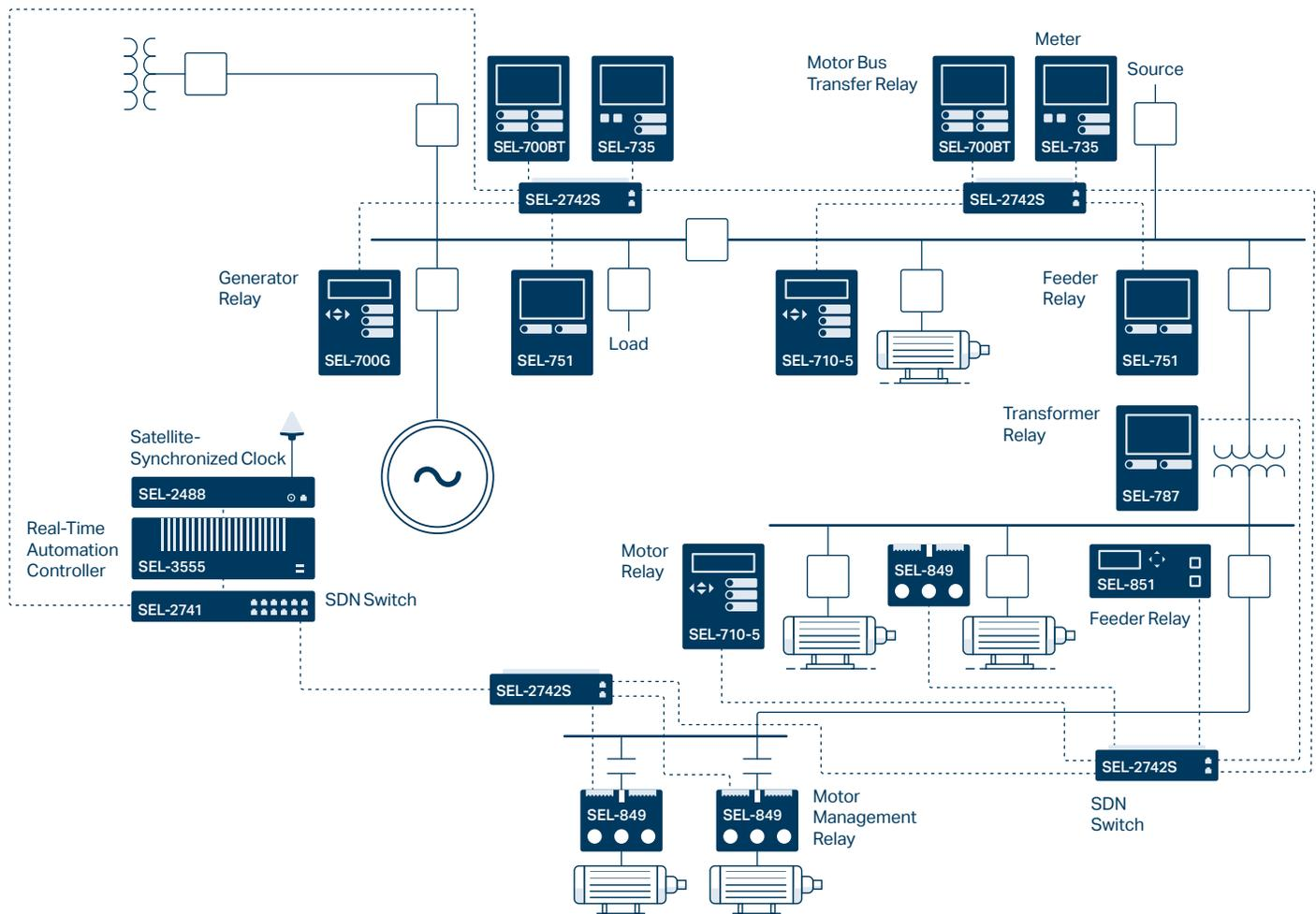

## Webinars

Improving Process Reliability With Motor Bus Transfer

[selinc.com/events/webinar/131910](http://selinc.com/events/webinar/131910)

SEL POWERMAX Commercial Microgrids—Sustainable, Economic, and Resilient

[selinc.com/events/on-demand-webinar/133374](http://selinc.com/events/on-demand-webinar/133374)

SEL POWERMAX Power Management and Control System for Industrial Applications (Part 1)

[selinc.com/events/on-demand-webinar/132490](http://selinc.com/events/on-demand-webinar/132490)

## Technical Papers

Best Practices for Motor Control Center Protection and Control

[selinc.com/api/download/102532](http://selinc.com/api/download/102532)

Case Study: Turbine Load-Sharing and Load-Shedding System for an Australian LNG Facility

[selinc.com/api/download/128554](http://selinc.com/api/download/128554)

Making My Paper Mill Safer: An Arc-Flash Energy Reduction Story

[selinc.com/api/download/126387](http://selinc.com/api/download/126387)

Case Study: Adaptive Load Shedding in Critical Industrial Facilities

[selinc.com/api/download/130119](http://selinc.com/api/download/130119)

## White Paper

Purpose-Engineered, Active-Defense Cybersecurity for Industrial Control Systems

[selinc.com/api/download/121044](http://selinc.com/api/download/121044)

## Videos

How a Data Center Achieves Utility-Grade Metering

[video.selinc.com/detail/videos/case-studies/video/5747812817001](http://video.selinc.com/detail/videos/case-studies/video/5747812817001)

Engineer a Better Network—It Starts With SDN

[video.selinc.com/detail/videos/software-defined-networking](http://video.selinc.com/detail/videos/software-defined-networking)



### SEL-751 Feeder Protection Relay

The SEL-751 offers feeder protection, an intuitive color touchscreen, fast and secure arc-flash detection, flexible I/O, and advanced communications.



### SEL-851 Feeder Protection Relay

The SEL-851 is a compact relay that provides overcurrent, voltage, and arc-flash protection as well as versatile communications.



### SEL-700BT Motor Bus Transfer Relay

Ensure motor bus system process continuity by allowing the quick transfer of load to an auxiliary feeder during primary feeder line faults.



### SEL-710-5 Motor Protection Relay

Provide protection, including optional arc-flash detection, for a full range of medium-voltage, three-phase induction, and synchronous motors.



### SEL-849 Motor Management Relay

Provide current-, voltage-, and thermal-based protection; arc-flash detection; and power metering in low-voltage to medium-voltage motor protection applications.



### SEL-700G Generator Protection Relay

Provide standby, emergency, and co-generator protection with an autosynchronizer, flexible I/O, and advanced communications.



### SEL-787-2/-3/-4 Transformer Protection Relay

Apply advanced protection and monitoring with flexible communications to two-, three-, and four-terminal transformers.



### SEL-587Z High-Impedance Differential Relay

Use the economical SEL-587Z to combine high-impedance analog technology with the advantages of microprocessor technology.



### SEL-787Z High-Impedance Differential Relay and SEL-HZM High-Impedance Module **NEW**

The SEL-787Z combines high-impedance protection principles with advanced numerical technologies to provide high-impedance differential protection. Apply the SEL-787Z and SEL-HZM High-Impedance Module for a comprehensive, single-zone bus-protection solution.



### SEL-735 Power Quality and Revenue Meter

SEL meters offer bidirectional, full four-quadrant, and high-accuracy energy metering as well as precise and reliable power quality measurements.



### SEL-2600 RTD Module

Measure and transmit data from up to 12 resistance temperature detector (RTD) inputs and one contact input over a single fiber-optic link.



### SEL-GFD Underground Ground Fault Detector

Apply the SEL-GFD over a three-phase cable bundle at ground potential in switchgear to identify faults on circuits feeding medical facilities, mining equipment, and other industrial equipment.



### SEL-3555 Real-Time Automation Controller (RTAC)

The SEL-3555 provides powerful processing for large-scale automation projects.



### SEL-3350 Computing Platform **NEW**

The SEL-3350 is ideal for limited-space, dedicated embedded applications that require midlevel I/O and computation. It can be configured as an a Real-Time Automation Controller (RTAC), as a computer, or with the SEL Blueframe® application platform.



### SEL-2742S Software-Defined Network Switch

The SEL-2742S is a 12-port, DIN-rail mount software-defined networking (SDN) switch. It combines with SEL-5056 Flow Controller software to simplify network engineering and improve LAN security.

## POWERMAX Power Management and Control Systems

For industrial facilities, an SEL POWERMAX system increases process uptime by protecting against blackouts with advanced high-speed protection and control technology. A commercial-scale POWERMAX microgrid control system helps keep the lights on, seamlessly islanding and reconnecting with the bulk electric system.

## MOTORMAX Low-Voltage Motor Management and Protection System

MOTORMAX provides comprehensive control, protection, analysis, and monitoring for original equipment manufacturer motor control centers.

Applications	SEL-751	SEL-851	SEL-700BT	SEL-710-5	SEL-849	SEL-700G	SEL-787-2/-3/-4	SEL-587Z	SEL-787Z
Generator Protection	+					■			
Motor Protection				■	■				
Motor Bus Transfer Protection			■						
Feeder Protection	■	■	■		■	+			
Transformer Protection							■		
Bus Differential Protection							■	■	■

### Protection

24 Overexcitation (Volts/Hertz)						■	+		
27/59 Under-/Overvoltage	+	+	■	■	+	■	+		■
32 Directional Power	+	+			+	■	+		
37 Underpower				■	+				
46 Current Unbalance			■	■	■	■			
47 Phase Reversal				■	■				
49 Thermal	■			■	■	■	■		
49R Thermal Overload (Resistance Temperature Detector [RTD])	+		■	+		■			
50 Overcurrent	■	■	■	■	■	■	+	■	■
51 Time Overcurrent	■	■	■	■	■	■	+	■	■
55 Power Factor	+	+		■	+	<i>f</i>			
60 Loss of Potential	+	+	■	■	+	■			
64F Field Ground						■			
67 (N,G) Directional Overcurrent (Neutral, Ground)	+		■			■			
81 Over-/Underfrequency	+	+	■	■	+	■	+		
87 Current Differential				+		+	■		

Protection, Continued	SEL-751	SEL-851	SEL-700BT	SEL-710-5	SEL-849	SEL-700G	SEL-787-2/-3/-4	SEL-587Z	SEL-787Z
87Z High-Impedance Differential								■	■
REF Restricted Earth Fault						■	+		
Arc-Flash Detection	+	+		+	■				+
Separate Neutral Overcurrent	■	■	■	■	■	■	+		
Broken Rotor Bar Detection				■					
Low-Energy Analog (LEA) Current and Voltage Sensors Support	+								

### Instrumentation and Control

Breaker Wear Monitoring	■		■	■		■	■		
RTD Inputs	+		+	+		+	+		
IEC 61850 Edition 2	+	+	+	+		+	+		+
Parallel Redundancy Protocol (PRP)	+		+	+	■	+	+		+
DNP3 Serial	+	+	+	+	+	+	+		+
DNP3 LAN/WAN	+	+	+	+	+	+	+		+
Simple Network Time Protocol (SNTP)	+	■	+	+	■	+	+		+
Built-In Web Server	■	■	■	+	■	+	■		■
IEEE 1588 Precision Time Protocol (PTP)	+		+	+		+	+		+
EtherNet/IP	+		+	+	+	+	+		+
Modbus TCP	+	■	+	+	+	+	+	■	+
Modbus RTU Outstation	■	■	■	■	■	■	■	■	■
Rapid Spanning Tree Protocol (RSTP)	+		+	+		+	+		+

■ Standard feature    + Model option    *f* May be created using settings



# Transmission Protection

[selinc.com/solutions/transmission](http://selinc.com/solutions/transmission)

SEL transmission line protective relays provide reliable subcycle line current differential and multizone distance protection. Their fault-locating capabilities allow you to efficiently dispatch line crews to quickly isolate line problems and restore service faster.

## Applications

- Directional and/or distance pilot protection
- Differential protection
- Time-domain line protection
- Step distance protection
- Single-pole tripping
- Series-compensated lines
- Dual-breaker terminals
- Bay control and substation integration



## Customer Stories

Lighting up the Desert Nation

[selinc.com/highlights/toua](http://selinc.com/highlights/toua)

## Example System Diagram

Combine SEL transmission protective relays with other SEL automation, monitoring, and control products for a comprehensive solution.

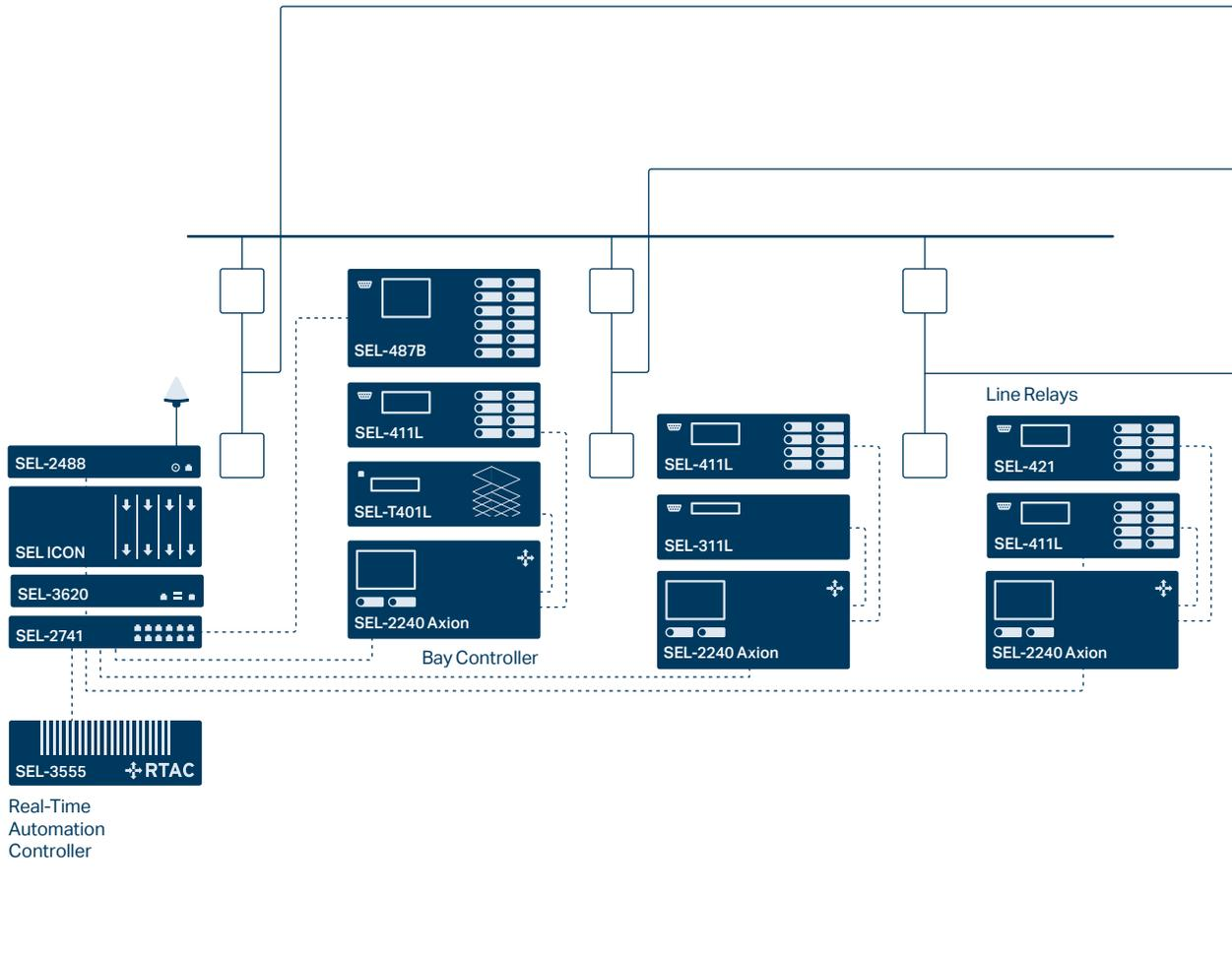

## Webinars

Detecting and Locating a Broken Conductor Before It Converts Into a Fault

[selinc.com/events/on-demand-webinar/136022](http://selinc.com/events/on-demand-webinar/136022)

## Technical Papers

Modern Line Current Differential Protection Solutions

[selinc.com/api/download/6390](http://selinc.com/api/download/6390)

Transmission Line Protection System for Increasing Power System Requirements

[selinc.com/api/download/2603](http://selinc.com/api/download/2603)

A Fresh Look at Limits to the Sensitivity of Line Protection

[selinc.com/api/download/8505](http://selinc.com/api/download/8505)

Series Compensation, Power Swings, and Inverter-Based Sources and Their Impact on Line Current Differential Protection

[selinc.com/api/download/21474837052](http://selinc.com/api/download/21474837052)

Speed of Line Protection – Can We Break Free of Phasor Limitations?

[selinc.com/api/download/106193](http://selinc.com/api/download/106193)

## Real-World Event Reports

Field Experiences With Traveling-Wave Protection and Fault Locating

[selinc.com/mktg/122973](http://selinc.com/mktg/122973)

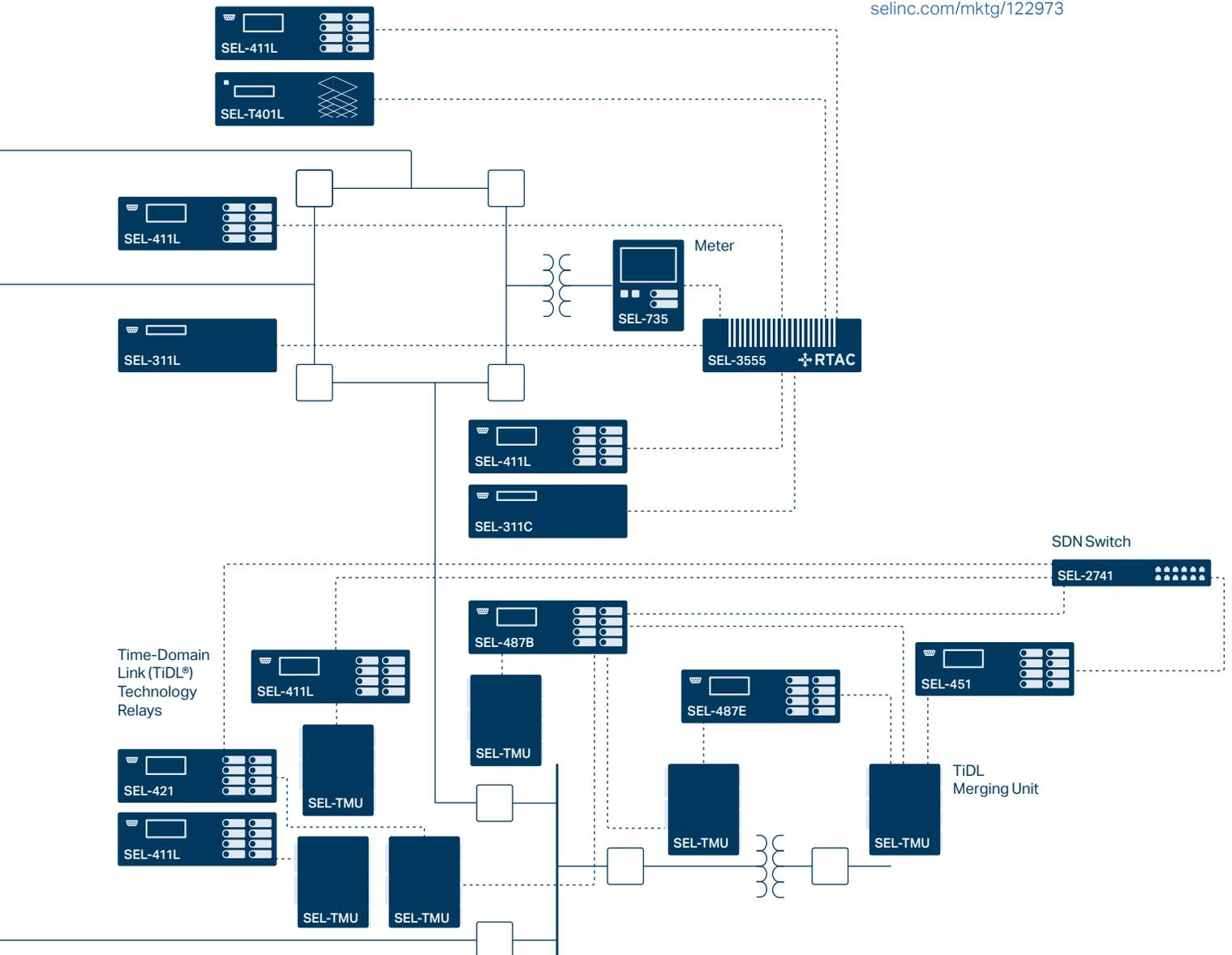



### SEL-T401L Ultra-High-Speed Line Relay

Apply the SEL-T401L, which was built on the field experience of the SEL-T400L, for its unprecedented operating speed and complete suite of primary and backup line protection functions. Use the SEL-T401L as a redundant protection system with other SEL relays without concerns for common-mode failures.



### SEL-T400L Time-Domain Line Protection

Apply the SEL-T400L for ultra-high-speed protection of transmission lines. With breakthrough traveling-wave and incremental-quantity technologies, the SEL-T400L trips in as fast as 1 ms, records events with a 1 MHz sampling rate, and locates faults to the nearest tower.



### SEL-411L Advanced Line Differential Protection, Automation, and Control System

Apply the SEL-411L for subcycle single- or three-pole line current differential, distance, and directional overcurrent protection. Optional traveling-wave fault locating pinpoints faults to the nearest tower span. Broken conductor detection logic can identify line breaks on overhead conductors.



### SEL-421 Protection, Automation, and Control System

Employ the SEL-421 for distance and directional protection and control of a two-breaker bay.



### SEL-311L Line Current Differential Protection and Automation System

Use the SEL-311L for comprehensive, easy-to-apply line differential and four-zone distance protection.



### SEL-311C Transmission Protection System

Apply the SEL-311C-1 for three-pole distance protection, reclosing, monitoring, and control of breakers on transmission lines. Apply the SEL-311C-2/-3 for single-pole tripping.



### SEL-387L Line Current Differential Relay

Use the SEL-387L for easy-to-apply line differential protection with zero settings.



### SEL-T4287 Traveling-Wave Test System

Test traveling-wave fault locators and line protective relays (e.g., the SEL-T400L, SEL-T401L, and SEL-411L) using the SEL-T4287, a simple and compact secondary pulse injection test set.

Applications	SEL-T401L	SEL-411L	SEL-421	SEL-311C	SEL-311L	SEL-387L	SEL-T400L
Distance Protection	■	■	■	■	■		■
Line Current Differential		■			■	■	
Breaker Failure Protection	<i>f</i>	■	■	■	<i>f</i>		
Undervoltage Load Shedding	<i>f</i>	<i>f</i>	<i>f</i>	<i>f</i>	<i>f</i>		
Series-Compensated Lines	■	+	+				■

### Protection

Subcycle Distance Elements	■	+	+	+			■
21G Mho Ground Distance	■	■	■	■	■		
21G Quad Ground Distance	■	■	■	■	■		
21P Mho Phase Distance	■	■	■	■	■		
21P Quad Phase Distance	■	■	■				
TD21 Incremental-Quantity Distance (Phase and Ground)	■						■
TD32 Incremental-Quantity Directional	■						■
TW32 Traveling-Wave Directional	■						■
TW87 Traveling-Wave Differential	■						■
87L Line Current Differential		■			■	■	
25 Synchronism Check		■	■	■	■		
27/59 Under-/Overvoltage	■	■	■	■	■		
49 Thermal		■	■				
50 (N,G) Overcurrent (Neutral, Ground)	■	■	■	■	■		
50P Phase Overcurrent	■	■	■	■	■		
50Q Negative-Sequence Overcurrent	■	■	■	■	■		
51 (N,G) Time Overcurrent (Neutral, Ground)	■	■	■	■	■		
51P Phase Time Overcurrent	■	■	■	■	■		
51Q Negative-Sequence Time Overcurrent	■	■	■	■	■		
67 (N,G) Directional Overcurrent (Neutral, Ground)	■	■	■	■	■		
67P Phase Directional Overcurrent	■	■	■	■	■		
67Q Negative-Sequence Directional Overcurrent	■	■	■	■	■		
81 Under-/Overfrequency		■	■	■	■		
Programmable Analog Math		■	■				
Out-of-Step Block and Trip	■	■	■	■	■		
Load-Encroachment Supervision	■	■	■	■	■		
Switch-Onto-Fault	■	■	■	■	■		
Single-Pole Trip	■	■	■	+	+		■
Zone/Level Timers	■	■	■	■	■		
Pilot Protection Logic	■	■	■	■	■		■

Instrumentation and Control	SEL-T401L	SEL-411L	SEL-421	SEL-311C	SEL-311L	SEL-387L	SEL-T400L
79 Automatic Reclosing		■	■	■	■		
Number of Controlled Breakers	2	2	2	1	1	1	2
Fault Locating	■	■	■	■	■		■
Single-Ended Traveling-Wave Fault Locating	■						■
Double-Ended Traveling-Wave Fault Locating	■	+					■
Adaptive Autoreclose Cancel Logic for Hybrid Lines	■						■
Line Monitor	■						■
Broken Conductor Detection		+					
SELogic® Control Equations	■	■	■	■	■		
Nonvolatile Latch Control Switches	■	■	■	■	■		
SELogic Remote Control Switches	■	■	■	■	■		
SELogic Local Control Switches	■	■	■	■	■		
Display Points		■	■	■	■		
MIRRORED BITS® Communications	■	■	■	■	■		■
Substation Battery Monitor		■	■	■	■	■	
Breaker Wear Monitor		■	■	■	■		
Trip Coil Monitor	<i>f</i>	<i>f</i>	<i>f</i>	<i>f</i>	<i>f</i>		
Event Records (Multicycle Data)	■	■	■	■	■	■	■
1 MHz Sampling Event Records	■						■
Sequential Events Recorder	■	■	■	■	■	■	■
Instantaneous Metering	■	■	■	■	■	■	■
DNP3 Level 2 Outstation	■	■	■	■	+	+	■
Parallel Redundancy Protocol (PRP)		■	■	+			
IEEE 1588 Precision Time Protocol Version 2 (PTPv2)		+	+				
IEC 61850-9-2 Sampled Values Technology		+	+				
Time-Domain Link (TiDL®) Technology		+	+				
IEC 61850 Communications		+	+	+	+		
Synchrophasors		■	■	■	■		
Built-In Event Playback Testing	■						■
SEL Fast Time-Domain Values	■						■

### Miscellaneous

Accepts Delta Voltage Transformers			+	■			
Connectorized® (Quick Disconnect) Available		+	+	+		+	
Configurable Labels		■	+	+			
Custom Labels	■						■

■ Standard feature    + Model option    *f* May be created using settings



# Substation Protection

[selinc.com/products/transmission/protection](https://selinc.com/products/transmission/protection) | [selinc.com/products/distribution/protection](https://selinc.com/products/distribution/protection)

SEL devices protect, monitor, and control critical assets located in all types of generation, transmission, and distribution substations.

## Applications

- Transformer protection and monitoring
- Bus protection
- Breaker failure protection
- Capacitor bank protection
- Digital secondary systems that use Time-Domain Link (TiDL®) or IEC 61850 technologies

## Webinars

Innovation in IEC 61850 Digital Secondary Systems

[selinc.com/events/on-demand-webinar/137779](https://selinc.com/events/on-demand-webinar/137779)

## Technical Papers

Considerations for Using High-Impedance or Low-Impedance Relays for Bus Differential Protection

[selinc.com/api/download/5562](https://selinc.com/api/download/5562)

Beyond the Nameplate: Transformer Compensation Revisited—New Applications, Greater Simplicity

[selinc.com/api/download/138123](https://selinc.com/api/download/138123)

Performance of IEC 61850 Sampled Values Relays for a Real-World Fault

[selinc.com/api/download/137357](https://selinc.com/api/download/137357)

Redundant Bus Protection Using High-Impedance Differential Relays

[selinc.com/api/download/121745](https://selinc.com/api/download/121745)

Principles of Shunt Capacitor Bank Application and Protection

[selinc.com/api/download/6395](https://selinc.com/api/download/6395)



## Customer Stories

Caribbean Utility Thwarts Island-Wide Power Outages

[selinc.com/featured-stories/cuc](https://selinc.com/featured-stories/cuc)

Busbar Protection Made Simpler and Safer With Innovative TiDL Technology

[selinc.com/solutions/success-stories/enel](https://selinc.com/solutions/success-stories/enel)

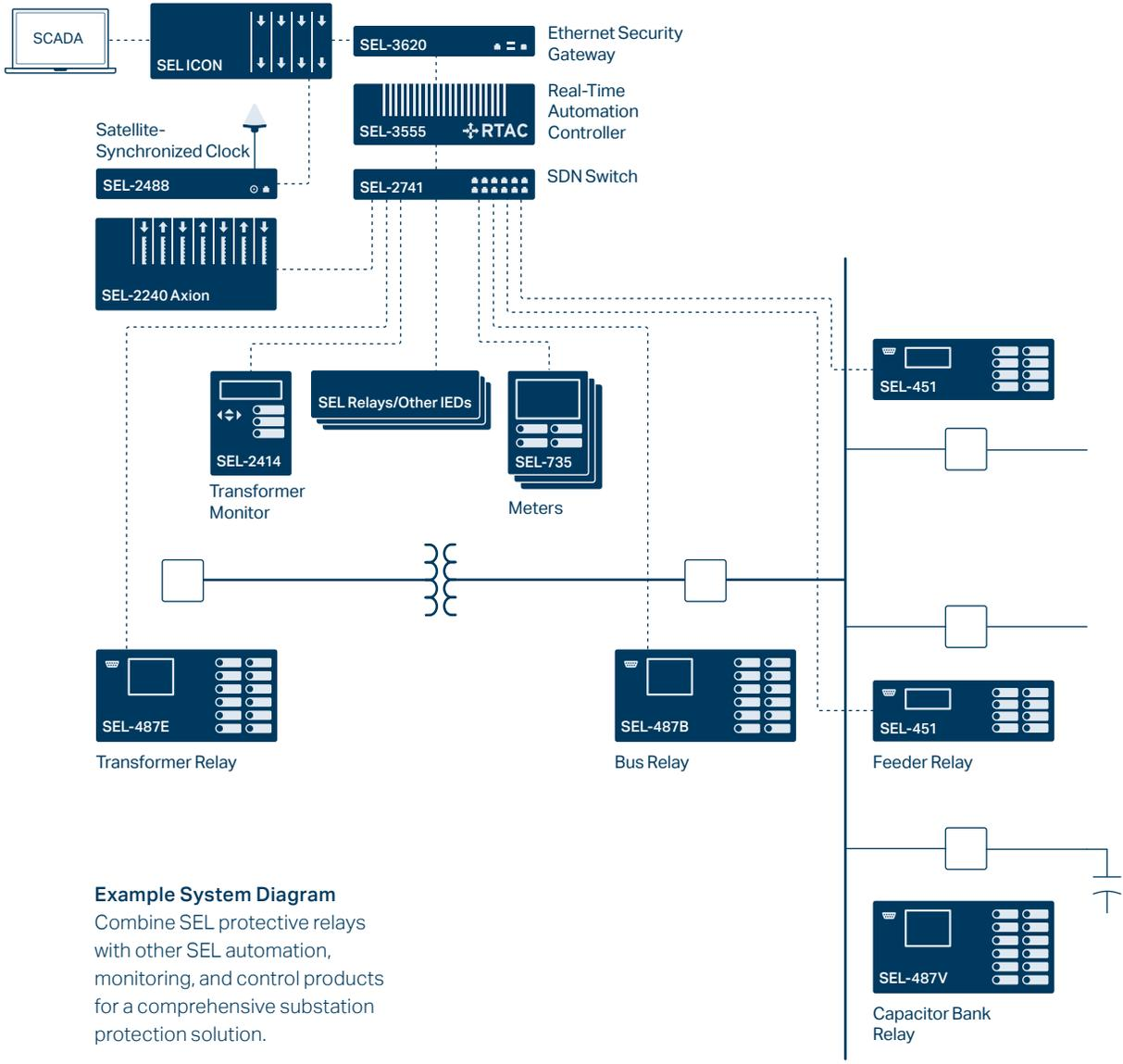

**Example System Diagram**  
 Combine SEL protective relays with other SEL automation, monitoring, and control products for a comprehensive substation protection solution.



### SEL-787-2/-3/-4 Transformer Protection Relay

Apply advanced protection and monitoring with flexible communications to two-, three-, and four-terminal transformers.



### SEL-TMU TiDL Merging Unit

Employ the SEL-TMU for remote data acquisition in substations with Time-Domain Link (TiDL) technology systems. It can share data with up to four SEL-400 series TiDL relays.



### SEL-401 or SEL-421 Protection, Automation, and Control Merging Units

Apply these merging units in substations with IEC 61850-9-2 Sampled Values (SV) systems. The SEL-401 is a standalone merging unit with phase overcurrent and breaker failure protection. The SEL-421 provides complete line protection, including five zones of subcycle mho and quadrilateral distance elements.



### SEL-487V Capacitor Protection and Control System

Protect and control grounded and ungrounded, single- and double-wye capacitor bank configurations.



### SEL-487E Transformer Protection Relay

Provide high-speed transformer differential protection for up to five terminals as well as advanced monitoring, metering, automation, and control.



### SEL-2414 Transformer Monitor

Provide standalone or distributed monitoring and control for new and existing transformers. Soon, the SEL-2414 will be available with a color touchscreen display.



### SEL-487B Bus Differential and Breaker Failure Relay

Provide bus differential and breaker failure protection, automation, and control in applications with up to seven terminals per relay.



### SEL-787Z High-Impedance Differential Relay and SEL-HZM High-Impedance Module **NEW**

The SEL-787Z combines high-impedance protection principles with advanced numerical technologies to provide high-impedance differential protection. Apply the SEL-787Z and SEL-HZM High-Impedance Module for a comprehensive, single-zone bus-protection solution.



### SEL-352 Breaker Failure Relay

Provide breaker failure protection and breaker control and monitoring with unparalleled flexibility.

## Transformer Protection and Monitoring

Applications	SEL-487E	SEL-387E	SEL-387	SEL-387A	SEL-787	SEL-787-2X/-21/-2E	SEL-787-3E/-3S/-4X	SEL-587	SEL-2414
Breaker Failure Protection	■	f	f	f	■	■	■	f	f
Transformer and Machine Current Differential	■	■	■	■	■	■	■	■	
Low-Impedance Bus Differential	■	■	■		■	■	■		
Underfrequency Load Shedding	■	f			+	+	+		
Undervoltage Load Shedding	■	f			+	+	+		
Three-Phase Current Inputs	5	3	4	2	2	2*	3 or 4	2	3*
Three-Phase Voltage Inputs	2	1			1*	1*	1*		1*

## Protection

24 Overexcitation (Volts/Hertz)	■	■			+	+	+		
25 Synchronism Check	■						+		
27/59 Under-/Overvoltage	■	■			+	+	+		
32 Directional Power	■				+	+	+		
46 Current Unbalance	■								
49 Equipment Thermal Monitoring	■		+	■	■	■	■		
50FO Flashover Protection	f	f			f	f	f		
50 (N,G) Overcurrent (Neutral, Ground)	■	■	■	■	■	■	■	■	
50P Phase Overcurrent, 50Q Negative-Sequence Overcurrent	■	■	■	■	■	■	■	■	
51 (N,G) Time Overcurrent (Neutral, Ground)	■	■	■	■	■	■	■	■	
51P Phase Time Overcurrent	■	■	■	■	■	■	■	■	
51Q Negative-Sequence Time Overcurrent	■	■	■	■	■	■	■	■	
67 (P,G,Q) Directional Overcurrent (Phase, Ground, Negative Sequence)	■								
81 Under-/Overfrequency	■	■			+	+	+		
81R Rate-of-Change of Frequency	f								
87 Current Differential	■	■	■	■	■	■	■	■	
REF Restricted Earth Fault	■	■	■	+	+	+	■		

## Instrumentation and Control

Instrumentation and Control	SEL-487E	SEL-387E	SEL-387	SEL-387A	SEL-787	SEL-787-2X/-21/-2E	SEL-787-3E/-3S/-4X	SEL-587	SEL-2414
SELogic® Control Equations	■	■	■	■	■	■	■	■	■
Voltage Check on Closing	f	f			f	f	f		
Transformer Cooling Fan Control	f				f	f	f		■
Nonvolatile Latch Control Switches	■	■	■	■	■	■	■		■
SELogic Remote Control Switches	■	■	■	■	■	■	■	■	■
SELogic Local Control Switches	■	■	■	■	■	■	■		■
Display Points	■	■	■	■	■	■	■		■
Multiple Settings Groups	■	■	■	■	■	■	■		
Substation Battery Monitor	■	■	■	■		+	+		f
Breaker Wear Monitor	■	■	■	■		■	■		
Event Report (Multicycle Data)	■	■	■	■	■	■	■	■	■
Sequential Events Recorder	■	■	■	■	■	■	■		■
Instantaneous and Demand Meter	■	■	■	■	■	■	■	■	■
Load and Temperature Profile Report	■				■	■	■		■
RTD (Resistance Temperature Detector) Inputs						+	+	+	+
Built-In Web Server	■	■				+	+		
Software-Invertible Polarities	■								
IEC 60255-Compliant Thermal Model	■								
IEEE C37.118 Synchrophasors	■				■	■	■		
IEC 61850	+	+			+	+	+		+
IEC 61850-9-2 Sampled Values Technology	+								
Simple Network Time Protocol (SNTP)	■				+	+	+		
Parallel Redundancy Protocol (PRP)	■					+	+		
IEEE 1588 Precision Time Protocol Version 2 (PTPv2)	+					+	+		
EtherNet/IP						+	+		
Time-Domain Link (TiDL) Technology	+								
Through-Fault Monitor	■	■	+	■	■	■	■		■
Thermal Model/SEL-2600 RTD Module Communications	■		+	■	■	■	■		■

■ Standard feature + Model option

f May be created using relay elements, device word bits, analog quantities, and timers

## Bus Protection

Applications	SEL-387	SEL-487B	SEL-487E	SEL-787Z
Breaker Failure Protection	<i>f</i>	■	■	■
Bus Differential	<i>f</i>	■	■	■
Transformer and Machine Current Differential	■		■	
High-Impedance Bus Differential				■
Low-Impedance Bus Differential	■	■	■	
Three-Phase Current Inputs	4	7/10/21 <sup>1</sup>	5	4
Three-Phase Voltage Inputs		1	2	3

### Protection

27/59 Under-/Overvoltage		■	■	■
46 Current Unbalance		<i>f</i>	■	
47 Voltage Unbalance			<i>f</i>	
50 (N,G) Overcurrent (Neutral, Ground)	■		■	■
50P Phase Overcurrent	■	■	■	■
50Q Negative-Sequence Overcurrent	■		■	■
51 (N,G) Time Overcurrent (Neutral, Ground)	■		■	■
51P Phase Time Overcurrent	■	■	■	■
51Q Negative-Sequence Time Overcurrent	■		■	■
87 Current Differential	■	■	■	
87Z High-Impedance Differential				■
Single-Pole Trip/Close		■		
Three-Phase Differential Bus Zones	1	2/3/6 <sup>1</sup>	1	1
Check Zones		3		

Instrumentation and Control	SEL-387	SEL-487B	SEL-487E	SEL-787Z
79 Automatic Reclosing		<i>f</i>	<i>f</i>	
Dynamic Zone Selection		■		
SELogic Control Equations	■	■	■	■
Nonvolatile Latch Control Switches	■	■	■	■
SELogic Remote/Local Control Switches	■	■	■	■
Display Points	■	■	■	■
Multiple Settings Groups	■	■	■	■
Substation Battery Monitor	■	■	■	
Breaker Wear Monitor	■		■	
Event Report (Multicycle Data)	■	■	■	■
Sequential Events Recorder	■	■	■	■
Instantaneous Meter	■	■	■	■
Demand Meter	■		■	
Through-Fault Monitor	■		■	
Software-Invertible Polarities			■	
IEC 60255-Compliant Thermal Model			■	
IEEE C37.118 Synchrophasors			■	
Synchrophasor Real-Time Control			■	
IEC 61850		+	+	+
IEC 61850-9-2 Sampled Values Technology		+	+	
Built-In Web Server		■	■	■
Simple Network Time Protocol (SNTP)		■	■	■
MIRRORED BITS® Communications		■	■	■
Parallel Redundancy Protocol (PRP)		■	■	■
IEEE 1588 Precision Time Protocol Version 2 (PTPv2)		+	+	+
Time-Domain Link (TiDL) Technology		+	+	

### Miscellaneous Features

Connectorized® (Quick Disconnect) Available	+	+	+	
---	---	---	---	--

■ Standard feature    + Model option    <sup>1</sup>1/2/3 relay application

*f* May be created using settings

## Breaker Failure and Capacitor Bank Protection

Applications	SEL-352	SEL-451	SEL-487B	SEL-487V
Breaker Failure Protection, Number of Three-Phase Breakers	1	2	7	1
Bus Differential			■	
Shunt Capacitor Bank Protection		<i>f</i>		■
Underfrequency Load Shedding		<i>f</i>		<i>f</i>
Undervoltage Load Shedding	<i>f</i>	<i>f</i>	<i>f</i>	<i>f</i>

### Protection

25 Synchronism Check	■	■		
27/59 Under-/Overvoltage	■	■	■	■
32/37 Power Elements	■	<i>f</i>	<i>f</i>	■
46 Current Unbalance	■	<i>f</i>	<i>f</i>	■
47 Voltage Unbalance		<i>f</i>	<i>f</i>	<i>f</i>
49 Equipment Thermal Monitoring	+	<i>f</i>		<i>f</i>
50FO Flashover Protection	■	■		■
50 (N,G) Overcurrent (Neutral, Ground)	■	■		■
50P Phase Overcurrent	■	■	■	■
50Q Negative-Sequence Time Overcurrent		■		■
51 (N,G) Time Overcurrent (Neutral, Ground)		■		■
51P Phase Time Overcurrent		■	■	■
51Q Negative-Sequence Time Overcurrent		■		■
60 (N,P) Current Unbalance (Neutral, Phase)				■
67 Directional Overcurrent		■		■
81 Under-/Overfrequency		■		■
81R Rate-of-Change of Frequency				■
87 Current Differential			■	
87V Voltage Differential	■	<i>f</i>		■
Single-Pole Trip/Close	■		■	

Instrumentation and Control	SEL-352	SEL-451	SEL-487B	SEL-487V
Open-Pole Detection		<i>f</i>	<i>f</i>	■
79 Automatic Reclosing	<i>f</i>	■	<i>f</i>	<i>f</i>
SELogic Control Equations	■	■	■	■
Voltage Check on Closing		■		
Nonvolatile Latch Control Switches	■	■	■	■
SELogic Remote/Local Control Switches	■	■	■	■
Display Points	■	■	■	■
Multiple Settings Groups	■	■	■	■
Substation Battery Monitor	+	■	■	■
Breaker Wear Monitor	+	■		■
Voltage Sag, Swell, and Interruption (VSSI) Recording		■		■
Event Report (Multicycle Data)	■	■	■	■
Sequential Events Recorder	■	■	■	■
Instantaneous Meter	■	■	■	■
Demand Meter		■		■
Harmonic Metering				■
Software-Invertible Polarities		■		
IEC 60255-Compliant Thermal Model		■		
IEEE C37.118 Synchrophasors		■		■
IEC 61850		+	+	+
IEC 61850-9-2 Sampled Values Technology		+	+	
Built-In Web Server		■	■	■
Simple Network Time Protocol (SNTP)		■	■	■
Parallel Redundancy Protocol (PRP)		■	■	■
IEEE 1588 Precision Time Protocol Version 2 (PTPv2)		+	+	
Time-Domain Link (TiDL) Technology		+	+	
SEL-2600 RTD Module Communications	+	■		■

### Miscellaneous Features

Connectorized (Quick Disconnect) Available	+	+	+	+
Synchrophasor Real-Time Control		■		■

■ Standard feature    + Model option

*f* May be created using relay elements and timers



# Distribution Protection and Control

[selinc.com/solutions/distribution](http://selinc.com/solutions/distribution)

The complex demands of distributed generation, renewable resources, and an evolving customer base present challenges to distribution systems everywhere. From protection fundamentals to advanced automation, SEL offers the most reliable and efficient solutions for every section of a utility-, industrial-, or commercial-scale distribution system.

## Applications

- Feeder protection
- Transformer protection
- Busbar protection
- Recloser control and protection
- Digital secondary systems
- Arc-flash protection
- Downed conductor detection
- Microgrid control systems (POWERMAX®)
- Distributed generation
- Power quality
- Distribution automation
- Substation automation



## Video

SEL-651R—A Better Way to Connect DERs

[video.selinc.com/detail/video/6084720804001](http://video.selinc.com/detail/video/6084720804001)

Substation

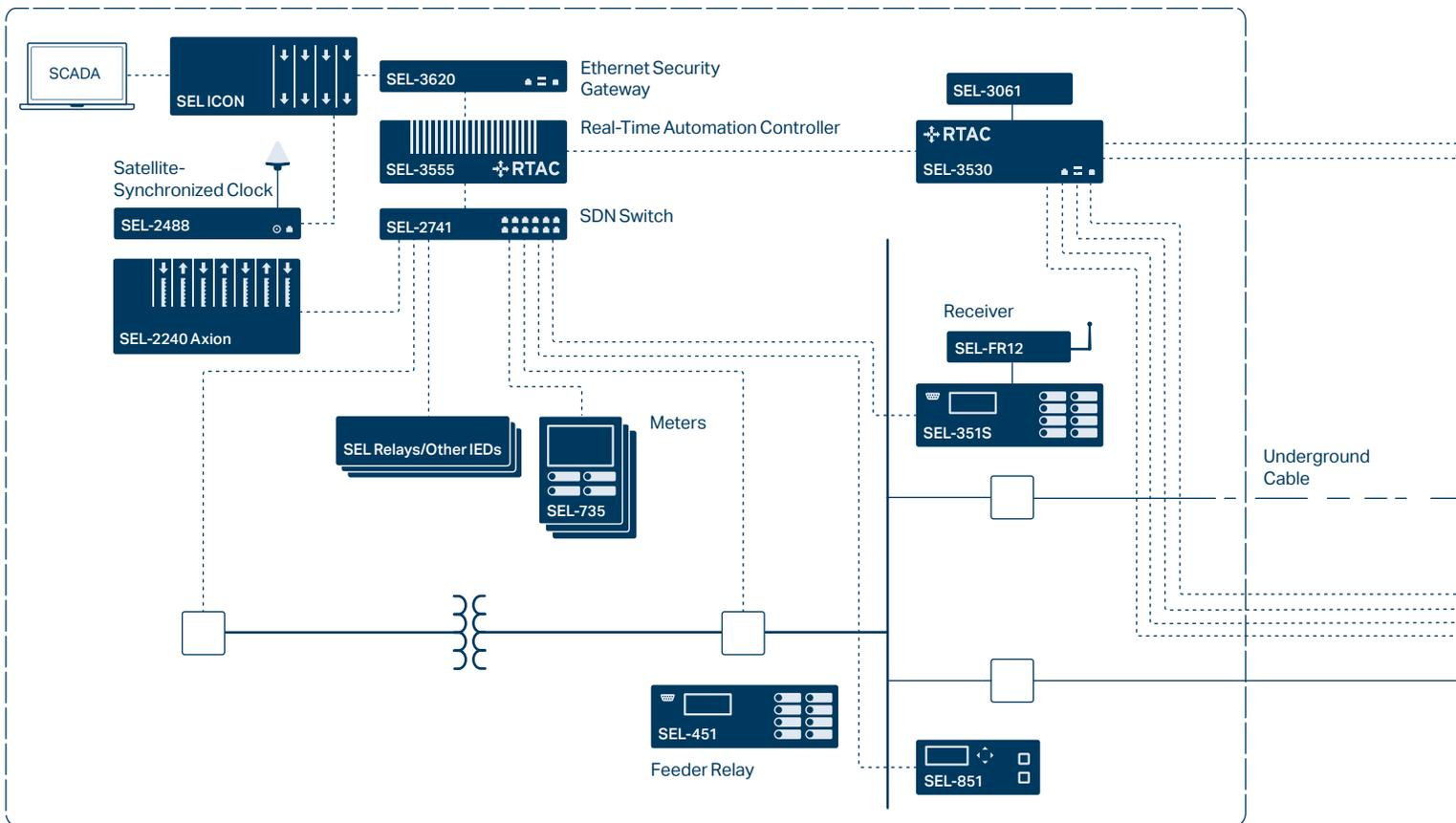

## Example System Diagram

Combine SEL distribution protection and control products with other SEL automation, monitoring, and wireless communications products for a comprehensive solution.

## Webinars

Finding Simplicity in the Complex World of Feeder Protection

[selinc.com/events/on-demand-webinar/134425](http://selinc.com/events/on-demand-webinar/134425)

Simple and Scalable—Fault Location, Isolation, and Service Restoration Solutions

[selinc.com/events/webinar/134693](http://selinc.com/events/webinar/134693)

Enhance Distribution Protection With the SEL Wireless Protection System

[selinc.com/events/on-demand-webinar/133828](http://selinc.com/events/on-demand-webinar/133828)

## Technical Papers

Solutions to Common Distribution Protection Challenges

[selinc.com/api/download/114346](http://selinc.com/api/download/114346)

Real-World Troubleshooting With Microprocessor-Based Recloser Controls

[selinc.com/api/download/125792](http://selinc.com/api/download/125792)

Case Study: High-Density Distribution Coordination Using High-Speed Communications

[selinc.com/api/download/130375](http://selinc.com/api/download/130375)

## White Papers

Fire Mitigation for Distribution

[selinc.com/api/download/126445](http://selinc.com/api/download/126445)

Wireless Current Sensing for Improved Distribution Capacitor Bank Control

[selinc.com/api/download/130665](http://selinc.com/api/download/130665)

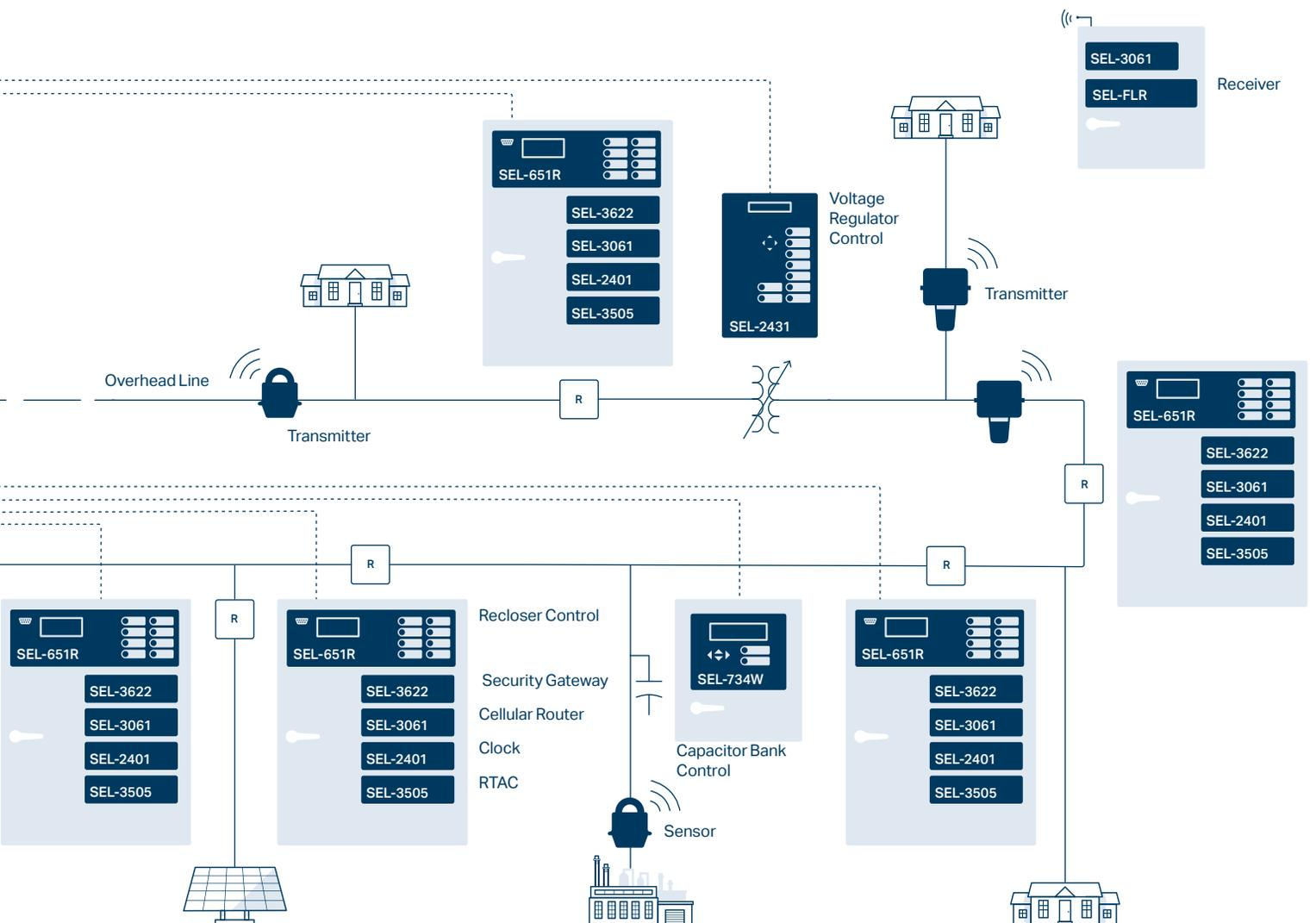



### SEL-851 Feeder Protection Relay

A compact relay for utility and industrial applications that provides overcurrent, voltage, and arc-flash protection as well as versatile communications.



### SEL-751 Feeder Protection Relay

Ideal for industrial and utility feeder protection, offering an intuitive color touchscreen, fast and secure arc-flash detection, flexible I/O, and advanced communications.



### SEL-451 Protection, Automation, and Bay Control System

Flexible overcurrent protection with complete substation bay control.



### SEL-351 Protection System

Transmission or distribution overcurrent protection, monitoring, and control.



### SEL-351A Protection System

An economical solution for distribution feeder protection.



### SEL-351S Protection System

Comprehensive feeder and overcurrent protection perfect for industrial and utility feeder applications.



### SEL-501 Dual Universal Overcurrent Relay

Two complete and independent groups of protection in one low-cost unit for feeders, buses, transformers, motors, and breakers.



### SEL-551/551C Overcurrent/Reclosing Relay

Distribution protection and control in new and retrofit installations.



### SEL Wireless Protection System

- SEL-FT50 Fault Transmitter
- SEL-RP50 Fault Repeater
- SEL-FR12 Fault Receiver

Enhance distribution protection by enabling relays to block reclosing for underground faults, by enabling fast bus tripping, or by coordinating high-density recloser trip blocking.

Applications	SEL-451	SEL-351	SEL-351A	SEL-351S	SEL-851	SEL-751	SEL-751A	SEL-501/501-2	SEL-551/551C
Distribution Feeder Protection	■	■	■	■	■	■	■	■	■
Breaker Failure (BF) Protection	■	■	f	■	■	■	■	+	f
Generator Inertia Protection	■	■	■	■		+	+		
Synchronism Check (25)	■	■	■	■		+	+		
Underfrequency Load Shedding	f	■	■	■	+	■	■		
Undervoltage Load Shedding	f	■	■	■	+	+	+		

### Protection

27/59 Under-/Overvoltage	■	■	■	+	+	+	+		
32 Directional Power Elements	■	+		+	+	+	+		
49 IEC Line/Cable Thermal Overload	■					■			
50 (P,N,G,Q) Overcurrent Element (Phase, Neutral, Ground, Negative Sequence)	■	■	■	■	■	■	■	■	■
51 (P,N,G,Q) Time Overcurrent Element (Phase, Neutral, Ground, Negative Sequence)	■	■	■	■	■	■	■	■	■
67 (P,N,Q) Directional Overcurrent (Phase, Neutral, Negative Sequence)	■	■	■	■		+			
78VS Vector Shift							+		
81 Over-/Underfrequency	■	■	■	■	+	■	+		
Separate Neutral Overcurrent	■	■	■	■	■	■	■		■
Load Encroachment Supervision	■	■	■	■		+			
Low-Energy Analog (LEA) Voltage Inputs	+						+		
Directional Sensitive Earth Fault Protection		+	+	+		+			
Pilot Protection Logic	■	■		■					
81R Rate-of-Change of Frequency (df/dt)	■	■	■	■		+	+		
81RF Fast Rate-of-Change of Frequency	f					+	+		
Harmonic Blocking	■	■	+	■	■	■			
Arc Sense™ Technology (AST) High-Impedance Fault Detection	+						+		
Arc-Flash Detection					+	+	+		
Phantom Phase Voltage		■	■	■					
Current/Voltage Channels	6/6	4/4	4/4	4/4	4/0 4/3*	4/3 4/5*	4/0 4/5*	6/0	4/0
Complete Two-Breaker Control	■							■	

Instrumentation and Control	SEL-451	SEL-351	SEL-351A	SEL-351S	SEL-851	SEL-751	SEL-751A	SEL-501/501-2	SEL-551/551C
79 Automatic Reclosing	■	■	■	■	■	+	+		■
Fault Locating	■	■	■	■		+			
SELogic® Control Equations With Remote Control Switches	■	■	■	■	■	■	■		■
SELogic Counters	■				■	■	■		
Voltage Check on Closing	■	■	■	■		+	+		
SELogic Nonvolatile Latch	■	■	■	■	■	■	■		+
Nonvolatile Local Control Switches	■	■	+	■	■	■	■		■
Substation Battery Monitor	■	■	■	■		+	+		
Breaker/Recloser Wear Monitor	■	■	■	■		■	■		
Trip Coil Monitor	f	f	f	f		f	f		f
Voltage Sag, Swell, and Interruption (VSSI)	■	+		+					
Load/Signal Profile Recorder	■	+		+	■	■	■		
Sequential Events Recorder	■	■	■	■	■	■	■		■
Software-Invertible Polarities	■				■				
IEC 60255-Compliant Thermal Model	■								
DNP3 Level 2 Outstation	■	■	■	■	+	+	+		
Parallel Redundancy Protocol (PRP)	+	■	■	■		+			
IEEE 1588 Precision Time Protocol Version 2 (PTPv2)	+					+			
Time-Domain Link (TiDL®) Technology	+								
IEEE C37.118 Synchrophasors	■	■	■	■		■	■		
Bay Control	■					+			
Ethernet	+	■	■	■	■	+	+		
EtherNet/IP						+			
Built-In Web Server	■				■	■			
IEC 61850	+	+	+	+	+	+	+		
IEC 61850 Edition 2	+				+	+			
IEC 61850-9-2 Sampled Values Technology	+								
Firmware Option With MIRRORING BITS® Communications Available	■	■		■	■	■	■		
Simple Network Time Protocol (SNTP)	■	■	■	■	■	+	+		
Harmonic Metering		■	■	■	■				
RMS Metering	■	■	■	■	■	■	■		

■ Standard feature + Model option f May be created using settings



### **SEL-651R Advanced Recloser Control**

The SEL-651R provides Automatic Network Reconfiguration and three- and single-phase tripping. It can be used at distributed energy resource (DER) interconnections, for detecting down conductors, and in other distribution automation applications. It is compatible with popular reclosers.



### **SEL-651RA Recloser Control**

The SEL-651RA is a powerful, cost-effective, and flexible recloser control for 14-pin reclosers used in three-phase tripping applications. It can be used at DER interconnections, for detecting down conductors, and in other distribution automation applications. It is compatible with popular reclosers.



### **SEL-351RS Kestrel® Single-Phase Recloser Control**

The SEL-351RS provides integrated logic and communications and comprehensive protection for single-phase applications.



### **SEL-734B Advanced Monitoring and Control System**

The SEL-734B includes low-energy analog inputs and provides advanced monitoring and control capabilities for applications such as capacitor bank control and feeder monitoring.



### **SEL-734W and LINAM™ WCS Capacitor Bank Control and Wireless Current Sensor**

This solution is a quick and simple way to provide accurate current-based control for capacitor bank installations and improve power quality.



### **SEL-2431 Voltage Regulator Control**

The SEL-2431 optimizes system voltages by using directional voltage profiles and detailed tap change event reports.

	SEL-351RS Kestrel®	SEL-651R	SEL-651RA
<b>Applications</b>			
Distribution Feeder Protection	■	■	■
Breaker Failure Protection	<i>f</i>	<i>f</i>	<i>f</i>
Generator Intertie Protection		■	■
Recloser Control	■	■	■
Synchronism Check		■	+
Underfrequency Load Shedding	■	■	■
Undervoltage Load Shedding	■	■	■
<b>Protection</b>			
25 (G,T) Generator/Intertie Synchronism Check		■	■
27/59 Under-/Overvoltage	■	■	■
32 Directional Power Elements	■	■	+
50 (P,N,G,Q) Overcurrent Element (Phase, Neutral, Ground, Negative Sequence)	■	■	■
51 (P,N,G,Q) Time Overcurrent Element (Phase, Neutral, Ground, Negative Sequence)	■	■	■
67 (P,N,Q) Directional Overcurrent (Phase, Neutral, Negative Sequence)		■	■
78VS Vector Shift		■	■
81 Over-/Underfrequency	■	■	■
81R Rate-of-Change of Frequency (df/dt)	■	■	■
81RF Fast Rate-of-Change of Frequency (ROCOF)		■	■
Separate Neutral Overcurrent		■	■
Load-Encroachment Supervision		■	■
Low-Energy Analog (LEA) Voltage Inputs		+	+
Directional Sensitive Earth Fault Protection		■	■
Pilot Protection Logic		<i>f</i>	<i>f</i>
Harmonic Blocking	■	■	■
Fast Islanding Detection		■	■
Arc Sense Technology (AST) High-Impedance Fault Detection		+	+
Phantom Phase Voltage	■	■	■
Current/Voltage Channels	1/1	4/6	4/1 4/6

	SEL-351RS Kestrel®	SEL-651R	SEL-651RA
<b>Instrumentation and Control</b>			
79 Automatic Reclosing	■	■	■
Fault Locating	■	■	+
SELogic Control Equations With Remote Control Switches	■	■	■
SELogic Counters	■	■	■
Voltage Check on Closing	■	■	■
SELogic Nonvolatile Latch	■	■	■
Nonvolatile Local Control Switches	■	■	■
Display Points	■	■	■
Breaker/Recloser Wear Monitor	■	■	■
Trip Coil Monitor	<i>f</i>	<i>f</i>	<i>f</i>
Voltage Sag, Swell, and Interruption (VSSI)	■	■	■
Load/Signal Profile Recorder	■	■	■
Sequential Events Recorder	■	■	■
DNP3 Level 2 Outstation	■	■	■
IEEE C37.118 Synchrophasors	■	■	■
IEEE 1547-2018		■	■
Ethernet	■	■	■
IEC 61850	+	+	+
Simple Time Network Protocol (SNTP)	■	■	■
Harmonic Metering	■	■	■
RMS Metering	■	■	■

■ Standard feature    + Model option    *f* May be created using settings



# Fault Indicators, Sensors, and CTs

[selinc.com/products/distribution/fault-indicators](http://selinc.com/products/distribution/fault-indicators) | [selinc.com/products/FIS/accessories](http://selinc.com/products/FIS/accessories)

SEL fault indicators and sensors improve reliability by indicating the fault path to speed up the fault location time and reduce outage duration. Suitable for overhead and underground installations, SEL fault indicators and sensors work in a wide range of applications—from overcurrent fault detection to enhancing system protection.

## Example System Diagram

Combine SEL fault indicators and sensors with SEL protective relays to enhance protection solutions.

## Applications

- Unfused taps
- Long feeders with midline reclosers or sectionalizers
- Overhead-to-underground transitions
- Feeders that experience recurring faults
- Subsurface or pad-mounted transformers
- Switchgear
- Sectionalizing cabinets
- Junction boxes
- Splices



## Video

How to Install the AR360 AutoRANGER® Fault Indicator

[video.selinc.com/detail/videos/fault-indicators/video/2925549374001](http://video.selinc.com/detail/videos/fault-indicators/video/2925549374001)

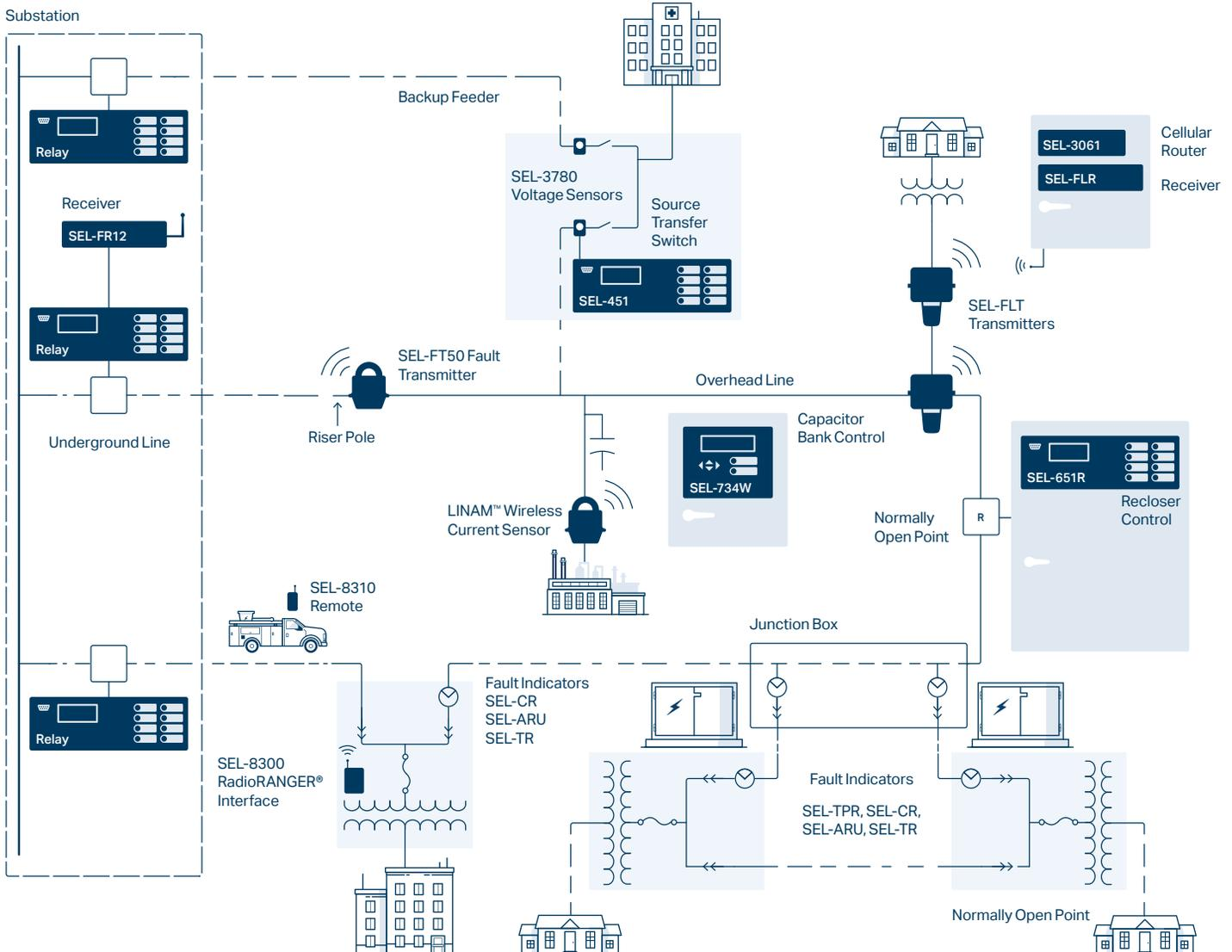

## Webinars

Improve System Visibility and Reliability With SEL's Wireless Fault Indication System

[selinc.com/events/webinar/134158](http://selinc.com/events/webinar/134158)

Enhance Distribution Protection With the SEL Wireless Protection System

[selinc.com/events/webinar/133828](http://selinc.com/events/webinar/133828)

## Technical Papers

Emerging Communications and Sensor Technologies That Advance Distribution Automation

[selinc.com/api/download/124511](http://selinc.com/api/download/124511)

Fast Wind Farm Restoration Using Wireless Fault Sensors to Identify Faulted Segments

[selinc.com/api/download/130379](http://selinc.com/api/download/130379)

Locating Faults in Urban Underground Vaults at CFE

[selinc.com/api/download/4481](http://selinc.com/api/download/4481)

## White Paper

Fire Mitigation for Distribution

[selinc.com/api/download/126445](http://selinc.com/api/download/126445)



### SEL-FLT and SEL-FLR Fault and Load Transmitter and Receiver System

Improve overall distribution system reliability with the SEL-FLT and SEL-FLR system, which accurately indicates faults and monitors load. Speed up deployment in pole-mount applications with the system's new enclosure.



### SEL-AR360 and SEL-AR Overhead AutoRANGER Fault Indicators

Locate momentary and permanent faults in overhead applications. The SEL-AR360 and SEL-AR automatically adjust their trip thresholds to coordinate with the load current in distribution systems.



### SEL-ER Overhead Electrostatic Reset Fault Indicator

Provide maintenance-free fault indication with a battery-free design and automatic voltage reset.



### SEL Wireless Protection System

Enhance distribution protection by enabling relays to block reclosing for underground faults, by enabling fast bus tripping, or by coordinating high-density recloser trip blocking.



### SEL-734W and LINAM™ WCS Capacitor Bank Control and Wireless Current Sensor

This solution is a quick and simple way to provide accurate current-based control for capacitor bank installations and improve power quality.



### RadioRANGER® Underground Wireless Fault Indication System

Reduce the need to access vaults or open pad-mounted enclosures to retrieve the fault indicator status. Decrease fault-locating time and improve safety.



### SEL-ARU Underground AutoRANGER Fault Indicator

Use the Dynamic Delayed Trip feature to improve coordination with upstream protection, maximizing reliable performance.



### SEL-TPR Underground Test Point Reset Fault Indicator

Easily install the SEL-TPR on most brands of 200 A or 600 A elbows with capacitive test points. It is ideal for pad-mounted transformer and switchgear applications.



### SEL-CR Underground Current Reset Fault Indicator

Monitor underground systems with the SEL-CR, which is powered by the load current present on an energized line.



### SEL-SR Underground Secondary/Low-Voltage Reset Fault Indicator

Apply the SEL-SR to pad-mounted transformers when there is insufficient primary current to power and reset current-powered fault indicators.



### SEL-TR Underground Timed-Reset Fault Indicator

Indicate both momentary and permanent faults in underground distribution systems with low load and low voltage.



### SEL-3780 Test Point Voltage Sensor

Detect system voltage loss on distribution elbows with capacitive test points. The SEL-3780 is part of an economical solution for source transfer schemes.



### SEL-PILC Underground Paper-Insulated Lead-Covered Cable Fault Indicator

Apply the SEL-PILC on paper-insulated lead-covered cables. It features a rugged design and can be submerged in up to 15 feet of water.



### **SEL-MR Manual Reset Fault Indicator**

Troubleshoot overhead and underground applications up to 38 kV with this portable, fault-powered manual reset fault indicator.



### **SEL-VIN Voltage Indicator**

Apply the line-powered SEL-VIN to indicate the presence of voltage at or above 2 kV (phase to ground) using a flashing neon lamp. Easily install SEL-VINs on the test point of a 200 A elbow, 600 A T-body, or 600 A basic insulating plug.



### **SEL-CT Split-Core Current Transformers**

Economically add SEL CTs to existing wiring and electrical equipment without interrupting service.



### **SEL-SCT Submersible Separable-Core Current Transformer**

Easily add the SEL-SCT in subsurface vaults where flooding can occur. The separable-core design allows the SEL-SCT to be opened and installed without interrupting the connection.



# Metering

[selinc.com/solutions/metering-solutions](http://selinc.com/solutions/metering-solutions) | [selinc.com/engineering-services/energy-metering](http://selinc.com/engineering-services/energy-metering)

SEL metering products help operators identify power quality issues and improve energy usage in generation, interchange, transmission, distribution, industrial, and commercial applications.

## Applications

- Power quality monitoring and troubleshooting
- Usage reporting and billing management system integration
- Load profiling and monitoring

## White Paper

Achieve Accurate Metering in Modern Nonsinusoidal Power System Conditions

[selinc.com/api/download/123140](http://selinc.com/api/download/123140)

## Webinar

Solutions for Optimizing Energy Metering and Demand Management

[selinc.com/events/on-demand-webinar/134511](http://selinc.com/events/on-demand-webinar/134511)



## Customer Story

SEL Meter Helps Data Center Supply High-Quality, Uninterrupted Power

[selinc.com/solutions/success-stories/Vantage-Data](http://selinc.com/solutions/success-stories/Vantage-Data)

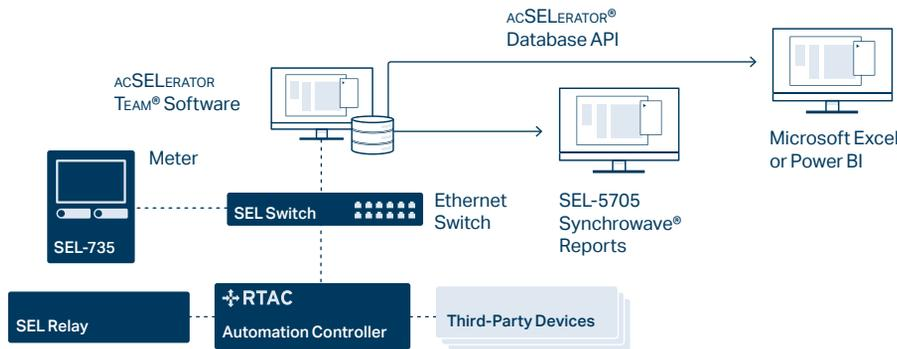

## Example System Diagram

Combine the SEL-735 with other SEL devices and software for a comprehensive metering data management solution.



## SEL-735 Power Quality and Revenue Meter

SEL meters offer bidirectional, full four-quadrant, and high-accuracy energy metering as well as precise and reliable power quality measurements. Multiple mounting and enclosure options and accessories are available; visit [selinc.com/products/73x/meter-options](http://selinc.com/products/73x/meter-options).

## SEL-5705 Synchronwave® Reports Software

The SEL-735 metering data collected and stored by ACSELERATOR TEAM® SEL-5045 Software allows you to quickly analyze data, identify usage trends, and diagnose system problems.

## SEL-5705 Synchronwave Reports Meter Data and Power Quality Software Bundle

The bundle combines TEAM and Synchronwave Reports software, allowing you to automate data retrieval and trend data quickly through a list of available reports.

## SEL-5230 ACSELERATOR Database API

The API provides third-party software tools with access to data that can be used by enterprise-level systems, such as an energy management system or a billing system, to integrate data reporting.

## SEL-735 Power Quality Options

General	Basic	Intermediate	Advanced
Display	Customizable three-line or single-line display	Customizable three-line or single-line display	One and three-line monochromatic display, or optional customizable 5-inch color touchscreen display
Front Port	ANSI Type II optical port or EIA-232 port	ANSI Type II optical port or EIA-232 port	ANSI Type II optical port or EIA-232 port; Type-C USB*
Memory	128 MB	256 MB	1 GB
Maximum Harmonic Order	15th	63rd	63rd
Interharmonic Quantities	No	No	Yes
Harmonic Angles	No	No	Yes
Power Harmonics	No	No	Yes

### Waveform Capture Event Reports

Samples Per Cycle	16	16, 128	16, 128, 512
Duration (Cycles)	15	15–600	15–600
Number of Events	256	33–6,200	101–10,000
COMTRADE Reports	Yes	Yes	Yes
Wave View Oscillography	No	No	Yes

### Load Profile Recorder

Recorders × Channels	1 × 16	12 × 16	32 × 16
Acquisition Rates	1–120 min	3–59 s, 1–120 min	3–59 s, 1–120 min

### Storage Duration for 10-Minute Interval Data

16 Channels	10 years	20 years	20 years
192 Channels	N/A	1.5 years	9.5 years
512 Channels	N/A	N/A	3.5 years

### Voltage Sag, Swell, and Interruption (VSSI) Recorder

Typical Number of Summary Events	260	260	600
Number of Detailed Rows	60,000	60,000	130,000
Minimum Disturbance Duration	1/4 cycle	1/4 cycle	1/4 cycle
Sampling Rate	4 samples/cycle–1 sample/day, adaptive	4 samples/cycle–1 sample/day, adaptive	4 samples/cycle–1 sample/day, adaptive

### Sequential Events Recorder (SER)

Number of Events	>80,000	>80,000	>80,000
Number of Channels Monitored	≤72	≤72	≤72

### IEC 61000-4-30 Power Quality Compliance

150/180-Cycle, 10-Minute, 2-Hour Aggregation	N/A	Class A	Class A
Flicker	N/A	Class A (10 min, 2 hr updates)	Class A (1 min, 10 min, 2 hr updates)
Voltage Harmonics	Class A	Class A	Class A
Harmonic Currents	Class A	Class A	Class A

\*Optional feature



# Automation

[selinc.com/products/automation/operations](http://selinc.com/products/automation/operations) | [selinc.com/engineering-services/automation](http://selinc.com/engineering-services/automation)

Increase system reliability and operation efficiency using SEL automation and computing platforms, which offer scalable and modular solutions for data concentration, protocol conversion, and more. SEL automation solutions allow you to implement a broad set of functionalities or choose a subset and add more capabilities over time.

## Applications

- Remote terminal unit replacement
- Automated data collection
- Digital fault recording systems
- Network device auditing
- Power management and control systems (POWERMAX®)
- Distributed energy resource integration
- Automatic fault location, isolation, and service restoration
- Bay control



## Customer Stories

System-Wide Automation Solution Prolongs Life of Existing Relays

[selinc.com/solutions/success-stories/system-wide-automation](http://selinc.com/solutions/success-stories/system-wide-automation)

A System of Robust Reliability for the Water and Wastewater Industry

[selinc.com/solutions/success-stories/brunswick](http://selinc.com/solutions/success-stories/brunswick)

## Example System Diagram

Combine SEL automation and computing platforms with SEL protective relays and software for a comprehensive solution.

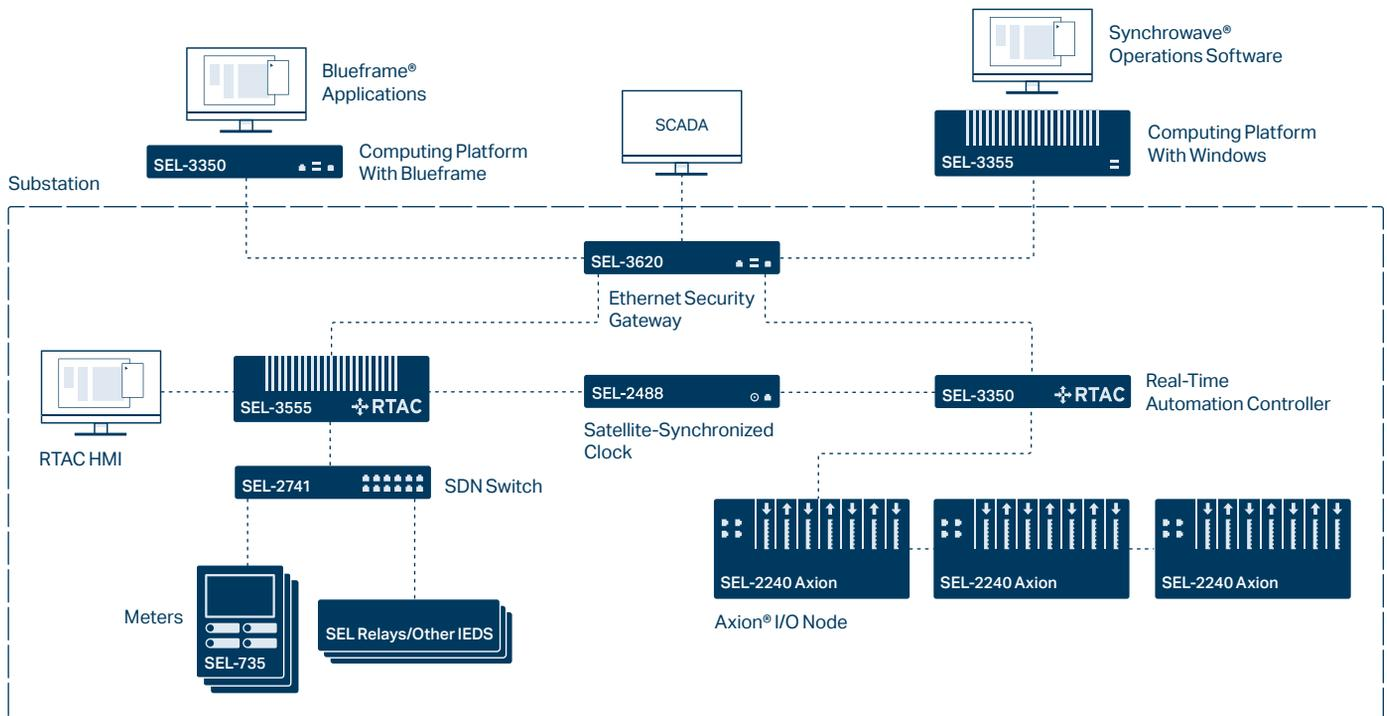

## Webinars

RTAC and Axion® Advancements for RTU and Substation Gateway Applications  
[selinc.com/events/on-demand-webinar/137925](http://selinc.com/events/on-demand-webinar/137925)

Managing DERs With RTAC Grid Connect

[selinc.com/events/on-demand-webinar/138107](http://selinc.com/events/on-demand-webinar/138107)

Software-Based Password Rotation With DMA Credential Management  
[selinc.com/events/on-demand-webinar/137643](http://selinc.com/events/on-demand-webinar/137643)

## Technical Papers

Simplifying Compliance: An Integrated Approach to Meeting NERC PRC-002 and PRC-005 Requirements  
[selinc.com/api/download/130034](http://selinc.com/api/download/130034)

New Advancements in Solar Grid Controllers  
[selinc.com/api/download/130047](http://selinc.com/api/download/130047)

Wind Farm Volt/VAR Control Using a Real-Time Automation Controller  
[selinc.com/api/download/99167](http://selinc.com/api/download/99167)

## White Paper

Using Defense in Depth to Safely Present SCADA Data for Read-Only and Corporate Reporting  
[selinc.com/api/download/120437](http://selinc.com/api/download/120437)

## Related Materials

SEL Digital Fault Recording (DFR) Systems  
[selinc.com/api/download/122510](http://selinc.com/api/download/122510)

POWERMAX Solutions  
[selinc.com/api/download/106293](http://selinc.com/api/download/106293)



### SEL-3350 Computing Platform **NEW**

The SEL-3350 is a cost-effective model ideal for applications that require midlevel I/O and computation. It can be deployed as an RTAC, an industrial computer running a Microsoft Windows or Linux OS, or a Blueframe application platform.

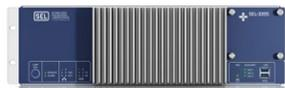

### SEL-3355 Computing Platform

The SEL-3355 is a server-class computing platform built to withstand harsh environments in utility substations and industrial control and automation systems. It can be deployed as an industrial computer running a Microsoft Windows or Linux OS or as a Blueframe application platform.



### SEL-3360S/3360E Compact Computing Platform

These models match the performance, ruggedness, and configuration flexibility of the SEL-3355 and are ideal for surface- or panel-mount applications. They can be deployed as industrial computers running a Microsoft Windows or Linux OS or as Blueframe application platforms.



### SEL-3530/3530-4 Real-Time Automation Controller

These RTACs deliver complete and flexible system control with integrated security, seamless configuration, unified logic, and high reliability.

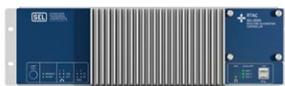

### SEL-3555 Real-Time Automation Controller

The SEL-3555 provides powerful processing for large-scale automation projects.



### SEL-3560E/3560S Real-Time Automation Controller

These RTACs offer powerful processing for large-scale automation projects in a compact form factor.



### SEL-2240 Axion®

The Axion is a fully integrated, modular I/O and control solution for utility and industrial applications. With its new 7-inch color touchscreen display option, the Axion can be applied as a bay controller, providing comprehensive monitoring and reliable control of substation bays.



### SEL-3505/3505-3 Real-Time Automation Controller

These RTACs offer powerful automation, reporting, and control for low-voltage, limited-space applications.



### SEL-3390 PCIe Adapter Cards

- SEL-3390E4 Network Adapter Card
- SEL-3390S8 Serial Adapter Card
- SEL-3390T Time and Ethernet Adapter Card

These expansion cards let you add ports and connectivity to SEL and other industrial automation and computing platforms and may also be used in non-SEL computers.



### SEL-2411 Programmable Automation Controller

The SEL-2411 provides flexible I/O for automatic control, SCADA, station integration, remote monitoring, and plant control systems.



### SEL-2411P Pump Automation Controller

The SEL-2411P is a standalone, preconfigured, SCADA-ready system for control and monitoring of water and wastewater pump applications.



### SEL-2440 DPAC Discrete Programmable Automation Controller

The SEL-2440 offers utility-grade I/O, powerful processing, flexible communications, and microsecond timing.

### SEL RTAC HMI

The SEL RTAC HMI offers an easy way to visualize data to monitor and control your system.

## SEL Blueframe

### SEL Blueframe Application Platform

Scalable and flexible, SEL Blueframe provides a secure operational technology (OT) platform for installing applications and for managing and exchanging data between supported applications.

### Distribution Management System (DMS) Application Suite

The DMS suite includes a FLISR (fault location, isolation, and service restoration) application package, which reduces customer outages, improves reliability metrics, and provides rapid fault detection and system restoration.

### Data Management and Automation (DMA) Application Suite

DMA applications automatically collect, store, and manage device-specific information to simplify day-to-day management of a system of devices and to support compliance. Applications include:

- Disturbance Monitoring—Collect oscillography and Sequence of Events (SOE) data.
- Configuration Monitoring—Collect configuration and property data.
- Credential Management—Initiate device credential rotation and central storage.
- Custom Monitoring—Collect specific device files or command results.
- Meter Monitoring—Collect LDP and VSSI reports from SEL devices. **NEW**

Applications	SEL-3355	SEL-3360E	SEL-3360S	SEL-3350	SEL-3555	SEL-3560E	SEL-3560S	SEL-3530	SEL-3530-4	SEL-2240	SEL-3505/3505-3	SEL-3532/3533	SEL-2411	SEL-2411P	SEL-2440
Collect, Scale Meter Data	#	#	#	+	■	■	■	■	■	■	■	■	■	■	
Condition Monitoring				■	■	■	■	■	■	■	■	■			
IED Report/Event Collection	+	+	+	■	■	■	■	■	■	■	■	■			
Distributed Fault Recording				+	■	■	■			■					
Collect Targets, Contact Input Status, Fault Location	#	#	#	+	■	■	■	■	■	■	■	■			
Enable Fiber-Optic Links	+	+		+	+	+		■	■	■	■	■	■	■	■
Control Through IED Outputs				■	■	■	■	■	■	■	■	■	■	■	■
IRIG-B Client Time Synchronization	■	■	■	■	■	■	■	■	■	■	■	+	■	■	■
IRIG-B Server Time Distribution	+	+		■	■	■	■	■	■	■	■	+			
Transparent "Port Switch"	#	#	#	+	■	■	■	■	■	■	■	■	■	■	■
Windows/Linux Applications in Harsh Environments	■	■	■	■											
Running Multiple Applications Simultaneously	■	■	■	■											
Installing Third-Party Software	■	■	■	■											
Security Appliance to Help Satisfy NERC CIP Requirements	#	#	#	+/#	■	■	■	■	■	■	■	■			
Network Monitoring and Intrusion Detection	#	#	#	#											
Virtualization Server	+/#	+/#	+/#												
Engineering Access Point	+/#	+/#	+/#	+/#	■	■	■	■	■	■	■	■			
IRIG-B Time Distribution and Network Time Protocol (NTP) Conversion	+	+		■	■	■	■	■	■	■	■	■/+			
Video Surveillance Control and Archiving/Physical Security Monitoring and Notification	#	#	#	#											
SEL Secure Kiosk	+	+	+	+											

**HMI**

Web-Based HMI	#	#	#	#	+	+	+	+	+	+		+			
Web-Based HMI Display Port					+	+	+								
Touchscreen Display	+/#	+/#	+/#	+/#						+			+		
LCD Display													■	■	

**Concentrate IED Data For:**

Distributed Control System (DCS)				+	■	■	■	■	■	■	■	■			
SCADA Master or Remote Terminal Unit (RTU)				+	■	■	■	■	■	■	■	■			
Remote Third-Party HMI				+	■	■	■	■	■	■	■	■			

**Features**

Protocol Redundancy (DNP3 and IEC 60870-5-101/104 Server)					■	■	■	■	■	■	■	■			
Primary and Standby LAN Support					■	■	■	■	■	■	■	■	■	■	■
Optoisolated Inputs/Programmable Outputs					■ <sup>1</sup>	■ <sup>1</sup>	■ <sup>1</sup>	+	■	+	+	■ <sup>1</sup>	+	+	+
IEC 61131 Logic Engine					■	■	■	■	■	■	■	■			
Cybersecurity Management					■	■	■	■	■	■	■	■			
Real-Time Operating System					■	■	■	■	■	■	■	■	■	■	■

■ Standard feature + Model option #Third-party software required <sup>1</sup>Alarm contact only

Hardware	SEL-3355	SEL-3360E	SEL-3360S	SEL-3350	SEL-3555	SEL-3560E	SEL-3560S	SEL-3530	SEL-3530-4	SEL-2240	SEL-3505/3505-3	SEL-3532/3533	SEL-2411	SEL-2411P	SEL-2440
Intel Xeon Quad-Core 64-Bit CPU	■	■	■		■	■	■								
Intel Atom Quad-Core 64-Bit CPU				■											
Power PC Single-Core CPU								■	■	■	■				
Maximum Error-Correcting Code (ECC) RAM (GB)	64	64	64	8	64	64	64	1	1	1	0.5				
Supports 3 Independent Displays With Digital Audio	■	■	■	■	■	■	■								
Analog Audio Ports: Line In, Line Out, Microphone	■	■	■												
4 Rear and 2 Front USB 3.1 Ports	■	■	■		■	■	■								
4 Rear USB 2.0 Ports and 2 Front USB 3.1 Ports				■											
Front RJ45 Ethernet Ports				1				1							
Rear Ethernet Ports	2	2	2	4	2	2	2	2	2	2	2				
Fiber-Optic Rear Ethernet Ports				+				+	+	+	+				
Additional Ethernet Ports, Copper RJ45, or Fiber-Optic SFP	8	4			8	4									
EIA-232 Serial Ports	2	2	2		2	2	2								
EIA-232/422/485 Serial Ports				16	6	6		17	4	4	4/3				
Additional EIA-232/422/485 Serial Ports	24	12		32	18	6		16							
IRIG-B Input (on COM1)	■	■	■		■	■	■								
IRIG-B Input and Output (BNC and Serial)	+	+		■	+	+		■	■	■	■				
19" Rack Mount	■			■	■			■	■	■			+	+	+
Panel Mount	+			+	+			+	+	+			+	+	+
Wall Mount		■	■			■	■								
Conduction Cooled Wall Mount		+	+			+	+								
PCI/PCIe Expansion Slots	5	2			3	1									
Solid-State Drives (2.5" SATA, 32 GB–2 TB Drive Options)	4	2	2	2	4	2	2								
High-Voltage 125–250 Vdc, 120–240 Vac Power Supply	■	■	+	■	■	■	+	■	■	■			■	■	■
Medium-Voltage 48–125 Vdc, 120 Vac Power Supply				■				■	■				■	■	■
Low-Voltage 48 Vdc Power Supply	■	■	+		■	■	+								
Low-Voltage 24–48 Vdc Power Supply				■								+			
12–24 Vdc Power Supply											■				
12 Vdc Power Supply			■				■								
External Power Supply			+				+								
Secondary Power Supply	+		+		+		+								
Hot-Swappable Power Supplies	■		■	+	■		■								
Alarm Contact, Alarm LED, Watchdog	■	■	■	■	■	■	■	■	■	■	■	■	■	■	■
Configurable Universal Control Input				■											
Programmable Auxiliary Bicolor LEDs	3	3	3	4	3	3	3								
Intel Active Management Technology (AMT) v11.8	■	■	■												
Infineon Trusted Platform Module (TPM) v2.0 (Hardware)	■	■	■	■	■	■	■								

■ Standard feature    + Model option

### Supported Operating Systems and Software

	SEL-3355	SEL-3360E	SEL-3360S	SEL-3350	SEL-3555	SEL-3560E	SEL-3560S	SEL-3530	SEL-3530-4	SEL-2240	SEL-3505/3505-3	SEL-3532/3533	SEL-2411	SEL-2411P	SEL-2440
SEL Real-Time Automation Controller (RTAC)				+	■	■	■	■	■	+	■	■			
SEL Blueframe Operating System	+	+	+	+											
SEL Software	+	+	+	+											
Microsoft Windows 10 IoT Enterprise LTSC	+	+	+	+											
Microsoft Windows Server Standard	+	+	+	+											
CentOS Linux, Red Hat Enterprise Linux, Ubuntu Linux, or VMware ESXI	‡	‡	‡	‡											
McAfee Whitelist Antivirus	+	+	+	+											

### Network

Telnet				+	■	■	■	■	■	■	■	■	■	■	■
Secure Shell (SSH)				+	■	■	■	■	■	■	■	■			
SMTP/Email Notification				+	■	■	■	■	■	■	■	■			
FTP Server													■	■	■
DNP3 LAN/WAN Client/Server				+	■	■	■	■	■	■	■	■	+	■	+
Modbus TCP				+	■	■	■	■	■	■	■	■	■	■	■
IEC 61850 MMS Client/Server				+	+	+	+	+	+	+	+	+	+		+
IEC 61850 GOOSE				+	+	+	+	+	+	+	+	+	+		+
IEC 60870-5-104 Client/Server				+	■	■	■	■	■	■	■	■			
IEEE C37.118 Client/Server				+	■	■	■	■	■	■	■	■			
Flex Parse				+	■	■	■	■	■	■	■	■			
FTP/SFTP Client/Server				+	■	■	■	■	■	■	■	■			
SNMP Client/Server				+	■	■	■	■	■	■	■	■			
Lightweight Directory Access Protocol (LDAP)				+	■	■	■	■	■	■	■	■			
EtherCAT®				+	■	■	■	■	■	■	■	■			
EtherNet/IP				+	■	■	■	■	■	■	■	■			
Precision Time Protocol (PTP)/ Network Time Protocol (NTP)				+	■	■	■	■	■	■	■	■			■
Simple Network Time Protocol (SNTP)				+	■	■	■	■	■	■	■	■	■	■	■
Parallel Redundancy Protocol (PRP)				+	■	■	■	■	■	■	■	■	■	■	■
Parallel Redundancy Protocol (PRP) for Windows	+	+	+	+											
OPC UA Client/Server				+	+	+	+								
MQTT Client				+	■	■	■	■	■	■	■	■			

### Serial Port Protocols

SEL MIRRORING BITS® Communications	+	+		■	■	■	■	■	■	■	■	■	■	■	■
DNP3 Server				+	■	■	■	■	■	■	■	■	+	■	+
Modbus RTU Binary Client/Server				+	■	■	■	■	■	■	■	■	■	■	■
IEC 60870-5-101 Client/Server				+	■	■	■	■	■	■	■	■			
LG 8979 Client/Server				+	■	■	■	■	■	■	■	■			
SES-92 Server				+	■	■	■	■	■	■	■	■			
DNP3 Client/Server				+	■	■	■	■	■	■	■	■			
CP 2179 Client				+	■	■	■	■	■	■	■	■			
SEL Fast Messages, Interleaved With ASCII Client/Server				+	■	■	■	■	■	■	■	■			
SEL Synchrophasors Client				<i>f</i>	<i>f</i>	<i>f</i>	<i>f</i>	<i>f</i>	<i>f</i>	<i>f</i>	<i>f</i>	<i>f</i>			
IEC 60870-5 101 Client/Server				+	■	■	■	■	■	■	■	■			
CDC Type 2 Client/ Server				+	■	■	■	■	■	■	■	■			
ASCII Flex Parse				+	■	■	■	■	■	■	■	■			

■ Standard feature    + Model option    ‡ Supported for customer installation    *f* May be created using settings



# WAN and LAN Networks

[selinc.com/products/communications/wide-area-network](http://selinc.com/products/communications/wide-area-network) | [selinc.com/products/communications/local-area-networks](http://selinc.com/products/communications/local-area-networks)

SEL devices combine the connectivity, performance, cybersecurity, and ruggedness required for WAN and LAN applications.

## Applications

- Teleprotection systems
- Operational technology (OT) networking
- OT Software-defined networking (SDN)
- Analog leased-line service migration
- IT/OT convergence
- IEC 61850 digital secondary systems
- Special protection systems
- Microgrids
- Distributed renewables
- Remedial action schemes
- Facility-related control systems
- NERC CIP

## Webinars

Best Practices for Successful IT/OT Network Convergence

[selinc.com/events/webinar/128773](http://selinc.com/events/webinar/128773)

Redefining Ethernet Performance With Software-Defined Networking

[selinc.com/events/webinar/130273](http://selinc.com/events/webinar/130273)

## Technical Papers

Using Software-Defined Networking to Build Modern, Secure IEC 61850-Based Substation Automation Systems

[selinc.com/api/download/130126](http://selinc.com/api/download/130126)

Deterministic Communications for Protection Applications Over Packet-Based Wide-Area Networks

[selinc.com/api/download/121072](http://selinc.com/api/download/121072)

Implementing Security for Critical Infrastructure Wide-Area Networks

[selinc.com/api/download/21474836912](http://selinc.com/api/download/21474836912)

Taking Full Control of Your Process Bus LAN Using New Ethernet Packet Transport Technologies

[selinc.com/api/download/119756](http://selinc.com/api/download/119756)



## Customer Stories

Belgium Integrates Offshore Wind Power Into European Grid

[selinc.com/featured-stories/elia](http://selinc.com/featured-stories/elia)

A Modern WAN—Simple, Economical, Elegant

[selinc.com/solutions/success-stories/a-modern-wan](http://selinc.com/solutions/success-stories/a-modern-wan)

## White Paper

Software-Defined Networking Changes the Paradigm for Mission-Critical Operational Technology Networks

[selinc.com/api/download/118416](http://selinc.com/api/download/118416)

Simplifying NERC CIP Compliance With SEL SDN

[selinc.com/api/download/130206](http://selinc.com/api/download/130206)

## Video

OT Software-Defined Networking: Purpose Engineered for Critical Infrastructure

[video.selinc.com/detail/video/1726869976932833649](http://video.selinc.com/detail/video/1726869976932833649)

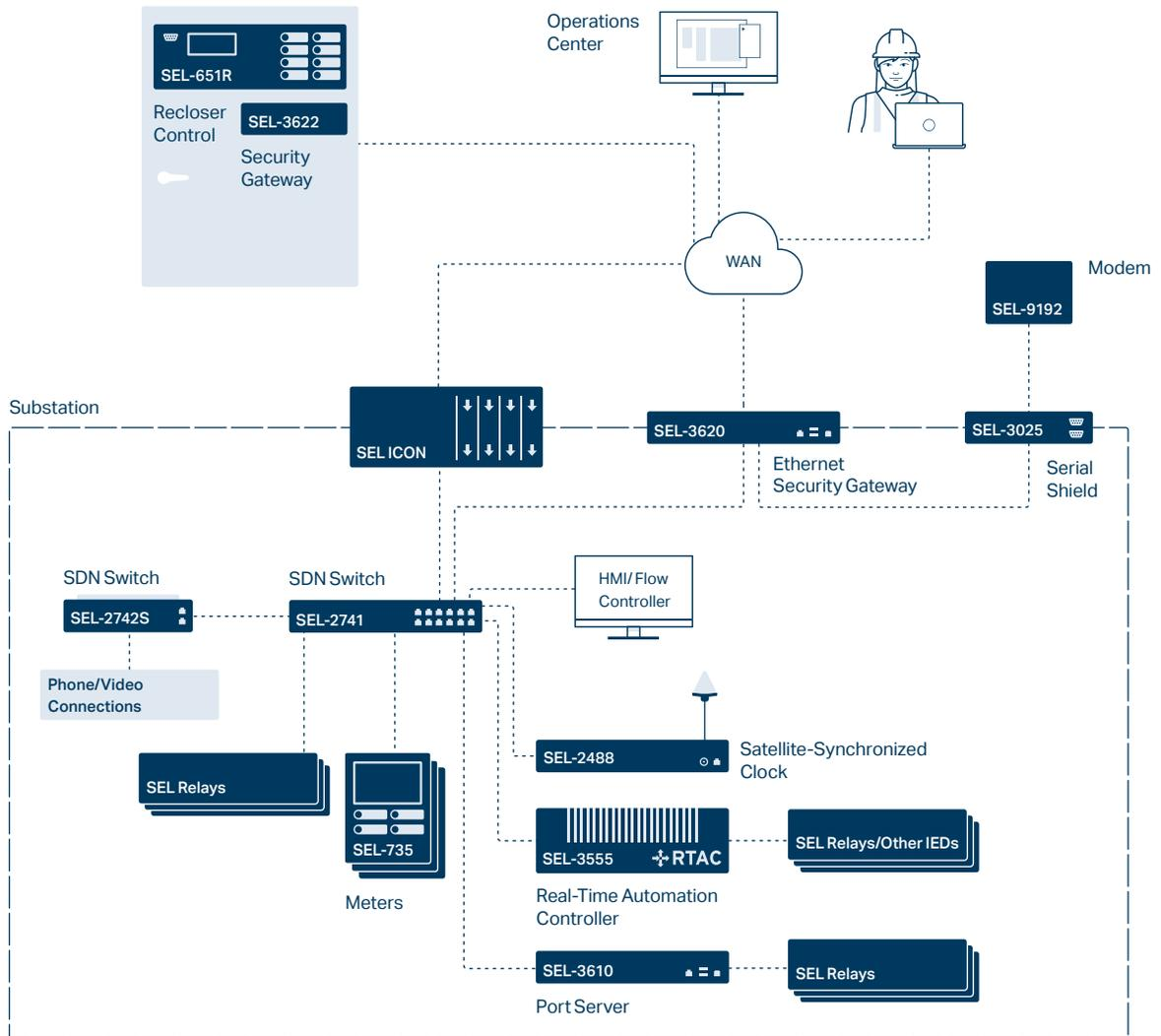

**Example System Diagram**

Combine SEL LAN and WAN devices with other SEL protection, automation, and control products for a comprehensive solution.



### SEL ICON® Integrated Communications Optical Network

The ICON is a WAN multiplexer optimized for industrial and utility applications. By combining time-division multiplexing (TDM) and Ethernet transport options with a comprehensive range of data interfaces, the ICON makes it easy to migrate legacy network technologies to a packet-based solution.



### SEL-2741 Ethernet Switch

The SEL-2741 Ethernet Switch is a 24-port SDN deny-by-default, zero trust, multilayer local-area network Ethernet switch designed to perform reliably in the toughest environmental conditions commonly found in critical infrastructure.



### SEL-2740S Software-Defined Network Switch

The SEL-2740S is the industry's first field-hardened SDN-enabled switch and improves cybersecurity and Ethernet performance in mission-critical applications.



### SEL-2742S Software-Defined Network Switch

The SEL-2742S is a 12-port, DIN-rail mount SDN switch for industrial environments. It combines with SEL-5056 Software-Defined Network Flow Controller software to simplify network engineering and improve LAN security.



### SEL-3620 Ethernet Security Gateway or SEL-3622 Security Gateway

The gateways each function as a router, VPN endpoint, and firewall device. They can provide secure and proxy user access for serial- and Ethernet-based IEDs.



### SEL-2730M Managed or SEL-2730U Unmanaged 24-Port Ethernet Switch

These switches let you build reliable, safe Ethernet networks in electrical substations, plants, and other mission-critical sites.



### SEL-3610 Port Server

The SEL-3610 increases the number of serial ports available to communications processors and computers and allows serial products to communicate securely through Ethernet networks.



### SEL-2725 Five-Port Ethernet Switch

The SEL-2725 allows you to easily connect devices to Ethernet networks.



### SEL-3025 Serial Shield®

The SEL-3025 protects serial communications with bump-in-the-wire security and strong, authenticated access controls.

Applications	SEL ICON	SEL-3620	SEL-3622	SEL-3610	SEL-2725	SEL-2730M	SEL-2741	SEL-2740S	SEL-2742S	SEL-2890
SONET WAN	■									
Ethernet LAN	■	■	■	■	■	■	■	■	■	■
Precise Time Distribution	■	■	■	■			■	■	■	
Engineering Access Control		■	■	■			■	■	■	
Connect Multiple Wired-Ethernet Devices to Network	■				■	■	■	■	■	
Convert Wired 10/100BASE-T Ethernet to Fiber-Optic 100BASE-FX Ethernet	■	■	■	■	■	■	■	■	■	
Convert Serial Links to Ethernet Links	■	■	■	■						■

## Features

Cryptography (Encryption and Authentication)	■	■	■	■						
User-Based Accounts	■	■	■	■		■	■	■	■	
Centralized Authentication Via Lightweight Directory Access Protocol (LDAP)	■ <sup>1</sup>	■	■	■		■	■	■	■	
Centralized Authentication Via Remote Authentication Dial-In User Service (RADIUS)		■	■	■		■				
Deny-by-Default Firewall		■	■				■	■	■	
Import/Export Configuration Files		■	■	■		■	■	■	■	
VPN		■	■							
Syslog Logging	■	■	■	■		■	■	■	■	
Network Management System (NMS) Software	■					■	■	■	■	
GPS Receiver	■									
Real-Time Latency Monitor	■									
Spanning Tree Protocol (STP)	*	■	■	■		■ <sup>2</sup>				
VLANs	■	■	■	■		■	■	■	■	
Ethernet Class of Service	■					■	■	■	■	

## Ethernet Ports, Connector

## Quantities

Copper 10BASE-T, RJ45										1
Copper 10/100BASE-T, RJ45	0–16 <sup>3</sup>	1–3	1–3	1–3	3–5	0–16 <sup>4</sup>		0–20	2–12	
Fiber-Optic 100BASE-FX, LC	4	0–2	0–2	0–2	0–2	0–16 <sup>4</sup>		0–20	0–6	
Copper 10/100/1000BASE-T, RJ45	4					4–8	0–24	0–4	0–4	
Fiber-Optic 1000BASE-X, LC	2 <sup>5</sup> /4 <sup>6</sup>					0–4 <sup>7</sup>		0–4	0–4	
Small Form-Factor Pluggable (SFP) Cages	2–6 <sup>8</sup>					4 <sup>7</sup>	0–24			
Total Ethernet Ports Supported	16	3	3	3	5	24	24	20	12	1

\*Feature coming early 2024.

<sup>1</sup>SEL-5052 Server NMS Software provides LDAP centralized authentication for the ICON.

<sup>2</sup>SEL-2730M supports STP plus IEEE 802.1D-2004 Rapid Spanning Tree Protocol (RSTP).

<sup>3</sup>SEL ICON can support up to 16 Ethernet ports using 8-port Ethernet Access Modules or Ethernet Bridging Access Modules.

<sup>4</sup>SEL-2730M base configuration supports 16 10/100BASE-T copper ports, with the option to substitute 100BASE-FX fiber-optic ports in various groupings.

<sup>5</sup>SEL-8021-1 Line Module supports 2 fiber-optic Gigabit interfaces.

<sup>6</sup>SEL-8036-1 Ethernet Bridging Access Module supports 4 fiber-optic 100BASE-FX/Gigabit interfaces.

<sup>7</sup>SEL-2730M base configuration includes 4 copper GigE ports and 4 SFP cages for optional gigabit fiber-optic or copper 10/100/1000BASE-T Ethernet ports. SEL SFP transceivers are required.

<sup>8</sup>SEL ICON uses SFP cages for SONET and GigE fiber-optic interfaces.



# Wireless Communications

[selinc.com/products/communications/wireless-communications](http://selinc.com/products/communications/wireless-communications)

Wireless communications extend networks in areas where wired communications networks are not available or are cost-prohibitive. SEL wireless devices use radio signals to communicate and send data over the air, eliminating the need for traditional cabling.

## Applications

- Cellular router for remote connectivity
- Serial radio for protection schemes

## Technical Paper

Expanding Protection and Control Communications Networks With Wireless Radio Links

[selinc.com/api/download/121073](http://selinc.com/api/download/121073)

## Video

Communication Made Easy Over Difficult Terrain

[video.selinc.com/detail/video/767833630001](http://video.selinc.com/detail/video/767833630001)



## Customer Story

SCADA System Sheds Light on Texas Utility's Power System

[selinc.com/solutions/success-stories/scada-in-texas](http://selinc.com/solutions/success-stories/scada-in-texas)

## Example System Diagram

Combine SEL wireless communications devices with SEL protection, automation, and control products for a comprehensive solution.

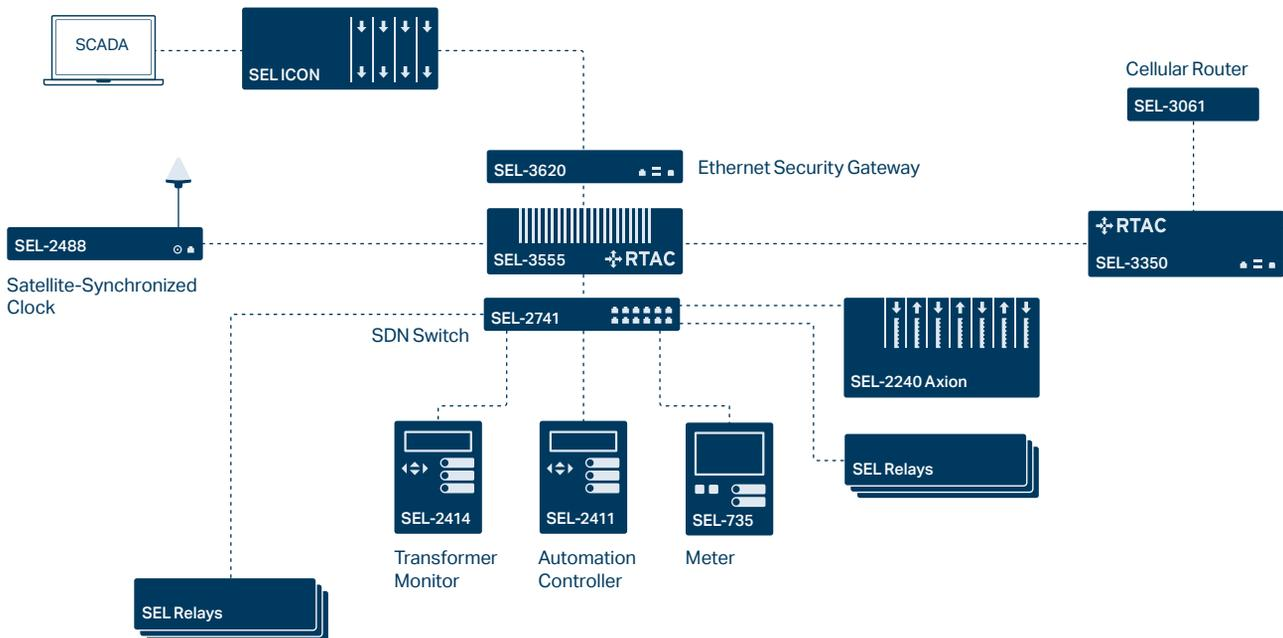



### SEL-3031 Serial Radio Transceiver

The SEL-3031 is a 900 MHz ISM serial data radio that supports point-to-point (P2P) and point-to-multipoint (P2MP) operational modes. In P2P mode, the SEL-3031 supports three serial data ports in one radio channel.



### SEL-3061 Cellular Router

The SEL-3061 provides secure, remote access for devices using public cellular radio networks. It supports 4G LTE and 3G cellular technologies.

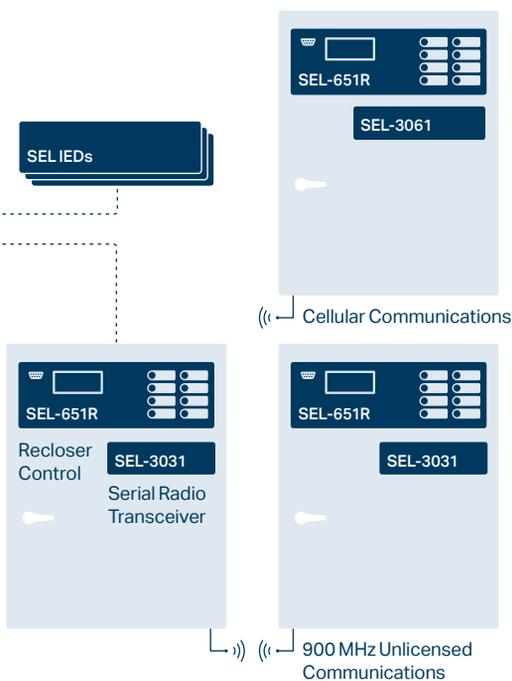

### Applications

	SEL-3031	SEL-3061
Wireless Communications for SCADA	■	■
High-Speed Teleprotection	■	
Distribution Automation	■	■
Wireless Communications for Synchrophasor Data	■	■
Substation-to-Substation Communications Link		■
Anti-Island Detection	■	■
Wireless Communications for Distributed Generation	■	■
Permanent Wireless Cable Replacement	■	■
Remote Engineering Access	■	■
Short-Range Engineering Access	■	■
LAN Extension		■
Wireless Backhaul Communications for Fault and Load Transmitters		■

### Features

915 MHz ISM Band (License-Free)	■	
Serial Communication	■	■
Ethernet Communication		■
Low Latency for Teleprotection	■	
Compatible With SEL MIRRORRED BITS® Communications	■	
Compatible With Modbus	■	■
Compatible With DNP3 and Typical Byte-Oriented Protocols	■	■
Encryption	<i>f</i>	■
Point-to-Multipoint Capability	■	
Cellular Capability		■
EIA-232 Port (Quantity)	3	1
Wired EIA-485 Port	+	
High Maximum Throughput (1 Mbps or Greater)		■
Device Status LEDs	■	■
Visible Link Quality Indicator		■

### Setup Method

USB Port	■	
Secure Web Interface Via Ethernet Port		■
Wireless Configuration	■	■
Simple Network Management Protocol (SNMP)		■

■ Standard feature + Model option

*f* With SEL-3044 Encryption Card option



# Precise Time

[selinc.com/products/communications/precise-timing](http://selinc.com/products/communications/precise-timing)

SEL precise timing solutions keep power system devices time-synchronized within a microsecond, satisfying demanding applications, like synchrophasors, Sampled Values, and traveling-wave fault locating, and ensuring that your event reports have accurate timestamps.

## Applications

- Electrical substations
- Generation facilities
- Control centers
- Industrial facilities
- Manufacturing
- Military bases
- Transportation systems

## Technical Papers

Mitigating GPS Vulnerabilities  
[selinc.com/api/download/104197](http://selinc.com/api/download/104197)

Understanding and Applying Precision Time Protocol  
[selinc.com/api/download/104199](http://selinc.com/api/download/104199)

Using Wide-Area Precise Time Distribution to Increase Dependability and Security of Substation Time Synchronization  
[selinc.com/api/download/136425](http://selinc.com/api/download/136425)



### SEL-2488 Satellite-Synchronized Network Clock

The SEL-2488 receives GNSS time signals and distributes precise time via multiple output protocols with  $\pm 40$  ns accuracy.



### SEL-2407® Satellite-Synchronized Clock

The SEL-2407 is a satellite clock with high-accuracy timing ( $\pm 100$  ns) and provides a time display.



### SEL-2401 Satellite-Synchronized Clock

The SEL-2401 is a satellite clock with high-accuracy timing ( $\pm 100$  ns) for compact spaces.



### SEL-3400 IRIG-B Distribution Module

The SEL-3400 verifies time signals and distributes precise time to 240 devices.



### SEL-3405 High-Accuracy IRIG-B Fiber-Optic Transceiver

SEL-3405 transceivers send delay-compensated demodulated IRIG-B signals up to 4 km (2.5 mi).



### SEL-9524 GNSS Antenna

The SEL-9524 is a rugged and reliable antenna for GNSS devices in critical infrastructure applications.



### SEL-3401 Digital Clock

The SEL-3401 provides a highly visible time display for use anywhere there are time-critical functions set by IRIG-B synchronization signals.



### SEL-9929 Satellite-Synchronized Clock Display Kit

The SEL-9929 kit includes a satellite-synchronized clock, a large digital clock display, and all accessories.



### SEL ICON® Integrated Communications Optical Network

The ICON provides precise time distribution over WANs, with an accuracy of 1  $\mu$ s with a variety of input and output protocols.

	SEL-2401	SEL-2407®	SEL-3400	SEL-3401	SEL ICON®	SEL-2488
<b>Applications</b>						
Time Source for Substation	■	■	■		■	■
Time Source for Industrial Applications	■	■	■		■	■
Time Source for Phasor Measurement Unit (IEEE C37.118.1-2011 Synchrophasors)	■	■	■		■	■
Time Source for Recloser	■	■				
Time Source for Line Current Differential Protection	■	■	■		■	■
Time Source for Traveling-Wave Fault Location	■	■	■		■	■
Time-Synchronized Event Reporting	■	■	■		■	■
Long-Distance Viewing, 61 m (200 ft)				■		

### Time Sources and Time Distribution

Demodulated IRIG-B Outputs (Quantity)	1	6	12	4*	4	up to 9
Modulated IRIG-B Outputs (Quantity)		1				up to 4
GPS Satellite Tracking	■	■			■	■
GLONASS Satellite Tracking (Verification Only)						■
Demodulated IRIG-B Input			■	■	■	
Synchronized Pulse Output	■	■				■
Network Time Protocol (NTP) Server						■
IEEE 1588-2008 Precision Time Protocol (PTP) (With IEEE C37.238-2011/2017 Power System and IEC/IEEE 61850-9-3:2016 Power Utility Automation Profiles)					+	+
Satellite Signal Verification						■

### Features

Large, 76.2 mm (3.0 in) Tall LED Display				■		
14 mm (0.56 in) Tall Display		■	■			■
Rack-Mount Hardware		■	■	+	■	■
Panel-Mount or Wall-Mount Hardware		■	+	■	■	+
Universal Power Supply		■	■		■	■
Dual, Redundant, Hot-Swappable Power Supplies					■	■
Power Over Ethernet (PoE) Power Sourcing Equipment (PSE)					■	
Parallel Redundancy Protocol (PRP) Support						■
Secure Web Interface for Configuration						■
Serial Ports for Configuration	■	■				
User-Based Accounts					■	■
TCXO Holdover	■	■			■	■
OCXO Holdover						+
Time-Code Cable Delay Compensation			■		■	■ <sup>1</sup>
IEEE C37.90 and IEC 60255 Surge and Environmental Standards Compliance	■	■	■	■	■	■

### Accuracy

Average Accuracy (ns)	±100	±100				±40
Peak Accuracy (ns)	±500	±500			±1,000	±100

■ Standard feature + Model option/accessory

<sup>1</sup>SEL-2488 includes antenna cable delay compensation



# Transceivers and Adapters

[selinc.com/products/communications/transceivers](http://selinc.com/products/communications/transceivers)

Many SEL devices come with standard or optional fiber-optic communications ports. Transceivers convert between copper and fiber optics or between other communications interface standards.

## Applications

- Single- or multimode fiber
- Distances ranging from 1 m (3.28 ft) to 110 km (68.35 mi)

## Related Material

Fiber-Optic Products and Applications  
[selinc.com/api/download/2848](http://selinc.com/api/download/2848)

Connector and Optics	SEL-2800	SEL-2810	SEL-2812	SEL-9220	SEL-2814	SEL-2815	SEL-2820	SEL-2824	SEL-2829	SEL-2830	SEL-2831	SEL-2894
V-Pin, 650 nm Wavelength	■	■					■					
ST, 850 nm Wavelength			■	■	■	■		■				■
ST, 1,300 nm Wavelength									■	■		
ST, 1,550 nm Wavelength											■	

## Fiber Compatibility

200 µm Core Multimode Fiber (SEL-C805)	■	■	■	■	■	■	■	■				
50 or 62.5 µm Core Multimode Fiber (SEL-C807, SEL-C808)			■	■	■	■		■				■
9 µm Core Single-Mode Fiber (SEL-C809)									■	■	■	

## Electrical Features

EIA-232 Asynchronous Serial Data	■	■	■		■	■			■	■		■
EIA-485 Asynchronous Serial Data				■			■	■				
DTE/DCE Switch					■	■			■	■	■	
IRIG-B Transfer With Data		■	■	■								
Hardware Flow Control Lines With Data					■			■				
Power From Electrical Port Pins	■	■	■	■	■	■			■	■	■	■
External Power Jack or Terminals					■		■	■				

## Distances

Minimum (metric)	1 m	1 m	1 m	1 m	1 m	2 km	1 m	1 m	1 m	16 km	16 km	1 m
Minimum (U.S.)	3.28 ft	3.28 ft	3.28 ft	3.28 ft	3.28 ft	1.24 mi	3.28 ft	3.28 ft	3.28 ft	9.94 mi	9.94 mi	3.28 ft
Maximum (metric)	500 m	500 m	4 km	4 km	4 km	15 km	500 m	4 km	23 km	80 km	110 km	2 km
Maximum (U.S.)	0.3 mi	0.3 mi	2.48 mi	2.48 mi	2.48 mi	9.3 mi	0.3 mi	2.48 mi	14.3 mi	49.7 mi	68.3 mi	1.2 mi

■ Standard feature



### **SEL-2800/2815 Fiber-Optic Transceivers**

Improve safety, signal integrity, and reliability of EIA-232 communications by using multimode SEL-2800 or SEL-2815 transceivers instead of wire.



### **SEL-2810/2812/2814 Fiber-Optic Transceivers**

Use EIA-232 multimode fiber-optic transceivers instead of wire. The SEL-2810 and SEL-2812 support IRIG-B time signals, while the SEL-2814 works with hardware flow control signals.



### **SEL-2829/2830/2831 Single-Mode Fiber-Optic Transceivers/Modems**

Apply the SEL-2829, SEL-2830, or SEL-2831 to use two optical fibers instead of wire to transfer bidirectional serial data.



### **SEL-2820/2824 Multimode Fiber-Optic EIA-485 Transceivers**

Apply an SEL-2820 or SEL-2824 to safely add isolated segments to multidrop and point-to-point EIA-485 networks.



### **SEL-2890 Ethernet Transceiver**

Add Ethernet connectivity to an SEL device using its EIA-232 serial port with the SEL-2890.



### **SEL-9192 Utility-Grade USB Modem**

Connect remote terminal units (RTUs), communications processors, and other equipment with the SEL-9192 for dial-up or dial-out engineering access.



### **SEL-9220 Fiber-Optic Adapter for SEL-300 Series Relays**

Convert the EIA-485 port of an SEL-300 series relay to a point-to-point fiber-optic port with the SEL-9220.



### **SEL-2894 Interface Converter**

Apply the SEL-2894 to transfer SEL MIRRORRED BITS® communications via an IEEE C37.94 fiber-optic link through a communications multiplexer.



### **SEL-2886 EIA-232 to EIA-485 Interface Converter**

Connect EIA-232 devices to an EIA-485 network with SEL-2886 converters.



# Cables

[selinc.com/products/cables](http://selinc.com/products/cables)

SEL manufactures high-quality cables for connecting a variety of devices. Each cable is quality-tested to ensure reliability and proper operation. Choose the cable types and lengths to match your applications using the SEL-5801 Cable Selector program.

## Applications

- GPS and radio antenna connections and IRIG-B time distribution
- Serial communications over long distances without risk of electromagnetic interference
- Adaption and connection to USB ports

## Software

SEL-5801 Cable Selector  
[selinc.com/software/downloads/?filter=SEL-5801](http://selinc.com/software/downloads/?filter=SEL-5801)

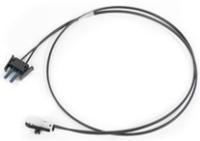

### SEL-C804 Multimode Arc-Flash Detection Fiber-Optic Cable

Use SEL-C804 cables with SEL-751 and SEL-851 Feeder Protection Relays and with SEL-710-5 Motor Protection Relays.



### SEL-C805 200 μm Multimode Fiber-Optic Cable

Connect V-pin or ST ports with SEL-C805 cable assemblies.



### SEL-C807 62.5/200 μm Multimode Fiber-Optic Cable

Use SEL-C807 cable assemblies to connect ST or LC ports.



### SEL-C808 62.5/125 μm Multimode Fiber-Optic Cable

Connect ST, SC, or LC ports with SEL-C808 cable assemblies.



### SEL-C809 9 μm Single-Mode Fiber-Optic Cables

Use SEL-C809 cable assemblies to connect ST, SC, or LC ports.



### Category 5e Ethernet

Apply high-quality, shielded twisted-pair (STP) Category 5e Ethernet cables for copper Ethernet connections.



### Coaxial Cables

Use SEL Coaxial Cables for GPS and radio antenna connections and IRIG-B time distribution.



### USB Serial Cables

Add a 1.8 m (6 ft) or 4.6 m (15 ft) EIA-232 serial port cable to a PC USB port to communicate with SEL relays and other devices with EIA-232 serial ports.



### Electrical Data Cables

Apply SEL Electrical Data Cables to reliably connect SEL products and other devices, including relays, information processors, computers, I/O modules, meters, clocks, and modems.

Connector	SEL-C804	SEL-C805Z	SEL-C805D	SEL-C805G	SEL-C807Z	SEL-C807G	SEL-C808Z	SEL-C808P	SEL-C808G	SEL-C809Z	SEL-C809P	SEL-C809G
V-Pin	■	■	■	■								
ST	■	■	■	■	■	■	■	■	■	■	■	■
LC					■	■	■	■	■	■	■	■
SC							■	■	■	■	■	■

### Fiber Diameter (Core/Outer)

1,000 μm	■											
200 μm		■	■	■								
62.5/200 μm					■	■						
62.5/125 μm							■	■	■			
9/125 μm										■	■	■

### Wavelength

650 nm (Multimode)		■	■	■								
850 nm (Multimode)		■	■	■	■	■	■	■	■			
1,300 nm (Multimode)					■	■	■	■	■			
1,300–1,550 nm (Single-Mode)										■	■	■

### Fiber Count

Simplex (1 Fiber)	■	■			■		■	■		■	■	
Duplex (2 Fibers)	■	■	■	■	■	■	■	■	■	■	■	■
Quad (4 Fibers)			■	■		■		■				

### Cable Ratings

Riser-Rated (OFNR)		■	■		■		■	■	■		■	■
Plenum-Rated (OFNP)								■			■	
Water-Blocked			■									
Waterproof				■	■			■				■

Jacket Material	SEL-C804	SEL-C805Z	SEL-C805D	SEL-C805G	SEL-C807Z	SEL-C807G	SEL-C808Z	SEL-C808P	SEL-C808G	SEL-C809Z	SEL-C809P	SEL-C809G
Polyvinyl Chloride (PVC)		■	■		■		■	■	■	■	■	■
Polyethylene (PE)	■			■		■						

### Termination Kits

V-Pin Termination Kit	■	■	■	■								
ST Termination Kit	■	■	■	■	■	■						
LC, ST, and SC Termination Kit							■	■	■	■	■	■

### Options

Bulk (No Connectors)	■	■	■	■	■	■	■	■	■	■	■	■
Pulling Loop			■	■		■			■			

### Fiber-Optic Compatibility

SEL-2800/2810/2820		■	■	■								
SEL-2812/2814/2815/2824/3405/9220		■	■	■	■	■	■	■	■			
SEL-2829/2830					■	■	■	■	■	■	■	■
SEL-2831											■	■
SEL-751/751A/710-5 Arc-Flash Detection	■											
Multimode Fiber-Optic Ethernet					■	■	■	■	■			
Single-Mode Fiber-Optic Ethernet										■	■	■

■ Standard feature



# Remote I/O

[selinc.com/products/distribution/protection/remote-i-o](http://selinc.com/products/distribution/protection/remote-i-o)

Remote I/O modules transfer data from remote locations over fiber and expand the I/O of SEL relays, automation controllers, and other devices without modification to the control panel face.

## Applications

- Provide additional I/O for SEL protective relays and information processors
- Save wiring via I/O multiplexing
- Implement teleprotection
- Improve safety with optical fiber

## Case Study

Remote I/O Modules Enable DC Substation Transfer Trip for Expanding Denver Light Rail System  
[selinc.com/api/download/2723](http://selinc.com/api/download/2723)



### SEL-2505/2506/2507 Remote I/O Module

Connect a remote I/O module to a fiber-optic port or transceiver on a protective relay to add digital I/O. Or, wire the module I/O to relay I/O to add SEL MIRRORRED BITS® teleprotection.



### SEL-2515/2516 Remote I/O Module

Connect these remote I/O modules, which are suitable for use in automation systems, to SEL information processors to easily expand inputs and outputs.



### SEL-2595 Teleprotection Terminal

Use the SEL-2595 to securely transfer teleprotection signals through a high-speed IEEE C37.94 optical-fiber interface.

	SEL-2505	SEL-2506	SEL-2507	SEL-2515	SEL-2516	SEL-2595
<b>Number of I/O Channels</b>						
Digital Inputs (DI) Base	8	8	8	8	8	8
DI Maximum	8	8	8	8	8	8
Digital Outputs (DO) Base	8	8		8	8	8
High-Speed DO Base			8			
DO Maximum	8	8	8	8	8	8

## Serial Communications Protocols

SEL MIRRORRED BITS Communications	■	■	■			
SEL Fast Messages				■	■	
IEEE C37.94						■

## Mounting

Surface/Wall Mount	■			■		
Rack Mount		+	+		+	+

■ Standard feature    + Model option



# Annunciation and Notification

[selinc.com/products/automation/operations/annunciation](http://selinc.com/products/automation/operations/annunciation)

Annunciation and notification devices provide local and remote notification to improve situational awareness, efficiency, and safety.

They display alarm conditions, and their communications ports enable integration with relays and control systems.



## SEL-2523 Annunciator Panel

Provide local and remote notifications with the SEL-2523, which includes programmable logic and up to four communications ports.



## SEL-2522 Alarm Panel

Apply the SEL-2522 with up to 36 inputs to easily view the status of alarms and operating events.



## SEL-2533 Annunciator

Use the compact, ten-window SEL-2533 to provide local and remote annunciation.

	SEL-2522	SEL-2523	SEL-2533		SEL-2522	SEL-2523	SEL-2533
<b>Applications</b>				<b>Inputs, Outputs, and HMI</b>			
Local Visual Indication	■	■	■	General-Purpose Digital Inputs	36	42	14*
Remote Visual Indication		■	■	Acknowledge, Reset, Test Digital Inputs	3	6	4*
Local Audible Indication	■	■	■	General-Purpose Digital Outputs	1	11	14*
Remote Audible Indication	■	■	■	Alarm Digital Output	1	1	1
Telephone Dial-Out Messages		■	■	General Display LEDs/Windows	36	36	10
Local SELogic® Control Equations and Time Tagging		■	■	Enabled LED	1	1	1
				Pushbuttons	3	4	4
<b>Mounting and Labeling</b>				Base Serial Ports		2	2
Rack Mount	+	+		Optional Multimode Fiber-Optic Serial Port		1	1
Panel Mount	+	+	■	Optional Additional EIA-232 or EIA-485 Port		1	1
User-Defined Slide-In Labels	■	■	■	IRIG-B Time Input		1	1
				ISA Annunciation Alarm Sequence Choices	2	8	8

### Serial Communications Protocols

SEL MIRRORING BITS® Communications		■	■
SEL Fast Messages		■	■
Send SEL Messenger Points		■	■
Modbus RTU		■	■
DNP3 Level 2 Outstation		+	+

■ Standard feature + Model option



# Software

[selinc.com/software/downloads](http://selinc.com/software/downloads) | [selinc.com/products/compass](http://selinc.com/products/compass)

SEL software products help automate and control power systems, optimize device configuration, configure secure operational technology (OT) networks, and collect and visualize power system data.

SEL Compass® keeps software applications and relay configuration drivers up to date and includes SEL instruction manuals, application guides, hardware drivers, and more.

## Webinars

Software-Based Password Rotation With DMA Credential Management  
[selinc.com/events/on-demand-webinar/137643](http://selinc.com/events/on-demand-webinar/137643)

Introducing Next-Generation FLISR Software on Blueframe  
[selinc.com/events/on-demand-webinar/136566](http://selinc.com/events/on-demand-webinar/136566)

Preventing PT Failures and Locating Generation Loss With Synchrowave® Operations  
[selinc.com/events/on-demand-webinar/136575](http://selinc.com/events/on-demand-webinar/136575)

Moving Meter Data Analysis and Reporting Into the Future  
[selinc.com/events/webinar/137463](http://selinc.com/events/webinar/137463)

## Case Study

Real-Time Operational Use Cases for Time-Synchronized Measurements With Synchrowave Operations  
[selinc.com/api/download/134864](http://selinc.com/api/download/134864)

Software Product	Configuration	Automation	Visualization and Analysis
ACSELERATOR QuickSet® SEL-5030 Software	■		
SEL Grid Configurator	■		
ACSELERATOR Architect® SEL-5032 Software	■		
ACSELERATOR RTAC® SEL-5033 Software	■		
ACSELERATOR Diagram Builder™ SEL-5035 Software	■		
ACSELERATOR® Bay Screen Builder SEL-5036 Software	■		
SEL-5056 Software-Defined Network Flow Controller	■		■
SEL-5051/5052 Client/Server Network Management System (NMS) Software	■		■
ACSELERATOR TEAM® SEL-5045 Software		■	
SEL Data Management and Automation (DMA) Blueframe Application Suite		■	
SEL Distribution Management System (DMS) Blueframe Application Suite		■	
SEL-5057 SDN Application Suite—Flow Auditor		■	
SEL-5230 ACSELERATOR Database API	■		
SEL-5231 Configuration API	■		
SEL-5073 SYNCHROWAVE Phasor Data Concentrator (PDC) Software		■	
SEL-5601-2 SYNCHROWAVE Event Software			■
SEL-5702 Synchrowave Operations Software			■
SEL-5703 Synchrowave Monitoring			■
SEL-5705 Synchrowave Reports			■

## Example System Diagram

Use SEL software solutions to optimize the configuration and management of SEL devices and networks, provide advanced automation and data collection capabilities, and offer robust tools for data visualization and analysis.

<p><b>ACSELERATOR QuickSet</b> Included with supported products</p> <p>QuickSet is a tool to configure, commission, and manage devices for power system protection, control, metering, and monitoring.</p>	<p><b>SEL Grid Configurator</b> Included with supported products</p> <p>Grid Configurator makes creating, managing, and deploying settings more efficient with its spreadsheet-style editor, protection visualization, comprehensive reporting, custom filters, and multiple-device settings management.</p>	<p><b>ACSELERATOR Architect</b> Included with supported products</p> <p>Architect streamlines the configuration and documentation of IEC 61850 messages, controls, and reports.</p>
<p><b>ACSELERATOR RTAC</b> Included with SEL RTAC purchase</p> <p>ACSELERATOR RTAC is an intuitive, easy-to-use application designed to configure the SEL Real-Time Automation Controller (RTAC) family of products, including the SEL-2240 Axion®.</p>	<p><b>ACSELERATOR Diagram Builder</b> Included with RTAC HMI purchase</p> <p>Diagram Builder enables the creation and management of HMI visualization projects for the SEL RTACs in your system.</p>	<p><b>Bay Screen Builder</b> Included with QuickSet and ACSELERATOR RTAC</p> <p>Bay Screen Builder, which works with QuickSet and ACSELERATOR RTAC, enables the custom creation of bay screens for SEL devices with touchscreen displays.</p>
<p><b>Software-Defined Network Flow Controller</b> Included with SEL software-defined networking (SDN) switch purchase</p> <p>The Flow Controller is the central interface for the commissioning, configuration, and monitoring of all SEL SDN-enabled Ethernet switches.</p>	<p><b>Client/Server Network Management System</b></p> <p>The SEL ICON® client/server NMS software helps maintain a secure, reliable, and efficient communications infrastructure.</p>	<p><b>SDN Application Suite</b></p> <p>The SDN Application Suite includes Flow Auditor, which operates with SEL-5056 to provide safe, nondisruptive audits and documentation of conversations between hosts on your critical infrastructure network.</p>

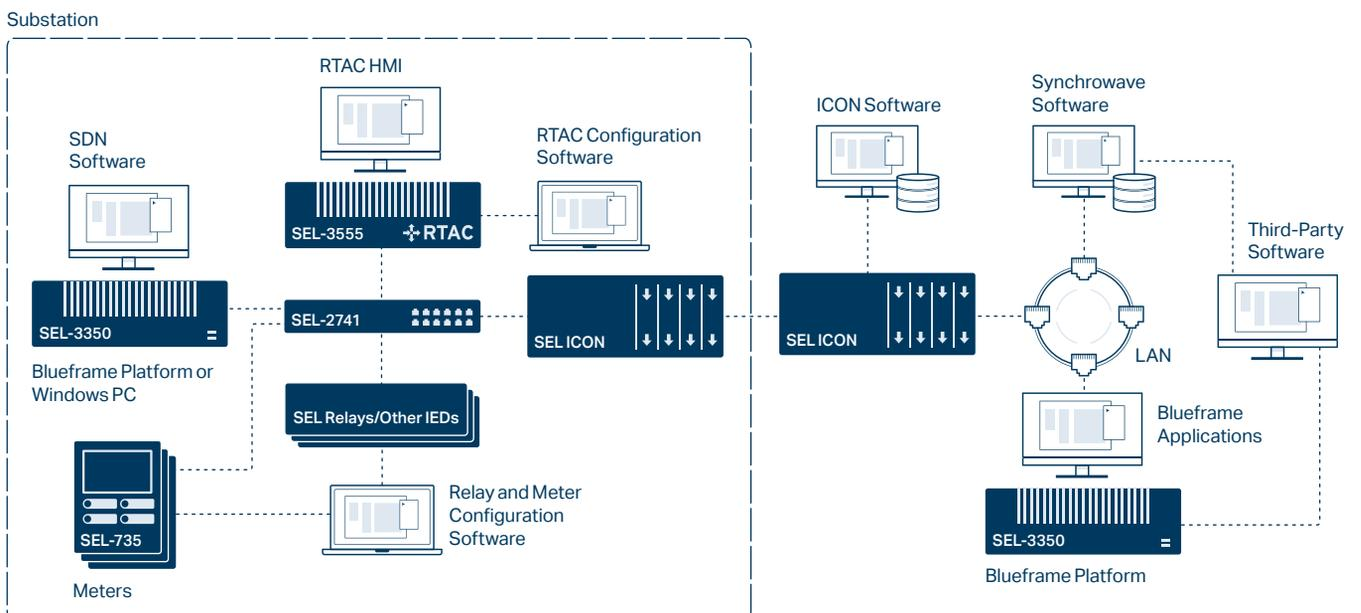

<p><b>SEL Blueframe Application Platform</b></p> <p>Scalable and flexible, SEL Blueframe provides a secure OT platform for installing applications and for managing and exchanging data between supported applications.</p>	<p><b>Data Management and Automation (DMA) Blueframe Application Suite</b></p> <p>SEL DMA applications automatically collect, store, and manage device-specific information to simplify day-to-day management of a system of devices and to support compliance efforts.</p>	<p><b>Distribution Management System (DMS) Blueframe Application Suite</b></p> <p>The DMS suite includes a FLISR (fault location, isolation, and service restoration) application package, which reduces customer outages, improves reliability metrics, and provides rapid fault detection and system restoration.</p>
<p><b>ACSELERATOR TEAM</b></p> <p>TEAM automates the collection of power system data from multiple devices and stores the data in a central location for easy access.</p>	<p><b>ACSELERATOR Database API</b></p> <p>Third-party and enterprise-level systems access ACSELERATOR TEAM data via the Database API to integrate data reporting.</p>	<p><b>SEL Configuration API</b></p> <p>This API provides an integrated approach to managing SEL device configuration data, offering read/write access to device identification information, connection parameters, passwords, and settings stored in the ACSELERATOR Database.</p>
<p><b>SYNCHROWAVE PDC</b></p> <p>SYNCHROWAVE PDC provides synchrophasor aggregation and time alignment for downstream applications and inter-entity data sharing.</p>	<p><b>SYNCHROWAVE Event</b></p> <p>SYNCHROWAVE Event displays SEL relay event reports and COMTRADE files to assist with analysis.</p>	<p><b>Synchrowave Reports</b></p> <p>Synchrowave Reports simplifies metering and power quality data reporting by analyzing stored metering data and automatically delivering scheduled reports by email.</p>
<p><b>Synchrowave Operations</b></p> <p>Synchrowave Operations increases grid safety and reliability through situational awareness with high-resolution time-series data, real-time analytics, and geographical information system (GIS) location information.</p>	<p><b>Synchrowave Monitoring</b></p> <p>Synchrowave Monitoring brings synchrophasor data and relay event reports together into one place so engineers can analyze both the high-level system impact of an event and the detailed oscillography data.</p>	<p><b>SEL RTAC HMI</b></p> <p>The SEL RTAC HMI offers an easy way to visualize data to monitor and control your system.</p>



## Accessories and Tools

[selinc.com/products/accessories](http://selinc.com/products/accessories)

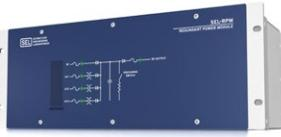

### SEL-RPM Redundant Power Module

Use the SEL-RPM to combine as many as three ac sources and one dc source to provide a single reliable dc output (unregulated 125 Vdc).



### SEL-4388 MIRRORRED BITS® Tester

Accelerate commissioning and bench testing of SEL MIRRORRED BITS links and improve training, maintenance, and cable identification with the SEL-4388.



### SEL-4520 Arc-Flash Test Module

Use the SEL-4520 to conveniently test the operation of arc-flash detection relays installed in metal-clad and metal-enclosed switchgear.



### SEL-2652 Trip Coil Monitor

Verify circuit breaker or lockout relay trip coil and trip circuit connections with the SEL-2652.



### SEL-9510 Control Switch Module

Use the SEL-9510 where independent local control is needed. High-visibility status indication and arc-suppressed contacts are ideal for breaker control.



### SEL-2126 Fiber-Optic Transfer Switch

Apply the SEL-2126 to reroute IEEE C37.94 communications for bypass breaker protection during circuit breaker or station bypass operations.



### SEL-9501 or SEL-9502 Contact Arc Suppressor

Decrease maintenance costs, increase contact reliability, and reduce destructive dc circuit overvoltages with the self-powered SEL-9501/9502 arc suppressors.



### SEL-9321 Low-Voltage DC Power Supply or SEL-9322 15 VDC Power Supply

Provide low-voltage dc power from station battery or ac sources for communications devices and accessories with SEL-9321 and SEL-9322 power supplies.



# Custom Panels and Enclosures

[selinc.com/solutions/custom-panels-enclosures](http://selinc.com/solutions/custom-panels-enclosures)

SEL designs, manufactures, tests, and delivers custom protection, control, and metering panels, control cabinets, retrofit doors, and enclosures. We integrate multiple pieces of equipment (from SEL and other manufacturers) into a single assembly or kit, enabling one-stop shopping for parts and labor with a quick turnaround time. Our experts will work with you to understand your requirements and challenges and provide innovative, economical solutions built to stringent SEL quality standards.

## Customer Stories

Partnership and Panels Improve Infrastructure

[selinc.com/highlights/rayburn-electric](http://selinc.com/highlights/rayburn-electric)

Distribution Modernization in Kentucky

[selinc.com/featured-stories/lge-ku](http://selinc.com/featured-stories/lge-ku)



## Complete Panel and Enclosure Solutions

SEL custom panel and enclosure solutions come with the following options and services:

- Consulting, engineering design, and field services.
- Panel and assembly manufacturing and testing in our in-house UL508A-certified panel shop.
- Protection, automation, and control equipment manufacturing.
- Easily extractable assemblies for all SEL-700 and SEL-2400 series products.
- Standard cabinet design for indoor and outdoor applications, including stainless steel, mild steel, aluminum, fiberglass, and polycarbonate enclosures.
- Enclosures, racks, bezels, plates, portables, swing panels, and doors.
- Seismic- and UL-certified cabinets for distribution and automation in adverse environmental conditions.



## Complete Design, Manufacturing, Testing, and Commissioning

To exactly meet your needs, we offer complete panel and enclosure solutions, from design through commissioning. We test the final implementation of every product or system before it ships, reducing your overall project costs and engineering time. This testing makes commissioning easier and faster.

## Field Services

SEL provides complete installation services during any project phase, from demolition and wiring to testing and commissioning. SEL teams have extensive safety training and provide the same level of quality customers have come to expect from SEL manufacturing and other services.

Available field services include:

- Demolition, retrofit, and upgrade of existing relay panels.
- Installation, integration, and wiring of new relay panels.
- Commissioning and testing support.
- Automation and control system installation.
- SCADA installation.
- Arc-flash solutions.
- GPS and Yagi antenna installation.
- NEMA box and electric panel installation.
- Cable installation for yard equipment through existing conduits.



# Direct-Replacement Assemblies

[selinc.com/products/7250](http://selinc.com/products/7250)

Streamline retrofit projects with SEL direct-replacement assemblies for motor, generator, transformer, feeder, and metering protection applications. These complete, preassembled retrofit kits are designed to closely match the features, form-factor, and terminal blocks of specific legacy relays. Direct-replacement assemblies combine field-proven SEL relays with specialized mounting plates, interposing terminal blocks, and other hardware to ensure quick, seamless, and cost-effective upgrades.



## Simplify Installation and Configuration

Direct-replacement assemblies deliver an installation experience that is easy, fast, and error-free. The physical installation work for each unit can be completed within an hour—without any power tools. Panel cuts and drilling are not required; instead, each assembly fits the existing panel opening and mounting holes. Terminal block arrangements and wiring designations closely match legacy products, and SEL provides wiring marking labels with all retrofit kits.

## Minimize Engineering Work

Eliminate time-intensive and costly engineering tasks, such as revising drawings and diagrams. All assembly kits include wiring diagrams, so existing documentation for your system is not required for installation.

## Partner With SEL on a Turnkey Solution

We offer complete design, installation, and commissioning services for retrofit projects, saving you time and reducing costs.

Manufacturers we offer direct-replacement assemblies for include:

- GE
- Westinghouse
- Cutler-Hammer
- Eaton
- Square D
- ABB
- Siemens



# Engineering Services

[selinc.com/engineering-services](http://selinc.com/engineering-services) | [esinfo@selinc.com](mailto:esinfo@selinc.com)

With a history of support and partnership involving projects throughout the world, SEL Engineering Services offers turnkey solutions for power system protection, automation, communications, and control. Every solution is custom-engineered with an array of field-proven SEL products. All SEL products are backed by our ten-year warranty and 24/7 emergency technical support.

Our local engineering teams provide consulting services and specialized solutions for projects of any scale, ranging from retrofits and upgrades to microgrids and nation-wide power systems. Offering onsite and remote support, SEL Engineering Services is your partner throughout the entire process—from design and testing to commissioning and maintenance.

## Featured Services and Solutions

### Substation Automation, Protection, and Control Solutions

Our engineers leverage their expertise in advanced relay and automation technology to design, test, and implement comprehensive substation solutions. They offer complete protection systems and scalable automation solutions for generation, transmission, and distribution applications—as well as a range of services to support your ongoing substation improvements.

### Power Management and Microgrid Control Solutions

POWERMAX® Power Management and Control Systems intelligently balance generation and load at subcycle speeds to maintain grid stability, prevent widespread outages, and reduce energy costs. These solutions are designed for a variety of applications, including industrial power management systems, remedial action schemes for utilities, and microgrid control systems for commercial, military, and mobile microgrids.

### Cybersecurity Services

Our cybersecurity specialists offer an array of products and services to help you develop more secure networks for your operational technology (OT) systems. They provide site vulnerability assessments, comprehensive mitigation strategies, and streamlined solutions for maintaining regulatory compliance and managing system security.

### Additional Offerings

- NERC CIP compliance
- Substation engineering services
- SCADA systems and substation HMIs
- Distribution network automation
- Wide-area monitoring systems (WAMS)
- Arc-flash solutions
- Remote terminal unit (RTU) replacements
- Digital fault recording (DFR) systems
- System modeling and studies
- Design and drafting services
- Civil engineering services





# Ordering

## Online Configuration and Ordering

Configure products to meet your exact application needs and order them online with an SEL account. Once logged in, select “Configure and Order” on a product webpage to choose from available model options, including items like power supply voltages, inputs and outputs, communications ports and protocols, and conformal coating. Save individual products to your cart, create projects to house specific product orders, and request a quote—all online. For products that do not require configuration or have been identified as common product configurations, select “Popular Models” on a product webpage to quickly and easily find the model you want.

## Ordering Support

Our sales representatives and customer service teams are always happy to answer questions and help configure the right SEL solution for your application. See pages 70–71 for regional sales contact information, or visit [selinc.com/support](http://selinc.com/support).

## Popular Models

The Popular Models program makes selecting and ordering SEL products simple, fast, and convenient. SEL popular models are products preconfigured for popular applications and available for many SEL devices. Specific popular models may ship from stock. When available, the popular model configurations are displayed on the related SEL product webpage, where you can also view their technical details and popular applications. You can order these models directly from SEL or through your SEL sales representative.





## Education and Training

### Online Technical Resources

Get access to secure product information, configure and order products, and register for trainings with an SEL account. Head to [selinc.com](http://selinc.com) and click "Login" at the top right corner of your screen. You'll be able to:

- Access secure product information, like application guides and instruction manuals.
- Watch recorded webinars.
- View on-demand virtual presentations.
- Register for regional seminars and SEL University courses.

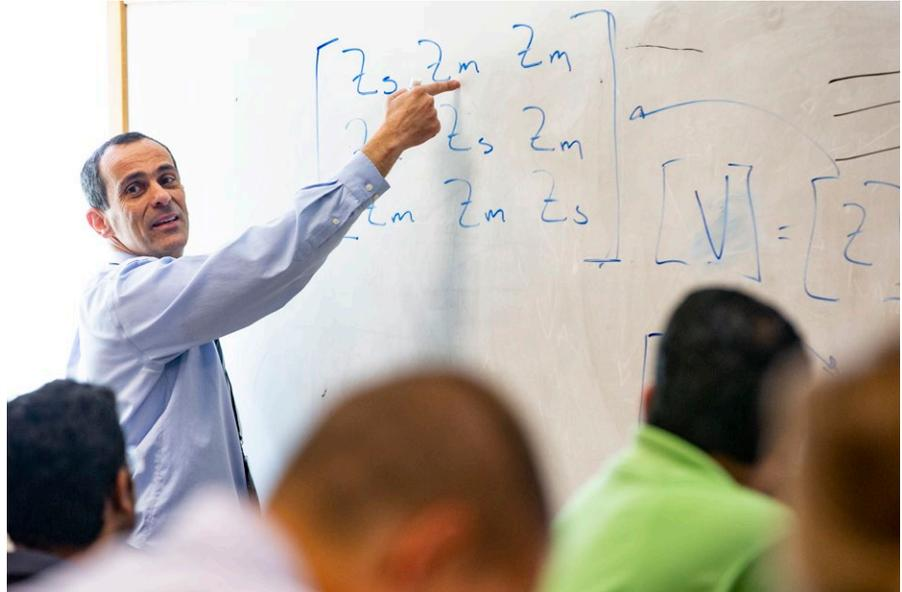

### Schweitzer Drive Podcast

Our "Schweitzer Drive" podcast explores what goes on between the generation of electricity and the light switch. In each episode, SEL CEO Dave Whitehead talks with the entrepreneurs, innovators, and experts who are inventing the future of electric power. Visit [selinc.com/company/podcast](http://selinc.com/company/podcast) to listen.

### SEL University

Learn about power system fundamentals, the physics of power system protection, and advanced product applications with courses from SEL University. Gain Professional Development Hours (PDHs) and the confidence to install and commission SEL protection, automation, and control products. Our flexible learning format includes virtual, on-demand, and in-person classes that are taught by the same engineers who design SEL equipment and solutions, support customers, and author industry publications. Our power system experts have trained tens of thousands of industry professionals worldwide to help them meet the technical challenges of integrating digital technologies into their expanding power system infrastructure.

SEL University covers topics such as:

- Introduction to SEL relays.
- Cybersecurity and securing operational technologies (OT) networks.
- SEL Real-Time Automation Controller (RTAC) applications.
- Protecting power systems for engineers.

See available courses and register at [selinc.com/selu](http://selinc.com/selu).

## Technical Papers, Webinars, and Videos

SEL power system experts have authored more than 1,000 technical papers, hosted hundreds of webinars, and developed dozens of support videos. They are dedicated to teaching about how our technologies solve complex power system challenges and about how we partner with our customers to solve tough problems. Head to [selinc.com](https://selinc.com) to access our library of educational material, including these trending and top five downloaded technical papers:

## Trending Technical Papers

Case Study: High-Density Distribution Coordination Using High-Speed Communications

[selinc.com/api/download/130375](https://selinc.com/api/download/130375)

Energy Packets With Application to Voltage Stability Assessment and Control

[selinc.com/api/download/137039](https://selinc.com/api/download/137039)

Using Software-Defined Networking to Build Modern, Secure IEC 61850-Based Substation Automation Systems

[selinc.com/api/download/130126](https://selinc.com/api/download/130126)

Case Study: Integrating and Stabilizing Renewable Energy on a Transmission Line Using Multiple Wind and Solar Farms

[selinc.com/api/download/137525](https://selinc.com/api/download/137525)

Cyber Vulnerability Assessment of a Digital Secondary System in an Electrical Substation

[selinc.com/api/download/133819](https://selinc.com/api/download/133819)

## Top Five Downloaded Technical Papers of 2022

Fundamentals and Advancements in Generator Synchronizing Systems

[selinc.com/api/download/9145](https://selinc.com/api/download/9145)

Current Transformer Accuracy Ratings

[selinc.com/api/download/3684](https://selinc.com/api/download/3684)

Review of Ground Fault Protection Methods for Grounded, Ungrounded, and Compensated Distribution Systems

[selinc.com/api/download/2604](https://selinc.com/api/download/2604)

Considerations for Using High-Impedance or Low-Impedance Relays for Bus Differential Protection

[selinc.com/api/download/5562](https://selinc.com/api/download/5562)

Introduction to Symmetrical Components

[selinc.com/api/download/2470](https://selinc.com/api/download/2470)

## Bookstore

Visit the SEL bookstore at [selinc.com/bookstore](https://selinc.com/bookstore) for focused, technical paper anthologies, like the following:

- Modern Solutions for Protection, Control, and Monitoring of Electric Power Systems
- Synchronous Generator Protection and Control
- Line Current Differential Protection
- Locating Faults and Protecting Lines at the Speed of Light

*Modern Solutions for Protection, Control, and Monitoring of Electric Power Systems* offers a comprehensive reflection of technologies developed by SEL engineers and spans topics of interest to people working in protection, control, communications, regulation, education, and design.

Online you'll also find these books written by Stanley E. Zocholl, an SEL Distinguished Engineer and IEEE Life Fellow:

- Analyzing and Applying Current Transformers
- AC Motor Protection





# Customer Support

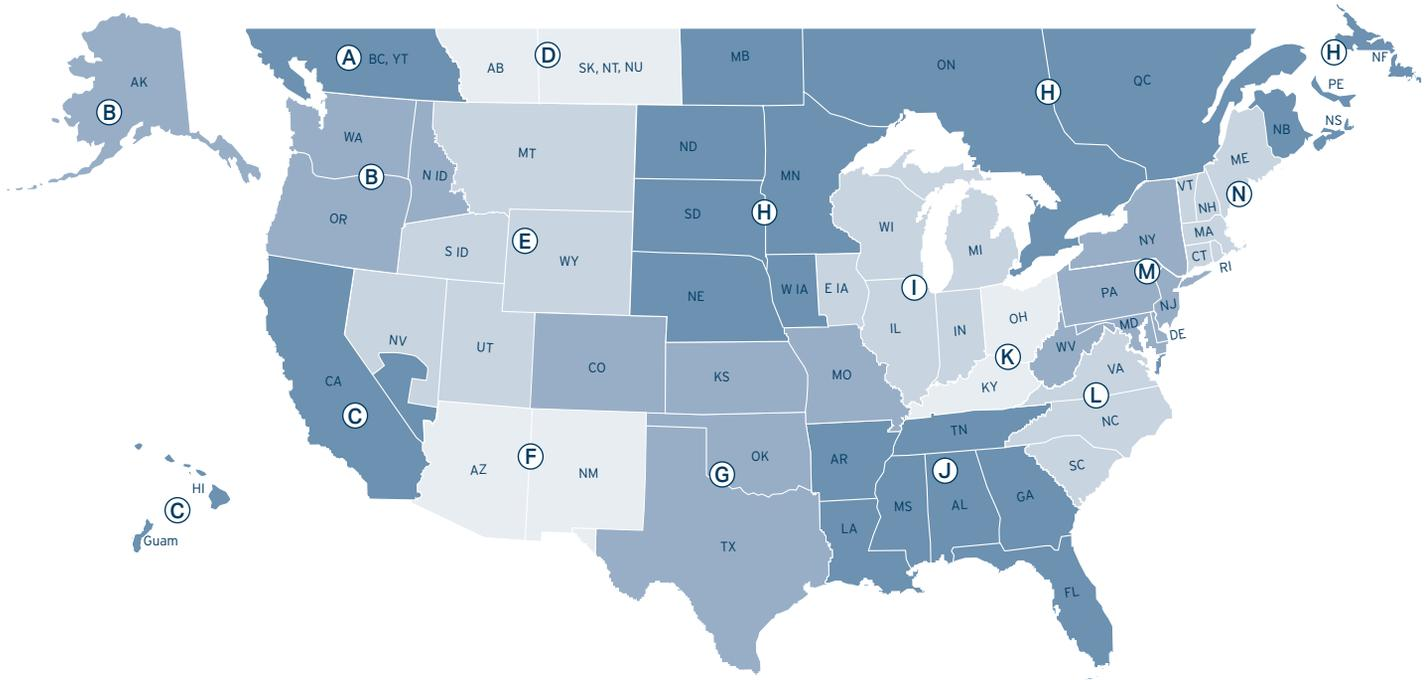

## United States and Canada Sales Contact Information

<b>A</b> <b>British Columbia Territory</b> Tel: +1.509.334.5542 nw_quotes@selinc.com selinc.com/support	<b>F</b> <b>Arizona Sun Sales, Inc.</b> Tel: +1.602.437.0469 sales@arizonasunsales.com arizonasunsales.com	<b>K</b> <b>Utility &amp; Industrial Products, Inc.</b> Tel: +1.888.520.6231 sales@uandiprducts.com uandiprducts.com
<b>B</b> <b>Peak Measure, Inc.</b> Tel: +1.360.263.0123 orders@peakmeasure.com peakmeasure.com	<b>G</b> <b>KD Johnson, Inc.</b> Tel: +1.903.587.3373 sales@kdjinc.com kdjinc.com	<b>L</b> <b>Atlantic Power Sales, LLC</b> Tel: +1.704.812.8694 sales@atlanticpowersales.com atlanticpowersales.com
<b>C</b> <b>Matzinger-Keegan, Inc.</b> Tel: +1.949.852.1006 sales@mkireps.com mkireps.com	<b>H</b> <b>Pro-Tech Power Sales, Inc.</b> Tel: +1.651.633.0573 sales@pro-techpower.com pro-techpower.com	<b>M</b> <b>Mid-Atlantic Territory</b> Tel: +1.509.332.1890 sel_nequotes@selinc.com selinc.com/support
<b>D</b> <b>PowerNet Measurement &amp; Control, Ltd.</b> Tel: +1.403.571.4735 powernet@powernet-mcl.com powernet-mcl.com	<b>I</b> <b>A Star Electric Co.</b> Tel: +1.847.439.4122 support@astareg.com astareg.com	<b>N</b> <b>New England Territory</b> Tel: +1.509.332.1890 sel_nequotes@selinc.com selinc.com/support
<b>E</b> <b>Rocky Mountain Territory</b> Tel: +1.509.336.2666 nw_quotes@selinc.com selinc.com/support	<b>J</b> <b>Power Connections, Inc.</b> Tel: +1.334.702.6650 info@powerconnections.com powerconnections.com	

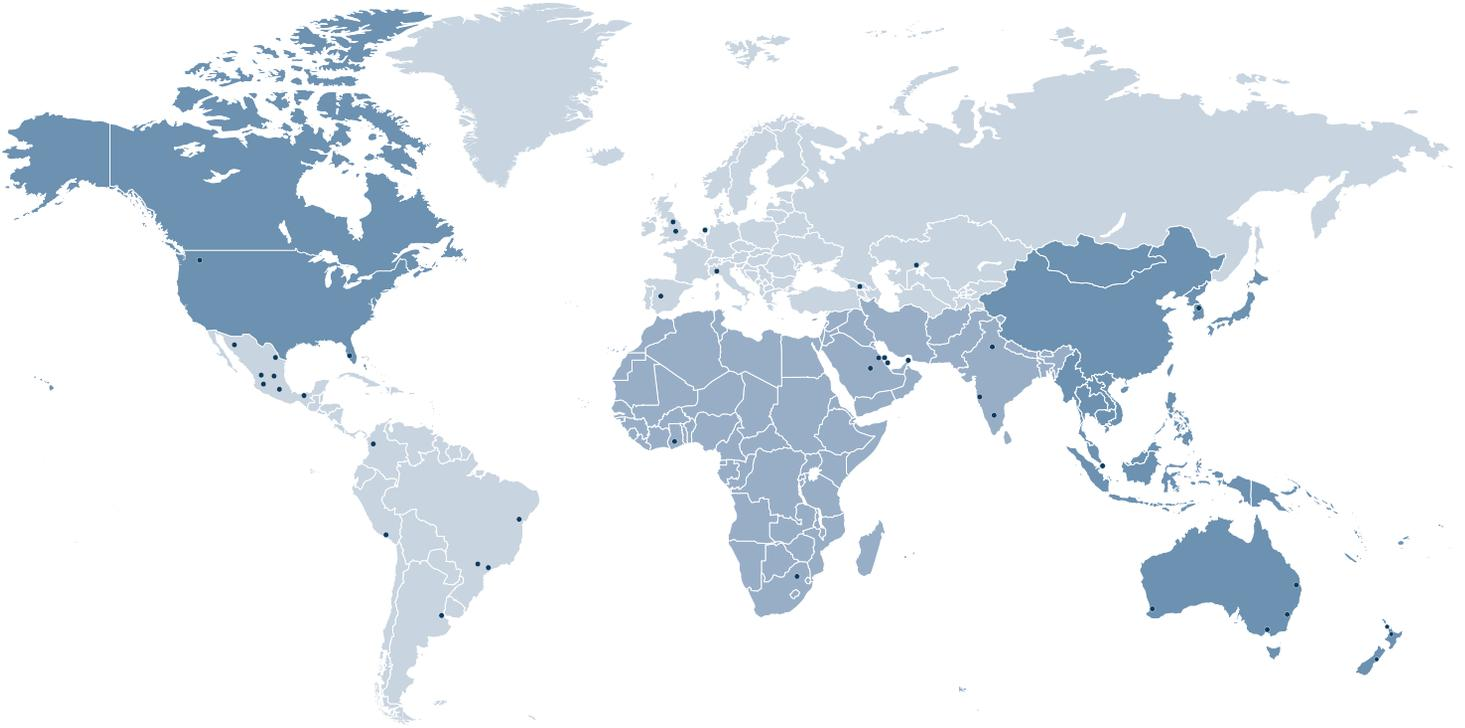

## Global Sales Contact Information

### Primary Support Location

### Tech Support

### Sales Support

#### Asia Pacific

Australia   Perth	apac_support@selinc.com   +61.3.7064.3308	OrdersAUNZ@selinc.com
Northeast and Southeast Asia   Singapore	apac_support@selinc.com   +61.3.7064.3309	SEL_SoutheastAsia@selinc.com
New Zealand   Auckland	apac_support@selinc.com   +61.7.3903.9692	OrdersAUNZ@selinc.com

#### Europe and Eurasia

Eurasia   Tbilisi, Georgia	Europe_TechSupport@selinc.com   +44.20.4551.8749	SEL_Eurasia@selinc.com
Northern Europe   Stafford, U.K.	Europe_TechSupport@selinc.com   +44.20.4551.8749	SEL_NorthernEurope@selinc.com
Southern Europe   Milan, Italy	Europe_TechSupport@selinc.com   +39.23.0565490	SEL_SouthernEurope@selinc.com

#### India, Middle East, and Africa (IMEA)

India   Bangaluru	india_support@selinc.com   +18000010188	SEL_India@selinc.com
Middle East and North Africa   Manama, Bahrain or Dubai, UAE	middleeast_support@selinc.com   +973.1752.7719	ME-CS@selinc.com
South Africa   Centurion, South Africa	support-africa@selinc.com   +27.12.750.4344	SEL_SouthAfricaOrders@selinc.com

#### Latin America

Mexico   San Luis Potosi	soporte@selinc.com   +52.800.123.0452	SEL_Mexico@selinc.com
Central America and Caribbean   Trinity, FL	support_caribbean@selinc.com   +1.509.338.3838	SEL_LatinAmerica@selinc.com
South America   Bogota, Colombia	soporte@selinc.com   +51.800.7522.577	SEL_LatinAmerica@selinc.com
Brazil   Campinas	suporte@selinc.com   +55 (19) 3515.2010	vendas@selinc.com

#### USA and Canada

Pullman, WA	selinc.com/support   +1.509.338.3838	selinc.com/support
-------------	--------------------------------------	--------------------



# Index

300G Generator Relay	12	751 Feeder Protection Relay	15,30	2800 Fiber-Optic Transceiver	55
311C Transmission Protection System	20	787-2/-3/-4 Transformer Protection Relay	16,24	2810 Fiber-Optic Transceiver With IRIG-B	55
311L Line Current Differential Protection and Automation System	20	787Z High-Impedance Differential Relay <b>NEW</b>	16,24	2812 Fiber-Optic Transceiver With IRIG-B	55
351 Protection System	30	849 Motor Management Relay	15	2814 Fiber-Optic Transceiver With Hardware Flow Control	55
351A Protection System	30	851 Feeder Protection Relay	15,30	2815 Fiber-Optic Transceiver/Modem	55
351RS Kestrel® Single-Phase Recloser Control	32	2126 Fiber-Optic Transfer Switch	63	2820 Multimode Fiber-Optic EIA-485 Transceiver	55
351S Protection System	30	2240 Axion®	42	2824 Multimode Fiber-Optic EIA-485 Transceiver	55
352 Breaker Failure Relay	24	2401 Satellite-Synchronized Clock	52	2829 Single-Mode Fiber-Optic Transceiver/Modem	55
387L Line Current Differential Relay	20	2407® Satellite-Synchronized Clock	52	2830 Single-Mode Fiber-Optic Transceiver/Modem	55
400G Advanced Generator Protection System	12	2411 Programmable Automation Controller	42	2831 Single-Mode Fiber-Optic Transceiver/Modem	55
401 Protection, Automation, and Control Merging Unit	24	2411P Pump Automation Controller	42	2886 EIA-232 to EIA-485 Interface Converter	55
411L Advanced Line Differential Protection, Automation, and Control System	20	2414 Transformer Monitor	24	2890 Ethernet Transceiver	55
421 Protection, Automation, and Control Merging Unit	24	2431 Voltage Regulator Control	32	2894 Interface Converter	55
421 Protection, Automation, and Control System	20	2440 DPAC Discrete Programmable Automation Controller	42	3025 Serial Shield®	48
451 Protection, Automation, and Bay Control System	30	2488 Satellite-Synchronized Network Clock	52	3031 Serial Radio Transceiver	51
487B Bus Differential and Breaker Failure Relay	24	2505 Remote I/O Module	58	3061 Cellular Router	51
487E Transformer Protection Relay	24	2506 Rack-Mount Remote I/O Module	58	3350 Computing Platform <b>NEW</b>	16,41
487V Capacitor Protection and Control System	24	2507 High-Speed Remote I/O Module	58	3355 Computing Platform	41
501 Dual Universal Overcurrent Relay	30	2515 Remote I/O Module	58	3360E Compact Computing Platform	41
551 Overcurrent/Reclosing Relay	30	2516 Rack-Mount Remote I/O Module	58	3360S Compact Computing Platform	41
551C Overcurrent/Reclosing Relay	30	2522 Alarm Panel	59	3390 PCIe Adapter Cards	42
587Z High-Impedance Differential Relay	16	2523 Annunciator Panel	59	3400 IRIG-B Distribution Module	52
651R Advanced Recloser Control	32	2533 Annunciator	59	3401 Digital Clock	52
651RA Recloser Control	32	2595 Teleprotection Terminal	58	3405 High-Accuracy IRIG-B Fiber-Optic Transceiver	52
700BT Motor Bus Transfer Relay	15	2600 RTD Module	12,16	3505 Real-Time Automation Controller (RTAC)	42
700G Generator Protection Relay	12,15	2652 Trip Coil Monitor	63	3505-3 RTAC	42
710-5 Motor Protection Relay	15	2664 Field Ground Module	12	3530 RTAC	41
734B Advanced Monitoring and Control System	32	2664S Stator Ground Protection Relay	12	3530-4 RTAC	41
734W Capacitor Bank Control	32,35	2725 Five-Port Ethernet Switch	48	3555 RTAC	16,41
735 Power Quality and Revenue Meter	16,38	2730M Managed 24-Port Ethernet Switch	48	3560E RTAC	41
		2730U Unmanaged 24-Port Ethernet Switch	48	3560S RTAC	41
		2740S Software-Defined Network Switch	48		
		2741 Ethernet Switch	48		
		2742S Software-Defined Network Switch	16,48		

3610 Port Server	48	AR Overhead AutoRANGER® Fault Indicator	35	RadioRANGER® Underground Wireless Fault Indication System	36
3620 Ethernet Security Gateway	48	AR360 Overhead AutoRANGER® Fault Indicator	35	RP50 Fault Repeater	30
3622 Security Gateway	48	ARU Underground AutoRANGER® Fault Indicator	36	RPM Redundant Power Module	63
3780 Test Point Voltage Sensor	36	Blueframe® Application Platform	42,62	RTAC HMI	42,62
4388 MIRRORING BITS® Tester	63	Blueframe® DMA Application Suite <b>NEW</b>	42,62	SCT Submersible Separable-Core Current Transformer	37
4520 Arc-Flash Test Module	63	Blueframe® DMS Application Suite	42,62	SR Underground Secondary/Low-Voltage Reset Fault Indicator	36
5030 ACSELERATOR QuickSet® Software	61	C804 Multimode Arc-Flash Detection Fiber-Optic Cable	56	T400L Time-Domain Line Protection	20
5032 ACSELERATOR Architect® Software	61	C805 200 µm Multimode Fiber-Optic Cable	56	T401L Ultra-High-Speed Line Relay	20
5033 ACSELERATOR RTAC® Software	61	C807 62.5/200 µm Multimode Fiber-Optic Cable	56	T4287 Traveling-Wave Test System	20
5035 ACSELERATOR Diagram Builder™ Software	61	C808 62.5/125 µm Multimode Fiber-Optic Cable	56	TMU TiDL® Merging Unit	24
5036 ACSELERATOR® Bay Screen Builder Software	61	C809 9 µm Single-Mode Fiber-Optic Cables	56	TPR Underground Test Point Reset Fault Indicator	36
5037 Grid Configurator Software	61	Cables—Coaxial, Electrical Data, Ethernet, and USB	56	TR Underground Timed-Reset Fault Indicator	36
5045 ACSELERATOR TEAM® Software	62	CR Underground Current Reset Fault Indicator	36	VIN Voltage Indicator	37
5051/5052 Client/Server Network Management System (NMS) Software	61	CT Split-Core Current Transformers	37	Wireless Protection System	30,35
5056 Software-Defined Network Flow Controller	61	Direct-Replacement Assemblies	65		
5057 SDN Application Suite	61	ER Overhead Electrostatic Reset Fault Indicator	35		
5073 SYNCHROWAVE® PDC Software	62	FLR Fault and Load Receiver	35		
5230 ACSELERATOR® Database API	38,62	FLT Fault and Load Transmitter	35		
5231 SEL Configuration API	62	FR12 Fault Receiver	30		
5601-2 SYNCHROWAVE® Event Software	62	FT50 Fault Transmitter	30		
5702 Synchronwave® Operations	62	GFD Underground Ground Fault Detector	16		
5703 Synchronwave® Monitoring	62	HZM High-Impedance Module <b>NEW</b>	16,24		
5705 Synchronwave® Reports	38,62	ICON® Integrated Communications Optical Network	48,52		
9192 Utility-Grade USB Modem	55	LINAM® Wireless Current Sensor	32,35		
9220 Fiber-Optic Adapter for 300 Series Relays	55	MOTORMAX® Low-Voltage Motor Management and Protection System	17		
9321 Low-Voltage DC Power Supply	63	MR Manual Reset Fault Indicator	37		
9322 15 VDC Power Supply	63	PILC Underground Paper-Insulated Lead-Covered Cable Fault Indicator	36		
9501 Contact Arc Suppressor	63	POWERMAX® Power Management and Control Systems	17		
9502 Contact Arc Suppressor	63				
9510 Control Switch Module	63				
9524 GNSS Antenna	52				
9929 Satellite-Synchronized Clock Display Kit	52				

The information in this document is furnished for informational use only and is subject to change without notice. Drawings are for illustrative purposes only; they are not for construction. Schweitzer Engineering Laboratories, Inc., is also referred to in this catalog as Schweitzer Engineering Laboratories. All brand or product names appearing in this document are the trademark or registered trademark of their respective holders in the U.S. and other countries. No SEL trademarks may be used without written permission. SEL products appearing in this document may be covered by U.S. and Foreign patents.

EtherCAT® is a registered trademark and patented technology, licensed by Beckhoff Automation GmbH, Germany.

© 2023 by Schweitzer Engineering Laboratories, Inc. All rights reserved.



2350 NE Hopkins Court, Pullman, WA 99163 USA

+1.509.332.1890

[info@selinc.com](mailto:info@selinc.com)

[selinc.com](http://selinc.com)