

# Voltage Transformer Failure Prediction With Synchrophasor Data

Matthew Rhodes,  
*Salt River Project*

Md Arif Khan, Joshua Wold, Greg Zweigle, and Jared Bestebreur  
*Schweitzer Engineering Laboratories, Inc.*

Presented at the  
49th Annual Western Protective Relay Conference  
Spokane, Washington  
October 11–13, 2022

Originally presented at the  
25th Annual Georgia Tech Fault and Disturbance Analysis Conference, May 2022

# Voltage Transformer Failure Prediction With Synchrophasor Data

Matthew Rhodes, *Salt River Project*

Md Arif Khan, Joshua Wold, Greg Zweigle, and Jared Bestebreuer, *Schweitzer Engineering Laboratories, Inc.*

**Abstract**—A voltage transformer (VT) steps down high voltage from the grid to a lower level that is appropriate for metering, protection, and control devices, and a failure in a VT circuit affects the functionality of any devices that are connected to it. A protective relay uses measured voltages to correctly determine if a fault is within the zone of protection and to calculate the fault location. Corrupt voltage measurements can impact the protective functionalities of power system relays. For example, a relay can overreach, restrain from operation, or make incorrect directional decisions when it operates based on corrupted measurements. Causes of bad measurements can include a failing VT, bad fuse, or fault in the circuit electronics.

Some relays include logic to monitor for a loss of voltage (i.e., loss-of-potential logic). However, a protective relay is not necessarily designed to include sophisticated analytics on the degradation of voltage signals, especially in the early stages of degradation, when the corruptions are small, intermittent, and random in nature. In contrast, a software system can monitor long-term signatures for incipient VT circuit failure and make predictions of impending failures. This paper presents a novel, synchrophasor-measurement-based algorithm that can detect faulty VT circuits weeks before failure. The algorithm is also capable of indicating which phase is failing, and capable of providing alarms to power system operators in near-real time. This is valuable to power system owners, because they can repair or replace failing VT circuits before the failures lead to significant damage to system assets. The algorithm was tested using field-measured synchrophasor data, and the results are presented in this paper.

## I. INTRODUCTION

The accuracy of voltage measurements is critical for power system protection, operation, and control. Distance relays can overreach, false trip, or make incorrect directional decisions when they operate on erroneous voltage measurements [1]. Erratic voltage measurements can influence the voltage and frequency algorithms of protective relays and phasor measurement units (PMUs) and can cause errors in voltage phasor estimates [1] [2]. Voltage magnitude errors can cause false alarms in the voltage-monitoring modules in control centers. Voltage measurement errors can result in shifts in the voltage angles, which can create false alarms in the phase angle difference and system stress-monitoring modules that are typically used in power system operation and control centers.

Voltage measurement errors can emanate from an aging voltage transformer (VT), failing fuses, or faults in the voltage measurement circuit. Material degradation, reduction in dielectric strength, and corroded spark gaps in a coupling-capacitor voltage transformer (CCVT) can result in slight errors in secondary voltage, corrupted voltage signals, or a total loss

of voltage [1]. The advantages of early detection are substantial. Detecting a failing component late can result in urgent replacement scheduling, which is inefficient and increases maintenance costs. Furthermore, if the detection method only detects outright failure, the result can be costly equipment damage and injury to personnel [3]. Early detection and efficient repair scheduling can reduce the duration of time that a VT is out of service and the associated duration when certain protection functionality is disabled.

Some relays include loss-of-potential (LOP) logic to detect a loss of voltage when the voltage magnitude starts to drop at a faster rate (typically, cycle-to-cycle, a ten-percent drop from nominal) [4]. However, this logic is not designed to effectively detect errors that are small in scale or that develop gradually. When LOP logic alarms, the alarms are not necessarily sent to a control room in near-real time for operators. As synchrophasor measurements become more available in control rooms, algorithms for detecting impending VT circuit failure can bring significant benefit to power system monitoring, operation, control, and management without any additional system upgrade efforts.

This paper presents a novel algorithm to detect impending VT circuit failure. The algorithm identifies which phase is failing. Section II discusses the algorithm in detail. Section III presents two real-world VT circuit failure cases and discusses the algorithm results. Final conclusions are drawn in Section IV.

## II. DETECTION ALGORITHM

### A. Algorithm Motivation

When there is an impending failure in the VT circuit, such as a degrading fuse, data show that it tends to generate relatively small, random, and intermittent excursions of the measurements from a steady state [5]. For failing fuses, these excursions present as small voltage drops and erratic phase-angle changes in PMU measurements. Although PMU algorithms extensively filter time-domain voltage waveforms, PMU output is sufficient for failure detection.

When one phase is failing and the others are not, these excursions are present only in the measurements from the failing phase circuit. When multiple phase circuits start to develop an impending failure, the excursions are likely to be uncorrelated between one phase and another at a particular instant. The novel system described in this paper was developed to detect such an intermittent, phase-to-phase-uncorrelated response, in addition to random phase-angle changes during the

incipient stage. The system has three main components: preprocessing of synchrophasor measurements, failure detection in the incipient stage from the preprocessed signals, and postprocessing of the detection results for alarm generation that suits a control room environment.

### B. Preprocessing

The phase voltage magnitudes ( $V_\phi$ ) are converted into per-unit (pu) values to make downstream processing independent of the different voltage levels in a power system. Any frequency deviation from nominal is calculated by taking the derivative of the phase voltage angles ( $\theta_\phi$ ). Outliers in measured data that result from communication errors, PMU synchronization errors, or fast transients are filtered using a median filter. Linear interpolation is used to reconstruct missing and bad samples. The overall preprocessing stage process is shown in Fig. 1. In the figure,  $V_{\phi,PP}$  and the phase derivative,  $\theta'_{\phi,PP}$ , represent the preprocessed phase voltage magnitude and the derivative of phase voltage angles that are used for the failure detection process.

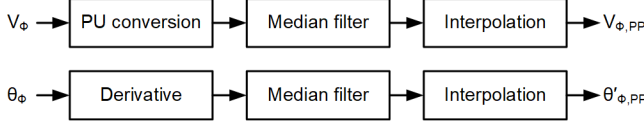

Fig. 1. Preprocessing of all three phases, with  $\phi$  representing A-, B-, and C-phases,  $V_\phi$  representing voltage magnitudes, and  $\theta_\phi$  representing angles.

### C. Failure Detection

The preprocessed signals  $V_{\phi,PP}$  and  $\theta'_{\phi,PP}$  are used to detect impending VT failure. Fig. 2 shows the overall detection process. The preprocessed signals are filtered using a low-pass filter (LPF) with infinite impulse response (IIR) to estimate a slowly varying, time-delayed ambient response of the system. The filtered signal is subtracted from the corresponding preprocessed signal. The resulting phase-error signals  $\epsilon_\phi$  and  $\epsilon'_\phi$  (see Fig. 2) have the following important characteristics:

- Any slowly varying ambient process is removed.
- Phase imbalances are removed.
- The signature of random voltage drops due to the failure in a VT circuit is enhanced.

The subtracted signals are then used to compute phase-to-phase errors  $\epsilon_{\phi_1\phi_2}$  and  $\epsilon'_{\phi_1\phi_2}$  in the measurements. At a particular instant, if some phase is failing while the others are healthy, the phase-to-phase errors clearly show the failing signature. The voltage drop in all three phases is treated as a typical operation in the power system, such as the starting of a large industrial motor, because the design assumes no common-cause failure modes. Therefore, correlated changes in all three phases are removed in the phase-to-phase error signals.

The resulting phase-to-phase error signals  $\epsilon_{\phi_1\phi_2}$  and  $\epsilon'_{\phi_1\phi_2}$  are noisy; therefore, they are filtered using an LPF with finite impulse response (FIR) for a moderate level of smoothing. A well-designed IIR LPF with an approximately linear phase response can also be used. However, FIR LPFs are preferred, because they have linear phase responses with constant group delays. These reduce the risk of artificial peaks due to different

time delays in different signals, which can lead to false detection.

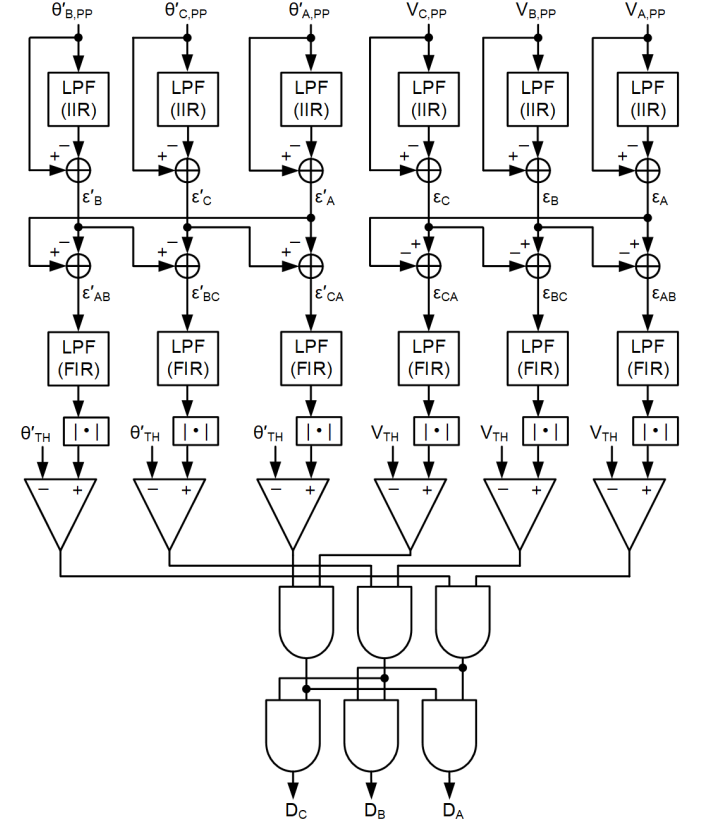

Fig. 2. Impending VT failure detection process.

The absolute values of the phase-to-phase error signals  $\epsilon_{\phi_1\phi_2}$  and  $\epsilon'_{\phi_1\phi_2}$  are compared against preset thresholds  $V_{TH}$  and  $\theta'_{TH}$  (for the magnitude and derivative of angle signals, respectively), to generate digital signals. When the digital signal is high, it is likely that one of the corresponding phases is failing.

When there is a failure in a VT phase circuit, the failure manifests in both voltage magnitude and angle measurements from that phase. This is because the failure is represented as distortion in the instantaneous voltage signal. If, however, the signal remains sinusoidal, but changes in amplitude, then the VT magnitude changes and the phase angle does not change. This type of distortion is not consistent with a failing VT signal.

The synchrophasors are estimated from time-domain signals that are heavily filtered to attenuate all frequency components other than the fundamental operating frequency. If the original time-domain signal is available, statistical correlation techniques can be used to determine if changes are noisy or due to power system fluctuations. If time-domain signals are not available, then random change in both magnitude and angle is used as a heuristic for something happening in the original time-domain signal. The digitals from both the magnitude and angle of a phase-to-phase signal are ANDed together for more confidence in the failure detection.

A failed phase can be identified from the phase-to-phase digitals. If digitals for both the A–B and B–C phases are high, then the logic deduces that the B-phase is faulty. If digitals for

both the B–C and C–A phases are high, then the logic deduces that the C-phase is faulty. Similarly, the A-phase is faulty when the digitals for both the A–B and C–A phases are high. This results in the detection signals  $D_A$ ,  $D_B$ , and  $D_C$  (see Fig. 2) for A-, B-, and C-phase VT circuit failures, respectively.

#### D. Postprocessing

PMUs typically report phasor estimates at 25, 30, 50, or 60 samples/second. The detection algorithm discussed in the previous section operates at the native sampling rate. Because the failure signatures are intermittent and can last for weeks, alarms that are generated at the native PMU data rate can overwhelm operators and engineers. In the postprocessing stage, digital flags are further qualified to avoid false alarms.

Fig. 3 shows the overall flow of the postprocessing stage. First, the digitals from the detection algorithm are cumulated over a time window ( $T$ ). The cumulated values are then passed through a moving average filter (MAF). Using both the cumulation and MAF stages together provides advantages over simply averaging a time window. The cumulation stage can significantly reduce the MAF filter length required for satisfactory operation. For example, if the PMU data rate is 30 samples/second, a moving average over a minute requires an MAF of length 1,800. If  $T$  equals 1 second, then the MAF length can only be 60. This effectively works to downsample the original signal to 1 sample/second.

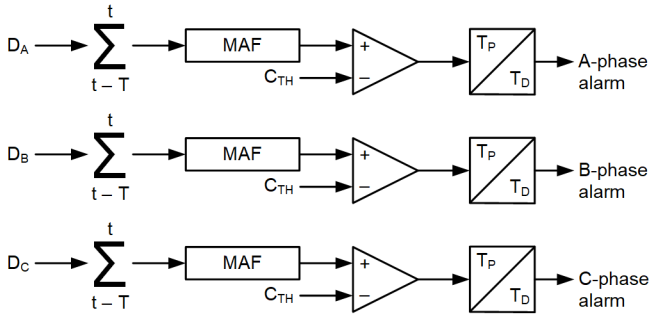

Fig. 3. Postprocessing of VT circuit failure detection digitals.

Alarm generation requires thresholding. For the postprocessing stage, the MAF filter taps can be set so that the output is a detection percentage over all samples in a certain time window (e.g., 1 minute). The alarm pickup time ( $T_P$ ) and the dropout time ( $T_D$ ) can also be used to enhance the alarming process. In addition, time grouping, or hysteresis, can be used to reduce alarms that are due to chattering.

The algorithm is applied to A-, B-, and C-phase voltage magnitudes and angles measured by a relay or digital fault recorder (DFR) at different locations in a power system, allowing for simultaneous monitoring of all (or a subset of all) VT circuits in a power system. The following section presents the monitoring results for two real-world cases of VT fuse failures.

### III. RESULTS

The utility synchrophasor system used as an example in this paper consists of more than 300 PMUs that measure

three-phase voltages and currents. PMUs are deployed at a variety of voltage levels. The utility uses both protective relays and standalone DFRs to provide synchrophasor measurements. The PMUs stream synchrophasor measurements at 30 samples/second to a centralized phasor data concentrator (PDC) via IEEE C37.118 [6]. Synchrophasor data are forwarded to time-series data situational awareness software in the utility’s grid operations. The situational awareness software provides real-time processing, analysis, visualization, and archiving of time-series data for utility operators and engineers.

On multiple occasions, utility engineers noticed anomalous PMU voltage measurements via the situational awareness software. This led the engineers to conclude that VT maintenance was required. Because not all voltage signals can be monitored continuously by operators or engineers, the algorithm described above was subsequently designed to automatically detect these conditions. Two specific cases are discussed next.

#### A. First Detected VT Failure

In May 2021, the utility completed scheduled VT maintenance at a substation that provided power to an industrial load. After VT maintenance, small C-phase voltage drops began to appear in the synchrophasor data. The voltage drops were between one and three percent in magnitude, and seemingly random in nature. After a month, the utility serviced the VT and replaced the C-phase fuse. After the C-phase fuse was replaced, the voltage measurements returned to normal.

In this event, the synchrophasor data successfully provided the utility with information well before failure, allowing for a VT service to be scheduled at a convenient time prior to the pending failure. A one-hour-long record of data for the event is shown in Fig. 4. The VT was serviced around the twentieth hour of the day. As shown, the random voltage drops and phase-angle changes disappeared after the VT was serviced.

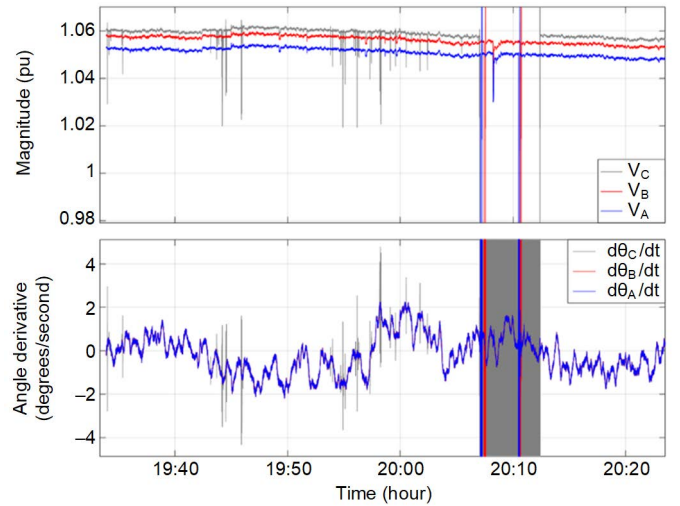

Fig. 4. Random voltage drops and phase-angle changes exist prior to service on a VT that had a failing fuse.

The three-phase voltage magnitudes and angles were preprocessed according to the preprocessing technique described in Section II, Subsection B. For PMU measurements at 30 samples/second, a 5-sample median filter was used.

The incipient failure signatures were detected by the failure detection procedure presented in Section II, Subsection C, with  $V_{TH}$  equaling 0.001 pu and  $\theta'_{TH}$  equaling 0.1 degree/second. An LPF with passband and stopband frequencies of 0.001 and 0.05 Hz, and ripples of 0.02 and 10 dB, respectively, was used as the LPF with IIR. An equiripple LPF with passband and stopband frequencies of 1.5 and 2.5 Hz, and ripples of 0.02 and 50 dB, respectively, was used as the LPF with FIR.

Fig. 5 shows the detection signals  $D_A$ ,  $D_B$ , and  $D_C$  (see Fig. 2 for the process that creates these signals) on top of the voltage magnitude signals. In the figure, a marker is displayed when the corresponding detection signal is high, i.e., when a failure in the corresponding phase is detected. The algorithm successfully detected the failure in the incipient stage for the C-phase and reported that the other two phases were healthy. During the maintenance, the algorithm detected that all phases were faulty as the crew worked on the VT circuit contacts.

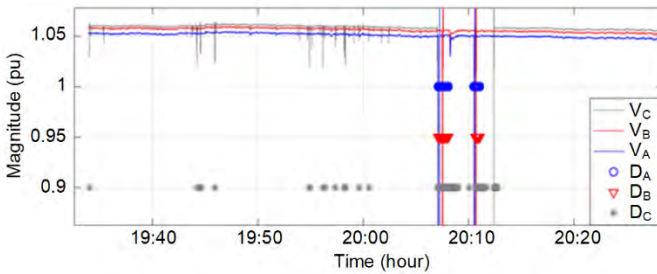

Fig. 5. Incipient failure detection results from the signals shown in Fig. 4. The vertical axis magnitude is for the voltage values  $V_A$ ,  $V_B$ , and  $V_C$ .  $D_A$ ,  $D_B$ , and  $D_C$  are digital signals and are distributed vertically for visual clarity.

The detection signals  $D_A$ ,  $D_B$ , and  $D_C$  were postprocessed using the techniques described in Section II, Subsection D, with  $T$  equal to 1 second. A 60-tap MAF with coefficient values equal to  $100 / (60 \cdot f_s)$  was used, with a sampling rate of  $f_s = 30$  samples/second. The pickup time ( $T_P$ ) and dropout time ( $T_D$ ) were set to 0 seconds and 1 hour, respectively.

Alarms were generated with the threshold ( $C_{TH}$ ) set to 1 percent. With this setting, an alarm is generated when the VT failure is detected 1 percent of the time, averaged over the last 1 minute of synchrophasor data. The alarm setting significantly reduces the number of alarms generated for each event, so that operators are not overwhelmed. For this event, only one alarm was generated (near the time 19:44 in Fig. 6) for the whole duration of the signal. The MAF filter outputs are shown in Fig. 6, along with the  $C_{TH}$  threshold.

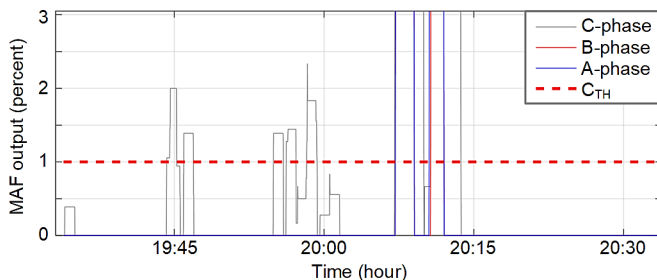

Fig. 6. MAF signal for the VT fuse failure event shown in Fig. 4.

## B. Second Detected VT Failure

The utility experienced another VT circuit failure event in 2021, but at a different voltage level than that of the first case. On the twenty-sixth day of the month, drops in the C-phase voltage at a line terminal began. The synchrophasor data for this event are shown in Fig. 7. The figure shows that the C-phase voltage drops grew in frequency and magnitude over several days. On the first day of the next month, the VT was serviced, and after completion of the service, the C-phase voltage drops continued to grow in severity and frequency. On the third day, the VT C-phase fuse failed, at which point the fuse was replaced, and the voltage measurements returned to normal.

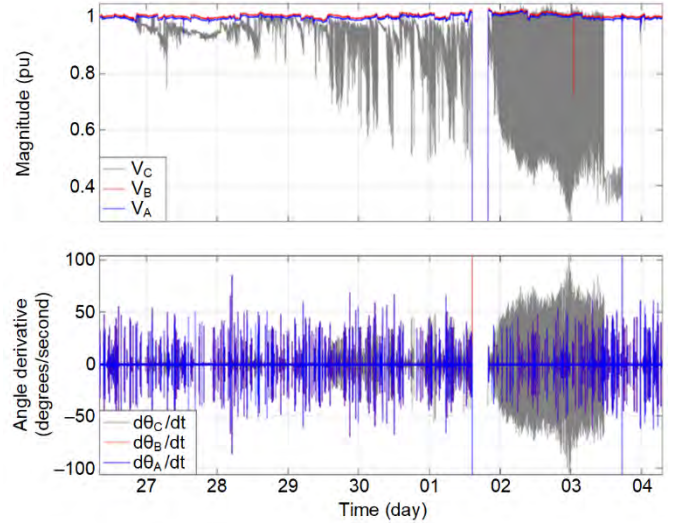

Fig. 7. Phase voltage magnitudes and angles for a C-phase VT fuse failure event in the system.

For this second event, the voltage-drop magnitude was much higher compared to the voltage drops in the first event. The relay LOP logic might have detected this event if the logic was enabled, but information on the LOP logic status was not available. In this event, the synchrophasor data successfully provided the utility with actionable information seven days prior to the C-phase VT fuse failure.

The data were applied to the VT failure detection algorithm with the same parameter and threshold settings and filters as for the first event. Fig. 8 and Fig. 9 show the results from the failure detection and postprocessing subsystems, respectively.

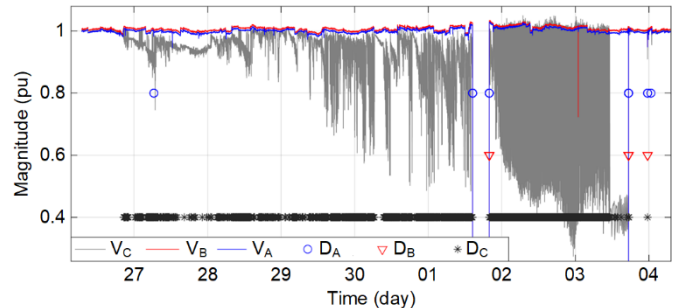

Fig. 8. Incipient failure detection results from signals shown in Fig. 7. The vertical axis magnitude is for the voltage values  $V_A$ ,  $V_B$ , and  $V_C$ .  $D_A$ ,  $D_B$ , and  $D_C$  are digital signals and are distributed vertically for visual clarity.

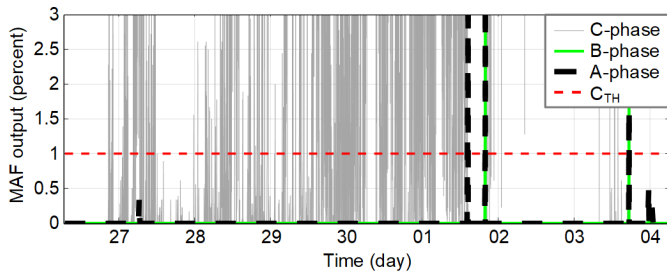

Fig. 9. MAF signal for the VT fuse failure event shown in Fig. 7.

Fig. 9 indicates that the system detected the impending failure on the twenty-sixth day. An early warning like this can allow power system utilities to monitor for VT circuit failures in an incipient stage, and provide utilities with enough time to plan for repairing or replacing faulty components before they lead to significant damage or cause unintentional system outages.

Fig. 8 shows that the failure detection subsystem detected an A-phase failure on the twenty-seventh day for a short instant of time. This was likely a false detection, because the A-phase seemed to be healthy. A false detection like this one does not result in an alarm, because it is smoothed over a certain time interval in the postprocessing stage. In Fig. 9, it is clear that the peak in the A-phase on the twenty-seventh day did not cross the  $C_{TH}$  threshold.

#### IV. CONCLUSION

A novel monitoring algorithm was developed for the automatic monitoring of incipient-stage VT circuit failures, and the algorithm was described in detail in Section II as a part of a complete monitoring system. The system was applied to two real-world VT fuse failure cases observed in a utility's system, and Section III discussed the results in detail. The data show that the system provides early warning of impending failure days, or even weeks, before actual failure. This is useful to power system utilities, because it allows enough time for planning and scheduling a repair before the failure damages system assets or causes a service interruption or outage.

Automatic detection is required for utilities that have hundreds of PMUs measuring synchrophasors from a significant number of VTs. As utilities move forward with smart grid initiatives and install more PMUs in their systems, manual investigation of all measurements for all VTs continuously is not practical. Thus, an automatic detection system that is appropriate for a control room environment, such as the system presented in this paper, can bring a significant benefit to power system utilities by automatically monitoring thousands of voltage measurements constantly and operating their power systems accordingly.

#### V. ACKNOWLEDGMENT

The authors would like to thank Fernando C. Calero, an expert in power system protection and control from Schweitzer Engineering Laboratories, Inc., for his thoughtful feedback on the work presented in this paper.

#### VI. REFERENCES

- [1] S. Gray, D. Haas, and R. McDaniel, "CCVT Failures and Their Effects on Distance Relays," proceedings of the 71st Annual Conference for Protective Relay Engineers (CPRE), College Station, TX, March 2018.
- [2] S. Ahmadi, M. Sanaye-Pasand, and M. Davarpanah, "Preventing Maloperation of Distance Protection due to CCVT Transients," *IET Generation, Transmission & Distribution*, Vol. 13, Issue 13, July 2019, pp. 2828–2835.
- [3] B. Kasztenny and I. Stevens, "Monitoring Ageing CCVTs: Practical Solutions With Modern Relays to Avoid Catastrophic Failures," proceedings of the 32nd Annual Western Protective Relay Conference, Spokane, WA, October 2005.
- [4] J. Roberts and R. Folkers, "Improvements to the Loss-of-Potential (LOP) Function in the SEL-321," SEL Application Guide (AG2000-05), 2000. Available: selinc.com.
- [5] A. Silverstein, "Diagnosing Equipment Health and Mis-operations With PMU Data," *NASPI Technical Report*, North American Synchrophasor Initiative, 2015.
- [6] IEEE Std C37.118.1-2011, *IEEE Standard for Synchrophasor Measurements for Power Systems*.

#### VII. BIOGRAPHIES

**Matthew Rhodes** is a principal electrical engineer at the Salt River Project (SRP), an agency of the state of Arizona that serves as an electrical utility for the Phoenix metropolitan area. Matt joined SRP in 2007, and has a master's degree in electrical engineering from Arizona State University. Matt currently serves as the co-lead for the North American Synchrophasor Initiative (NASPI) engineering analysis task team.

**Md Arif Khan** is a development lead engineer at Schweitzer Engineering Laboratories, Inc. (SEL) and is responsible for research and development of new power system monitoring, operations, and control technologies. He holds a PhD and a Master of Science, both in electrical engineering, from the University of Wyoming. Dr. Khan is a senior member of the IEEE, and a member of the Tau Beta Pi honor society. He was the recipient of a University Gold Medal in 2010 from Khulna University of Engineering and Technology (KUET), Khulna, Bangladesh, and the President's Award in 2014 from the Rocky Mountain Bioengineering Symposium, Denver, Colorado.

**Joshua Wold** is a power engineer at Schweitzer Engineering Laboratories, Inc. (SEL) and works on wide-area power system analysis software. He holds a PhD in electrical engineering from Montana State University and is a member of the IEEE.

**Greg Zweigle** serves as a Schweitzer Engineering Laboratories, Inc. (SEL) fellow engineer and leads a research team developing wide-area power system analysis and control solutions. He holds a PhD in electrical engineering and computer science, a Master of Science degree in (physical) chemistry, and a Master of Science degree in electrical engineering from Washington State University. He also holds a Bachelor of Science degree in physics from Northwest Nazarene University. Greg is a senior member of the IEEE.

**Jared Bestebreuer** is a product manager at Schweitzer Engineering Laboratories, Inc. (SEL) and is responsible for synchrophasor and relay event analysis software products. He has supported the implementation of wide-area monitoring systems around the world. Jared holds a Bachelor of Science degree in electrical engineering from Washington State University. He is also an active member in the North American Synchrophasor Initiative (NASPI) community.