



WAN and LAN Networks Overview



SEL ICON®

The SEL ICON is a WAN multiplexer optimized for industrial and utility applications. By combining TDM and Ethernet transport options with a comprehensive range of data interfaces, the ICON makes it easy to migrate legacy network technologies to a packet-based solution.



SEL-2740S

The SEL-2740S is the industry's first field-hardened software-defined networking (SDN)-enabled switch and improves cybersecurity and Ethernet performance in mission-critical applications.



SEL-2742S **NEW**

The SEL-2742S is a 12-port, DIN-rail mount SDN switch for industrial environments. It combines with SEL-5056 Flow Controller Software to simplify network engineering and improve LAN security.



SEL-3620/3622

The SEL-3620 and SEL-3622 each function as a router, VPN endpoint, and firewall device. They can provide secure and proxy user access for serial- and Ethernet-based IEDs.



SEL-2730M/2730U

The SEL-2730M/2730U let you build reliable, safe Ethernet networks in electrical substations, plants, and other mission-critical sites.



SEL-3610

The SEL-3610 increases the number of serial ports available to communications processors and computers and allows serial products to communicate securely through Ethernet networks.



SEL-2725

The SEL-2725 allows you to easily connect devices to Ethernet networks.



SEL-3025

The SEL-3025 protects serial communications with bump-in-the-wire security and strong, authenticated access controls.

Applications	SELICON®	SEL-3620	SEL-3622	SEL-3610	SEL-2725	SEL-2730M	SEL-2740S	SEL-2742S	SEL-2890
SONET WAN	■								
Ethernet LAN	■	■	■	■	■	■	■	■	■
Precise Time Distribution	■	■	■	■			■	■	
Engineering Access Control		■	■	■			■	■	
Connect Multiple Wired-Ethernet Devices to Network	■				■	■	■	■	
Convert Wired 10/100BASE-T Ethernet to Fiber-Optic 100BASE-FX Ethernet	■	■	■	■	■	■	■	■	
Convert Serial Links to Ethernet Links	■	■	■	■					■

Features

Cryptography (Encryption and Authentication)	■	■	■	■					
User-Based Accounts	■	■	■	■		■	■	■	
Centralized Authentication Via Lightweight Directory Access Protocol (LDAP)	■ ⁸	■	■	■		■	■	■	
Centralized Authentication Via Remote Authentication Dial-In User Service (RADIUS)		■	■	■		■			
Deny-by-Default Firewall		■	■						
Import/Export Configuration Files		■	■	■		■	■	■	
VPN		■	■						
Syslog Logging	■	■	■	■		■	■	■	
Network Management System (NMS) Software	■					■	■	■	
GPS Receiver	■								
Real-Time Latency Monitor	■								
Spanning Tree Protocol (STP)		■	■	■		■ ¹			
VLANs	■	■	■	■		■	■	■	
Ethernet Class of Service	■					■	■	■	

Ethernet Ports, Connector

Quantities

Copper 10BASE-T, RJ45									1
Copper 10/100BASE-T, RJ45	0–16 ²	3	3	3	3–5	0–16 ³	0–20	2–10	
Fiber-Optic 100BASE-FX, LC	4	2	2	2	0–2	0–16 ³	0–20	0–6	
Copper Gigabit Ethernet (GigE), RJ45	4					4	0–4	0–4	
Fiber-Optic GigE, LC	2 ⁶ /4 ⁷					0–4 ⁴	0–4	0–4	
Small Form-Factor Pluggable (SFP) Cages	2–6 ⁵					4 ⁴			

¹SEL-2730M supports STP plus IEEE 802.1D-2004 Rapid Spanning Tree Protocol (RSTP).

²SEL ICON can support up to 16 Ethernet ports using 8-port Ethernet Access Modules or Ethernet Bridging Access Modules.

³SEL-2730M base configuration supports sixteen 10/100BASE-T copper ports, with the option to substitute 100BASE-FX fiber-optic ports in groups of four.

⁴SEL-2730M base configuration includes 4 copper GigE ports and 4 SFP cages for optional fiber-optic GigE ports.

⁵SEL ICON uses SFP cages for SONET and GigE fiber-optic interfaces.

⁶SEL-8021-1 Line Module supports 2 fiber-optic Gigabit interfaces.

⁷SEL-8036-1 Ethernet Bridging Access Module supports 4 fiber-optic 100BASE-FX/Gigabit interfaces.

⁸SEL-5052 Server NMS Software provides LDAP centralized authentication for the ICON.



WAN and LAN Networks Applications

Maintaining critical services between sites

Install the SEL ICON® Integrated Communications Optical Network to maintain critical services between sites by quickly restoring traffic when an infrastructure disruption, like fiber failure, occurs.

You can configure the ICON to operate as a SONET or Ethernet multiplexer to address the following network use cases:

- Segregated operational technology (OT)—SONET transport (shown here)
- Segregated OT—Ethernet transport
- Converged IT/OT—Multiprotocol Label Switching (MPLS) or Carrier Ethernet core network
- Analog leased line service migration

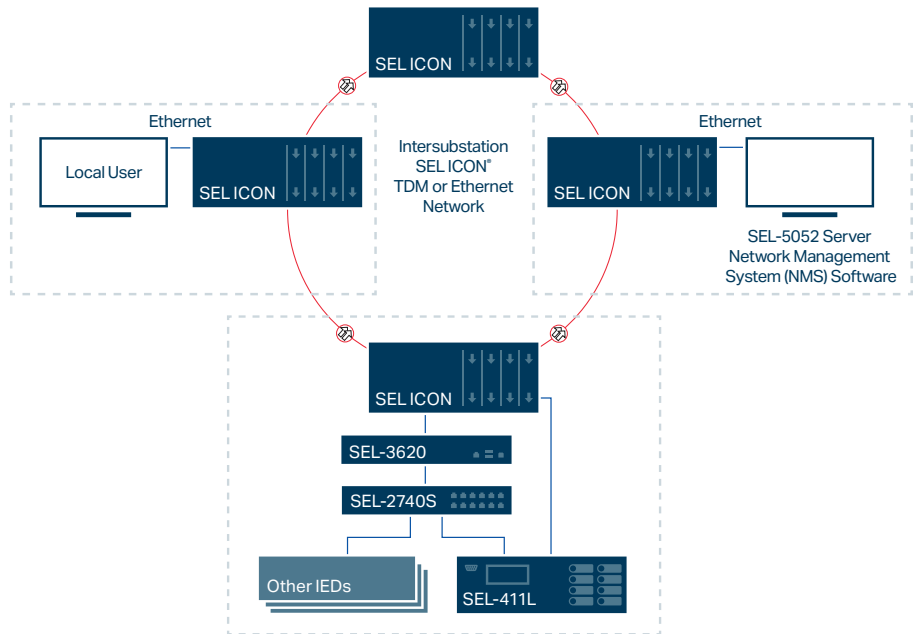

Improving mission-critical Ethernet performance

The breakthrough software-defined networking (SDN) technology in the SEL-2740S Software-Defined Network Switch solves the inherent limitations of Ethernet networks. Every network path is predefined by the user, enabling precise control over how the system responds to network failures. The SEL-2740S fails over in less than 100 μs, ensuring the performance of mission-critical applications under all conditions. This means no more waiting for discovery or convergence times.

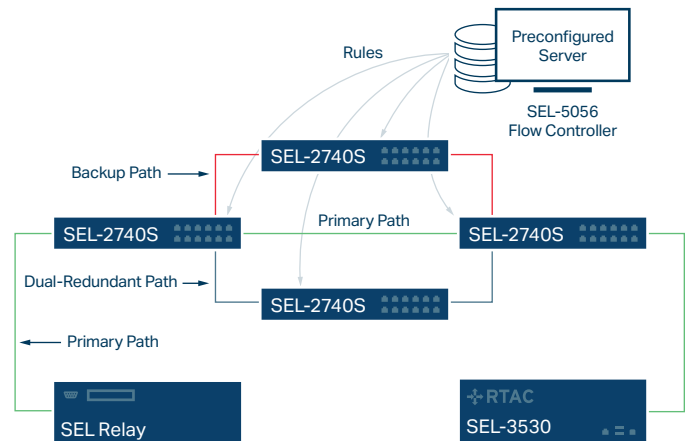

Redefining security for Ethernet networks

The deny-by-default architecture of the SEL-2740S Software-Defined Network Switch means only preapproved traffic that matches specific rules is allowed onto the network. The switch inspects multiple layers of every packet to see if they match the set of rules you define. If there is a mismatch, the SEL-2740S can immediately drop the packet or forward it to an intrusion detection system for in-depth analysis. In addition, you can change these rules at any time.

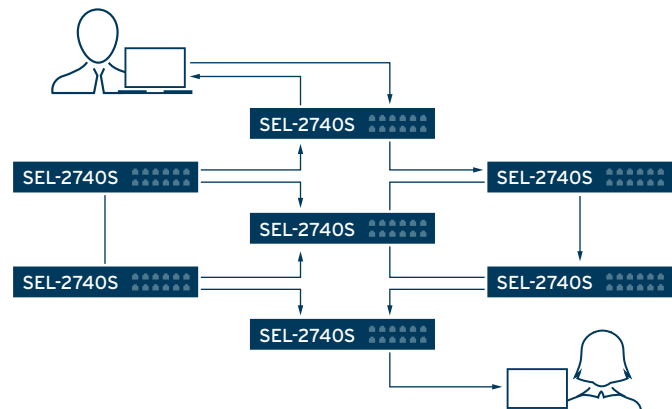

Managing and securing system communications

Install the SEL-3620 Ethernet Security Gateway to secure your control system communications with a stateful deny-by-default firewall, strong cryptographic protocols, and logs for system awareness. The SEL-3620 also manages protected IED passwords and helps create a user audit trail through strong, centralized, user-based authentication and authorization for modern and legacy IEDs.

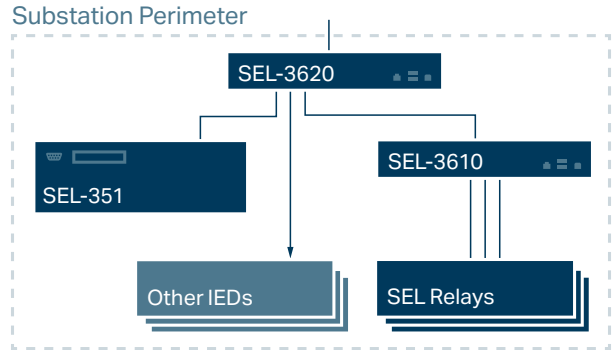

Connecting to SEL products and other devices for secure serial communications

Add 17 serial ports with the SEL-3610 Port Server to connect SEL products and other devices and allow secure serial communications through Ethernet networks. The SEL-3610 tunnels serial data over an Ethernet connection using Secure Shell (SSH), Telnet, Modbus, or raw TCP encapsulation. The SEL-3610 allows you to restrict all access to unconfigured logical and physical ports.

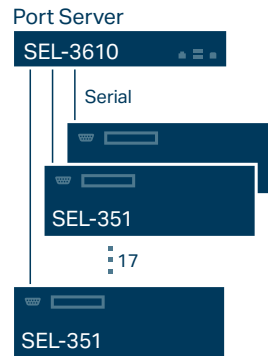

Managing transition from analog to Ethernet leased line services

Apply the bit-based serial conversion technology in the SEL-3620 and SEL-3622 Security Gateways to seamlessly convert existing bit-based serial protocols, such as Conitel, Tejas, Van Comm, and Redaj, to Ethernet packets on the near side of a link. Then, reconvert that Ethernet data back into bit-based form on the remote side. This allows the SEL-3620 and SEL-3622 to serve as drop-in replacements for analog line-to-line modem technology without disrupting existing equipment and with minimal additional latency.

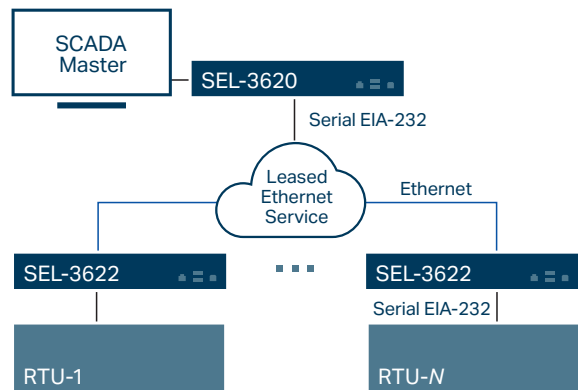

SEL ICON[®]

Integrated Communications Optical Network

selinc.com/products/ICON 

Starting price

Configured ICON Node: \$6,000 USD

SEL-5051 Client Network Management System (NMS) Software: \$5,180 USD

SEL-5052 Server NMS Software: \$5,180 USD

The SEL ICON is a WAN multiplexer optimized for industrial and utility applications. You can configure the ICON to operate as a SONET or Ethernet multiplexer to address the following network usage cases:

- Segregated operational technology (OT)—SONET transport
- Segregated OT—Ethernet transport
- Converged IT/OT
- Analog leased line service migration

The virtual synchronous networking (VSN) technology in the ICON preserves the performance characteristics of time-division multiplexing (TDM) when converting to Ethernet as a transport protocol. By combining TDM and Ethernet transport

options with a comprehensive range of data interfaces, the ICON makes it easy to migrate legacy network technologies to a converged IT/OT packet-based solution. The ICON interoperates with Multiprotocol Label Switching (MPLS) or Carrier Ethernet core networks to provide a hardened OT edge multiplexer for mission-critical applications.

SEL-5051 Client and SEL-5052 Server NMS Software help you maintain a secure, reliable, and efficient communications infrastructure. In the client-server architecture, the SEL-5051 Client Software connects to the SEL-5052 Server Software to provide an efficient solution for managing network access for multiple users. The SEL-5052 Server Software offers centralized user security, settings, alarms, and event management.



- 1 Protected Line Modules
- 2 Server Module
- 3 Ethernet Bridging Access Module
- 4 IEEE 1613-compliant packaging
- 5 Seven slots for access modules (Ethernet Bridging Access, Quattro, and Transfer Trip Modules shown)
- 6 Dual redundant power supplies
- 7 The ICON is available in a standard 19" rack-mount chassis or in a compact ICON Cube package for limited-space applications.
- 8 Protected Line Modules
- 9 Server Module
- 10 Two slots for access modules (Ethernet Access and Quattro Modules shown)
- 11 Dual redundant power supplies

ICON Modules

Part Number	Description	Starting Price
Power Modules		
8011-02	19-Inch Rack Power Module, High-Voltage AC/DC, 120–240 V, 92 W	\$420
8010-02	8-Inch Cube Power Module, High-Voltage AC/DC, 120–240 V, 63 W	\$370
Control Modules		
8020-01	Line Module	\$2,110
8021-01	Protected Line Module	\$1,560
Server Module		
8030-01	Server Module	\$630
Access Modules		
8035-01	Ethernet Access Module	\$730
8036-01	Ethernet Bridging Access Module	\$1,040
8036-02	Ethernet Bridging Access Module With Precision Time Protocol (PTP)	\$1,550
8041-01	Transfer Trip 4-Function 24/48 VDC TX/RX Teleprotection Module	\$1,250
8041-04	Transfer Trip 4-Function 125/250 VDC TX/RX Teleprotection Module	\$1,250
8050-01	Quattro Module (accepts 2 DS1 or 4 non-DS1 submodules)	\$230
8051-01	Nx64F IEEE C37.94 Multimode Quattro Submodule	\$230
8051-02	Nx64F IEEE C37.94 Single-Mode Quattro Submodule	\$500
8053-01	Async Data Quattro Submodule	\$220
8055-01	422 Sync Quattro Submodule	\$390
8056-01	G.703 Quattro Submodule	\$390
8057-01	DS1 Async (Quad DS1 Ports) Quattro Submodule	\$470
8057-02	DS1 Sync (Quad DS1 Ports) Quattro Submodule	\$830
8057-03	DS1 Psync (Quad DS1 Ports) Quattro Submodule	\$830
8065-01	4-Wire VF Dual Ports Quattro Submodule	\$340
8065-02	Single-Port (Dual Connectors) 4-Wire Bridging VF Submodule	\$510
8066-01	FXS Single-Port Quattro Submodule	\$340
8067-01	FXO Dual-Port Quattro Submodule	\$340

SEL-2740S/2742S

Software-Defined Network Switches **NEW**

Starting price
SEL-2740S: \$3,885 USD
SEL-2742S: \$2,200 USD

selinc.com/products/2740S or selinc.com/products/2742S 

Select models typically ship in 2 days 

The SEL-2740S and SEL-2742S are the industry's first software-defined networking (SDN) switches designed for operational technology (OT) networks. The SEL SDN solution includes SEL-2740S and SEL-2742S switches, the SEL-5056 Software-Defined Network Flow Controller, and the SEL-5057 SDN Application Suite. These products work together to create a more secure OT LAN with 100 times faster failover times and greater situational awareness.

SEL SDN uses a deny-by-default architecture where the SEL-2740S and SEL-2742S switches will only forward authorized traffic. The switches use multilayer packet inspection to ensure that each packet meets predefined criteria. SEL SDN also improves security by eliminating two attack-prone elements of traditional Ethernet switches—the Rapid Spanning Tree Protocol (RSTP) and MAC tables.

SEL SDN offers important benefits for IEC 61850 systems. Because failover paths are predefined, network healing times are reduced from tens of milliseconds to under 100 microseconds. Also, SEL SDN provides greater control over multicast traffic for IEC 61850 GOOSE or Sampled Values (SV).

The SEL-2740S and SEL-2742S can act as transparent Precision Time Protocol (PTP) clocks, supporting the IEEE C37.238 power system profile to ensure submicrosecond time synchronization of end devices. The SEL-2740S, SEL-2742S, and SEL-5056 support Syslog for secure log management.

The SEL-2740S is a 20-port switch designed for use in a 19" rack in utility substations. The SEL-2742S is a DIN-rail-mounted 12-port switch with Power over Ethernet Plus (PoE+) for industrial environments. Both switches can be powered from two sources, and the SEL-2740S offers dual hot-swappable power supplies.

Both switches withstand harsh environments commonly found in the utility and industrial sectors and operate reliably from -40° to $+85^{\circ}\text{C}$ (-40° to $+185^{\circ}\text{F}$). They meet IEEE 1613 and IEC 61850-3 standards.

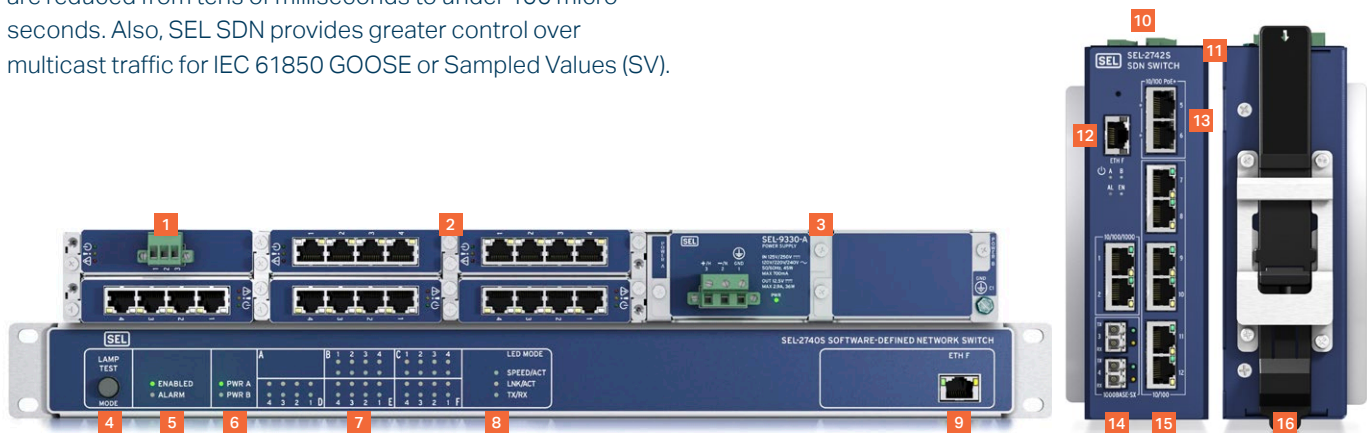

- 1 Flow processor and alarm contact.
- 2 Five modular slots for copper or fiber Ethernet interface options (in sets of four).
- 3 Dual power supply options for hot-swappable redundancy.
- 4 Lamp Test button verifies all LEDs are functional and lets you select the LED mode.
- 5 General status indicators.
- 6 Power supply status LEDs.
- 7 Ethernet port status LEDs.
- 8 Three LED modes are available for the Ethernet port status.
- 9 Out-of-band flow controller port.
- 10 Dual power supply connections.
- 11 Rugged chassis operates in -40 to 85°C (-40° to $+185^{\circ}\text{F}$).
- 12 Ethernet management port.
- 13 Two 10/100BASE-T PoE+ ports.
- 14 Four 1 Gbps ports—copper, single-mode fiber, or multimode fiber.
- 15 Six 10/100BASE-T ports—copper or multimode fiber.
- 16 Top hat DIN clip.

SEL-5056

Software-Defined Network Flow Controller

Included With SEL Software-Defined Network Switches

selinc.com/products/5056 

The SEL-5056 flow controller is the central interface for the commissioning, configuration, and monitoring of SEL software-defined networking (SDN) switches. The only changes allowed on the network are made through the flow controller. With SEL SDN, you'll have advanced situational awareness. You'll know exactly what devices are on your network and all the conversations each device is having. No additional engineering access interface is necessary on SEL-2740S or SEL-2742S Software-Defined Network Switches.

The SEL-5056 is a server-based software tool. This flow controller configures primary and backup paths for each communications flow on SEL-2740S and SEL-2742S switches by using attributes of a specific protocol session and forwarding paths instead of requiring MAC addresses and VLANs. The SEL-5056 provides comprehensive monitoring of all path- and packet-level network statistics of each communications flow, increasing awareness of the network health and status. In addition, you can programmatically test the network implementation before deployment.

SEL-5056 network configuration can be performed in the field with all IEDs connected or can be performed offline in a lab. Offline configuration provides flexibility and can reduce the downtime required for field installations.

HTTPS provides encryption and authentication for secure management of SEL-5056 web browser communication. SEL-5056 communication to all SEL-2740S and 2742S

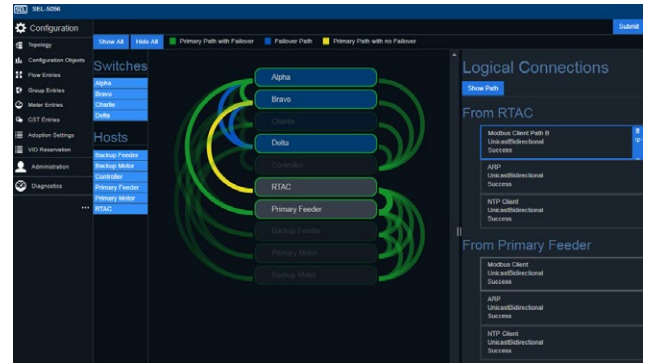

switches occurs through encrypted and authenticated Transport Layer Security (TLS). Keys are securely managed through X.509 certificates. You can configure user accounts on the SEL-5056 or use the Lightweight Directory Access Protocol (LDAP) to authenticate users. The SEL-5056, SEL-2740S, and SEL-2742S support Syslog for secure log management. In addition, the flow controller provides backup and restore features for maintaining high reliability.

Learn & Lock is an extension for the SEL-5056 that provides supervised automation for commissioning SDN switches, learning what conversations are trying to happen, and provisioning circuits to allow those conversations. Learn & Lock streamlines configuration by discovering devices on the LAN and creating a set of flows for the current traffic.

SEL-5057

SDN Application Suite **NEW**

Starting price
\$1,850 USD

selinc.com/products/5057 

The SEL-5057 SDN Application Suite is a collection of software applications that integrate with the SEL-5056 Software-Defined Network Flow Controller to add capabilities to SEL software-defined networking (SDN) solutions. Flow Auditor is the first SEL SDN application in the suite.

Flow Auditor

Streamline data collection for NERC CIP reporting

Use the SEL Flow Auditor application to streamline data collection for NERC CIP-007-6 R1 audit reporting. It collects information on what ports and services are running on the network from the SEL-5056 without the need for network scanning. With Flow Auditor, data collection takes minutes instead of days or weeks.

Capabilities

Identifying Devices in Your Network—Automate the discovery and documentation of all devices on the LAN.

Documenting Ports and Services—Perform data collection and generate audit reports for NERC CIP-007-6 R1. Flow Auditor does not require network scanning, logging into IEDs, or even logging into the SEL-5056.

Maintaining Security—Use Open Authentication (OAuth) for mutual authentication and encryption between Flow Auditor and the SEL-5056.

SEL-5057 SDN Application Suite

Software-Defined Networking
(SDN) Architecture Layers

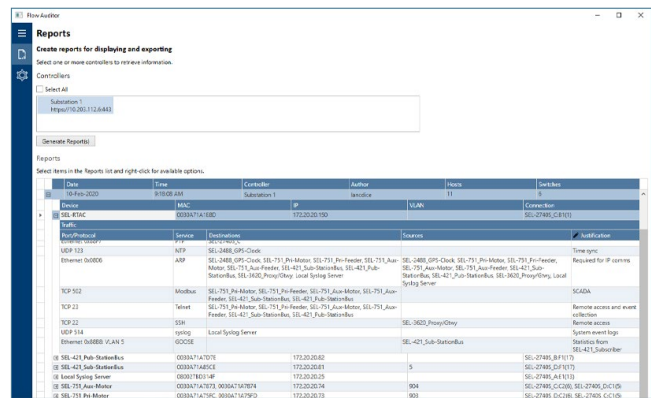
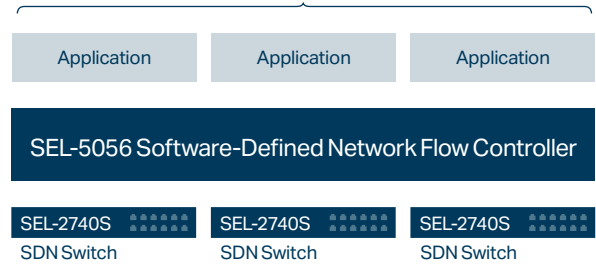

SEL-3620/3622

Ethernet Security Gateway/Security Gateway

Starting price
SEL-3620: \$2,900 USD
SEL-3622: \$830 USD

selinc.com/products/3620 or selinc.com/products/3622 

Select models typically ship in 2 days 

The SEL-3620 and SEL-3622 each act as a router, VPN endpoint, and firewall device and can perform secure and proxy user access for serial- and Ethernet-based IEDs. They help create a user audit trail through strong, centralized, user-based authentication and authorization for modern and legacy IEDs. Each security gateway secures your control system communications with a stateful deny-by-default firewall, strong cryptographic protocols, and logs for system awareness. They also manage protected IED passwords, ensuring that passwords are changed regularly and conform to complexity rules. Device checkout and common, persistent passwords improve IED access.

For enhanced security, the SEL-3620 and SEL-3622 help you protect critical cyber assets by employing strong multifactor authentication technologies, such as RSA SecurID, that use the Remote Authentication Dial-In User Service (RADIUS). The SEL security gateways resist known and unknown malware attacks with exe-GUARD® embedded antivirus technology. Powerful rootkit resistance, embedded Linux mandatory access controls, and process whitelisting help mitigate attacks against the gateways and eliminate costly patch management and antivirus signature updates.

The SEL-3620 and SEL-3622 support NERC CIP compliance efforts without needing Technical Feasibility Exceptions (TFEs). They also support the SEL-5827 Virtual Connect Client and SEL-5828 Virtual Port Service Software. These free software applications make remote gateway ports available for existing software and terminal applications on your PC, including those using Modbus TCP/RTU.

The SEL-3620 has 16 serial ports with 5 V power on Pin 1 and comes in a rack-mount form factor. The SEL-3622 has 4 serial ports in a small form factor that is ideal for mounting in cabinets. It detects physical tampering with an onboard accelerometer, light sensor, and input contact sensor and alerts operators when Ethernet cables are connected or disconnected.

SEL designed and built the SEL-3620 and SEL-3622 in cooperation with the U.S. Department of Energy National SCADA Test Bed and the following companies:

- EnerNex Corporation
- Tennessee Valley Authority
- Sandia National Laboratories

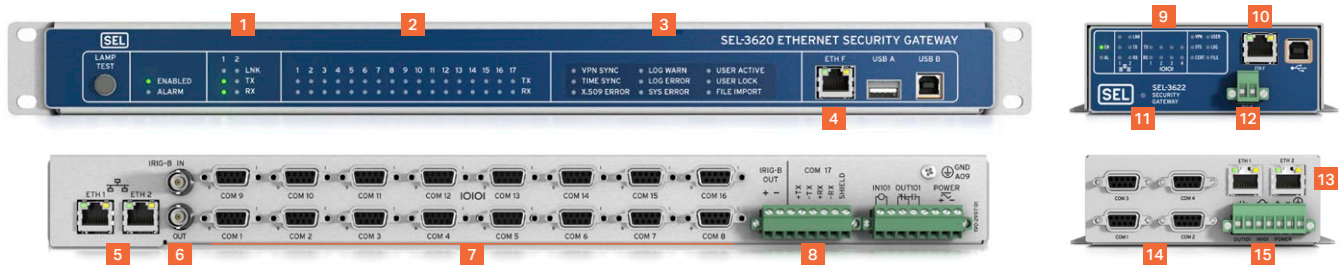

- | | |
|---|---|
| <ul style="list-style-type: none"> 1 Ethernet link status LEDs 2 Serial RX/TX LEDs 3 System status indication LEDs 4 Front Ethernet port 5 Rear Ethernet ports 6 IRIG-B input/output BNC ports 7 16 DB-9 EIA-232/-422/-485 software-selectable serial ports with IRIG-B and 5 V power on Pin 1 8 Isolated COM Port 17 | <ul style="list-style-type: none"> 9 Status LEDs 10 Front Ethernet port 11 Light sensor 12 IRIG-B input 13 Rear Ethernet ports 14 Software-selectable serial ports with IRIG-B 15 Cabinet door contact sensor input |
|---|---|

SEL-2730M/2730U

24-Port Ethernet Switches

Starting price
SEL-2730M: \$1,920 USD
SEL-2730U: \$1,560 USD

selinc.com/products/2730M or selinc.com/products/2730U 

Select models typically ship in 2 days 

The SEL-2730M Managed 24-Port Ethernet Switch and SEL-2730U Unmanaged 24-Port Ethernet Switch support communications infrastructure for engineering access, SCADA, and real-time data communications while offering the same reliability found in SEL protective relays. Both switches are designed for the harsh conditions found in energy and industrial environments and meet or exceed the IEEE 1613 (Class 1), IEC 61850-3, and IEC 60255 industry standards for vibration, electrical surges, fast transients, extreme temperatures, and electrostatic discharge for communications devices in electrical substations.

The SEL-2730M is easy to use and administer, with a web management interface and advanced configuration options to meet your needs. The SEL-2730U is an unmanaged “no settings” switch with ports that automatically configure for crossover cables, speed, and half- or full-duplex operation.



SEL-3025

Serial Shield®

selinc.com/products/3025 

Starting price
SEL-3025: \$940 USD
PC Serial Security Kit: \$420 USD
SEL-3045 Secure SCADA Card: \$260 USD
(included in kit)

The SEL-3025 uses powerful AES 128-/256-bit and SHA-1-/256 key strengths to encrypt and authenticate serial and dial-up links at speeds up to 57,600 bps. The cryptographic module provides confidentiality and integrity for remote monitoring and interactive remote access while locking out hackers and other malicious intruders. With its remote management functionality and wide range of application support, the SEL-3025 is flexible and easy to use.

You can use the SEL-3025 with the PC Serial Security Kit to transform normal serial PC communications to cryptographically secure serial PC communications. Simply plug in the USB card dock and install the virtual port software to use a secured serial port with existing software and terminal applications.



SEL-3610

Port Server

Starting price
\$1,870 USD

selinc.com/products/3610 

 Select models typically ship in 2 days

The SEL-3610 is an EIA-232, EIA-422, or EIA-485 serial-to-serial and Ethernet-to-serial cryptographic port server. It increases the number of available serial ports for communications processors and computers and allows serial products to communicate securely through Ethernet networks. The SEL-3610 tunnels serial data over an Ethernet connection using Secure Shell (SSH), Telnet, Modbus, or raw TCP or UDP encapsulation. The SEL-3610 provides highly flexible byte- or bit-based serial and Ethernet port mappings and can filter data based on which connections listen or transmit. You can configure the device to establish virtual bonds between one or more logical Ethernet ports and one or more physical serial ports. The SEL-3610 supports enhanced security, including user authentication through the Lightweight Directory Access Protocol (LDAP). It also supports multifactor authentication technologies, such as RSA SecurID, that use the Remote Authentication Dial-In User Service (RADIUS).



SEL-2725

Five-Port Ethernet Switch

Starting price
\$470 USD

selinc.com/products/2725 

 Select models typically ship in 2 days

The SEL-2725 is an unmanaged five-port switch and copper-to-fiber-optic media converter. With the SEL-2725, you can build reliable, safe Ethernet networks in electrical substations, plants, and other mission-critical sites. The SEL-2725 can connect to devices in the same cabinet using shielded twisted-pair Category 5 cable and communicate with the substation or LAN over a fiber-optic link. Mode conversions provide several key network benefits, including regenerating optical signals and extending transmission distances. You can increase the productive life of your existing cabling and active equipment without costly, across-the-board upgrades.



Port Options

Copper		Fiber
3	and	2 multimode
3	and	2 single-mode
4	and	1 multimode
4	and	1 single-mode