

Addressing Analog Leased Line Obsolescence by Preserving Protection Channel Performance Over Ethernet

Jonathan Geurink
Consumers Energy

Kenneth Fodero and Paul Robertson
Schweitzer Engineering Laboratories, Inc.

Presented at the
55th Annual Minnesota Power Systems Conference
Saint Paul, Minnesota
November 12–14, 2019

Previously presented at the
72nd Annual Conference for Protective Relay Engineers, March 2019,
IEEE ROC&C 2018/2019, March 2019, and
Power and Energy Automation Conference, March 2019

Originally presented at the
45th Annual Western Protective Relay Conference, October 2018

Addressing Analog Leased Line Obsolescence by Preserving Protection Channel Performance Over Ethernet

Jonathan Geurink, *Consumers Energy*

Kenneth Fodero and Paul Robertson, *Schweitzer Engineering Laboratories, Inc.*

Abstract—Many power utilities cannot afford to provide private fiber or wireless-based communications to every substation or remote facility. To support communications-assisted protection schemes at sites without private networks, these utilities historically leased analog communications circuits from carrier phone companies.

Thousands of substation sites across North America rely on the predictable and guaranteed performance of analog leased phone lines to run critical power protection circuits. However, national carriers plan to discontinue support for analog-based circuits over the next few years to encourage the migration of power protection services to digital Ethernet-based circuits.

At this time, DS1 pseudowire technology is the standard telecommunications solution for converting analog circuits to packet-based services. This presents a challenge for many utilities. Without a change in approach, power utilities face significant end equipment upgrade costs, and protection performance will be compromised for circuits that currently rely on analog leased lines.

This paper presents a new solution to the migration challenge that enables a utility to preserve existing analog end equipment, create a low-latency circuit through a leased Ethernet service, and maintain end-to-end communications-channel performance for critical applications such as teleprotection. This solution is based on a technology called virtual synchronous network (VSN). VSN technology was originally developed to preserve the performance of time-division multiplexing (TDM) when transporting teleprotection circuits across private core networks based on either Multiprotocol Label Switching (MPLS) or Carrier Ethernet.

This paper also summarizes an extended field trial created by the utility Consumers Energy and analyzes the end-to-end latency performance of a direct transfer trip (DTT) scheme over a leased Ethernet service. The results show that a VSN can be used to improve the latency performance of a leased Ethernet circuit and provide an economical migration path from analog to Ethernet, avoiding the need to upgrade a utility's end equipment.

I. INTRODUCTION

Consumers Energy is an electric and natural gas utility originally founded in 1886 as a streetlight venture in Jackson, Michigan. It now serves 6.7 million of Michigan's 10 million residents and operates in all 68 counties of Michigan's lower peninsula. The utility's combined electric services include generation, transmission, and distribution systems.

Like many utilities, Consumers Energy relies on a combination of private fiber-based network infrastructure (owned by Consumers Energy) and leased communications

services (owned by a telecommunications carrier) to provide communications links to its generation and substation facilities. Because it is not always cost-effective or practical to run private fiber to each site operated by the utility, leasing a communications circuit from a local telecommunications carrier allows Consumers Energy to operate communications-assisted protection schemes and maintain the safety and reliability of its power network.

Consumers Energy has used analog leased lines for critical teleprotection circuits at sites without private fiber connectivity. An analog leased line provides a dedicated point-to-point circuit with low and deterministic latency that makes it ideal for teleprotection traffic.

Consumers Energy, along with a significant number of other utilities across North America, faces a challenge: national telecommunications carriers are ending support for analog leased services and migrating analog users to Ethernet-based circuits. The migration of a circuit from analog to Ethernet can be difficult. Not only does the physical interface connection change, but the circuit's latency and service performance is degraded by interface converters. This change in performance makes it very hard to reliably run a teleprotection channel over that circuit.

National telecommunications carriers have been dramatically increasing the price of analog leased services to motivate utilities to abandon analog and migrate to Ethernet. But the carriers have failed to understand that utilities face a performance tradeoff and a lack of available solutions associated with migration. The reality for most utilities is that they cannot run teleprotection circuits over a typical digital replacement circuit such as Ethernet and keep the same operational reliability of power protection systems that they have with analog leased lines.

This paper presents a solution based on a technology called virtual synchronous network (VSN) and describes how Consumers Energy validated this solution across a live leased Ethernet circuit. The paper also explains applications for which Consumers Energy relies on analog circuits and the steps the utility has taken to implement and validate VSN technology as a migration solution. Finally, this paper shows the performance test results for the extended field trials and concludes with a perspective on what the solution offers to the utility industry as a whole.

II. WHY CONSUMERS ENERGY USES LEASED COMMUNICATIONS CIRCUITS

Consumers Energy relies on communications-assisted schemes to protect its power network. The decision between a leased service and private network communications is driven by the cost and availability of the options at the time of installation.

In the past, leasing a service was a lower-cost option for Consumers Energy compared to purchasing, installing, and maintaining power line carrier (PLC) equipment or fiber-based networks. PLC equipment has fewer proven 46 kV solutions readily available, and 46 kV is a typical subtransmission voltage used by Consumers Energy. Costs for installing and maintaining private fiber can also be high, because the Consumers Energy service territory is relatively large and the distances involved can be significant.

In addition, Consumers Energy interconnects with many cogeneration plants (either on its distribution network or off on spurs) that are not located directly within a zone of protection. However, it is essential to be able to trip a cogeneration plant quickly in the event of a fault. A quick trip prevents an uncontrolled generator from driving current into a faulted circuit or islanding with a load. Because installing private communications circuits for the plants is generally too costly for both the utility and the cogeneration, the only means to reliably communicate with a cogeneration plant within the required timeline is over a leased circuit connection.

III. CONSUMERS ENERGY APPLICATIONS THAT RELY ON ANALOG LEASED LINES

Consumers Energy uses an analog leased service for two primary applications that require IEEE 487 service performance objective (SPO) Class A communications circuit performance. The SPO Class A definition of uninterruptible service performance states that the communications channel must be available before, during, and after a power fault. It also specifies that the channel must have the highest priority for availability and restoration [1].

The first of the two applications that require SPO Class A performance is cogeneration anti-islanding using direct transfer trip (DTT). The generator needs to come offline rather than risk islanding with a load. Because the generator will be forced to trip if the communications channel is lost for more than 1 second (in new installations using substandard communications channels), a highly reliable communications channel of comparable class is typically required.

The second Consumers Energy application that requires SPO Class A performance is system coordination using permissive overreaching transfer trip (POTT) or line current differential. This is used in locations where long lines connect to short lines, where large sources interconnect with small sources, or generally where traditional coordination cannot be

achieved and still meet the clearing criteria. Consumers Energy does not rely exclusively on pilot schemes like POTT as its only method of protection, but it does rely on them for coordination in these situations. Therefore, having dependable communications is crucial.

Consumers Energy leases about 35 analog circuits. The integrated protection devices use copper four-wire circuits for communications. Consumers Energy uses two models of digital current differential relay for line current differential applications and uses a combination of protective relays and devices with frequency-shift audio tones for DTT and POTT applications. All of the devices are obsolete and no longer available from the manufacturers.

One example of a Consumers Energy circuit that relies on leased analog service is shown in Fig. 1. The contact transfer latency performance over this typical DTT circuit is 13.1 ms. The upper-limit acceptable latency for a contact transfer is 32 ms.

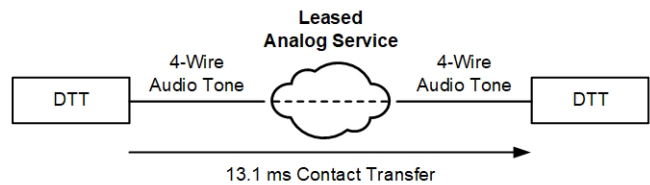

Fig. 1. DTT Over Analog Leased Circuit

IV. INDUSTRY PUSH TO RETIRE ANALOG SERVICES

National telecommunications carriers in the United States have announced plans to retire analog services. The infrastructure carrying analog traffic is aging, and the availability of protection communications devices that work with analog circuits is decreasing.

Most manufacturers have stopped producing analog equipment. For existing equipment installations, manufacturer support and parts availability are becoming increasingly limited. This is driving up maintenance and support costs.

In addition, the rise in cell phone popularity and Internet access has been met by a corresponding decline in the popularity of traditional landline phones. Only a small number of analog users remain.

To grow revenue and remain profitable, telecommunications service providers are focusing on end users looking for higher-bandwidth data services. Because of declining revenues and increased costs for analog-based services, carriers want to focus their resources on Ethernet-based services.

To motivate analog users to migrate to Ethernet and offset the costs of maintaining these aging analog circuits, carriers have been increasing lease costs. Fig. 2 shows how the average monthly cost of an analog service has increased over the past 15 years. As a result, Consumers Energy is no longer able to lease new analog installations in its service territory.

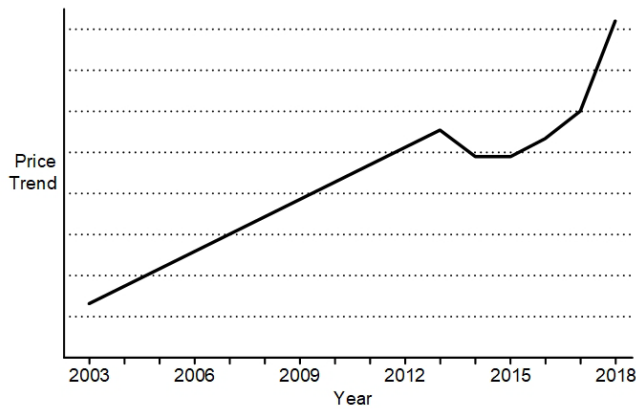

Fig. 2. Average Cost of Analog Leased Circuit Over Time

V. MEETING PROTECTION REQUIREMENTS WITH TELECOMMUNICATIONS TECHNOLOGY

Consumers Energy must find a cost-effective way to migrate to a leased Ethernet service that guarantees the same latency and reliability performance of analog. The service must preserve the same interface to the end devices and employ a solution that meshes well with new fiber standards set by the utility. Consumers Energy will not accept a degradation in circuit performance that reduces the reliability of its power network. Regardless of the evolution in communications technology, the fundamentals of power system protection have not changed. The goal is to move a single data point from one substation to another as close to light speed as possible with very high reliability.

The following summarizes the Consumers Energy performance and service expectations for a leased circuit. These requirements are currently met by analog circuits and need to be met or exceeded by an Ethernet solution.

- Point-to-point connectivity.
- IEEE 487 SPO Class A circuit uninterruptable service performance.
- Support for existing substation equipment.
- Match for existing DTT latency performance of 13.1 ms (32 ms is the absolute maximum to meet the Consumers Energy internal standard).
- High reliability with no misoperations because of channel delays or interference.

VI. CARRIER LEASED ETHERNET SERVICE

Consumers Energy worked with a local telecommunications carrier to understand the migration options and associated costs. Carrier Ethernet service with a real-time service level agreement (SLA) offered the closest fit for comparable performance and cost to existing analog circuits. The telecommunications carrier has Ethernet service available at

75 percent of the locations where Consumers Energy currently leases analog circuits. The Ethernet offering service level is guaranteed with the following specifications:

- 5 ms latency.
- 3 ms jitter.
- 99.995 percent packet delivery rate.
- 99.99 percent net availability.
- Same critical level of restoration as Enhanced 911 and military circuits.

The leased Ethernet service uses fiber optics run to the sites, which eliminates the electromagnetic interference and step potential concerns of traditional copper-based circuits. It costs about \$1,600 a month to lease a 100 Mbps Ethernet circuit with two connections, which is similar to the cost of leasing a single analog circuit in 2018. The costs are lower for leasing bandwidth below 100 Mbps. A target bandwidth for a Consumers Energy leased Ethernet circuit is 10 Mbps, which provides sufficient protection capability at a lower cost.

VII. CONSUMERS ENERGY SUBSTATION EQUIPMENT REQUIREMENTS

For Ethernet to be a viable solution, the equipment needs to operate within a substation environment and meet the Consumers Energy substation product requirements, including:

- Meeting the IEEE 1613 standard for network devices.
- Supporting 48 or 125 Vdc.
- Supporting existing relay protection schemes.
- Being cost-effective.
- Being easy to use and maintain.
- Having excellent manufacturer support.
- Using industry-standard interfaces.
- Supporting the latest Consumers Energy protection standards.

The latest Consumers Energy fiber-based protection standards are shown in Fig. 3 for DTT schemes, in Fig. 4 for line current differential schemes, and in Fig. 5 for POTT schemes.

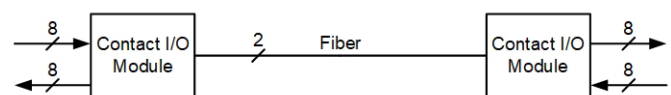

Fig. 3. Consumers Energy DTT Protection Standard

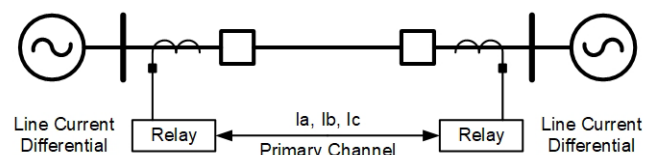

Fig. 4. Consumers Energy Line Current Differential Protection Standard

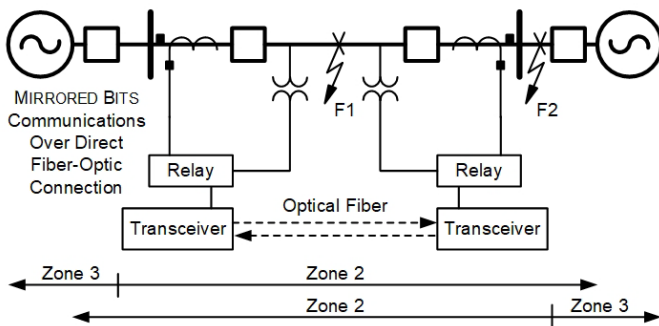

Fig. 5. Consumers Energy POTT Protection Standard

VIII. SOLVING THE PROBLEM OF DTT CONTACT TRANSFER

Consumers Energy began by evaluating a solution for DTT contact transfer. The utility uses analog leased lines for this scheme most often. This solution would also include the old relay equipment discussed in Section III.

With the intention of using the existing, familiar devices from its new fiber-based protection standards, Consumers Energy investigated serial-to-Ethernet transceiver solutions. The utility also considered direct Ethernet relay input/output (I/O) products. Multiple solutions from various manufacturers were evaluated, including industrial-rated devices. Consumers Energy quickly ruled out the majority of the industrial solutions because of their inability to meet core requirements. Problems with the industrial solutions included:

- Insufficient contact and power voltage ratings (support for 125 Vdc is not common).
- Undesired requirements for auxiliary relays, additional power supplies, and external wiring.
- Best-effort latencies and packet delivery (which can result in unreliable protection).
- Questionable tolerance to heat, cold, and power surges.

The topologies used to test the serial-to-Ethernet transceiver approaches are shown in Fig. 6. The contact I/O modules use MIRRORED BITS communications as the serial communications protocol and require deterministic, low-latency channels to maintain synchronization. These approaches did not work. The transceivers established the link initially but quickly went into alarm after losing synchronization. Standard transceivers were unable to maintain a synchronized deterministic path.

Ultimately, the solution to the problem of synchronization in serial-to-Ethernet MIRRORED BITS communications was finally found in an approach originally designed for another purpose. This approach helps run real-time, deterministic time-division

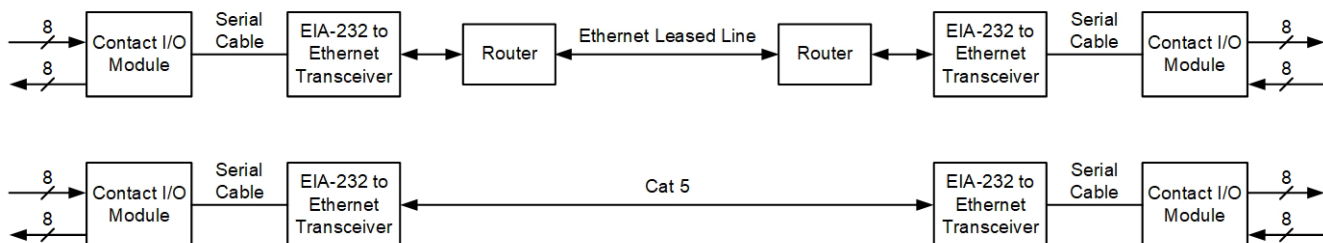

Fig. 6. DTT Scheme Topologies Using Standard Serial-to-Ethernet Transceivers

multiplexing (TDM) circuits over private packet networks that use Multiprotocol Label Switching (MPLS) or Carrier Ethernet. The approach uses the concept of VSN technology to preserve the latency and deterministic performance of TDM and synchronous optical networks (SONETs) across packet-based transport networks. It also includes an operational technology (OT) multiplexer used throughout the electric utility industry and enhanced to provide Ethernet transport. In addition, the OT multiplexer supports a wide range of traditional substation circuit interfaces including EIA-232, DTT, four-wire analog, two-wire FXO/FXS, IEEE C37.94, and T1. The VSN technology is explained in detail later in the paper. For the rest of the paper, the OT multiplexer is referred to as an OT edge node because it sits on the substation edge of the network and provides a low-latency, deterministic circuit through an Ethernet-based core network.

Consumers Energy asked if VSN technology could provide the same benefits to a leased Ethernet service as it does to private packet networks. Given that the local telecommunications carrier used Carrier Ethernet to deliver leased Ethernet services and that VSN technology was proven to provide TDM performance across private Carrier Ethernet networks, could the VSN solution offer the same performance benefits in a leased service? The only way to find out was to test it.

IX. ACHIEVING TDM PERFORMANCE USING PACKET-BASED TRANSPORT

Teleprotection interfaces such as IEEE C37.94 and MIRRORED BITS communications require a deterministic channel and the reliable transfer of data. Advanced protection methods, such as line current differential protection, have very strict latency and asymmetry requirements. The utility industry has relied on TDM communications technologies such as T1 and SONET to provide the data communications that carry teleprotection traffic. TDM is an ideal solution for teleprotection because it is a synchronous system that uses a common clock to maintain network timing. It also dedicates bandwidth to each communications circuit. TDM provides deterministic, low-latency, and low-asymmetry communications circuits with guaranteed performance unaffected by other traffic on the network.

Packet-based transport technologies alone, like MPLS and Carrier Ethernet, are unable to offer the same guaranteed latency and asymmetry performance as TDM because they are asynchronous and use shared bandwidth to transport data

efficiently and for managing a wide range of data services with varying traffic loads. When a packet-based system transports synchronous serial circuits that require low latency, the system typically requires large jitter buffers and significant bandwidth. This makes the migration of serial teleprotection channels to Ethernet very difficult [2].

VSN technology provides a way to transport serial teleprotection channels over Ethernet while maintaining TDM performance. This technology allows utilities to preserve channel performance for their protection applications even after migrating from a T1 or SONET system to one using MPLS or Carrier Ethernet [3].

VSN technology maintains a synchronous network by using a SONET engine as the primary communication method. The SONET subsystem provides a synchronous interface for each teleprotection serial circuit. On top of the SONET subsystem, an Ethernet transport system is implemented. This packetizes the native SONET data at the VT1.5 or STS level (rather than DS0) to be more bandwidth-efficient. The Ethernet packets are standard Layer 2 frames that contain the SONET data along with synchronization information and the network management system (NMS) channel.

To maintain the synchronous operation of the SONET engine, Ethernet packets are transmitted at regular intervals. As long as the packets can be transported over the MPLS or Carrier Ethernet network within an acceptable packet-delay tolerance, the system maintains synchronous operation. The VSN implementation is shown in Fig. 7. Its network requires much smaller jitter buffer sizes to manage the packet delay variation (PDV) through the core network. The Consumers Energy tests used a jitter buffer size of 800 μ s.

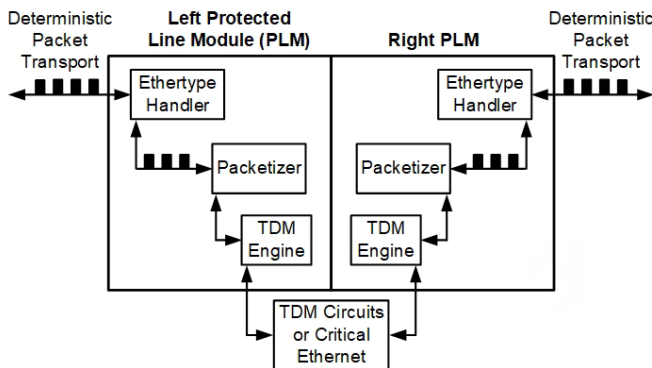

Fig. 7. VSN Implementation

By maintaining the synchronous principle of SONET, VSN technology can transport serial circuits with almost the same performance as a native SONET network. Although the end-to-end latency of VSN technology is increased because of the size of its jitter buffer, determinism is maintained and the asymmetry is also very close to that of native SONET.

VSN technology was originally designed to address the challenge of transporting substation protection circuits across packet-based networks implemented on private fiber. In this type of application, fixed or static paths are provisioned across

the core to create a ring topology, shown in Fig. 8. This topology has several benefits:

- It bundles all substation circuits into a single static path, which reduces the complexity associated with provisioning and managing separate paths for each protection circuit on the information technology (IT) network.
- It creates a demarcation between IT and OT, allowing the protection circuits to be managed by the OT team.
- It allows failover to be performed by the VSN OT edge device, which enables very fast failover (less than 5 ms).

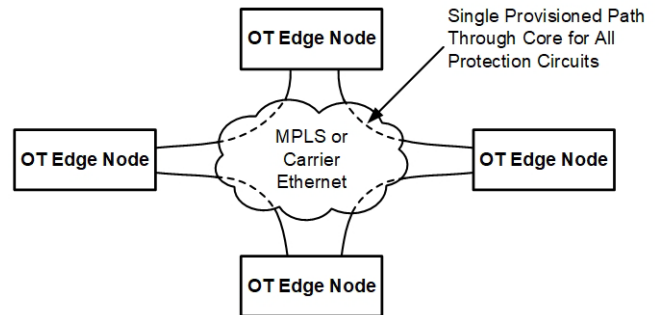

Fig. 8. VSN Ring Topology Supported by Static Paths Through Core

For a leased line implementation, the network topology is typically a simple point-to-point topology. Fig. 9 shows the configuration for a leased line point-to-point circuit. The configuration uses a single path through the carrier network. The OT edge node then provides a direct connection to all of the substation communications interface formats using a 1 Gbps Ethernet fiber interface.

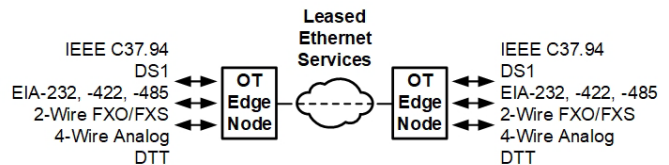

Fig. 9. VSN Technology Supports All Substation Circuits

X. FIRST TRIAL RUNNING VSN TECHNOLOGY OVER LEASED ETHERNET

For the initial trial, Consumers Energy leased a looped Ethernet circuit from a local telecommunications carrier. The starting point was the laboratory in the Consumers Energy Parnell facility. The circuit went out to the telecommunications carrier's main switch in Jackson and returned to Parnell.

Fig. 10 shows the three schemes tested in the trial. In the first two schemes, the contact I/O module was used to convert a contact input to an EIA-232 MIRRORING BITS communications data circuit. The first of those two schemes used the OT edge node to transport the EIA-232 circuit over the leased Ethernet service, and the second scheme converted the EIA-232 interface to IEEE C37.94 before transporting it using the OT

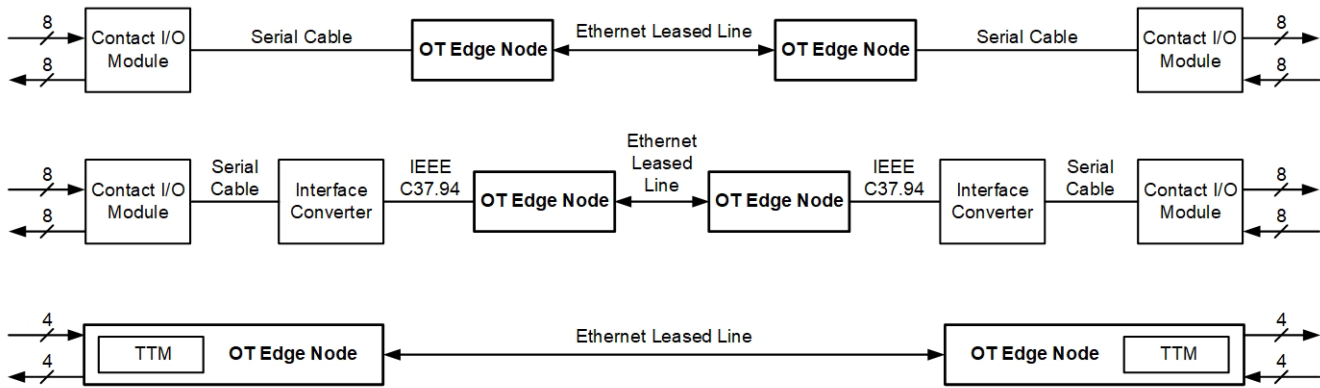

Fig. 10 Test Configurations for Initial Trial

edge node. In the final scheme of the trial, a dedicated transfer trip module (TTM) in the OT edge node was used to convert and transport the contact I/O.

Table I shows the initial trial results. A direct fiber-optic connection provided baseline measurements to serve as a control for the leased Ethernet results. Compared to the contact transfer performance that Consumers Energy achieves over existing analog leased circuits, the performance of the trial scenario with the integrated DTT contacts on the edge node demonstrates a slight timing improvement (10 ms versus 13.1 ms). When the trial results are compared against the Consumers Energy upper-limit requirement for transfer trip (32 ms), all three solutions meet this criterion.

TABLE I
INITIAL TRIAL LATENCY TEST RESULTS

Solution	Direct Fiber Optics (ms)	Leased Ethernet (ms)
Contact I/O module to edge node via EIA-232	~24	~25
Contact I/O module to transceiver to edge node via EIA-232 and IEEE C37.94	~18	~19
DTT contacts on edge node	~9	~10

XI. LIVE CIRCUIT FIELD TRIAL OF VSN TECHNOLOGY OVER LEASED ETHERNET

After running the initial trial over a period of three months and obtaining reliable and stable results, Consumers Energy was ready to perform a trial over a live circuit between Parnell and its Churchill substation. The approximately 19-mile distance between sites provided an ideal usage scenario.

Fig. 11 shows the setup for the live trial. OT edge nodes were placed at both ends of the leased Ethernet circuit, with one in the Parnell laboratory and the other in the Churchill substation. The latest official release firmware and the integrated TTM configuration was used for the live field trial. A test set measured the round trip delay. A contact closure was injected at the Parnell OT edge node and the Churchill OT edge node looped the contact output to the contact input to return the trip signal to the laboratory.

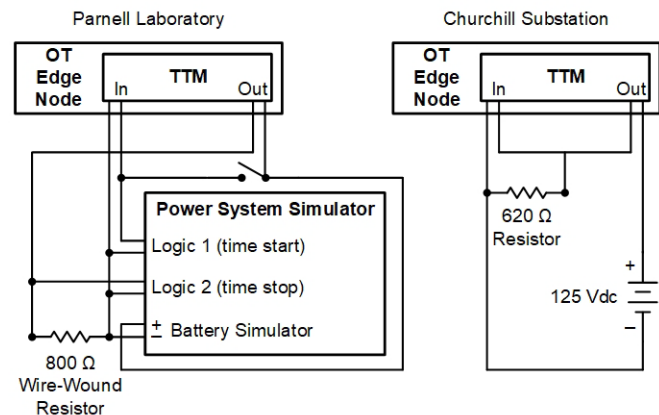

Fig. 11. Test Setup for Live Circuit Substation Trial

The TTM in the OT edge node uses a fast hybrid circuit to create the contact output. For high-speed operation, it needs to drive a low-impedance load. The test set used to measure the contact transfer latency had a high-impedance input. Placing an 800 ohm resistor across the inputs lowered the input resistance and enabled the operation of the fast hybrid circuit. By adding resistance to the outputs rather than just monitoring the contacts (particularly at the power system simulator), the measured speed of contact closure could be improved by 5 to 6 ms. Coupled with the latest firmware, this change in measurement methodology led to a noticeable improvement in end-to-end performance, despite the significant increase in physical distance between the OT edge nodes.

Fig. 12 shows the performance results. The channel performance was monitored over a period of five months. In that period, only one 24-hour interval recorded an outage that could not be accounted for. This outage lasted for 2 minutes and 33 seconds, and Consumers Energy is working with the carrier to determine the exact cause. Any other outages were attributed to running without battery backup during testing, moving equipment, or changing settings. The measured performance of the leased Ethernet circuit provided by the carrier was significantly better than its SLA of 5 ms latency. Measurements showed a latency between 0.34 and 0.38 ms and an asymmetry of 0.4 μ s. The remaining latency was caused by the OT edge

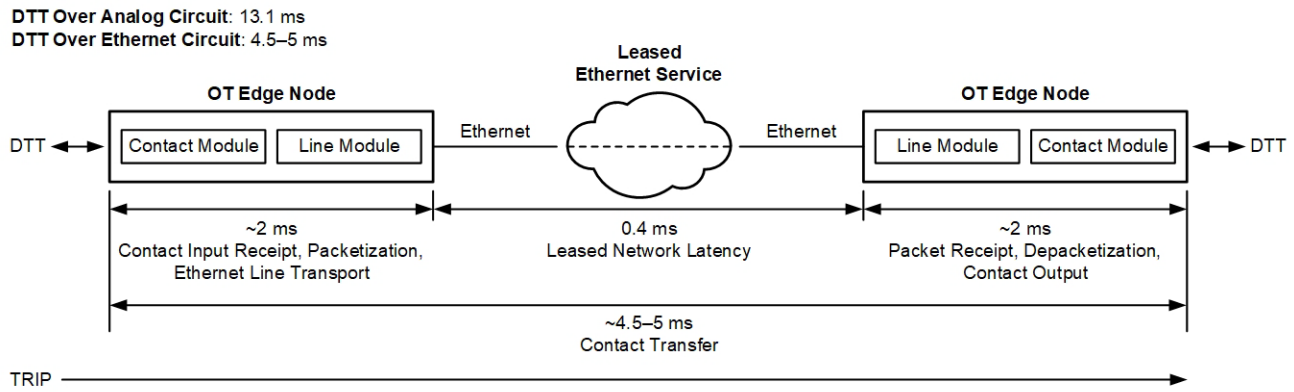

Fig. 12. Live DTT Circuit Substation Results

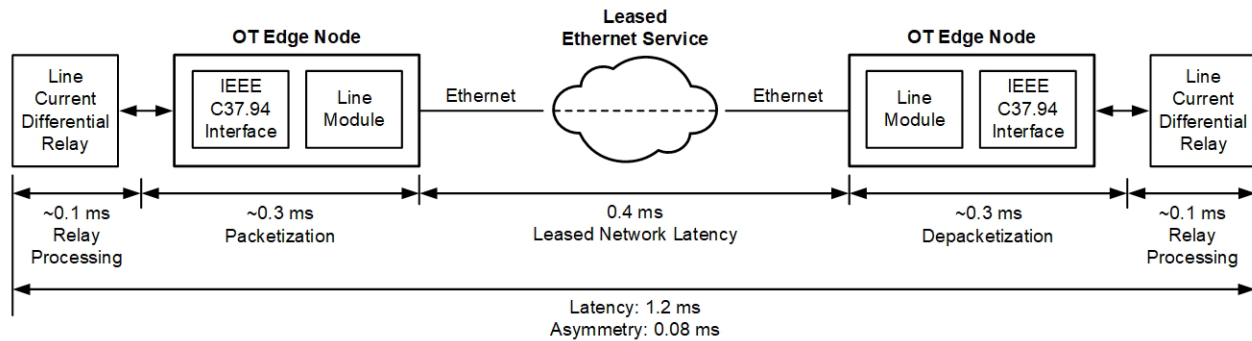

Fig. 13. Live Line Current Differential Circuit Substation Results

node at one end receiving the analog contact input, intentionally adding a de-bounce buffer and transmit delay for security, packetizing the event, and placing it on the Ethernet transport circuit. It also came from the depacketization at the other end and the generation of the analog contact output.

Because of the demonstrated flexibility and reliability of the OT edge nodes running over a leased Ethernet service, Consumers Energy plans to install another active DTT or POTT scheme using the same solution. If the operation continues to be problem-free, the solution will become the new Consumers Energy teleprotection standard for leased services.

XII. PERFORMANCE ANALYSIS OF LINE CURRENT DIFFERENTIAL PROTECTION OVER ETHERNET

From a communications-channel perspective, line current differential is considered the most challenging type of teleprotection scheme to support because of its tight latency and asymmetry requirements. For this reason, the utility industry has avoided using leased circuits to support line current differential protection schemes. However, the channel performance of the OT edge node during DTT testing, along with its interface capability, prompted Consumers Energy to consider the possibility of using VSN technology to support a line current differential circuit over leased Ethernet.

During the DTT live testing, the leased Ethernet channel latency performance was measured as a component of the overall system latency. The channel varied between 0.34 and 0.4 ms with an asymmetry of 0.3 μ s.

The OT edge node used in the DTT trials supports a wide range of relay interfaces, including IEEE C37.94. Using the OT edge node's ability to measure the separate latency of each provisioned circuit, Consumers Energy provisioned an IEEE C37.94 circuit between the Parnell office and Churchill substation in the same leased Ethernet bandwidth used for the DTT circuit and measured the latency performance of the communications channel. Based on initial testing, the end-to-end latency for an IEEE C37.94 circuit was measured as 1.2 ms at the OT edge node interface. This is within the required tolerance of 2.5 ms specified by Consumer Energy for line current differential.

Consumers Energy then installed a pair of line current differential relays into the test circuit to evaluate the performance of that system over a two-month period. The results are summarized in Table II and Fig. 13.

TABLE II
LINE CURRENT DIFFERENTIAL TRIAL PERFORMANCE RESULTS

Parameter	Line Current Differential Performance
Round trip delay	2.3 ms
Transmit delay	1.2 ms
Receive delay	1.1 ms
Asymmetry	0.08 ms
Number of dropped packets	0 (except for 1 network outage)

The relays measured these statistics. Consumers Energy felt confident that the maximum measured asymmetry of 0.08 ms and maximum one-way delay of 1.2 ms were well below the limits for the differential relays the utility typically uses. Those relays could tolerate an asymmetry of as much as 4 ms and a channel delay maximum of 70 ms.

The performance results from the live field testing were significant, with a measured level of performance equivalent to what could be expected from a private fiber network using TDM equipment. After Consumers Energy lowered its conservative jitter buffer test setting to optimize for actual channel performance, the transmit delay was reduced to 1.2 ms (from 1.7 ms) and the receive delay was reduced to 1.1 ms (from 1.6 ms).

The implications for the utility industry are far-reaching. This result opens up opportunities for using leased Ethernet circuits to support a wide variety of protection schemes, including line current differential schemes. The results from the Consumers Energy field trial show that using VSN technology over a leased Ethernet circuit delivers latency and asymmetry performance that is well within the thresholds required for line current differential protection and is comparable to the performance of a private network.

XIII. THE BUSINESS CASE FOR MIGRATION TO ETHERNET

When the impending obsolescence of leased analog is viewed from a business perspective, the primary issues Consumers Energy faces are:

- Declining reliability.
- Inability to lease new circuits.
- Rising costs.

The validation testing by Consumers Energy shows that VSN technology over leased Ethernet is reliable enough to meet performance requirements. The utility is also able to lease new Ethernet circuits when needed. As for cost, the solution requires the purchase of two OT edge node devices to provide the VSN channel. Fig. 14 shows the breakeven analysis for a single circuit, comparing the cost of leasing a 10 Mbps Ethernet service (the target Consumers Energy bandwidth) to the cost of leasing an analog line. Even with the higher initial price of the Ethernet service (resulting from new circuit installation by the carrier and the purchase of two OT edge node devices), leasing an Ethernet circuit is cheaper than leasing an analog one after only 26 months.

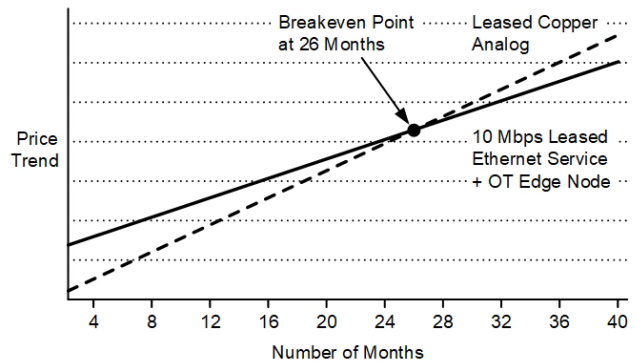

Fig. 14. Breakeven Analysis of Analog Versus 10 Mbps Ethernet for Single Leased Circuit (including two endpoints)

XIV. CONCLUSION

The Consumers Energy leased Ethernet trials established that an OT edge node with VSN technology can provide a protection channel solution for DTT, POTT, and line current differential schemes following a migration from leased analog to Carrier Ethernet circuits. The DTT latency performance of 4.5 to 5 ms with the OT edge node is significantly better than the current analog circuit latency performance of 13.1 ms. The solution's reliability performance also met performance targets set by Consumers Energy.

From a cost perspective, a 100 Mbps Ethernet service is currently cost-neutral compared to average analog pricing. A 10 Mbps service is available at a discounted price, and the savings from that discount would pay for the cost of installing new OT edge network equipment in 26 months.

Beyond DTT, performance testing of an IEEE C37.94 line current differential channel shows that VSN technology over a leased Ethernet circuit can support a line current differential protection scheme. This could be very significant for the utility industry. Line current differential is a widely used protection method with very stringent communications channel requirements. In the past, utilities considered it impossible to use leased Ethernet for line current differential protection because of the challenge of meeting latency and asymmetry requirements. With VSN technology, it is now possible. To be viable, it may require the carrier to be able to provide a sub-5 ms SLA to guarantee the leased Ethernet circuit performance if high-speed tripping is a concern. However, if it is possible to delay tripping by as much as 5 ms without significant consequences, then this is a workable solution.

By adopting an innovative VSN approach to substation TDM, utilities can solve the imminent challenge of analog leased line obsolescence and still maintain protection channel performance and reliability.

XV. REFERENCES

- [1] IEEE 487-2015, IEEE Standard for the Electrical Protection of Communications Facilities Serving Electric Supply Locations—General Considerations.
- [2] E. O. Schweitzer, III, D. Whitehead, K. Fodero, and P. Robertson, “Merging SONET and Ethernet Communications for Power System Applications,” proceedings of the 38th Annual Western Protective Relay Conference, Spokane, WA, October 2011.
- [3] K. Fodero, C. Huntley, and P. Robertson, “Deterministic Communications for Protection Applications Over Packet-Based Wide-Area Networks,” proceedings of the 71st Annual Conference for Protective Relay Engineers, College Station, TX, March 2018.

XVI. BIOGRAPHIES

Jonathan Geurink is a Senior Engineer II in the Electric Transmission and High Voltage Distribution Protection group at Consumers Energy in Jackson, Michigan. Jonathan has over 9 years of engineering experience with Consumers Energy and spent 7 of those years in System Protection. Beyond power system protection, Jonathan has a technical interest in computers, networking, and programming. He plays a large role in maintaining the group’s software and databases. He has a BS in electrical engineering from Michigan Technological University and is a licensed Professional Engineer in Michigan.

Kenneth Fodero is a research and development manager for the communications product lines at Schweitzer Engineering Laboratories, Inc. (SEL). Before coming to SEL, he was a product manager at Pulsar Technologies for 4 years in Coral Springs, Florida. Prior to Pulsar Technologies, Ken worked at RFL Electronics for 15 years, and his last position there was director of product planning. He is a member of IEEE and has authored and presented several papers on power system protection communications topics.

Paul Robertson is a senior product manager for the wireless networking communications product line at Schweitzer Engineering Laboratories, Inc. (SEL). He has over 25 years of experience developing and marketing products for the telecommunications industry, spanning cellular wireless and wireline communications systems. Paul worked in various technical and marketing roles for Motorola, Hewlett-Packard, and Agilent Technologies before joining SEL. He has a BEng in electrical and electronic engineering from the University of Strathclyde and an MBA from Edinburgh Business School.