



SEL-3360-2 Compact Industrial Automation Controller

Improve Reliability, Availability, and Serviceability With a Rugged, Compact Industrial Automation Controller



The SEL-3360-2 Compact Industrial Automation Controller uses a high-performance x86-64 architecture processor to support modern operating systems like Microsoft Windows and Linux. The extremely rugged SEL hardware of the SEL-3360-2 enables you to use your choice of automation controller operating system and software in very harsh environments not suitable for general purpose computers.

Integrate the SEL-3360-2 in computing applications that demand high performance, reliability, and low maintenance in extreme, harsh environments. The SEL-3360-2 offers a mean time between failure (MTBF) of at least ten times that of typical industrial automation controllers by eliminating all moving parts, including rotating hard drives and fans; using high-quality solid-state drives; and by using error-correcting memory technology. By eliminating vent holes, the SEL-3360-2 significantly reduces dust buildup and foreign contaminants. Power the SEL-3360-2 from 12 Vdc power sources with voltage ranging from 10.0–16.6 Vdc, enabling simple integration with common power sources and battery-powered systems with high float-charge levels. You can install software from SEL and third-party software vendors to customize the SEL-3360-2 for your specific applications. Every SEL-3360-2 comes with the unprecedented ten-year, worldwide SEL warranty.

Major Features and Benefits

The SEL-3360-2 provides a rugged, easy-to-use automation controller platform for substation, industrial, or other harsh environments.

- **x86-64 Architecture.** The SEL-3360-2 uses the Intel Xeon E3 microprocessor architecture to deliver very high performance and broad operating system and software compatibility. Multiple processor cores and Intel Hyper-Threading Technology enable you to run multiple time-critical applications simultaneously. Choose between 2.0 GHz and 2.8 GHz quad-core CPU options.
- **Operating System Choices.** The SEL-3360-2 may be purchased as hardware only, or with a variety of modern Microsoft Windows operating systems to provide extreme flexibility and functionality along with enhanced security features.

- **Form Factor.** The SEL-3360-2 provides a compact wall-mount chassis, designed for substation and industrial control applications. The system includes rear-panel I/O connectors for network, peripherals, storage, video, audio, alarm, and serial I/O—all with protection against electrical shock and surge.
- **Power Supply.** The SEL-3360S-2 can be powered from any 12 Vdc source, such as the robust, reliable SEL-9331 power supply module. The SEL-3360E-2 has an integral power supply that can be powered from low- and high-voltage ac and dc power sources.
- **Mass Storage.** The SEL-3360-2 supports two 2.5-inch SATA drives, which are hot-swappable and accessible after removing the right-side panel. High-performance, industrial-rated solid-state drives (SSD) are available as ordering options.
- **RAID.** The integrated SATA controller supports Redundant Array of Independent Disks (RAID) configurations to maximize data availability and improve storage volume performance.
- **Display Interfaces.** DVI, DisplayPort, or HDMI video connections enable you to connect as many as three simultaneous, independent, high-definition displays.
- **Audio Interface.** Analog HD audio inputs and outputs enable connection to amplified speakers, microphone, and audio sources for clear audible user feedback, audio capture and analysis, and voice recognition. Digital audio can be streamed through the digital display interfaces for simple integration and high-definition surround-sound.
- **USB Connectivity.** The SEL-3360-2 has four rear-panel and two front-panel USB ports for connection to a local keyboard, mouse, and any USB peripherals. Each port is individually current limited, protecting the system from external short circuits, and enabling high-power devices such as USB hard drives to be powered from any USB port.
- **PCIe Expansion.** The SEL-3360E-2 supports as many as two standard PCIe form factor expansion cards, enabling you to customize the system I/O to meet your application needs. Choose from a selection of SEL PCIe expansion cards, or install your own custom third-party expansion card.
- **Ethernet.** Two 10/100/1000 Mbps Ethernet connections on the rear panel support high-speed network connectivity and enable connections to independent networks, or redundant paired network connections. Network interface cards such as the SEL-3390E4 quad-gigabit Ethernet card can be added to the SEL-3360E-2 for additional network connectivity.
- **Serial I/O.** Two standard EIA-232 serial ports enable connection to nearby electronic devices such as automation controllers, communication radios, and modems. As many as two SEL-3390S8 serial expansion cards can be added to the SEL-3360E-2 for applications that require many serial I/O connections and IRIG time synchronization and distribution.
- **System Monitoring and Watchdog.** An embedded controller works in unison with the SEL SysMon software to provide an extra level of automation controller system reliability and detect failures in the application software or operating system. The system logs any abnormal conditions, enables the system alarm to alert operators of a problem, and if necessary, can restart the system to return to a good operation state.
- **Alarm Contact Output.** SEL SysMon software controls the alarm contact output to signal in case of system health problems or malfunctions. The Form C contact supports both normally open and normally closed alarm operation.
- **Remote Management.** The SEL-3360-2 supports remote access over Ethernet by using Windows Remote Desktop or Intel vPro Active Management Technology (AMT), enabling full access to the system video, keyboard, mouse, and storage.

Functional Overview

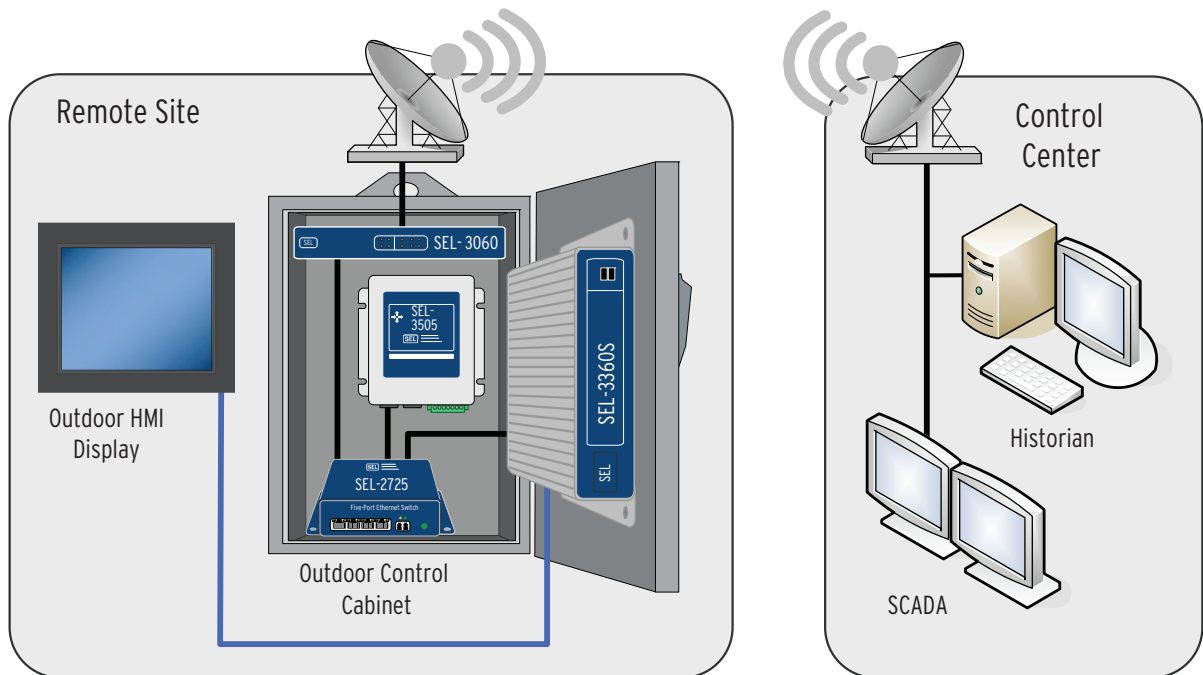

Figure 1 SEL-3360-2 in Monitoring and Control Applications

Watchdog Functionality

An embedded controller provides an extra level of automation controller system reliability. One function of the embedded controller is to restart the automation controller if there is an operating system problem or a problem with specific software services running on the operating system.

SEL System Monitor

SEL System Monitor software monitors system performance and component health. Alerts for alarm conditions are issued on configurable thresholds. Example thresholds include CPU usage, free disk space, and available system memory.

Ethernet

Ethernet connections allow the SEL-3360-2 to connect to two separate, high-speed Ethernet networks via built-in Gigabit Ethernet. Aggregate ports for increased performance or redundancy or separate local area networks (LANs) for control, data, or engineering access. Additional copper or fiber-optic Ethernet ports can be added to the SEL-3360E-2 by installing PCI Express expansion cards such as the SEL-3390E4. For information on those cards, please refer to the appropriate expansion card instruction manual.

Time

The COM1 serial port accepts IRIG-B time-code input for precise time input from a GPS clock or other source.

EIA-232 Serial Ports

The SEL-3360-2 automation controller platform has two built-in EIA-232 DB-9 ports, which can provide +5 V power to run external transceivers, modems, and other serial-connected accessories. Additional serial ports can be added to the SEL-3360E-2 by installing PCI Express expansion cards such as the SEL-3390S8. For information on those cards, please refer to the appropriate expansion card instruction manual.

Alarm Output

An alarm contact output on the rear panel can be used to signal internal errors and operating system malfunctions.

Programmable LEDs

Program three front-panel bicolor LEDs for use with your custom applications.

Out-of-Band Management

Intel vPro Active Management Technology (AMT) provides out-of-band management for security, configuration, and monitoring.

Applications

Virtualization for HMI and Other Applications

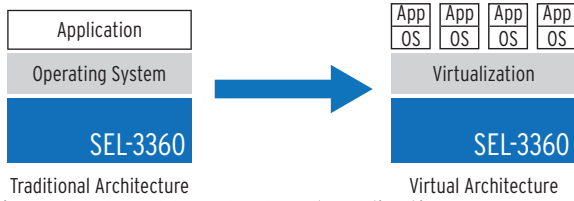

Figure 2 SEL-3360-2 OS and Application Virtualization Platform

Create your own virtualization appliance by leveraging Intel Virtualization Technology (VT-x) to allow one hardware platform to function as multiple “virtual” platforms. Isolate your automation controlling activity onto separate virtual machines to maintain productivity and realize improved manageability and reduced downtime. For example, run a virtualized OS specifically for your HMI or other essential but noncritical applications. Should your HMI require that the system be restarted, simply restart the virtual machine and avoid an outage for your other critical processes. Similarly, multiple SEL-3360-2 automation controller platforms may be virtualized and entire operating systems transparently migrated from one physical SEL-3360-2 to another for hardware upgrades, security or software updates, or testing purposes.

Control System Applications

Use the SEL-3360-2 for process control applications, including as an HMI or for protocol conversion and high-speed control when working with other SEL products and solutions.

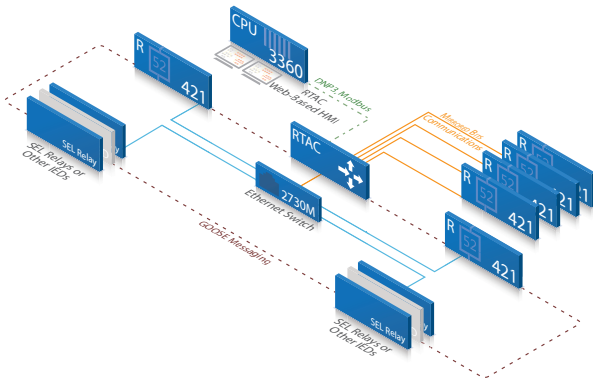

Figure 3 High-Speed Control With SEL MIRRORING BITS and IEC 61850 GOOSE Communications

Security Applications

Improve security with a single sign-on, enabled through using the SEL-3360-2 as a local Lightweight Directory Access Protocol (LDAP) server. Centrally manage user accounts and group memberships with Microsoft Active Directory or with your choice of back-end database support.

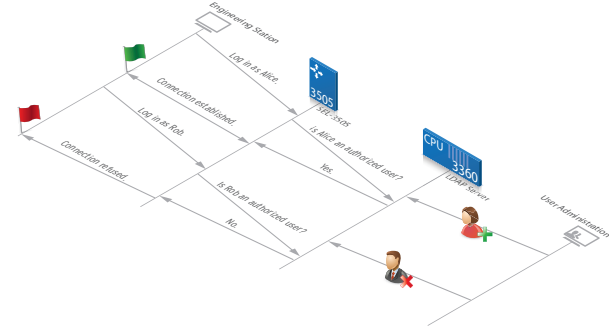

Figure 4 SEL-3360-2 as Remote Read-Only Domain Controller Performing Central Authentication Using LDAP

Disturbance Recording System for PRC-002-2

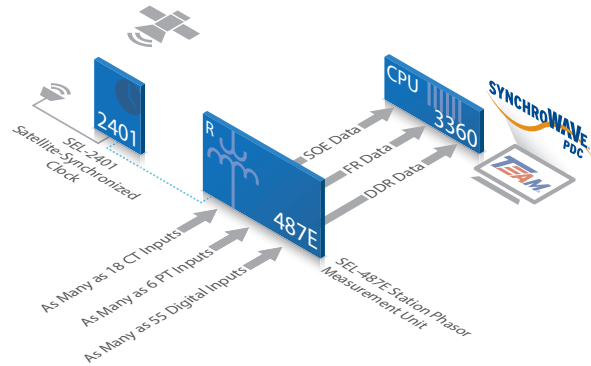

Figure 5 Reliable Hardware for Running Your Disturbance Recording System

Event Collection Applications

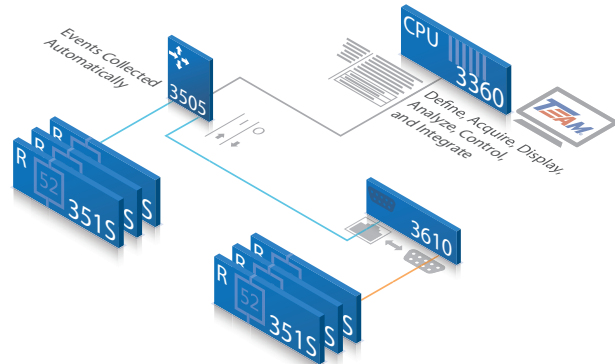
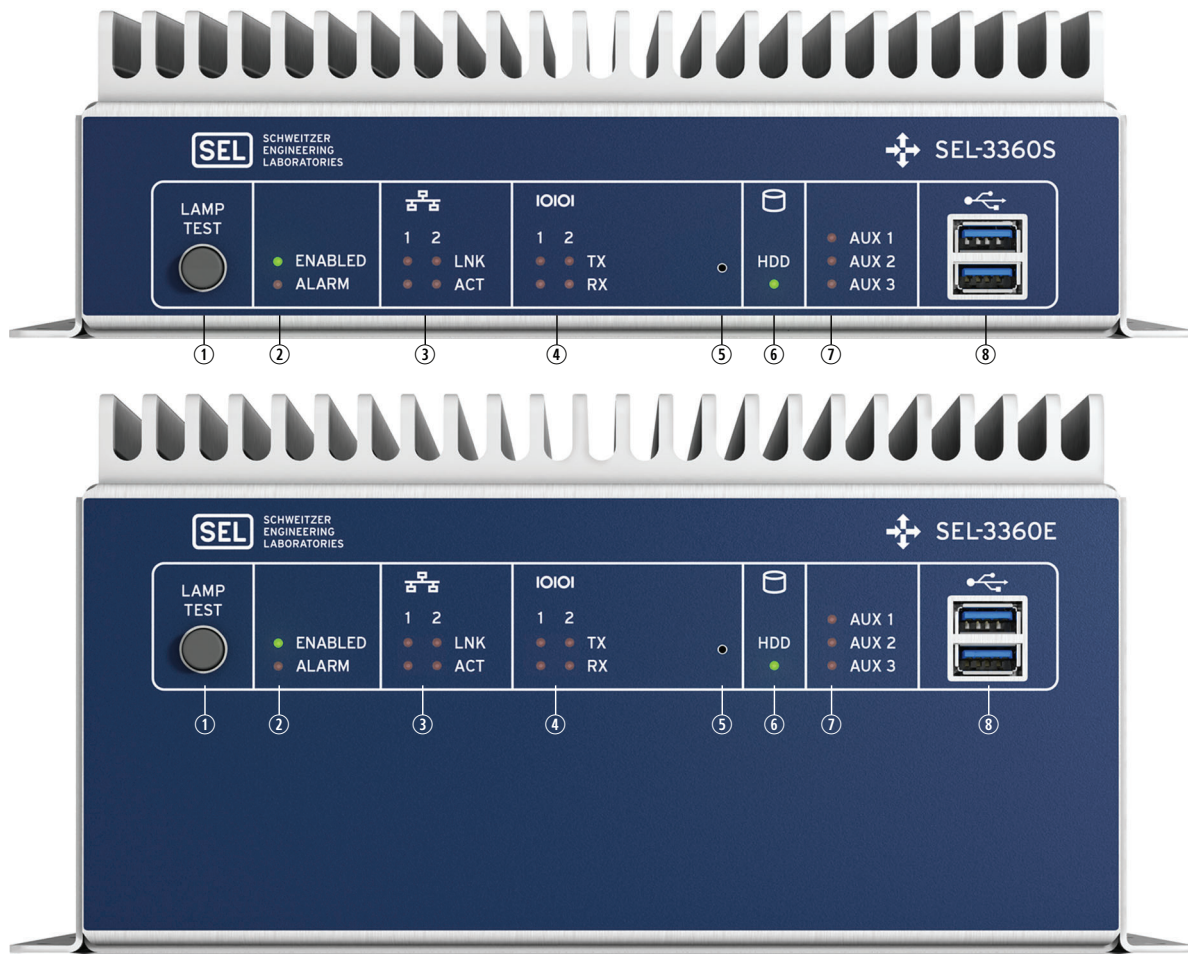

Figure 6 IED Event Collection With Optional ACCELERATOR TEAM® SEL-5045 Software

Front- and Rear-Panel Diagrams



- ① **LAMP TEST** Button. Press and hold to test front-panel LEDs. Can be programmed to be an on/off or reset button.
- ② **ENABLED** and **ALARM** LEDs provide operational status. A green **ENABLED** LED indicates normal operation. The **ALARM** LED illuminates red when a nonoptimal system condition exists.
- ③ **ETHERNET** Status Indicators. Link (**LNK**) indicates that the port is connected, and activity (**ACT**) indicates when data are being transmitted and received.
- ④ **SERIAL** Status Indicators. Transmit (**TX**) and receive (**RX**) LEDs indicate activity on serial ports.
- ⑤ **PINHOLE** button. Provides reset and power functions; requires a pushpin to prevent accidental use.
- ⑥ **HDD** Activity Indicator. Illuminates when SATA drives are accessed.
- ⑦ **AUXILIARY** Status Indicators. Three programmable, bicolor LEDs for your custom application.
- ⑧ **USB** Ports. Two easily accessible ports to connect USB 3.1 peripherals.

Figure 7 Front-Panel Diagram

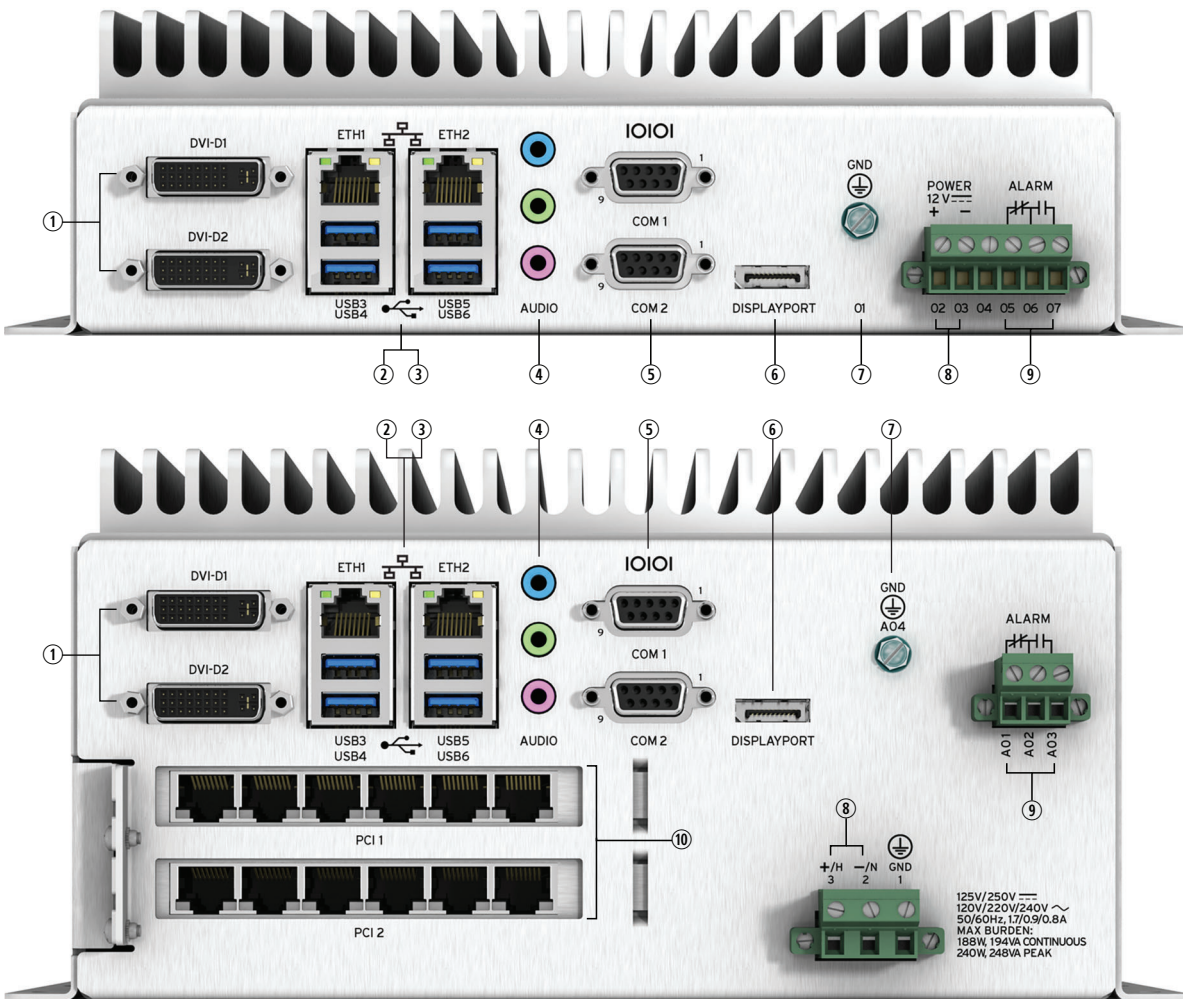

- ① **DVI-D.** Connect digital monitors by using native DVI or an HDMI adapter.
- ② **ETH1** and **ETH2.** Onboard independent Gigabit Ethernet interfaces.
- ③ **USB** Ports. Connect as many as four USB 3.1 peripherals at the rear panel.
- ④ **AUDIO** Ports. Line Input (blue), Line Output (green), and Microphone Input (pink).
- ⑤ **COM1** and **COM2.** Standard EIA-232 serial ports with configurable +5 Vdc power on Pin 1.
- ⑥ **DISPLAYPORT.** Connect new digital monitors supporting the DisplayPort interface.
- ⑦ **GROUND** Terminal Screw. The earth ground connection for the SEL-3360-2.
- ⑧ **POWER** Input Terminals. The rated input voltage is clearly marked on the chassis near the terminals.
- ⑨ **ALARM.** The Form C alarm contact output enables both normally closed and normally open wiring connections.
- ⑩ **PCI** Expansion Slots. Install SEL or third-party PCI Express expansion cards for additional network, serial, or other application-specific I/O.

Figure 8 Rear-Panel Diagram

Product Dimensions

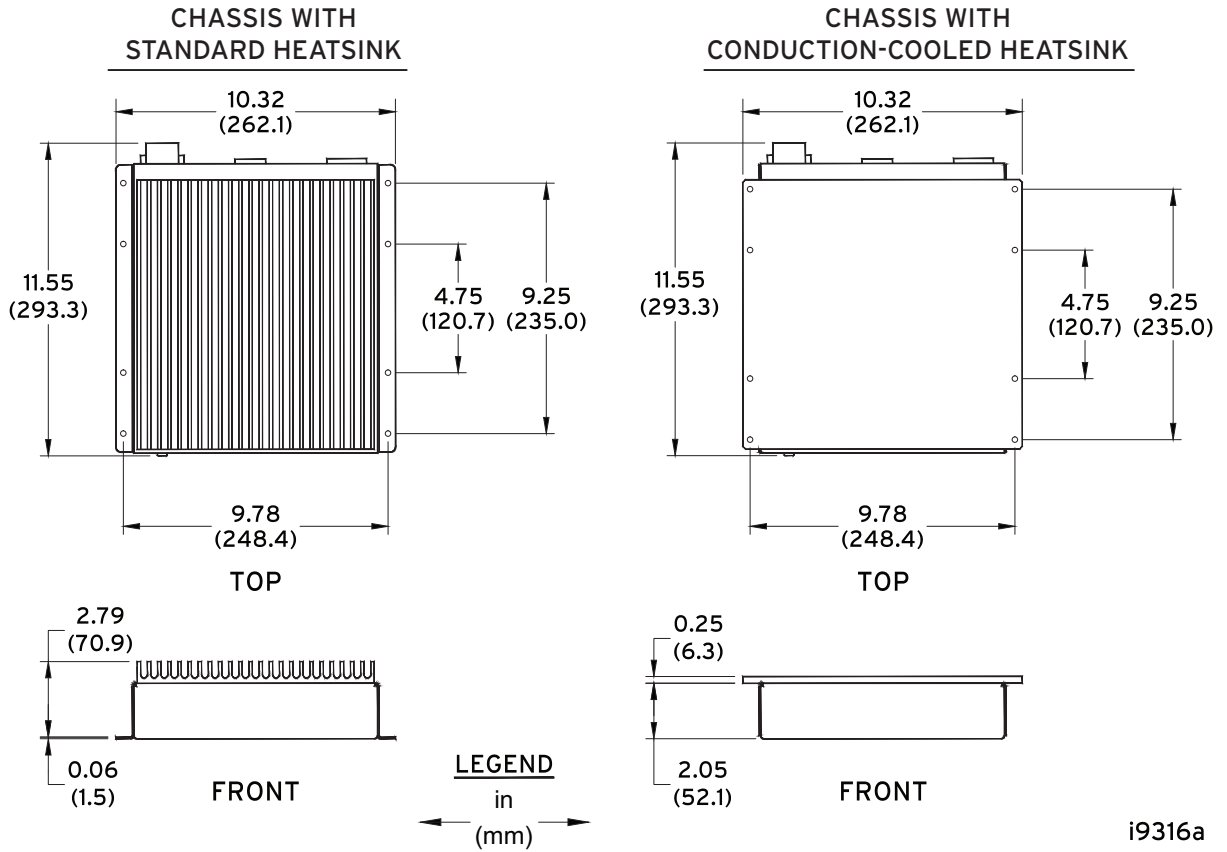

Figure 9 SEL-3360S Dimensions Diagram

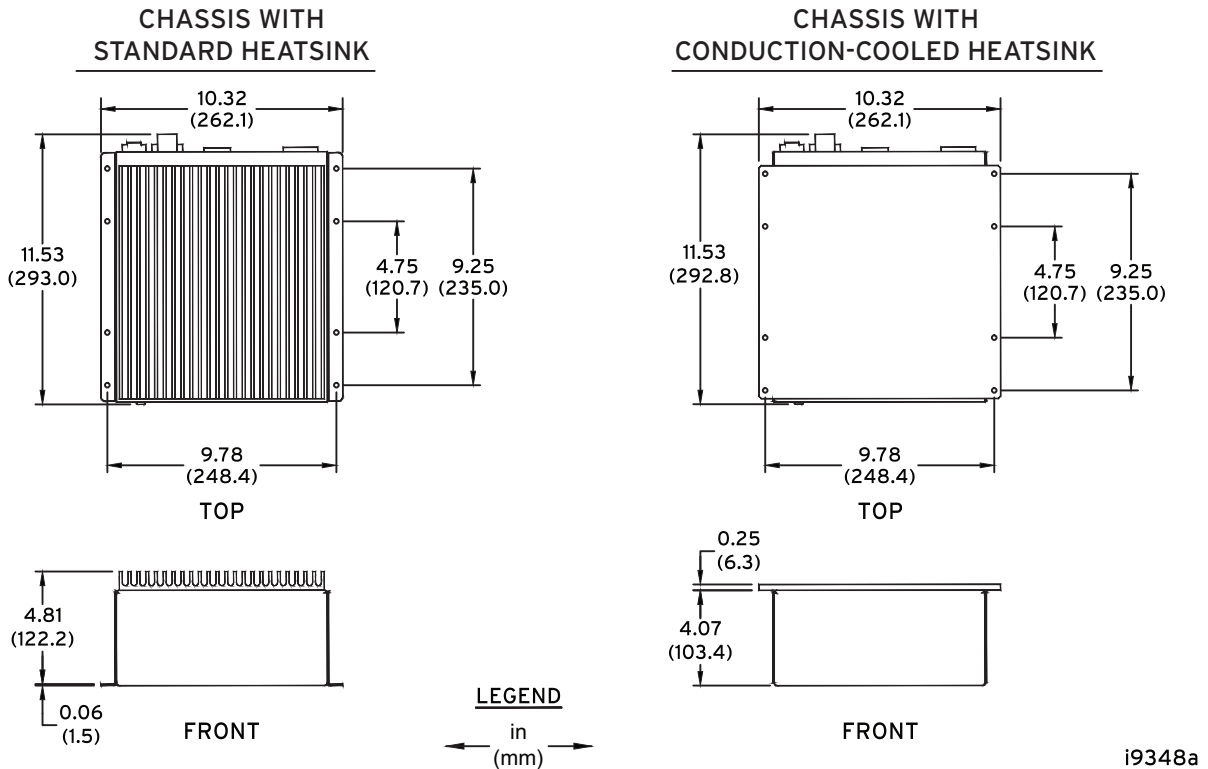

Figure 10 SEL-3360E Dimensions Diagram

Specifications

Compliance

Designed and manufactured under an ISO 9001 certified quality management system

47 CFR 15B, Class A

Note: This equipment has been tested and found to comply with the limits for a Class A digital device, pursuant to part 15 of the FCC Rules. These limits are designed to provide reasonable protection against harmful interference when the equipment is operated in a commercial environment. This equipment generates, uses, and can radiate radio frequency energy and, if not installed and used in accordance with the instruction manual, may cause harmful interference to radio communications. Operation of this equipment in a residential area is likely to cause harmful interference, in which case the user will be required to correct the interference at his own expense.

UL Recognized to U.S. and Canadian safety standards (File E220228; NRAQ)

CE Mark

UKCA Mark

RCM Mark

RoHS Compliant

General

SEL Operating Systems

SEL Real-Time Automation Controller (RTAC)^a
SEL Blueframe

Supported Third-Party Operating Systems

Microsoft Windows: 8, 10^b, 11 IoT LTSC^b
Microsoft Windows Server: 2012, 2016^b, 2019^b, 2022^b
CentOS Linux^c: 6, 7
Red Hat Enterprise Linux^c: 6, 7, 8, 9
Ubuntu Linux^c: 16.04, 18.04, 20.04, 22.04, 24.04 LTS
VMware ESXi^c: 7, 8
OpenSUSE^c: 15
SUSE Enterprise Linux^c: 15

^a Available via SEL-3533 RTAC Conversion Kit.

^b Factory-installed option.

^c Limited support for system Alarm, Watchdog, and AUX LEDs.

Note: For the optional SEL-3390S8, SEL-3390E4, and SEL-3390T expansion cards, refer to their instruction manuals for their supported operating systems.

CPU

Intel Xeon E3-1505L Quad-Core

Speed: 2.0 GHz base, 2.8 GHz turbo

Cache: 1 MB L2, 8 MB L3

Intel Xeon E3-1505M Quad-Core (SEL-3360S-2 Only)

Speed: 2.8 GHz base, 3.7 GHz turbo

Cache: 1 MB L2, 8 MB L3

RAM

4–64 GB DDR4 ECC PC4-17000 (2133 MHz)

Chipset

Intel CM236 Express Chipset

Expansion Cards (SEL-3360E-2 Only)

2 Half-Length, Full-Height PCI 1: PCIe x1 (Revision 2.0)
PCI Expansion Card Slots: PCI 2: PCIe x4 (Revision 2.0)

PCI Card Power Limits:

PCIe x4: ≤17 W

PCIe x1: ≤10 W

Total Combined: ≤17 W

Mass Storage

Internal Drive Bay: Supports 2.5 inch SATA drives
two industrial-grade drives,
one consumer-grade drive
Intel CM236 SATA Controller provides
standard AHCI and Intel RST RAID
modes
SATA II 3.0 Gb/s
RAID level 0, 1
Hot-Swap Support

Optional SATA Drives: Industrial-Grade SLC SSD
30–250 GB
10-year warranty
Industrial-Grade pSLC SSD
120–480 GB
5-year warranty
Industrial-Grade 3D TLC SSD
240–7680 GB
5-year warranty
Consumer-Grade MLC SSD
240–1920 GB
3-year warranty

Real-Time Clock/Calendar

Battery Type: IEC No. BR-2330A Lithium

Battery Life: 10 years with power
2 years without power

Drift: 200 ppm

BIOS

AMI UEFI

Trusted Platform Module

Infineon SLM 9670AQ TPM 2.0

Intel Active Management Technology

Intel AMT v11, accessible through ETH1

Operating Environment

Operating Temperature Range

SEL-3360S-2 With
E3-1505L CPU: –40° to +75°C (–40° to +167°F)

SEL-3360S-2 With
E3-1505M CPU: –40° to +60°C (–40° to +140°F)

SEL-3360E-2 With
E3-1505L CPU: –40° to +60°C (–40° to +140°F)

* Requires Industrial-Grade SSDs. See SEL Application Note, "Determining Solid-State Drive (SSD) Lifetimes for SEL Automation Controllers" (AN2016-03).

Note: UL ambient 40°C. See the instruction manual safety information for additional restrictions.

Storage Temperature Range

–40° to +85°C (–40° to +185°F)

Relative Humidity 5% to 95% noncondensing

Insulation Class 1

Pollution Degree 2

Overvoltage Category:

Category	Maximum Altitude	Atmospheric Pressure
Category II	5,000 m	80–110 kPa

Weight

4 kg (9 lb) maximum (SEL-3360S-2)
7 kg (15 lb) maximum (SEL-3360E-2)

Peripheral Connections

Video

Intel P530 Graphics Controller

As many as three total displays using any combination of DVI and/or DisplayPort outputs:

DVI-D outputs:
One display per output
Maximum resolution*: 1920 x 1080 @ 60 Hz
Digital output only; does not support passive VGA adapters
DisplayPort 1.2 output
As many as three displays via DisplayPort MST
Maximum resolution*: 4096 x 2304 @ 60 Hz (one display)
1920 x 1200 @ 60 Hz (three displays)
Cable length < 10 m for Surge Immunity compliance.

*High-resolution displays require high-quality cables. Ensure your display cables are as short as possible and rated for the required screen resolution.

Audio

TSI (IDT) 92HD91 HD Audio Codec

3 Analog 3.5 mm TRS Jacks: Line input
Line/headphone output
Microphone input
Cable length <2 m for Electromagnetic Compatibility Immunity compliance

Intel Display Audio

Digital Audio Outputs: DVI-D1, DVI-D2, DisplayPort

USB

4 Rear-Panel Ports, 2 Front-Panel Ports
USB 3.2 Gen 1 (SuperSpeed USB 5 Gbps)
2000 mA Maximum Current Each
Cable length <2 m for Electromagnetic Compatibility Immunity compliance
2 Internal Ports on 1 Main Board Header
USB 2.0 (High Speed USB 480 Mbps)

Communications Ports

Ethernet

2 Rear-Panel, 1 Gbps Copper RJ45 Ports

ETH1: Intel WGI219LM, 10/100/1000 Mbps RJ45 copper

ETH2: Intel WGI210IT, 10/100/1000 Mbps RJ45 copper

Optional SEL-3390E4 or SEL-3390T Expansion Card (SEL-3360E-2 Only): As many as four additional 10/100/1000 Mbps ports, copper or LC fiber SFP

Note: See SEL-3390E4 and SEL-3390T instruction manuals for additional information.

Serial Ports

Standard Ports: 2 EIA-232 ports, DB-9 connectors
300 to 115200 bps

(Meets EIA/TIA-562 Specifications)

Optional SEL-3390S8 Expansion Cards (SEL-3360E-2 Only): As many as 12 additional EIA-232/EIA-422/EIA-485 ports, RJ45 connectors
300 to 921600 bps

Note: See the SEL-3390S8 instruction manual for additional information.

Time-Code Inputs and Outputs

Main Board (Input Only)

Connector: COM1 DB-9 serial port

Time Code: Demodulated IRIG-B TTL compatible

Optional SEL-3390S8 Expansion Card (Input/Output) (SEL-3360E-2 Only)

Connector: RJ45 serial port

Time Code: Demodulated IRIG-B TTL compatible

Note: See the SEL-3390S8 instruction manual for additional information.

Optional SEL-3390T Expansion Card (Input/Output)

Connector: BNC

Time Code: Demodulated IRIG-B TTL compatible

Note: See the SEL-3390T instruction manual for additional information.

Note: Outputs generated from either IRIG-B input or SEL-3360-2 clock.

Power Supply

See *Table 1* for additional burden information.

No Power Supply (SEL-3360S-2 Only)

Voltage Rating: 12 Vdc

Voltage Range: 10–16.6 Vdc

Typical Burden: 25 W

Max Burden: 144 W (cold startup)

Peak Inrush: 15 A

Negative input power terminal is internally tied to chassis ground.

SEL-9331 160 W LV Power Supply

Voltage Rating: 48 Vdc

Voltage Range: 38–58 Vdc

Maximum Constant Burden

External SEL-9331: 149 W

Internal SEL-3360E-2: 178 W

Maximum Peak Burden: 225 W

DC Ripple: <15% rated voltage

Peak Inrush: 15.5 A peak, 48 ms duration
Measured per IEC 60255-1, Section 6.10. Quiescent current level derived from 40 W input.

Interruption: 100 ms @ 48 Vdc

Insulation: 3600 Vdc

Input Isolated From Chassis Ground: Yes

SEL-9331 160 W HV Power Supply

Voltage Ratings: 125/250 Vdc
120/220/240 Vac; 50/60 Hz

DC Range: 100–300 Vdc

Maximum DC Dropout: 88 Vdc

AC Range: 85–264 Vac

Frequency Range: 45–65 Hz

Maximum Constant Burden	
External SEL-9331:	155 W, 160 VA
Internal SEL-3360E-2:	188 W, 194 VA
Maximum Peak Burden:	240 W, 248 VA
DC Ripple:	<15% rated voltage
Peak Inrush:	16.6 A peak, 4 ms duration, 240 Vac 12.8 A peak, 9 ms duration, 250 Vdc Measured per IEC 60255-1, Section 6.10. Quiescent current level derived from 75 W input.
Interruption:	200 ms @ 125 Vdc/120 Vac
Insulation:	3600 Vdc
Power Factor:	>0.9 (at full load)
Input Isolated From Chassis Ground:	Yes

Recommended External Overcurrent Protection

Breaker Type:	Standard
Breaker Rating:	20 A at 250 Vdc
Current Breaking Capacity:	10 kA
Grounded Neutral Systems:	Devices in series with the HOT or energized conductor
DC and Isolated Systems:	Device in serial with both conductors
Distance from Equipment:	Less than 2 m

Fuse Ratings

12 Vdc Input Power Fuse F1:	15 A, 250 Vac/60 Vdc fast acting 60 Vdc/50 A break rating
LV Power Supply Fuse	
Rating:	15 A
Maximum Rated Voltage:	500 Vdc, 500 Vac
Breaking Capacity:	20 kA at 500 Vdc
Type:	Time-lag T
HV Power Supply Fuse	
Rating:	5 A
Maximum Rated Voltage:	250 Vdc, 277 Vac
Breaking Capacity:	1500 A at 277 Vac
Type:	Time-lag T
Heater Fuses F2, F3:	5 A, 125 V slow blow 125 Vdc/50 A break rating

Note: Fuses are not serviceable.

Contact Inputs and Outputs

Alarm Output Contact

Output Type:	Relay, Form C, break-before-make
Pilot Duty Ratings*:	B300 (UL) R300 (UL)
Rated Voltage**:	24–250 Vdc 110–240 Vrms
Note: The voltage across any of the contact output terminals must not exceed the operational voltage.	
Operational Voltage**:	0–300 Vdc 0–264 Vrms
Contact Protection:	MOV protection across open contacts 264 Vrms continuous voltage 300 Vdc continuous voltage
Continuous Carry**:	6 A @ 70°C, 4 A @ 85°C
Pickup/Dropout Time**:	≤6 ms (resistive load)

Power Supply Burden**:	≤1 W
Mechanical Endurance**:	10,000 no-load operations
Make (Short Duration Contact Current)**:	30 Adc 1,000 operations @ 250 Vdc 2,000 operations @ 125 Vdc

Note: 200 ms on, 15 ms off, current interrupted by independent means.

Short-Time Thermal Withstand**:	50 A for 1 s
Limiting Making Capacity**:	1,000 W @ 250 Vdc (L/R = 40 ms)
Limiting Breaking Capacity/Electrical Endurance**:	10,000 operations 10 operations in 4 s, followed by 2 min idle

Rated Voltage	Resistive Break	Inductive Break L/R = 40 ms (DC) PF = 0.4 (AC)
24 Vdc	1.25 Adc	1.25 Adc
48 Vdc	0.63 Adc	0.63 Adc
125 Vdc	0.30 Adc	0.30 Adc
250 Vdc	0.20 Adc	0.20 Adc
110 Vrms	0.30 Arms	0.30 Arms
240 Vrms	0.20 Arms	0.20 Arms

* Per UL 508.

** Parameters verified by SEL per IEC 60255-1:2009 and IEEE C37.90-2005.

Terminal Connections

Compression Screw Terminal

Power Wiring	
Insulation:	300 V min.
Size:	12–14 AWG, length <2 m
Alarm Wiring	
Insulation:	300 V min.
Size:	12–18 AWG
Tightening Torque	
Minimum:	0.6 Nm (5 in-lb)
Maximum:	0.8 Nm (7 in-lb)
Crimp Ferrule Recommended	
Mounting Ear Tightening Torque	
Minimum:	0.18 Nm (1.6 in-lb)
Maximum:	0.25 Nm (2.2 in-lb)

Grounding Screw

Ground Wiring	
Insulation:	300 V min.
Size:	12 AWG, length <3 m
Tightening Torque	
Minimum:	0.9 Nm (8 in-lb)
Maximum:	1.4 Nm (12 in-lb)
Ring Terminal Recommended	

Serial Port

Tightening Torque	
Minimum:	0.6 Nm (5 in-lb)
Maximum:	0.8 Nm (7 in-lb)

Video Port

Tightening Torque

Minimum:	0.6 Nm (5 in-lb)
Maximum:	0.8 Nm (7 in-lb)

Product Standards

Communications Equipment in Utility Substations:	IEC 61850-3:2013 IEEE 1613-2009 Severity Level: Class 1
Industrial Environment:	IEC 61000-6-2:2005 IEC 61000-6-4:2006
Electrical Equipment for Measurement, Control, and Laboratory Use:	IEC 61010-1:2010/AMD1:2016/ COR:2019 UL 61010-1:2019, C22.2 No. 61010-1:12 IEC 61010-2-201:2017 UL 61010-2-201:2017, C22.2 No. 61010-2-201:14
Measuring Relays and Protection Equipment:	IEC 60255-26:2013 IEC 60255-27:2013

Type Tests

Note: To ensure good EMI and EMC performance, type tests were performed using shielded Ethernet and serial cables with the shell grounded at both ends of the cable, and the USB, video, and audio cables with ferrite chokes. Double-shielded cables are recommended for best EMI and EMC performance.

Electromagnetic Compatibility Emissions

Conducted and Radiated Emissions:	CISPR 11:2009 + A1:2010 CISPR 22:2008 CISPR 32:2015 IEC 61000-6-4:2006 IEC 61850-3:2013 FCC 15.107:2014 FCC 15.109:2014 Severity Level: Class A Canada ICES-001 (A) / NMB-001 (A)
Harmonic Current:	IEC 61000-3-2:2014 Severity Level: Class A
Voltage Flicker:	IEC 61000-3-3:2013

Electromagnetic Compatibility Immunity

Conducted RF:	IEC 61000-4-6:2013 Severity Level: 10 Vrms
Electrostatic Discharge:	IEC 61000-4-2:2008 IEEE C37.90.3-2001 Severity Level: 2, 4, 6, 8 kV contact discharge; 2, 4, 8, 15 kV air discharge
Fast Transient/Burst:	IEC 61000-4-4:2012 Severity Level: Class A 4 kV, 5 kHz on power supply and outputs; 2 kV, 5 kHz on communications lines
Magnetic Field:	IEC 61000-4-8:2009 Severity Level: 1000 A/m for 3 s 100 A/m for 1 m
Power Supply:	IEC 61000-4-11:2004 IEC 61000-4-17:1999 + A1:2001 + A2:2008 IEC 61000-4-29:2000
Radiated Radio Frequency:	IEC 61000-4-3:2006 + A1:2007 Severity Level: 10 V/m IEEE C37.90.2-2004 Severity Level: 20 V/m

Surge Withstand Capability:

IEC 61000-4-18:2006 + A1:2010
Severity Level:
Power supply and outputs
2.5 kV peak common mode
1.0 kV peak differential mode
Communications ports
1.0 kV peak common mode
IEEE C37.90.1-2012
Severity Level:
2.5 kV oscillatory
4 kV fast transient

Surge Immunity:

IEC 61000-4-5:2005
1 kV line-to-line
2 kV line-to-earth
2 kV communications ports

Environmental

Change of Temperature:

IEC 60068-2-14:2009
Severity Level:
5 cycles, 1°C per minute ramp

SEL-3360S-2 With E3-1505L CPU:

–40°C to +75°C

SEL-3360S-2 With E3-1505M CPU:

–40°C to +60°C

SEL-3360E-2 With E3-1505L CPU:

–40°C to +60°C

Cold, Operational:

IEC 60068-2-1:2007
Severity Level: 16 hours at –40°C

Cold, Storage:

IEC 60068-2-1:2007
Severity Level: 16 hours at –40°C

Damp Heat, Cyclic:

IEC 60068-2-30:2005
Severity Level:
12 + 12-hour cycle
25° to 55°C, 6 cycles, >93% relative humidity

Damp Heat, Steady:

IEC 60068-2-78:2012
Severity Level:
40°C, 240 hours, >93% relative humidity

Dry Heat, Operational:

IEC 60255-1:2009
IEC 61850-3:2013
IEC 60068-2-2:2007
Severity Level:
SEL-3360S-2 With E3-1505L CPU: 16 hours at 75°C
SEL-3360S-2 With E3-1505M CPU: 16 hours at 60°C
SEL-3360E-2 With E3-1505L CPU: 16 hours at 60°C

Dry Heat, Storage:

IEC 60255-1:2009
IEC 61850-3:2013
IEC 60068-2-2:2007
Severity Level: 16 hours at 85°C

Free Fall:

IEEE 1613-2009
Severity Level: 100 mm

Vibration:

IEC 60255-21-1:1988
Severity Level:
Endurance Class 2
Response Class 2
IEC 60255-21-2:1988
Severity Level:
Shock Withstand, Bump Class 1
Shock Response Class 2
IEC 60255-21-3:1993
Severity Level:
Quake Response Class 2

Safety

Enclosure Protection:	IEC 60529:2001 + CRGD:2003 Severity Level: IP30
Dielectric Strength:	IEC 60255-27:2013 IEEE C37.90-2005 Severity Level: 3600 Vdc on power supply 2500 Vac on contact output 1500 Vac Ethernet ports Type tested for one minute
Impulse:	IEC 60255-27:2013 IEEE C37.90-2005 Severity Level: 5 kV common mode, power supply, contact outputs 1.5 kV Ethernet ports

Table 1 System Power Consumption (at 12 Vdc Input Voltage)

Power Consumption ^a			
Component	Minimum	Typical	Maximum
Base System (E3-1505L CPU, 4 GB RAM, 1 SATA Drive):	15 W	25 W	40 W
Additional Consumption From Optional Components			
SEL-9331 Power Supply (standard on SEL-3360E-2)	+10 W	+10 W	+10 W
E3-1505M CPU:	+2 W	+5 W	+13 W
8–64 GB RAM Configuration:	+2 W	+2 W	+3 W
2nd SATA Drive:	+1 W	+2 W	+3 W
SEL-3390E4 Ethernet Card	+6 W	+8 W	+10 W
SEL-3390S8 Serial or SEL-3390T Time Card, Each:	+4 W	+5 W	+7 W
Chipset Heater ^b			
cold startup (<5°C [41°F]):	N/A	N/A	+90 W
continuous operation (0°C [32°F]):	0 W	+5 W	+10 W
continuous operation (-40°C [-40°F]):	0 W	+20 W	+40 W

^a Minimum: 0% load on all components; minimum power consumption started and idle.
Typical: 25%-50% load on all components; good indication of most application loads.
Maximum: 100% load on all components; generally cannot be reached in normal applications.

^b Chipset heaters operate at low temperatures to keep the CPU and PCH within specified operating limits.

Table 2 Peripheral Connection Rated Current Output

Connection	Current Limit
DVI-D	0.2 A, +5 Vdc, 1 W total for both
DisplayPort	0.6 A, +3.3 Vdc, 2 W
COM 1 and COM 2	0.5 A, +5 Vdc, 2.5 W each
USB Ports	2.0 A, +5 Vdc, 10 W each, 25 W all ports combined

© 2018–2024 by Schweitzer Engineering Laboratories, Inc.

Content subject to change without notice.

Unless otherwise agreed in writing, all SEL product sales are subject to SEL's terms and conditions located here: <https://selinc.com/company/termsandconditions/>.

SCHWEITZER ENGINEERING LABORATORIES, INC.

2350 NE Hopkins Court • Pullman, WA 99163-5603 U.S.A.

Tel: +1.509.332.1890 • Fax: +1.509.332.7990

selinc.com • info@selinc.com

