



SEL-651RA Installation Instructions for 2-Pin Cable for Input Power

Introduction

This 2-pin cable for input power provides a two-pin male receptacle that exits from the bottom of the cabinet. The 2-pin cable for input power is internally wired to the control module's power supply terminals. Therefore, the 2-pin cable for input power also supplies power to the outlet and/or any other accessories effectively connected in parallel with the power supply terminals. The 2-pin receptacle provides a convenient means (by way of an external cable, which is not included) to connect input power to the control.

Parts

SEL Part Number	Description	Quantity
SEL-C2262	2-pin cable for input power	1
SEL-C5241	Ground wire	1
080-0101	5/8 steel wire clamp	2
140-0500	4-40 x 1/2" screw	4
140-0740	4-40 hex nut	4
144-0140	Plastic cap	1
310-0050	Zip ties	12

Installation

- Step 1. Install the 2-pin cable for input power in the bottom of the cabinet in the leftmost hole in the front row. Insert the receptacle from the inside of the cabinet and three of the four screws from the outside. Install the nuts on the screws from the inside of the cabinet. See *Figure 1*.
- Step 2. Install the smaller ring terminal of the green/yellow ground wire to the last connector screw and secure it with the last nut. See *Figure 1*.
- Step 3. Use the existing nut to connect the larger ring terminal of the green/yellow ground wire to the ground stud. See *Figure 1*.
- Step 4. If your unit is equipped with the fuse block for field wiring, go to *Wiring With Fuse Block*. Otherwise, go to *Wiring Without Fuse Block*.

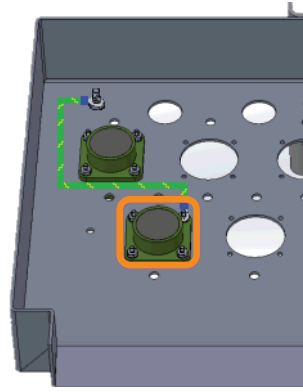

Figure 1 Install Ring Terminal

Wiring Without Fuse Block

Step 1. Form a drip loop and route the harness wires to the left toward the 14-pin connector. See *Figure 2*.

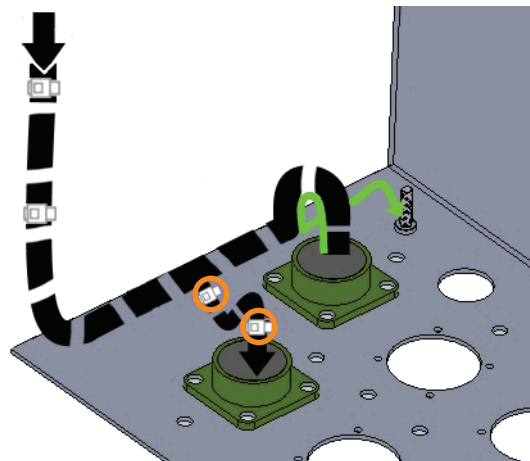

Figure 2 Form Drip Loop and Route Harness Wires

Step 2. Join the 2-pin wires with the main harness and route the wires through the wire loom and up the swing-panel hinge through the existing wire clamps.

Step 3. Route the wires across the top of the control module. The accessory wires route separately from the main harness.

Step 4. Use the existing nuts to secure the wires to the top of the control module with the two accessory wire clamps (if they are not already installed). See *Figure 3*.

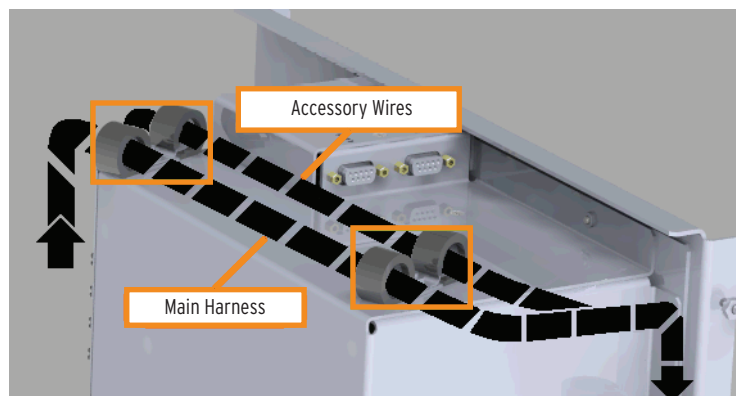
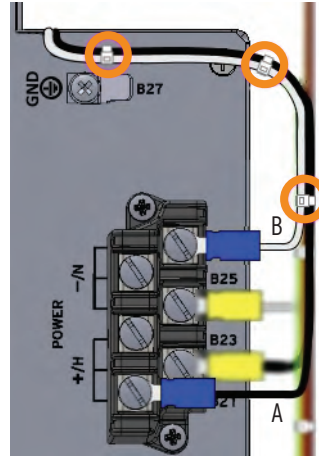

Figure 3 Secure Wires on Top of Control Module

- Step 5. Attach the white wire from the 2-pin cable to the B26 terminal on the control module and the black wire from the 2-pin cable to B21 on the control module. See *Figure 4*.



2-Pin Wires:	To:
A (Black Wire)	B21
B (White Wire)	B26

Figure 4 Attach Wires to Control Module

- Step 6. Zip tie wires as necessary.

Wiring With Fuse Block

- Step 1. Form a drip loop and route the harness wires to the bottom of the fuse block for field wiring. See *Figure 5*.

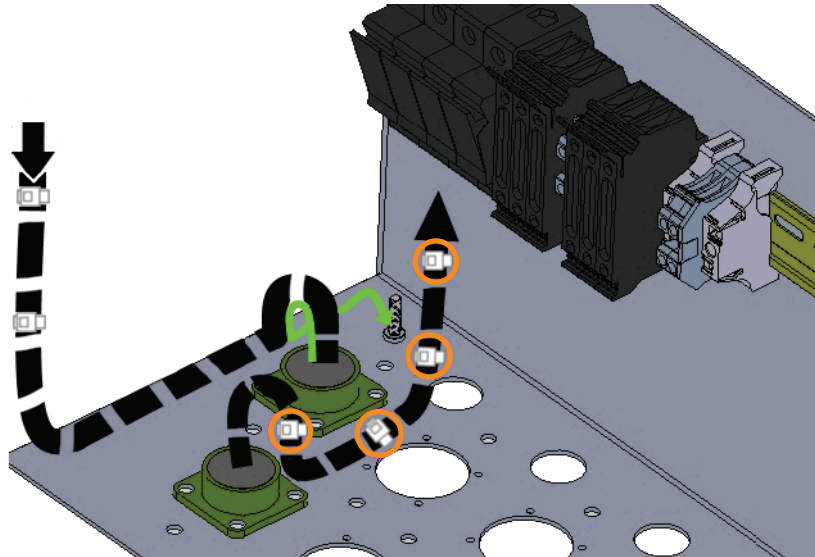
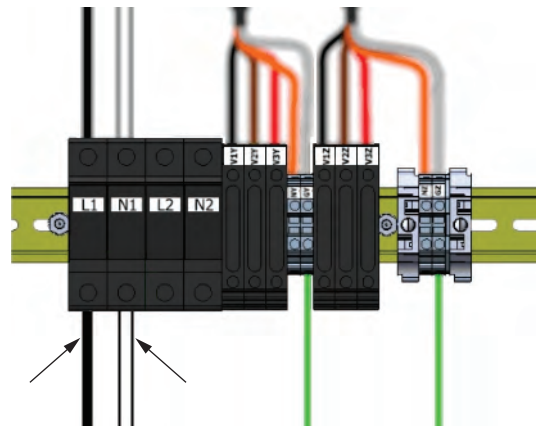

Figure 5 Route Harness Wires to Bottom of Fuse Block

- Step 2. Cut the cables to a reasonable length and strip the individual wires about 7/16 of an inch.
- Step 3. Attach the white wire from the 2-pin cable to the N1 fuse on the fuse block for field wiring and the black wire from the 2-pin cable to the L1 fuse on the fuse block for field wiring. See *Figure 6*.



2-Pin Wires:	To:
Black Wire (A)	L1
White Wire (B)	N1

Figure 6 Attach Wires to Fuse Block

Step 4. Zip tie wires as necessary.

Wiring Diagrams

Without Fuse Block

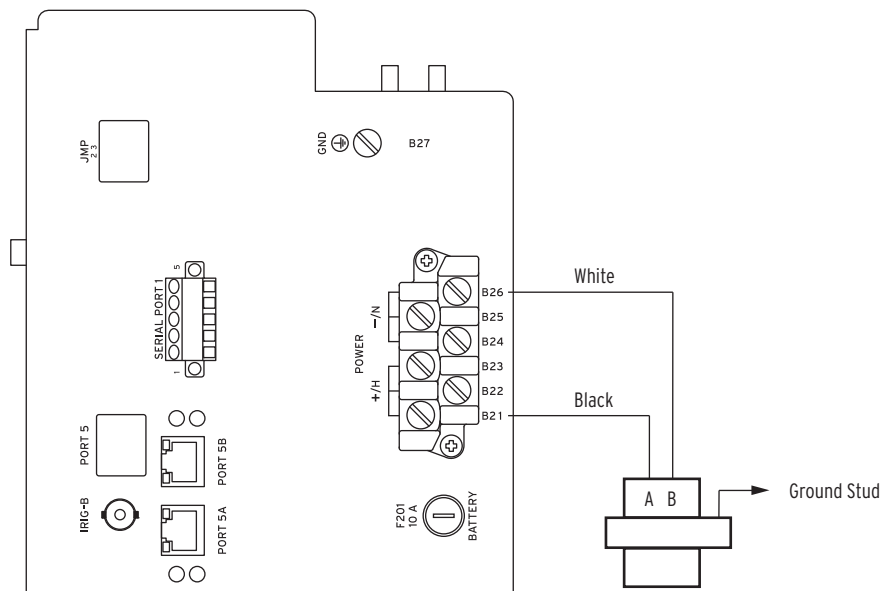

With Fuse Block

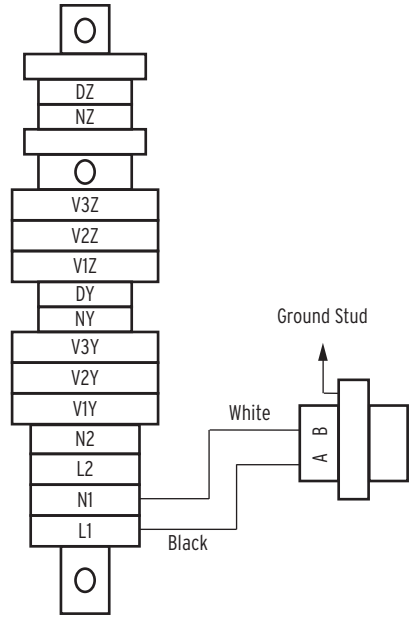
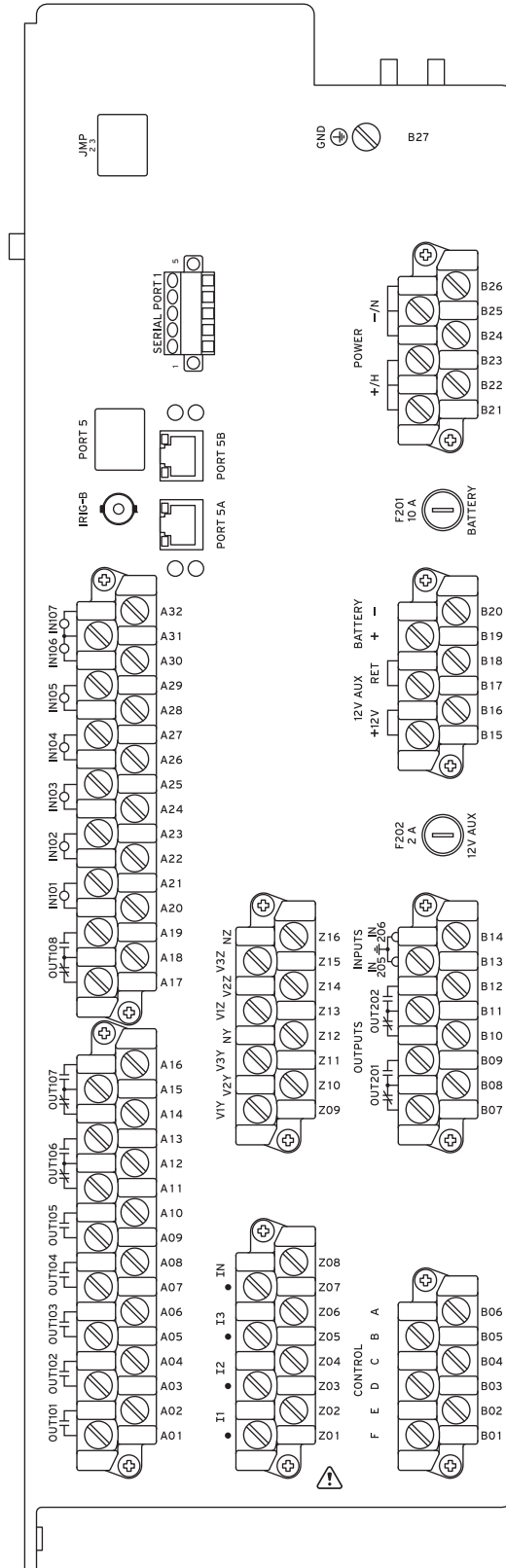

Wiring between fuse block and control module not shown.

Factory Assistance

We appreciate your interest in SEL products and services. If you have questions or comments, please contact us at:

Schweitzer Engineering Laboratories, Inc.
 2350 NE Hopkins Court
 Pullman, WA 99163-5603 U.S.A.
 Tel: +1.509.332.1890
 Fax: +1.509.332.7990
 Internet: selinc.com
 Email: info@selinc.com

WARNING

Operator safety may be impaired if the device is used in a manner not specified by SEL.

© 2016 by Schweitzer Engineering Laboratories, Inc. All rights reserved.

All brand or product names appearing in this document are the trademark or registered trademark of their respective holders. No SEL trademarks may be used without written permission. SEL products appearing in this document may be covered by U.S. and Foreign patents.

Schweitzer Engineering Laboratories, Inc. reserves all rights and benefits afforded under federal and international copyright and patent laws in its products, including without limitation software, firmware, and documentation.

The information in this document is provided for informational use only and is subject to change without notice. Schweitzer Engineering Laboratories, Inc. has approved only the English language document.

This product is covered by the standard SEL 10-year warranty. For warranty details, visit selinc.com or contact your customer service representative.

AVERTISSEMENT

La sécurité de l'opérateur peut être compromise si l'appareil est utilisé d'une façon non indiquée par SEL.

SCHWEITZER ENGINEERING LABORATORIES, INC.

2350 NE Hopkins Court • Pullman, WA 99163-5603 U.S.A.
 Tel: +1.509.332.1890 • Fax: +1.509.332.7990
 www.selinc.com • info@selinc.com

