

A Current Story – When Primary Met Secondary

Genardo Corpuz
Lower Colorado River Authority

Swagata Das and Ariana Hargrave
Schweitzer Engineering Laboratories, Inc.

© 2017 IEEE. Personal use of this material is permitted. Permission from IEEE must be obtained for all other uses, in any current or future media, including reprinting/republishing this material for advertising or promotional purposes, creating new collective works, for resale or redistribution to servers or lists, or reuse of any copyrighted component of this work in other works.

This paper was presented at the 70th Annual Conference for Protective Relay Engineers and can be accessed at: <https://doi.org/10.1109/CPRE.2017.8090007>.

For the complete history of this paper, refer to the next page.

Revised edition released May 2017

Previously presented at the
71st Annual Georgia Tech Protective Relaying Conference, May 2017,
70th Annual Conference for Protective Relay Engineers, April 2017,
and 52nd Annual Minnesota Power Systems Conference, November 2016

Previous revised edition released November 2016

Originally presented at the
43rd Annual Western Protective Relay Conference, October 2016

A Current Story – When Primary Met Secondary

Genardo Corpuz, *Lower Colorado River Authority*
Swagata Das and Ariana Hargrave, *Schweitzer Engineering Laboratories, Inc.*

Abstract—Protective relays require accurate voltage and current measurements from potential transformers (PTs) and current transformers (CTs) to reliably protect the power system. In this paper, we describe a unique event in which the secondary wiring of two CTs, one going to a bus differential relay and the other to a transformer differential relay, made contact with the primary system and caused a fault. This subjected both relays to primary-level currents, causing them to measure false differential current and operate. The paper discusses the outage that occurred and the investigation the utility performed, followed by how relay event reports were used to substantiate the utility’s findings and gain additional insight into the fault. The paper also discusses the damage that can occur to a relay when CT secondary wiring comes in contact with the primary system.

I. INTRODUCTION

In July of 2015, a 138 kV substation in Texas went dark for one hour and twenty-one minutes. The outage was caused by the bus differential relay tripping immediately after a transformer differential relay tripped in the substation. The utility investigated and found damage on one of the high-voltage bushings of the transformer. Their investigation further revealed that there was slack in both sets of current transformer (CT) secondary wires associated with that bushing, and they were not bundled together. One of those wires made contact with the bottom of the bushing and created a fault within the transformer relay’s zone of protection. The utility questioned why the bus differential relay operated for this seemingly external fault.

In this paper, we share details about this challenging fault and the root cause analysis. We then analyze the event reports captured by the relays to substantiate the initial findings and uncover the true sequence of events. This in-depth analysis identifies whether the bus CT or transformer CT wiring caused the fault, determines if the bus differential relay actually misoperated, and explains what can happen when a relay is subjected to primary-level currents.

This case study illustrates that understanding the physical construction of the equipment being protected is sometimes just as important as knowing how to set the relay that protects it. It also reinforces the importance of event analysis in gaining a better understanding of complex power system faults and determining their root cause. Finally, this case study reminds us that the power system is unforgiving and that something as simple as excess wire slack can result in a fault, cause an outage, and damage expensive equipment.

II. BACKGROUND INFORMATION

In order to follow the event analysis in this paper, it is important to understand the basics of percentage-restrained differential protection and transformer construction. Both of these topics are introduced in the following subsections and are documented in further detail in the references provided in Section IX.

A. Review of Percentage-Restrained Differential Protection

Current differential protection is a very selective form of protection based on Kirchhoff’s current law (KCL). Simply put, KCL states that the current entering the zone of protection must equal the current leaving the zone of protection, otherwise there must be another path (such as a fault) inside the zone for current to flow through. A current differential protection scheme is very selective and fast because its zone is determined by the location of the CTs, and no coordination with external devices is necessary. This type of scheme is commonly used to protect buses, transformers, and other important power system equipment.

In a percentage-restrained differential relay, CTs from both sides of the protected equipment are brought into the relay, and the measured currents (\vec{I}_1 and \vec{I}_2) are used to calculate operate (IOP) and restraint values (IRT), as shown in Fig. 1. The way these values are calculated can vary depending on relay design, but the operate quantity is a measure of difference current into the zone while the restraint quantity is a measure of through current through the zone. The operate and restraint values are calculated for each phase.

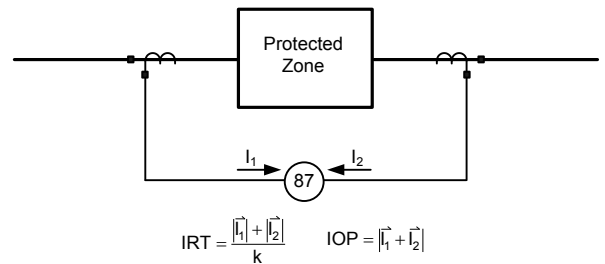

Fig. 1. Operate and restraint calculations for a percentage-restrained differential relay (factor k depends on the relay design)

The operate and restraint values are then used to plot a point on a percentage-restrained differential characteristic, as shown in Fig. 2. The percentage-restrained differential characteristic is made up of a minimum operate current and a slope value, which can be set in the relay. Relay designs can have single slopes, dual slopes, or adaptive slopes, but the idea behind them is the same. If the calculated operate and restraint values cause the point to fall above the line, then the relay operates. If the point falls below the line, the relay restrains. The operate current must always be greater than the minimum operate current setting in order for the relay to operate. There is also an unrestrained operate current setting, as indicated by the dotted line at the top of the graph in Fig. 2. If the relay calculates operate current above this pickup setting, it operates regardless of the restraint current.

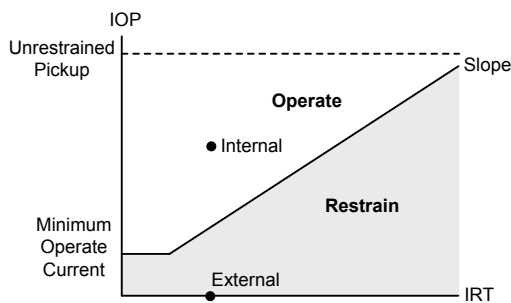

Fig. 2. Single-slope, percentage-restrained differential characteristic

The concept of current differential protection is simple when it comes to protecting buses where current in equals current out. An extra layer of complication is added when the same concept is used to protect a transformer. The turns ratio and winding connections of a transformer make it so that the current entering the transformer is not the same as the current leaving the transformer, even under normal conditions. External CT ratios and connections work alongside tap and angle compensation settings in relays to compensate for these differences. For more information on percentage-restrained differential protection for buses, refer to [1], [2], [3], and [4]. For more information on percentage-restrained differential protection applied to transformers, refer to [5] and [6].

B. Transformer Construction Overview

In order to properly understand this event, it is important to understand the basics of transformer construction. The transformer in this paper is a liquid-immersed, 138/13.09 kV, delta-wye transformer whose nameplate is shown in the appendix. A drawing of how this particular transformer is

constructed is shown in Fig. 3. The transformer tank houses and protects the magnetic core and winding assembly [7]. The tank is grounded to avoid injuries from static shocks or accidental connection of energized windings to the tank. The oil inside the transformer is a highly refined mineral oil that dissipates heat to the outside environment and provides insulation. This heat is generated by the core and by copper losses in the winding. The oil inside the tank is filled up to 12.1 inches from the topmost point of the transformer. The remaining space is filled with a layer of nitrogen gas (N_2) that protects the oil against air, moisture, and contamination. The operating pressure range of the liquid-filled system is 7.5 pounds positive to 0.5 pounds positive. A pressure relief device that consists of a frangible disk is mounted on top of the transformer tank. When violent pressures develop inside the tank during an internal fault that exceed the maximum operating pressure, the pressure inside the tank cracks the disk and oil vents out. This action relieves pressure inside the tank and prevents the tank from exploding and starting a fire.

Bushings are insulating structures that allow the transformer windings to safely connect to the electrical power system. The bushings on the high and low side of this particular transformer are of the oil and condenser type and are rated to withstand 88 kV and 16 kV, respectively. The primary conductor lands on the top terminal of the bushing. A hollow metallic central conductor tube extends from this terminal down to the bottom of the bushing. This tube is wrapped in insulating paper and conductive ink layers and is surrounded with high-grade transformer oil for insulation and heat dissipation. The bushing oil level can be viewed through the sight glass. Decreasing oil levels indicate a bushing that is leaking oil.

The exterior of the bushing consists of porcelain, which provides insulation and is skirted so as to increase the surface area distance between the grounded tank and the live phase conductor. The lower end shield is connected to the central conductor tube, making it at line potential. A flange is used to mount the bushing to the top of the transformer tank, with the lower end of the bushing immersed in the tank oil. The bushing in this case study is designed for a draw-lead application, meaning that the lead from the transformer winding (provided by the transformer manufacturer) is drawn through the hollow central tube of the bushing and connected to the top terminal. Draw-lead bushings are easy to replace and do not require the transformer oil to be lowered.

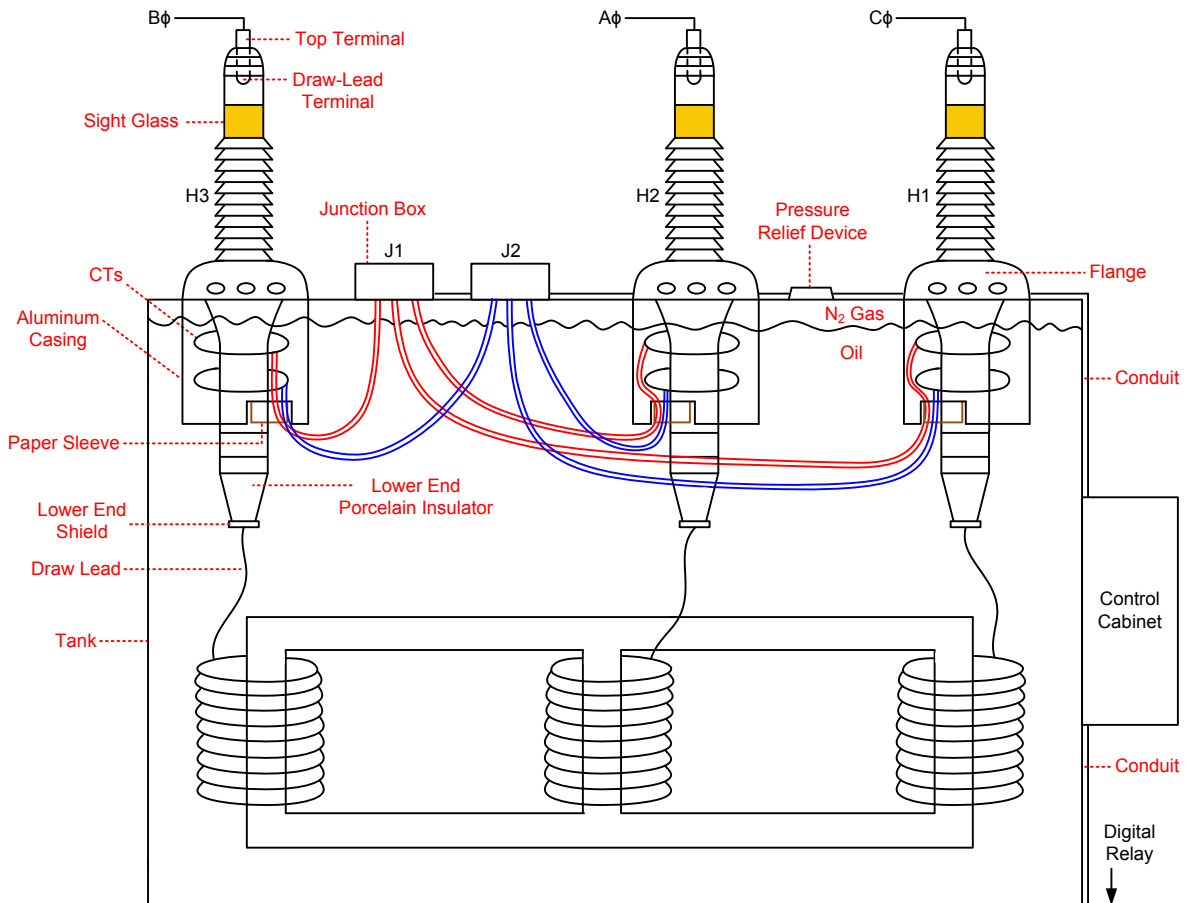

Fig. 3. Transformer construction

Two C800 protection-class CTs and one metering-class CT are installed around each bushing. The CTs are supported by an aluminum casing connected to the inside of the tank so that the bushing can be pulled out without disturbing the CTs. This aluminum casing is at ground potential. Note that Fig. 3 only shows the two protection-class CTs that are relevant in this case study. The CT secondary wiring comes out of the aluminum casing and runs through the oil in the tank to a junction box on top of the transformer. The CT wiring does not route through a conduit, but is instead held together in several places using nonconductive material such as ropes and paper sleeves. Fig. 4 shows the CT wiring inside the tank connecting to the underside of the CT junction box. This transformer has four junction boxes—two for the high-side CTs and two for the low-side CTs. Fig. 5 and Fig. 6 show that CT-1, CT-2, and CT-3 are routed to Junction Box 1; CT-5, CT-6, and CT-7 are routed to Junction Box 2; CT-21, CT-22, and CT-23 are routed to Junction Box 3; and CT-25, CT-26, and CT-27 are routed to Junction Box 4. Fig. 7 shows the inside of a junction box. From the junction box, the CT wiring is routed through a conduit to a control cabinet on the

side of the transformer. From the control cabinet, the CT wiring routes through an underground cable trench to protective relays in the control house.

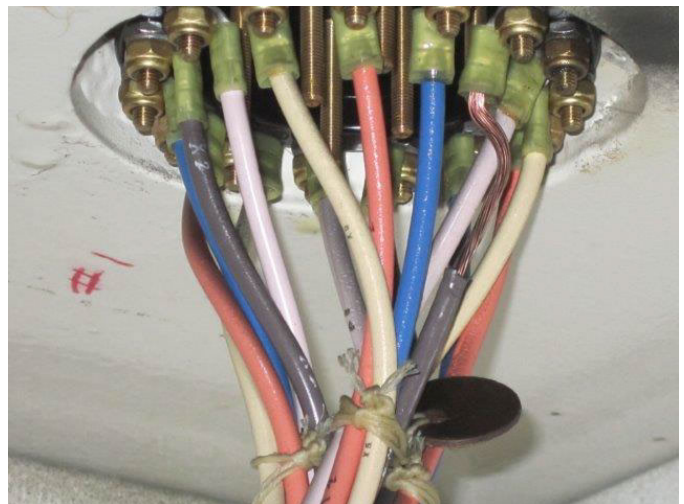

Fig. 4. CT secondary wiring inside the tank connected to the underside of a junction box

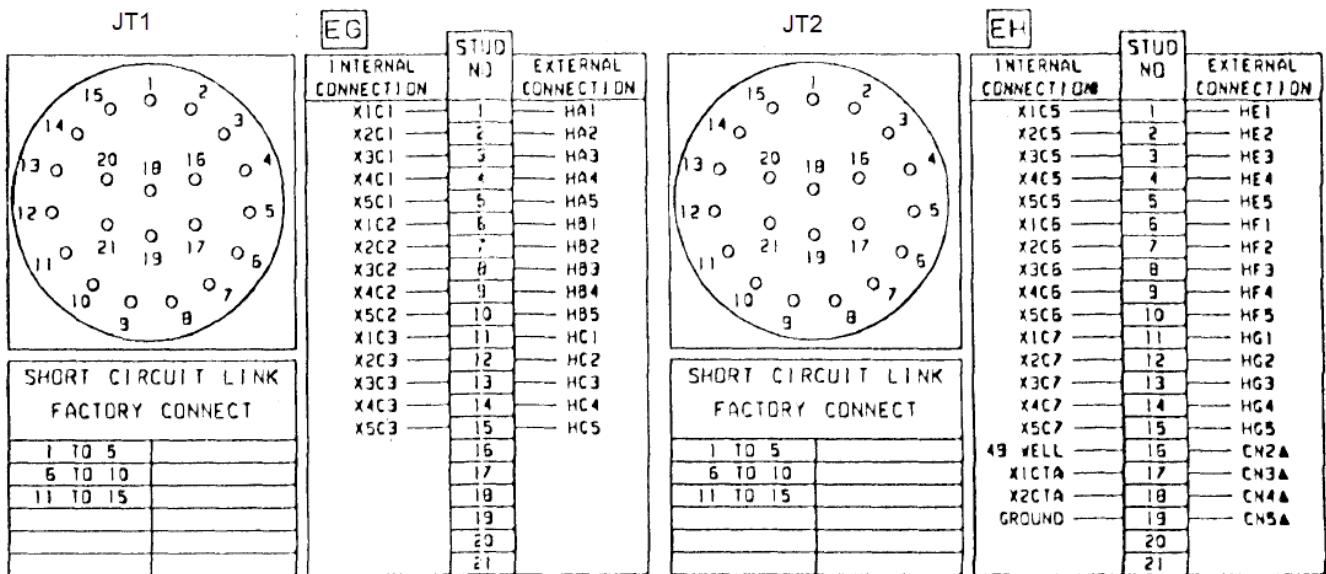

Fig. 5. High-side CTs: CT-1, CT-2, and CT-3 are routed to Junction Box 1 while CT-5, CT-6, and CT-7 are routed to Junction Box 2

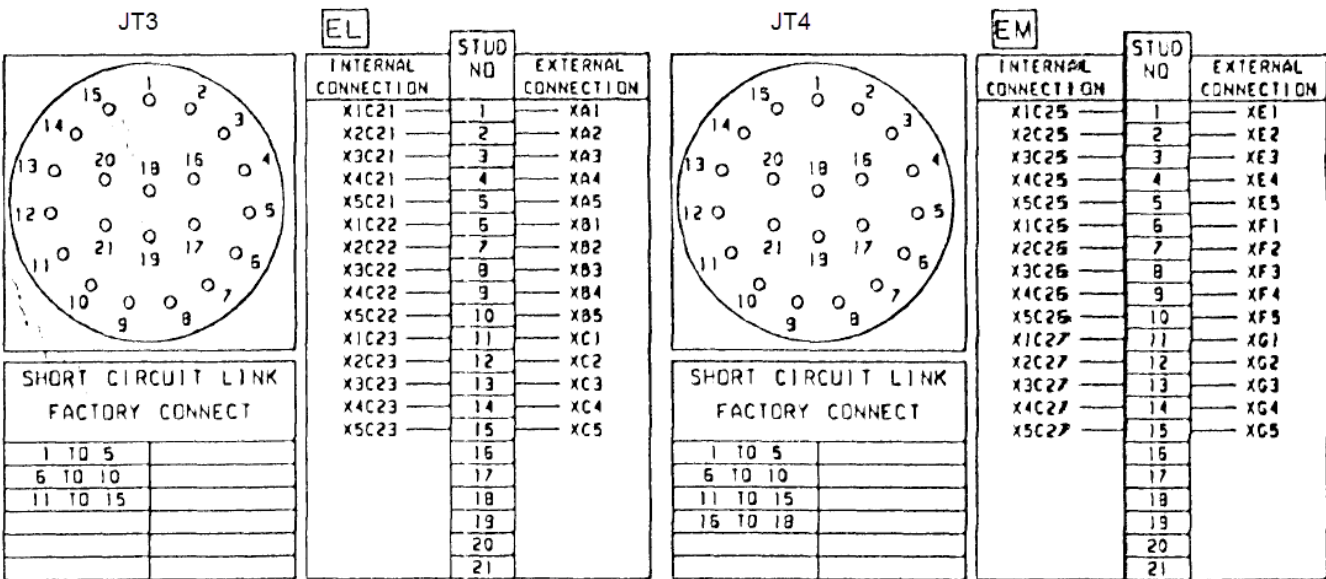

Fig. 6. Low-side CTs: CT-21, CT-22, and CT-23 are routed to Junction Box 3 while CT-25, CT-26, and CT-27 are routed to Junction Box 4

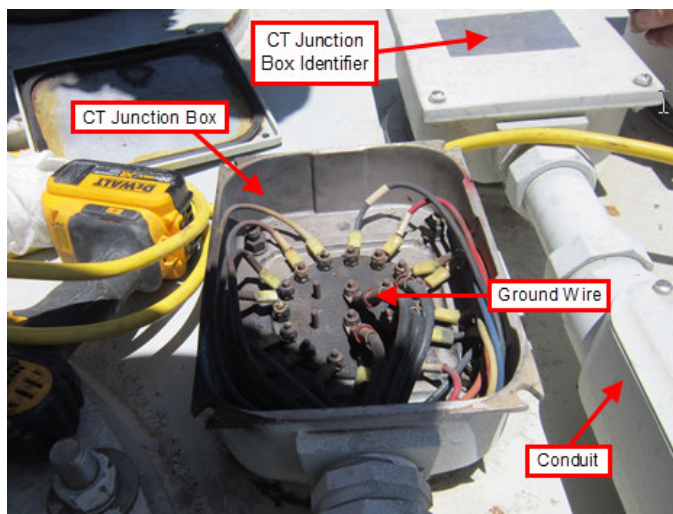

Fig. 7. CT junction boxes on top of the transformer

The transformer has nonstandard phase-to-bushing connections. The system C-phase is connected to Bushing H1, the system A-phase is connected to Bushing H2, and the system B-phase is connected to Bushing H3. Table I summarizes the phase current measured by each CT and its location, as well as the junction box and the relay to which each CT secondary is wired. Relay Y is a transformer differential relay that protects the transformer, Relay Z is a backup overcurrent relay for the transformer, and Relay X is a bus differential relay (explained further in Section III).

TABLE I
CT CONNECTIONS TO THE JUNCTION BOX AND RELAYS

CT ID	Location	Junction Box	Relay
CT-1	Transformer high side H1 bushing/C-phase	Junction Box 1	Transformer Relays Y and Z
CT-2	Transformer high side H2 bushing/A-phase		
CT-3	Transformer high side H3 bushing/B-phase		
CT-5	Transformer high side H1 bushing/C-phase	Junction Box 2	Bus Relay X
CT-6	Transformer high side H2 bushing/A-phase		
CT-7	Transformer high side H3 bushing/B-phase		
CT-21	Transformer low side X1 bushing/C-phase	Junction Box 3	Transformer Relay Y
CT-22	Transformer low side X2 bushing/A-phase		
CT-23	Transformer low side X3 bushing/B-phase		
CT-25	Transformer low side X1 bushing/C-phase	Junction Box 4	Relay belonging to another utility (not relevant for this event)
CT-26	Transformer low side X2 bushing/A-phase		
CT-27	Transformer low side X3 bushing/B-phase		

III. THE OUTAGE

Fig. 8 shows a simplified one-line diagram of the 138 kV utility substation. Primary and backup distance relaying (Relays R, S, T, and U) protects the incoming transmission lines. The 138 kV bus is protected by a four-winding, percentage-restrained bus differential relay (Relay X) backed up by remote transmission line relays. Dual bus differential

protection is only applied on 345 kV substations and above per the utility's standard.

Two 12/16/20 MVA, 138/13.09 kV step-down transformers connect to the 13.09 kV distribution system. Switch SW3 is normally open and serves to switch loads between the two transformers. The first step-down transformer (T1) is protected by a transformer differential relay (Relay Y) and a backup overcurrent and breaker failure relay (Relay Z). The backup overcurrent and breaker failure relay shares the high-side transformer CTs with the transformer differential relay. The second step-down transformer (T2) is also protected by a transformer differential relay (Relay W) and a backup overcurrent and breaker failure relay (Relay V), but each relay has its own independent sets of CTs.

On July 13, 2015, at 8:39 p.m., the transformer differential relay protecting Transformer T1 tripped and operated the transformer lockout. The transformer lockout tripped and locked out Circuit Switcher CS1. 3.28 cycles after the transformer relay issued a trip, the bus differential relay tripped and operated the bus lockout, de-energizing the entire substation. The bus lockout tripped, locked out, and blocked reclosing on Circuit Breakers CB1 and CB2, and Circuit Switchers CS1 and CS2. After a three-minute outage, the utility remotely reset the lockout and the bus differential relay and tested the bus by closing CB2 through supervisory control and data acquisition (SCADA). When the close was successful, SCADA also remotely closed CB1. Maintenance personnel were dispatched to the substation and arrived 25 minutes later, reporting oil on the ground near Transformer T1. They also confirmed that they had opened the low-side switch (SW1) of Transformer T2 and that Transformer T2 was ready to be energized. At this point, SCADA closed CS2 in order to energize Transformer T2. Switches SW1 and SW3 were closed and all load was restored to Transformer T2. Transformer T1 was tagged for investigation. The entire outage lasted an hour and twenty-one minutes.

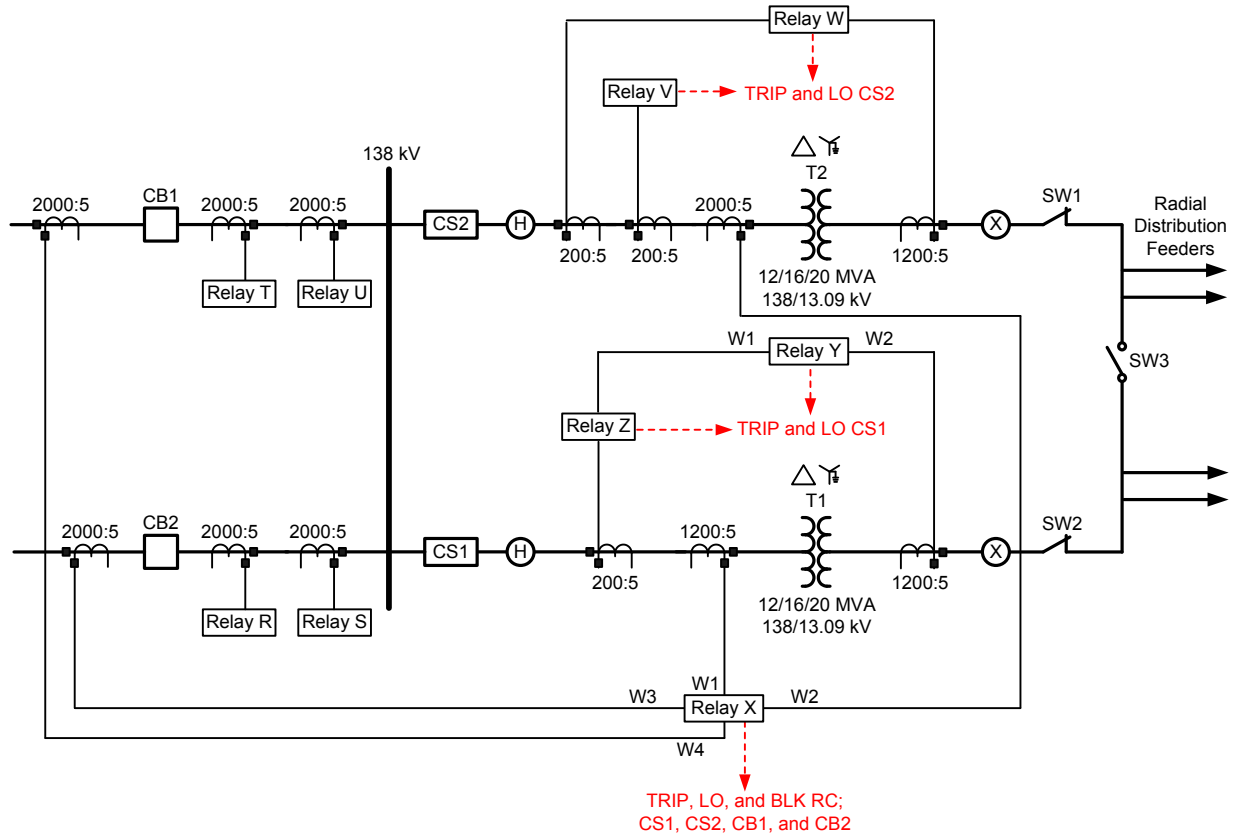

Fig. 8. Simplified one-line diagram

IV. UTILITY INVESTIGATION

IEEE C57.125 [8] is an excellent resource when investigating a transformer failure or when routine tests show deviation from past maintenance reports. The utility in this case study has its own standard on procedures to be followed after a transformer trip, which includes many of the diagnostic tests recommended by IEEE. This section describes the failure investigation and diagnostic tests the utility conducted to identify the root cause of the transformer failure.

A. Visual Inspection

Immediately after the fault, when maintenance personnel arrived on site, they visually inspected the transformer from the outside and noticed that the high-side H3 bushing was cracked. They also noticed that the mechanical pressure relief device had cracked and allowed oil to vent out of the transformer and onto the ground. Targets on the front of the transformer differential relay (Relay Y) indicated a B-phase-to-C-phase fault. The fact that both the bus and transformer relays operated, along with the damage found on the H3 bushing, led to the initial thought of a high-side bushing failure where the zones of protection overlap.

B. Gas Analysis

The next day, maintenance personnel performed a total combustible gas (TCG) analysis on a sample of gas drawn from the gas space above the oil. TCG analysis is a quick and valuable testing tool for determining the condition of a transformer. Oil-filled transformers typically generate a small

amount of combustible gases under normal operating conditions because the insulation of an oil-filled transformer deteriorates with age and operation. However, a sudden increase in TCG levels indicates that the transformer insulation was exposed to very high temperatures and warrants additional action. TCG levels were found to be significant, about 37 percent. Reference [9] recommends removing the transformer from service and contacting the transformer manufacturer when TCG levels are greater than 5 percent.

The high levels of TCG prompted the utility to perform a dissolved gas analysis test, which identifies the key gases and helps determine the type of fault. Diagnostic crews were called to draw an oil sample and perform onsite testing. Tests revealed 892 ppm of acetylene and 519 ppm of ethylene. High levels of acetylene indicate high-temperature arcing, and high levels of ethylene indicate severe oil overheating [9].

C. Electrical Tests

Armed with the knowledge that there was indeed a fault inside the transformer, maintenance personnel performed several electrical tests to isolate the root cause of the fault. The tests provided insight into the internal conditions within the transformer without actually opening it up. The tests performed, as well as the results, are as follows:

1) Turns Ratio Test (Pass)

A turns ratio test indicates if there are any shorted turns, winding damage, or problems in the core. A known voltage is applied on the high-voltage winding and the induced voltage

is measured on the corresponding low-voltage winding. A voltage ratio is calculated between the high-side applied voltage and the low-side measured voltage. The calculated ratio must be within 0.5 percent of the nameplate voltage ratio in a healthy transformer.

2) Leakage Impedance Test (Pass)

Leakage reactance or the short-circuit impedance of a power transformer can be used to detect winding deformation. Two types of tests were performed by the utility: a three-phase equivalent test and a per-phase test. In all tests, the measured leakage impedance was within 3 percent of the transformer nameplate values.

3) Bushing Power Factor Test (Fail)

A power factor test on a bushing measures the loss angle of its insulation. Under ideal conditions, the bushing insulation is a pure capacitor—a test current leads the test voltage by an angle of 90 degrees, resulting in a power factor of zero. However, some natural resistance in the material causes the bushing to have a nonzero power factor that is typically given on the bushing nameplate. If the measured power factor shows a sudden deviation from the nameplate values or past tests, then that is a cause for concern. In this case, the power factor of the H2 bushing was more than double its nameplate value and was therefore tagged for further investigation. All other high-side and low-side bushings tested normal.

After the test, a visual inspection of the bushings was performed. Although the low-side bushings had tested normal, a black stain was visible through the sight glass on the X1 and X3 bushings, as shown in Fig. 9.



Fig. 9. Black stain buildup observed through the sight glass of the X3 bushing

4) Excitation Test (Pass)

An excitation test detects shorted turns, loose electrical connections, tap changer problems, and other core and winding problems [10] [11]. The principle of this test is based on the fact that the excitation current drawn by the transformer to magnetize its core increases if there is a fault on the secondary winding. If the transformer is healthy, the excitation current pattern must match prior tests. For a three-legged transformer, the current pattern is typically two high currents and one low current. Furthermore, the difference between the two higher currents must be less than 10 percent in a healthy transformer, and it was in this case.

5) Sweep Frequency Test (Pass)

A sweep frequency test assesses the mechanical integrity of the transformer and detects core and winding problems [10]. The test is based on the premise that a transformer winding is nothing but a complex network of distributed resistance, inductance, and capacitance. The resistive-inductive-capacitive (RLC) network produces different output voltages at different frequencies that act as a unique signature. Any deviation of this signature from baseline tests conducted at the factory, during commissioning, or during a regular maintenance cycle provides a strong indication of a problem with the core or the winding. In this event, the sweep frequency test conducted by the utility in 2012 as part of its routine maintenance served as the baseline case and is shown in Fig. 10a. The sweep frequency test conducted after the transformer trip is shown in Fig. 10b. Both traces match and no problem was found.

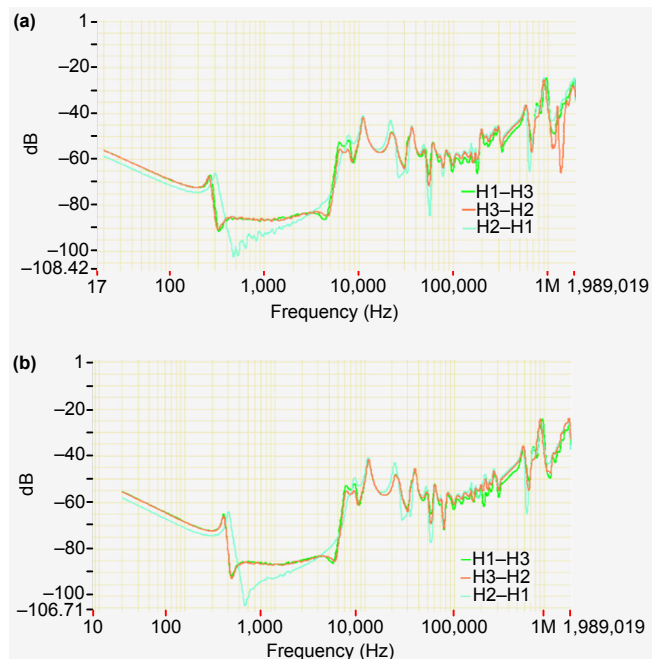

Fig. 10. Sweep frequency test performed during a maintenance test in 2012 (a) and after the fault in 2015 (b)

D. Summary of Preliminary Investigation

In summary, the initial visual inspection found damage on the H3 bushing. The gas analysis tests showed evidence of arcing and severe overheating inside the transformer tank. A variety of electrical tests were performed to gain insight into the root cause of the arcing without opening up the transformer tank. These tests found no evidence of short circuits in the transformer winding or damage to the core, but they did detect a problem with the H2 bushing. Because visual inspection and electrical tests both pointed to a high-side bushing problem (but on different bushings), the utility was confident that the preliminary investigation backed up their initial hypothesis of a high-side bushing failure. They then decided to drain oil from the transformer and perform an internal inspection.

E. Internal Inspection

Although the electrical tests described in Subsection C indicated a problem with the H2 bushing, internal inspection found no visible damage on that bushing. Internal inspection did, however, find significant damage on the H3 bushing. In addition to the damage on the H3 bushing, there was also significant damage to the CT secondary wiring associated with that bushing. Three of the CT wires were damaged, broken, and had bare wire exposed, as shown in Fig. 11. The coloring of the wires is no longer visible due to the carbon coating from the fault. It was also noted that the CT wires associated with the H3 bushing had more slack than the CT wires associated with other bushings and were not bundled together. The bottom of the H3 bushing, which showed pitting and carbon deposits from an arc on the lower end shield, is shown in Fig. 12.

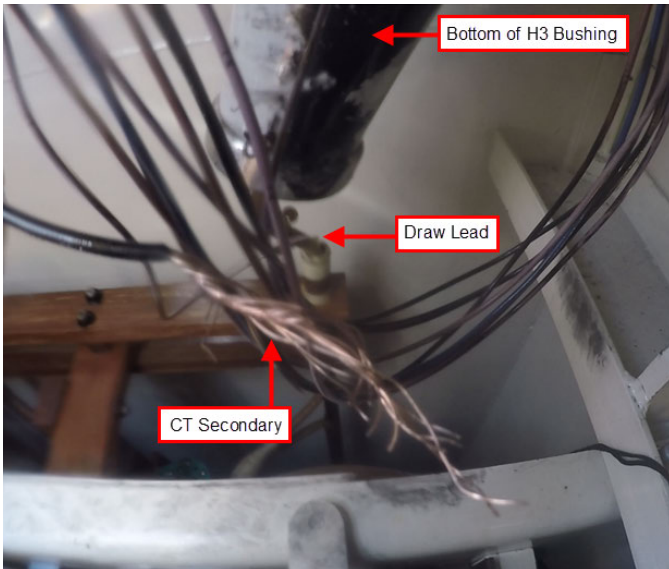

Fig. 11. Broken CT wiring and damaged H3 bushing

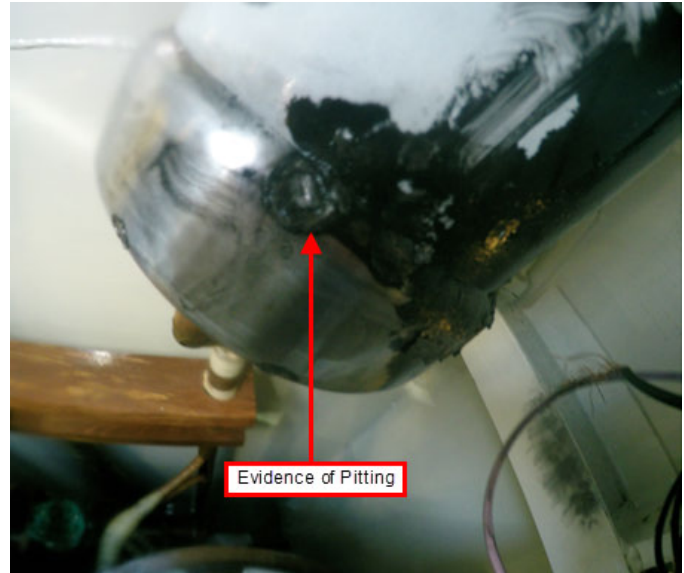

Fig. 12. Close-up view of the pitting observed in the bottom of the H3 bushing

Physical damage was clearly evident on the H3 bushing, so why did the H2 bushing fail the power factor test while the H3 bushing passed? It is important to understand that a lower power factor measurement does not necessarily mean that the bushing experienced a fault and could simply be a result of regular deterioration. In the case of the H3 bushing, the fault was located at the lower end shield and did not affect the insulation or the results of the power factor test.

The utility reported that extensive cleaning would need to be completed before the transformer could go back in service. Fig. 13 shows a line of carbon at the top of the tank, where carbon was floating on the surface of the oil. There was also some carbon sediment sitting on the core and at the bottom of the tank. Although the bushing itself is removed, Fig. 13 still shows the metal casing that holds the CTs at the top of the tank, along with the paper sleeves where the CT wiring is routed out and away from the bushing.

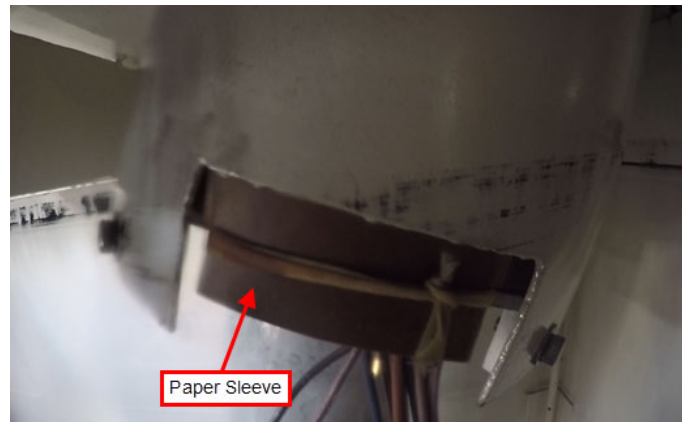

Fig. 13. Carbon at the top of the transformer tank

Evidence of arcing and insulation punctures was found in the CT secondary wiring going toward the junction box, as shown in Fig. 14. High-side CT Junction Box J1 was completely burned, as shown in Fig. 15. CT wiring from this box is routed to the current inputs of the transformer differential relay (Relay Y) and the backup overcurrent relay (Relay Z). The other three junction boxes were not damaged.



Fig. 14. Arcing to the tank and punctures on CT secondary insulation



Fig. 15. Damage to high-side Junction Box 1

It was theorized that the excess slack in the CT wiring allowed the wires to fall low enough to make contact with the lower end shield at the bottom of the H3 bushing (see Fig. 16). Because the lower end shield is at line potential (80 kV) and the insulation of the CT secondary wiring is rated for only 600 V, a catastrophic insulation failure occurred when the CT secondary insulation made contact with the lower end shield. The insulation failure subjected the secondary CT wiring, along with the CT junction box, to primary-level voltage and caused an arc to ground at the junction box.

The internal inspection described previously led to additional questions. What caused this excess slack in the CT secondary wiring? Why was the wiring not bundled? Initially, the utility thought that the CT secondary wiring could have been moved if a bushing had been replaced, but their records showed that no such maintenance had been done. Therefore, the utility concluded that the lack of bundling and excess slack must have been a manufacturing defect. However, the transformer had been in service since 1994. If this was indeed a manufacturing defect, why didn't this fault occur sooner? What changed between 1994 and 2015?

It is possible that the oil circulating in the transformer tank moved the secondary wires over time until the wires eventually made contact with the bottom of the bushing. Through faults also cause movement inside of a transformer and may have been responsible for moving the wires. In addition, fans are used to cool the transformer and a pump is used to circulate oil in the tank. It is possible that either of these devices turning on or off could have jostled the transformer enough to displace the secondary wiring. However, without data showing when the pump and fans were in operation, the exact cause could not be identified.

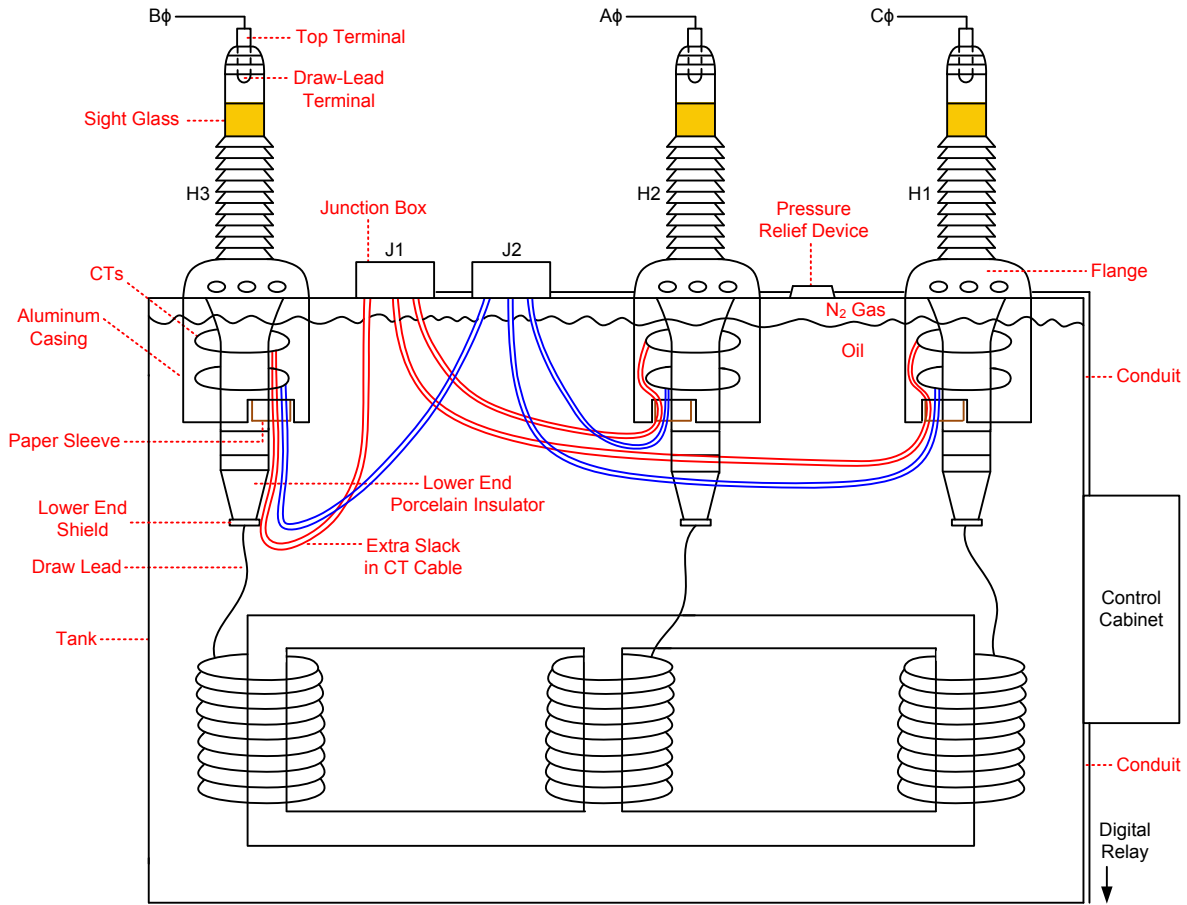

Fig. 16. CT secondary associated with the H3 bushing has excess slack and was not bundled

V. EVENT REPORT ANALYSIS

While the utility began the process of repairing the transformer, they also gathered event reports from the relays involved and began to analyze the fault. The utility requested assistance from the relay manufacturer in determining if the event reports from the relays validated their findings. In addition, the utility was concerned that both the bus and transformer relays operated. Looking at the CT placement and zones of protection in Fig. 17, a fault on the bottom of the bushing would be external to the bus relay’s zone of protection. In this case, shouldn’t the transformer relay have been the only one to operate?

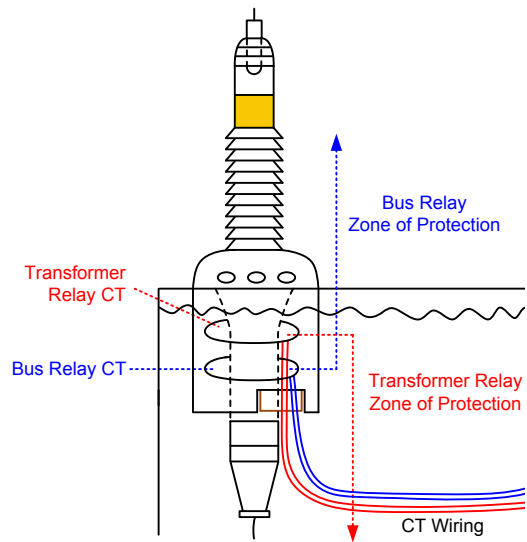

Fig. 17. CT placement and zones of protection

A. Transformer Relay Event Report (Relay Y)

Fig. 18 shows the filtered event report from the transformer differential relay (Relay Y) protecting Transformer T1. The blue vertical line shows when the relay issued a trip on the unrestrained differential element (87U). The event shows that fault current is very high on the high side of the transformer (IAW1, IBW1, and ICW1), with not much change to the currents on the low side (IAW2, IBW2, and ICW2). Because fault current did not pass through the low-side CTs, it can be concluded that the fault was upstream of those CTs.

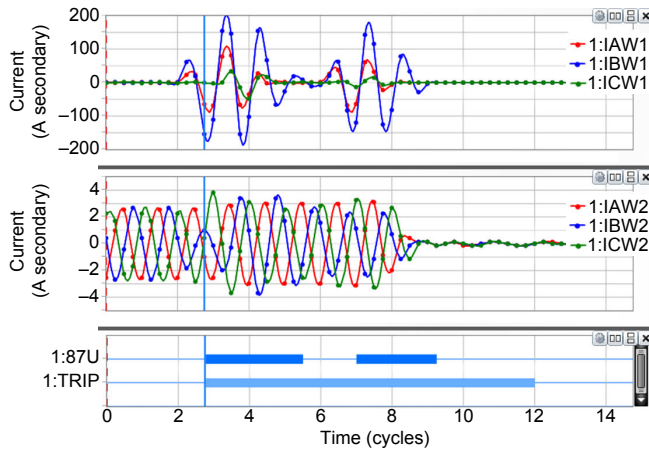

Fig. 18. Filtered currents on high and low side reported by transformer relay

Fig. 19 shows the operate and restraint currents recorded by the transformer relay in per unit (pu) of tap. IOP1_PU and IRT1_PU correspond to the A-phase operate and restraint currents that the relay calculates after it has compensated IAW1 and IAW2 (in Fig. 18) by magnitude and phase angle, as described in Section I. Similarly, IOP2_PU and IRT2_PU correspond to the B-phase and IOP3_PU and IRT3_PU correspond to the C-phase operate and restraint currents. Note that when the fault starts to occur at Cycle 2, both the operate and restraint currents increase. The B-phase and C-phase operate currents soon become higher than the unrestrained element pickup value (U87P) of 8 pu. Unrestrained elements 87U2 and 87U3 assert, and the relay operates. The transformer relay tripped correctly for the increase in operate current that it saw from the fault.

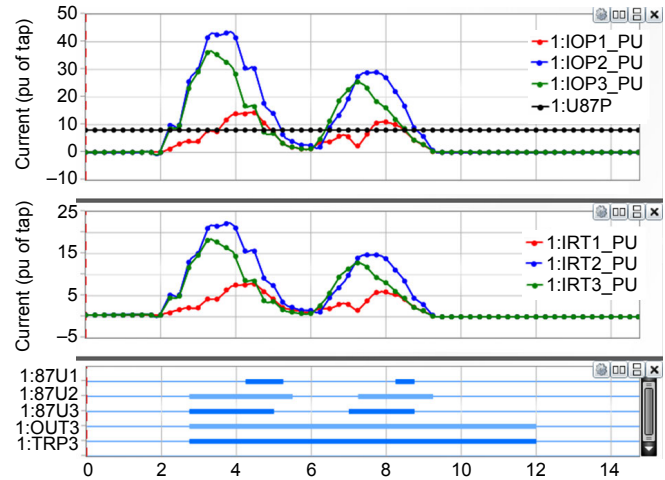

Fig. 19. Operate and restraint quantities from the transformer relay

The event reports in Fig. 18 and Fig. 19 are filtered events, meaning that the currents shown have already been filtered by the relay and have had all harmonics and dc offset removed in order to create a 60 Hz phasor. Filtered event reports are useful for analyzing relay operation, but a raw event report is needed to determine what signals the relay actually saw from the CTs before filtering was applied. In this case, we know that CT wiring caused the fault, so it is important to look at the raw data. Although a raw event report from the transformer relay was not collected, one was obtained from the backup overcurrent and breaker failure relay (Relay Z) that was connected to the same set of high-side CTs as Relay Y. This event report is shown in Fig. 20.

The event report shows that B-phase current (IBY_SEC) spiked first, followed shortly thereafter by A-phase current (IAY_SEC), and then the C-phase current (ICY_SEC) a cycle later. This corresponds to the transformer high-side B-phase CT, located on the H3 bushing, making contact with the primary system first. The fault then quickly propagated to the A-phase and C-phase CTs. Because all CT secondary wiring is routed together from the CTs to the junction box, it makes sense that a fault involving one lead would quickly propagate to the others nearby. Recall that the high-side CTs connected to the transformer relay were routed though Junction Box 1, which is the box that was severely burned after the fault.

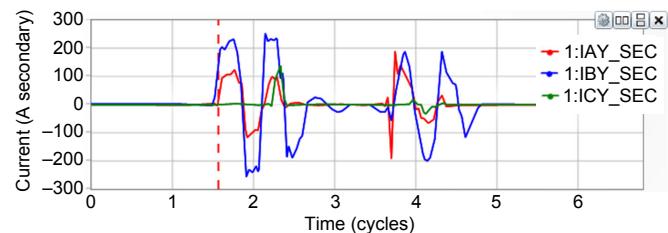

Fig. 20. Raw currents on high side of transformer

Note in Fig. 20 that the peaks of the B-phase waveform are flat. The analog-to-digital (A/D) converter of the relay in Fig. 20 is rated for a maximum peak value of 230 A secondary. When the A/D converter is exposed to current above this limit, it reports its maximum value (230 A), resulting in a waveform that looks clipped. This means that the event report cannot tell us the maximum current that the relay actually saw, but we do know that it had to be higher than 230 A. Recall that the values in the raw event report are the same values that were filtered and reported in the filtered event report in Fig. 18, so the magnitudes and angles in Fig. 18 are also affected.

It is important to note that while the transformer relay did operate correctly for this fault, the fact that the relay saw the fault as internal to its zone of protection cannot be guaranteed every time. For normal power system faults, CT signals and polarities can be used to reliably determine if the fault is internal or external to the zone of protection. In the case that CT wiring itself is involved in the fault, the signals the relay receives do not reliably represent what is going on in the power system, and proper operation cannot be guaranteed.

The transformer relay event report validates the utility's findings based on physical inspection. It does not, however, reveal whether the transformer CT was the first or only CT to make contact with the bottom of the bushing. Remember from Section 1, Subsection B that there are two protection-class CTs around each bushing—one that brings current to the transformer relay and another that brings current to the bus relay. It is possible that the bus relay CT wiring was also involved in the fault, resulting in the bus relay operating for an out-of-zone fault. To confirm this theory, we looked at the bus relay event report. This analysis is described in the following subsection.

B. Bus Relay Event Report (Relay X)

Fig. 21 shows the filtered event report from the low-impedance bus differential relay (Relay X). The dashed red vertical line shows when the relay issued a trip on the unrestrained differential element (87U). The W2 input on the bus relay (corresponding to the high side of Transformer T2) is not shown because it was not a source of fault current throughout the event.

Fault current begins to flow at Cycle 1 of the event. Between Cycle 1 and Cycle 3, B-phase fault current was seen on the W3 and W4 inputs of the relay (corresponding to the incoming transmission lines) as well as the W1 input (corresponding to the high side of Transformer T1). For a true external fault, the currents coming into the zone of protection

should equal the currents leaving the zone of protection. Fig. 22 shows the B-phase current phasors in primary amperes for W1, W3, and W4 at Cycle 3 of the event. The phasors show that the two incoming feeds (W3 and W4) have the same phase angle, and their sum is equal to and 180 degrees out of phase with the outgoing feed (W1). This is what is expected for an external fault.

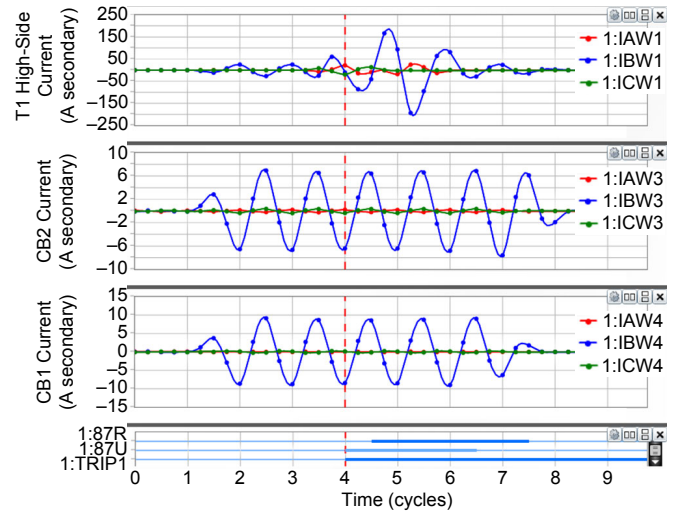

Fig. 21. Filtered currents reported by the bus relay

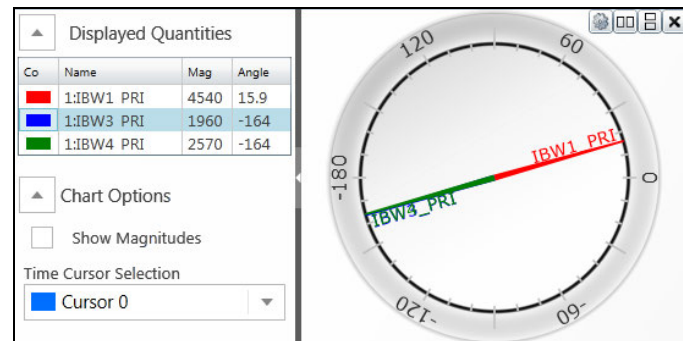

Fig. 22. B-phase current phasors in amperes primary reported by the bus relay at Cycle 3

This part of the event can be related to what was going on physically inside of the transformer at the time. This external fault corresponds to the transformer relay CT secondary wiring making initial contact with the primary system. The bus differential relay correctly identified the fault to be outside of its zone of protection and remained secure during these first 3 cycles.

At Cycle 4, the bus relay operated on unrestrained differential. Fig. 20 shows that between Cycles 3 and 4, there is a change in B-phase current on the W1 input (corresponding to the high side of Transformer T1). Fig. 23 shows the B-phase current phasors at Cycle 4 of the event. Note that W3 and W4 still have the same magnitude and phase angle, but because the W1 input changed, their sum is no longer equal to and 180 degrees out of phase with W1. Note also the dramatic increase in W1 current. Because the system is radial, the magnitude of W1 can never be greater than the summation of the W3 and W4 currents for a fault on the system. The fact that this occurred leads us to conclude that the relay could not have been receiving reliable signals, and the CT secondary wiring of the bus relay W1 CT also became involved in the fault.

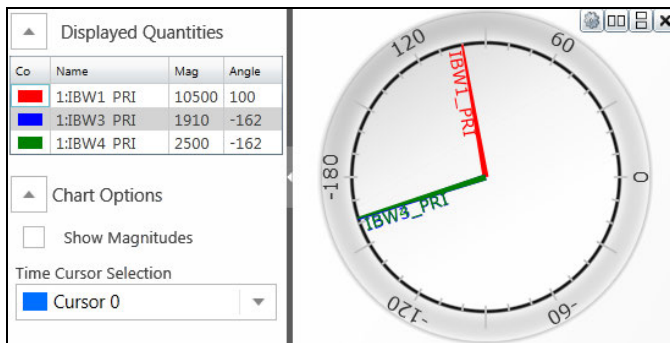

Fig. 23. B-phase current phasors in amperes primary reported by the bus relay at Cycle 4

The raw event report from the bus relay, shown in Fig. 24, confirms our theory. For the first couple of cycles, the bus relay sees an external fault and restrains. Then, around Cycle 5, the external CT wiring fault evolved to include the B-phase bus relay CT. A/D clipping occurs on this relay as soon as the amplitude reaches a peak of 225 A secondary. Note that the time axes on raw and filtered event reports cannot be directly compared because of the delay caused by the internal relay filters that produce the filtered event report.

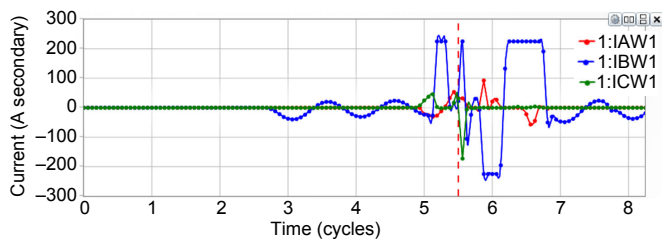

Fig. 24. Raw currents on W1 (corresponding to high side of Transformer T1) reported by the bus relay

Fig. 25 shows the operate and restraint currents during the event in pu of tap. Note that when the fault starts to occur at Cycle 1, the B-phase restraint current (IRT2) increases, but there is no increase in the B-phase operate current (IOP2). This keeps the relay secure for the external fault. At Cycle 3.5, the fault starts to evolve and the operate current increases dramatically. At Cycle 4, the operate current becomes higher than the unrestrained element pickup value (U87P) of 10 pu, and the relay operates.

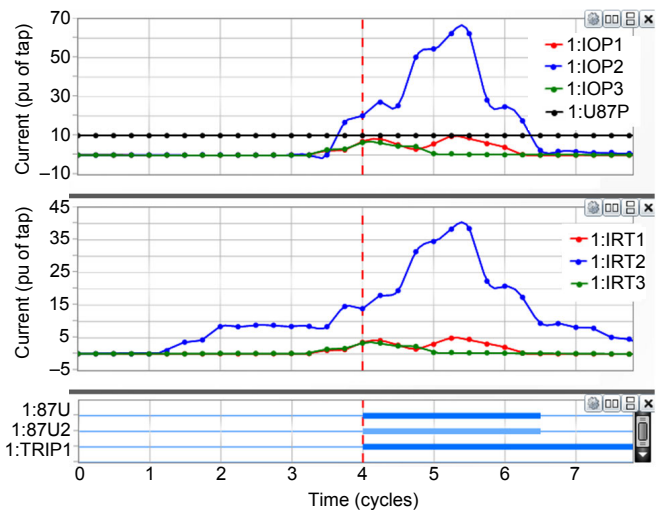

Fig. 25. Operate and restraint quantities from the bus relay

Although the point where the CT wiring made contact with the bottom of the bushing was physically outside of the bus relay zone of protection (per Fig. 17), this is not a bus relay misoperation. During the first part of the event, the bus relay saw the transformer relay CT wiring make contact with the bottom of the bushing and properly restrained for this external fault. When the bus relay CT wiring became physically involved in the fault, the bus relay was no longer receiving reliable signals from its CT. This made it impossible for the relay to determine whether the fault was inside or outside of its zone of protection, and the relay operated.

C. Time-Aligned Events

We can overlay the raw event data seen by both the transformer and bus relays on the same time scale to observe the sequence of events. Unfortunately, only the transformer differential relay and the bus differential relays were GPS time-synchronized. The backup overcurrent and breaker failure relay, which recorded the raw data for the high-side transformer CT, was not connected to a GPS clock. Because of this, manual time alignment is necessary to get an estimate of the sequence of events. Fig. 26 shows the raw signals from the B-phase transformer CT (red) and B-phase bus CT (blue) on the same time axis with manual time alignment performed.

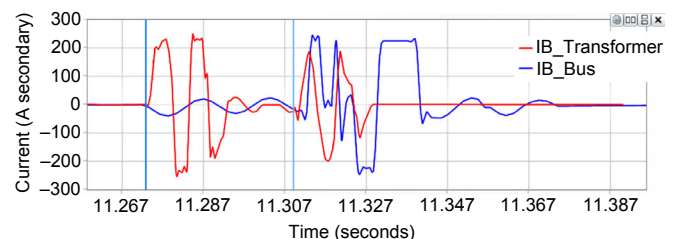

Fig. 26. Raw signals from the B-phase transformer CT (red) and B-phase bus CT (blue)

The first section of the fault, between the two blue vertical lines, shows where the transformer CT wiring made contact with the bottom of the bushing. The bus CT sees the current passing through it to the external fault. The fact that current on the transformer CT changes in magnitude throughout this first section of the fault points to possible arcing. The second

section of the fault, after the second blue vertical line, shows where high currents again began to flow in the transformer CT, and the bus CT also got involved. It is interesting that the current went to zero completely on the transformer CT while the bus CT was still arcing, meaning the circuit switcher had not yet fully broken the fault current. The drop in the transformer CT current is likely a result of the transformer CT wiring burning open and therefore being unable to deliver current to the relay while the bus relay CT wiring was still in the process of melting. The fault current measured by the bus CT goes away exactly 6 cycles after the beginning of the fault, which happens to be the maximum clearing time of the CS1 circuit switcher. This suggests that the circuit switcher was able to clear the fault before the bus CT wiring melted completely.

As the analysis shows, relay event reports hold extremely valuable information. Although there is no substitute for observing actual physical damage to a piece of equipment, it is possible that with knowledge of transformer construction and event report analysis, this entire sequence of events could have been pieced together without ever opening the transformer. In any case, this event is an excellent example of how physical inspection and testing can be combined with relay event analysis to determine the true root cause of an event.

VI. DAMAGE TO RELAYS

The bus and transformer relays were designed to meet and exceed the requirements of relevant IEEE and IEC standards. Compliance with these standards ensures that the relay design is robust and that relay operation is reliable when subjected to fast transients (IEC 61000-4-4), surge events (IEC 61000-4-5), electrostatic discharge (IEEE C37.90.3 and IEC 61000-4-2), dielectric stress (IEEE C37.90 and IEC 60255-5), and other high-stress conditions [12]. However, even a well-designed relay can become damaged when exposed to primary-level currents. It is the purpose of the CT to lower the primary current to a level safe for the relay, as well as provide the necessary isolation between the primary and secondary circuits. In this case study, the CT going to both the bus and transformer relays made contact with the bottom of the bushing and subjected the relays to primary-level currents. In addition to high currents, the fault also exposed the relay current inputs to dangerously high primary-level voltages. Such extreme current and voltage levels can lead to thermal damage and dielectric failure of the relay, respectively.

A. Thermal Damage

Table II shows the published specifications of the ac current inputs of the transformer and bus relays. The inputs of these relays are rated for 5 A nominal, 15 A continuous, and 500 A for 1 second. The transformer relays are rated to handle 625 A for 1 cycle, while the bus relay is rated to handle 1,250 A for 1 cycle. When the current inputs of a microprocessor-based relay are exposed to primary-level currents, the thermal stress can damage the internal relay CTs

and associated wiring. These CTs sit inside the relay and step down the secondary current coming into the relay (5 A nominal, for example) to the milliampere signals needed for the relay circuit boards. Fig. 27 shows the CTs inside a bus differential relay with the front-panel removed.

TABLE II
AC CURRENT INPUT RATINGS

Relay	5 A Nominal Ratings
Transformer differential relay (Relay Y)	15 A continuous, 500 A for 1 second, linear to 100 A symmetrical; 625 A for 1 cycle
Transformer overcurrent backup relay (Relay Z)	15 A continuous, 500 A for 1 second, linear to 100 A symmetrical; 625 A for 1 cycle
Bus differential relay (Relay X)	15 A continuous, 500 A for 1 second, linear to 100 A symmetrical; 1,250 A for 1 cycle

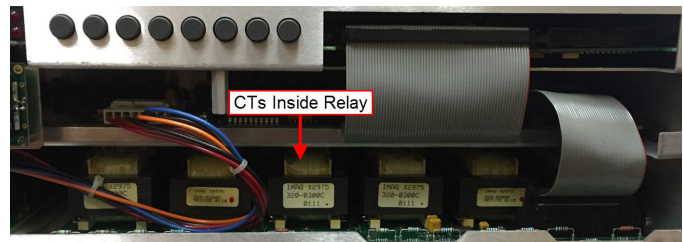

Fig. 27. CTs inside a bus differential relay

Thermal stress can manifest itself in two forms. First, the transformer windings can short together, causing the relay to measure and report an undesired current value proportional to a reduced turns ratio. Second, the leads that connect the internal CTs to the terminal block on the back of the relay can melt. A complete melting of the leads would result in the relay reading no current value on that input. It is possible to detect melted leads with a visual inspection, but knowledge about how to take the relay apart and what to look for is required. An alternative method of verifying the integrity of the internal relay CT circuitry is to perform a metering test. This test validates that the relay is metering within specifications and confirms that no significant thermal damage to the windings or leads has occurred.

Ideally, the event reports the relays captured during the fault could be used to see how much current each relay was exposed to and to compare that with the published rating of the ac current inputs. However, in this event we do not know how much current the relays were actually exposed to because of the A/D clipping (see Section IV). After the fault, the utility performed a visual inspection and found no damage in the control cabinet or the wiring from the control cabinet to the relays. They inspected the internal relay CTs and wiring and found no obvious signs of thermal stress. The utility also ran a full spectrum of metering and functional tests on the transformer and bus relays. All relays passed the tests with no problems found.

B. Dielectric Failure

The current inputs of the bus and transformer relays are rated to withstand 2,500 Vac. Exposing the inputs to primary-level voltages, such as those that occurred in this event, can cause dielectric failure and damage the relay. Dielectric failures can be detected by performing a dielectric strength test and, in some cases, through visual inspection of the relay circuit boards. Metering tests alone are not sufficient to detect these failures. Reference [13] discusses a case where dielectric failure occurred and damage to the relay circuit boards was clearly visible, despite the fact that metering tests after the fault were successful.

The utility in our case study performed a visual inspection of the relay boards after the fault but did not find any visible sign of dielectric failure. Despite no visual indication of failure, performing a dielectric strength test is recommended to ensure that there is no damage to the relay. The utility plans to remove the relays from service and send them to the manufacturer so that this test can be performed and all relays can be thoroughly inspected for damage.

It is somewhat surprising that initial testing and inspection did not detect damage to the relay inputs after they had been exposed to primary-level currents and voltages. It is theorized that the “spark gap effect” of the CT junction box may have helped limit the amount of current and voltage seen at the relay input terminals. A spark gap consists of two terminals a short distance apart—one at line potential and the other at ground potential. In the event of a surge, the voltage difference creates an arc across the terminals, establishing an intentional path to ground and preventing damage to nearby insulation. When the CT secondary wiring made contact with the primary system in this event, the associated stud in the CT junction box was elevated to line potential. The short distance between this stud and the ground terminal created an unintentional spark gap effect and resulted in an inadvertent path to ground. As a result, most of the current was routed away from the relay, effectively reducing the amount of voltage and current seen by the relay inputs.

VII. CONCLUSION

This paper presents a transformer fault that caused a 138 kV substation to go dark when both the bus and transformer relays operated to clear the fault. Further investigation by the utility revealed that the secondary wiring of two high-side bushing CTs made contact with the bottom of the bushing and created a fault inside the transformer. The utility requested assistance from the relay manufacturer in determining whether the event reports they collected from the relays could validate their findings. They also questioned why the bus differential relay operated for this seemingly external fault.

While internal inspection of the transformer gave the utility a starting point, it was event report analysis that proved the true sequence of events and filled in the missing pieces of the puzzle. This analysis validated the root cause that the utility found and showed that the CT secondary wiring going to the transformer relay first made contact with the bottom of the bushing. During that time, the bus relay correctly identified the fault to be external to its zone of protection and restrained. However, 3 cycles into the fault, the CT secondary wiring of the bus relay also became physically involved in the fault. Because the bus relay was no longer receiving reliable current signals from the CT, it calculated a false differential current and operated.

When the CT secondary wiring made contact with the bottom of the bushing, it not only fed unreliable signals to the relays but also exposed both relays to primary-level currents and voltages. This exposure can cause thermal damage to the CTs inside the relay as well as dielectric failure.

Once the root cause of the transformer failure was identified, the process of repairing the transformer began. The utility replaced two 88 kV bushings (H2 and H3), the pressure relief device, and the secondary wiring for all of the CTs. The utility decided not to replace the low-side bushings because they believed that the staining found on those bushings was likely there before the fault occurred and would have been found during routine five-year maintenance testing. The cost of procuring all of this new equipment amounted to thousands of dollars. Other significant costs to the utility included rolling trucks; testing, draining, repairing, and refilling the transformer; personnel time; and revenue lost during the outage.

In this story of primary meeting secondary, there are several important lessons to be learned:

- Engineers and technicians devote countless hours of time and effort to accurately setting, wiring, testing, and commissioning power system equipment. Despite our best efforts, this event shows that the power system can be unforgiving. At the end of the day, all it took was something as simple as excess wire slack to cause a fault, result in an outage, and damage expensive equipment.
- The fault described in this paper was caused by excess slack and a lack of bundling in the CT secondary wiring, which the utility deemed to be a manufacturing defect. Such defects can easily be identified through visual inspection at the time of installation, before the transformer has been fully assembled or filled with oil. Transformers are very expensive pieces of equipment, and requesting a visual inspection before accepting ownership may be worthwhile if it means avoiding a costly and dangerous fault.

- Recall from Section V that the utility did not initially download the raw event report from the transformer relay (Relay Y). By the time engineers realized that they needed the raw data, the transformer had already been repaired and retested, and all previous event reports in the relay had been erased. Luckily in this case, the raw event report from the backup overcurrent relay (Relay Z) was available for use in the analysis. This is a common problem, and it can be easily solved by always downloading all available event types (raw, filtered, differential, and so on) in a relay immediately after a fault. In cases where accessing the relays is difficult (for example, the substation is in a remote location), an automatic event retrieval system can be implemented. This system can be set up to automatically download all types of event reports immediately after a fault and store them on a server for analysis.
- Also recall from Section V that the transformer backup overcurrent relay (Relay Z) was not connected to a GPS time source. In order to understand the true sequence of events, we had to manually align the raw event report from this relay with the event from the bus differential relay. Had all the relays in the substation been time-synchronized, this analysis would have been simpler and more accurate. GPS clocks and associated wiring are a trivial expense, and time-synchronizing all relays in a substation is always recommended.
- Relay event reports contain extremely valuable information that can be used to determine the root cause of a fault. For example, it may have been possible to piece together this event without ever opening the transformer. Even if the cause of the fault is known and everything operated correctly, we still recommended downloading and analyzing the event reports the relay captured. The information contained in these reports can be used to understand complex faults and validate physical findings, relay operation, relay settings, and so on.
- If a relay is exposed to primary-level currents and voltages, it is necessary to test and inspect the relay for thermal damage and dielectric failure. Even if the relay passes physical inspection, metering tests, and functional tests, we recommend always returning the relay to the manufacturer for full dielectric testing and thorough inspection.
- Finally, the analysis of this event would have been much more difficult without a basic understanding of transformer construction. It is important for protection engineers to not just be comfortable with relay settings, but to also be knowledgeable and familiar with the physical construction of the equipment they are protecting. The ability to analyze relay event reports and the understanding of equipment construction can be a very powerful combination when analyzing complex power system events.

VIII. APPENDIX: TRANSFORMER NAMEPLATE

Fig. 28 shows the nameplate of Transformer T1.

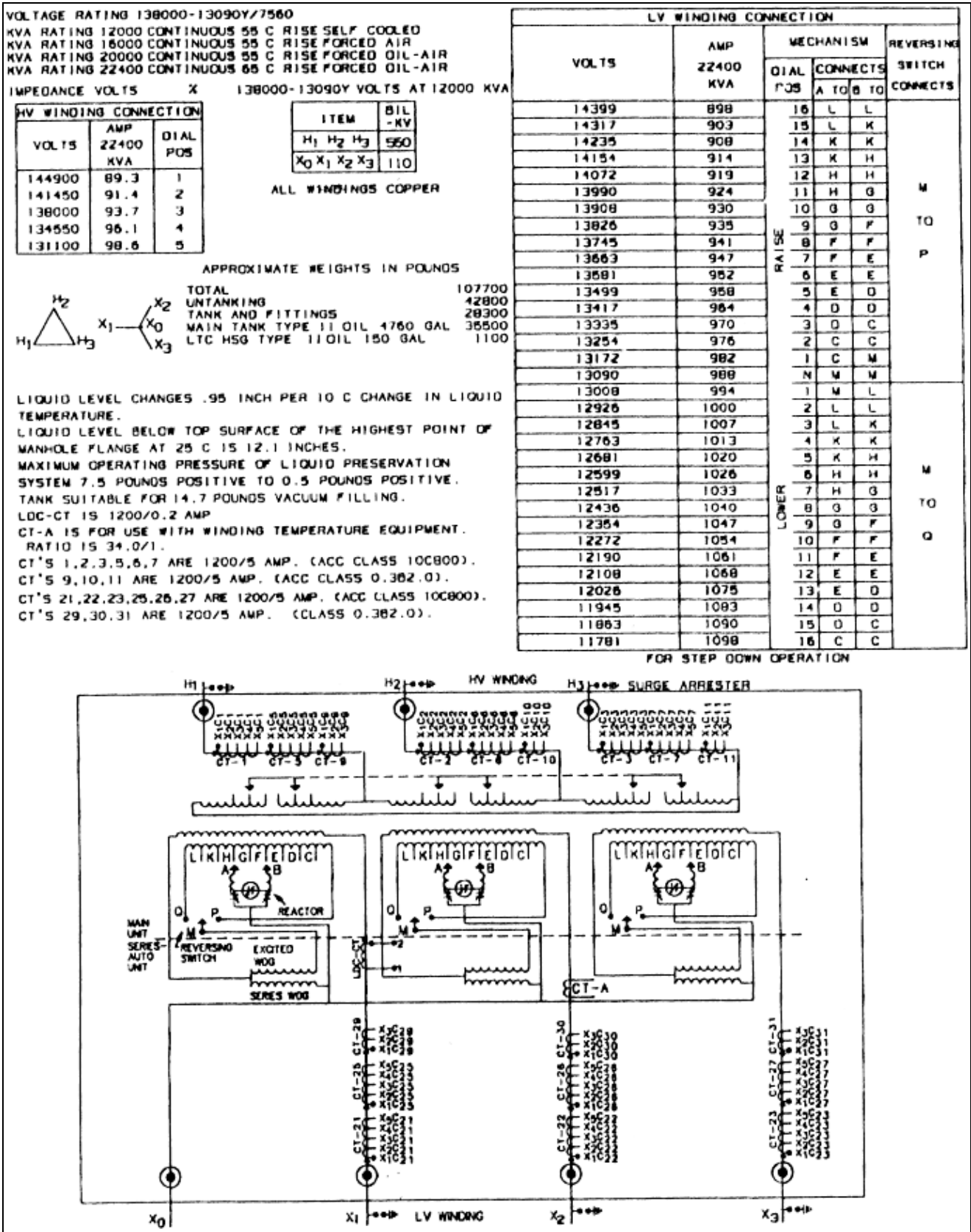

Fig. 28. Nameplate of Transformer T1

IX. REFERENCES

- [1] A. Guzmán, C. Labuschagne, and B. Qin, "Reliable Busbar and Breaker Failure Protection With Advanced Zone Selection," proceedings of the 31st Annual Western Protective Relay Conference, Spokane, WA, October 2004.
- [2] K. Behrendt, D. Costello, and S. E. Zocholl, "Considerations for Using High-Impedance or Low-Impedance Relays for Bus Differential Protection," proceedings of the 63rd Annual Conference for Protective Relay Engineers, College Station, TX, March 2010.
- [3] C. Labuschagne, R. Moxley, E. Jessup, and J. Needs, "Low-Impedance Bus Differential – Security and Reliability in Complex Bus Arrangements," proceedings of the 11th International Conference on Developments in Power System Protection, Birmingham, United Kingdom, April 2012.
- [4] M. Thompson, R. Folkers, and A. Sinclair, "Secure Application of Transformer Differential Relays for Bus Protection," proceedings of the 58th Annual Conference for Protective Relay Engineers, College Station, TX, April 2005.
- [5] M. J. Thompson, "Percentage Restrained Differential, Percentage of What?" proceedings of the 64th Annual Conference for Protective Relay Engineers, College Station, TX, April 2011.
- [6] B. Edwards, D. G. Williams, A. Hargrave, M. Watkins, and V. K. Yedidi, "Beyond the Nameplate – Selecting Transformer Compensation Settings for Secure Differential Protection," proceedings of the 70th Annual Georgia Tech Protective Relaying Conference, Atlanta, GA, April 2016.
- [7] J. H. Harlow (ed.), *Electric Power Transformer Engineering*. 3rd ed. CRC Press – Taylor & Francis Group, Boca Raton, FL, 2012.
- [8] IEEE Standard C57.125-2015, IEEE Guide for Failure Investigation, Documentation, Analysis, and Reporting for Power Transformers and Shunt Reactors.
- [9] IEEE Standard C57.104-2008, IEEE Guide for the Interpretation of Gases Generated in Oil-Immersed Transformers.
- [10] United States Department of the Interior Bureau of Reclamation, "Transformer Diagnostics," June 2003. Available: https://www.usbr.gov/power/data/fist/fist3_31/fist3-31.pdf.
- [11] IEEE Standard C57.152-2013, IEEE Guide for Diagnostic Field Testing of Fluid-Filled Power Transformers, Regulators, and Reactors.
- [12] J. T. Tengdin, K. Fodero, and R. Schwartz, "Ensuring Error-Free Performance of Communications Equipment," proceedings of the 11th Annual Western Power Delivery Automation Conference, Spokane, WA, April 2009.
- [13] D. Costello, "Open-Circuited CT Misoperation and Investigation," proceedings of the 67th Annual Conference for Protective Relay Engineers, College Station, TX, March 2014.

X. BIOGRAPHIES

Genardo Corpuz received his B.S.E. in electrical engineering from the University of Texas, Austin, in 2005. He is a licensed professional engineer (PE) in the state of Texas and currently works at the Lower Colorado River Authority (LCRA) in Austin, Texas. His work experience includes substation design and system protection.

Swagata Das received her B.Tech degree from SRM University in Chennai, India, in 2009. She received her M.S.E. and Ph.D. degrees in electrical engineering from the University of Texas, Austin, in 2011 and 2015, respectively. Swagata joined Schweitzer Engineering Laboratories, Inc. in 2015 and works as an associate application engineer in protection out of the Fair Oaks Ranch, Texas, office. She is a member of IEEE.

Ariana Hargrave earned her B.S.E.E., magna cum laude, from St. Mary's University in San Antonio, Texas, in 2007. She graduated with a master of engineering degree in electrical engineering from Texas A&M University in 2009, specializing in power systems. Ariana joined Schweitzer Engineering Laboratories, Inc. in 2009 and works as a protection application engineer in Fair Oaks Ranch, Texas. She is a registered professional engineer (PE) in the state of Texas.