

SEL-710

Motor Protection Relay



Maximize process uptime with the SEL-patented motor thermal model

- Optimize motor performance with separate thermal models for the stator and rotor.
- Monitor stator and ambient temperatures for sensitive and secure protection.
- Apply overcurrent elements for complete backup protection in one low-cost, flexible, industrial form factor.



Functional Overview

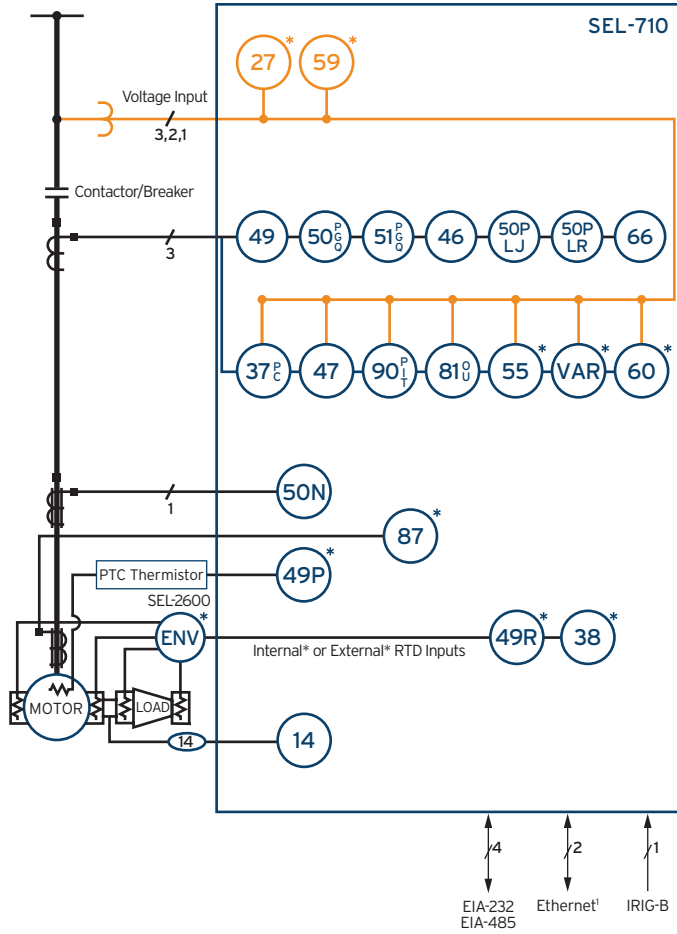

ANSI Numbers/Acronyms and Functions

| | |
|------------|---|
| 14 | Speed Switch |
| 27 | Undervoltage* |
| 37 (P,C) | Underpower/Undercurrent |
| 38 | Bearing Temperature* |
| 46 | Current Unbalance |
| 47 | Phase Reversal |
| 49P | PTC Overtemperature* |
| 49R | RTD Thermal* |
| 49T | Thermal Model |
| 50 (P,G,Q) | Overcurrent (Phase, Ground, Neg. Seq.) |
| 50P LR | Locked Rotor |
| 50P LJ | Load Jam |
| 50N | Neutral Overcurrent |
| 51 (P,G,Q) | Time-Overcurrent (Phase, Residual, Neg. Seq.) |
| 55 | Power Factor* |
| 59P | Phase Overvoltage* |
| 60 | Loss-of-Potential* |
| 66 | Starts-Per-Hour |
| 81 (O,U) | Over-/Underfrequency |
| 87 | Current Differential* |
| 90 (P,I,T) | Load Control (Power, Current, Thermal Capacity) |

Additional Functions

| | |
|--------|--|
| 50/51 | Adaptive Overcurrent |
| 85 RIO | SEL MIRRORING BITS® Communications |
| DFR | Event Reports—Motor Starts, Motor Operating Statistics |
| ENV | Optional SEL-2600 RTD Module* |
| HMI | Operator Interface |
| LDP | Load Data Profiling |
| LGC | SELogic® Control Equations |
| MET | Metering |
| RTU | Remote Terminal Unit |
| SDTM | Slip-Dependent AccuTrack™ Thermal Model |
| SER | Sequential Events Recorders |

¹ Copper or Fiber-Optic

*Optional Feature



Key Features

Optimize Start Times

Calculate the thermal energy in the motor to determine maximum safe start times with full motor protection. Accurate temperature tracking also minimizes the time needed between starts.

Convenient Controls

Use the four programmable pushbuttons on the front panel for quick, personalized control, including factory default start and stop functions.

Advanced Protection

Provide overcurrent, thermal overload, undercurrent, current unbalance, current differential, phase loss, ground fault, and over- or underfrequency protection and much more.

Easy Communications

Choose from single or dual copper or fiber-optic Ethernet, Modbus[®] TCP, IEC 61850, Modbus Serial, EIA-232, EIA-485, Telnet, and FTP protocols. Pick one or multiple connections, including multiple Modbus sessions for the custom configuration of your application.

Reliable Rugged Hardware

Apply the SEL-710 Motor Protection Relay in extreme conditions, with an operating temperature range of -40° to $+85^{\circ}\text{C}$ (-40° to $+185^{\circ}\text{F}$). The SEL-710 is designed and tested to exceed applicable standards, including those for vibration, electromagnetic compatibility, and adverse environmental conditions.



Product Overview

Use default messages, or program up to 32 custom display labels.

Large 2 × 16 character LCD.

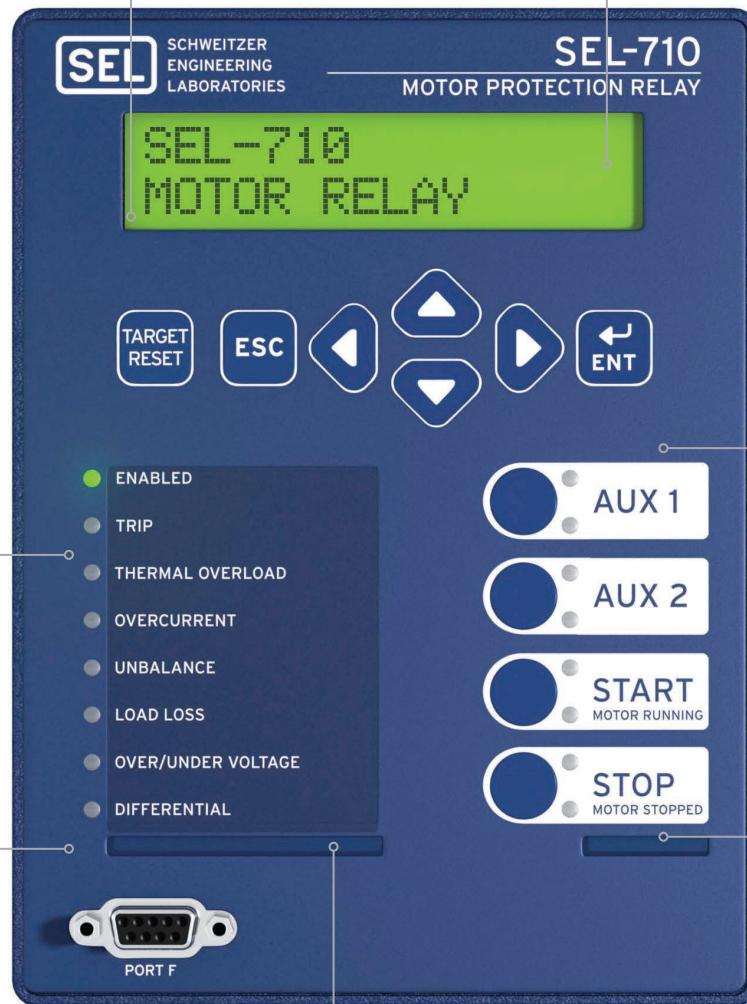

Front-panel LEDs can be programmed to indicate custom alarms.

Use default pushbuttons, or program your own pushbutton actions and labels.

User-configurable label kit included with the relay.

Power supply options include 24–48 Vdc, 110–250 Vdc, and 110–240 Vac.

IRIG-B or PTC input.

Optional Ethernet, Modbus[®] TCP, and/or IEC 61850.

Port 1 concurrently supports two Modbus TCP, two FTP, two Telnet, one SNTP, and six IEC 61850 sessions.

MIRRORED BITS[®] communications.

Positions for optional I/O cards shown with 4 DI/4 DO card, RTD input card, and voltage and current differential input card.

CT inputs include a sensitive neutral option.

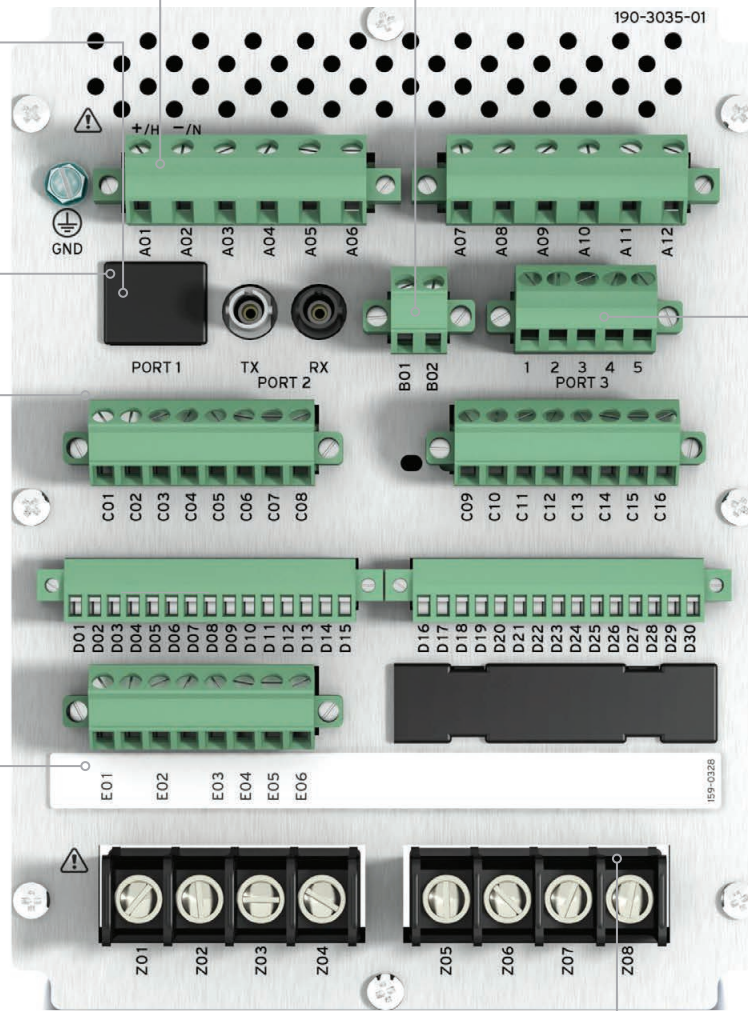

Applications

Complete Control Application

The SEL-710 also provides many functions of a programmable logic controller (PLC). Multiple communications options, a variety of I/O choices, and programmable SELogic control equations make the SEL-710 a complete solution.

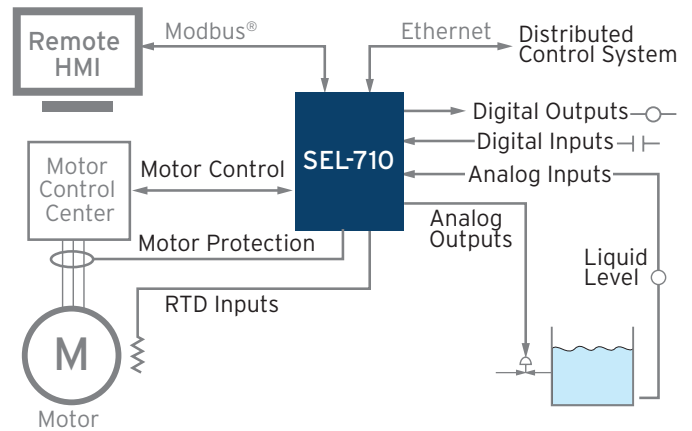

High-Inertia Starting Application

The SEL-710 provides the best protection and starting opportunities for high-inertia starting applications because the real-time calculation of changing motor slip and rotor resistance is used to calculate motor thermal rise and maximize safe starting times. This safely provides a longer period of time for high-inertia motors to start. Using a constant value for motor resistance throughout the start sequence results in premature trips and reduced start opportunities. Use the SEL-710 to eliminate guesswork, starting timers, and speed switches.

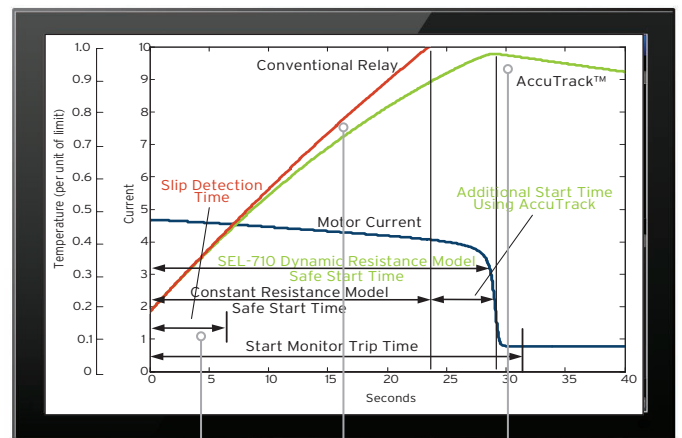

Determine the motor rotation without a speed switch.

The SEL-710 accounts for changing resistance and allows enough time to start.

Using conventional motor protection with constant motor resistance causes premature trips.

Accessories

Retrofit Replacement

Replace existing motor protection with the SEL-710 and applicable mounting kit. These kits provide everything needed to replace many existing motor relays with the SEL-710.

No cutting or drilling is required when you use the optional mounting kits. Replacement of existing protection is quick and easy!

Card Options

- EIA-232 front, EIA-232 or EIA-485 rear, fiber-optic serial port multimode (ST[®]), single/dual 10/100BASE-T or 100BASE-FX Ethernet port
- 4 digital outputs (DO), 3 digital inputs (DI), 1 analog output (AO) (4–20 mA)
- 8 DI
- 4 DO, 4 DI
- 4 fast hybrid DO, 4 DI
- 4 DI, 3 DO (2 Form C and 1 Form B)
- 8 analog inputs (AI) (up to ± 10 V or ± 20 mA)
- 4 AI, 4 AO (up to ± 10 V or ± 20 mA)
- EIA-232/EIA-485 serial communications
- 10 resistance temperature detector (RTD) inputs
- AC voltage inputs
- Current differential, including ac voltage inputs

Other Options

- Positive temperature coefficient (PTC) or IRIG-B input
- High-sensitivity (2.5 mA) neutral current input
- Rack-mounting plates
- Retrofit-mounting kits
- Conformal coating



Flexible Communications

Easy Integration With Control Systems

Several communications protocol options allow the SEL-710 to be used with old and new control systems. Flexible, multichannel communications options include:

- Single or dual Ethernet, 10/100BASE-T copper, or 100BASE-FX fiber-optic
- Modbus TCP or RTU
- IEC 61850
- Telnet
- FTP
- Simple Network Time Protocol (SNTP)
- EIA-232 up to 38.4 kbps
- EIA-485

Front-Panel Targets and Messages

Program front-panel targets to indicate any relay element operation, and modify front-panel labeling via a customizable slide-in card. Extra cards and a Microsoft® Word® template are available.

The relay automatically determines the trip type and displays this information on the front-panel display. Trip type messages reveal the motor-operating conditions that tripped the relay:

- Thermal and locked rotor
- Load loss and load jam
- Current unbalance
- Phase and ground fault
- Voltage or current differential



Simple or Advanced Settings

Advanced Control

For more control, use Microsoft Windows®-based acSELErATOR QuickSet® SEL-5030 Software to guide you through the settings process.

- Save engineering time while maintaining flexibility. Communicate with the SEL-710 through any ASCII terminal, or use the acSELErATOR QuickSet graphical user interface.
- Develop settings offline with a menu-driven interface and completely documented help screens. Speed up installation by copying existing settings files and modifying application-specific items.
- Simplify the settings procedure with rules-based architecture to automatically check interrelated settings. Out-of-range or conflicting settings are highlighted for correction.
- Transfer settings files from a PC to the SEL-710.

Nameplate Settings

For fast, basic protection, simply enter 14 values of nameplate data directly into the front panel.

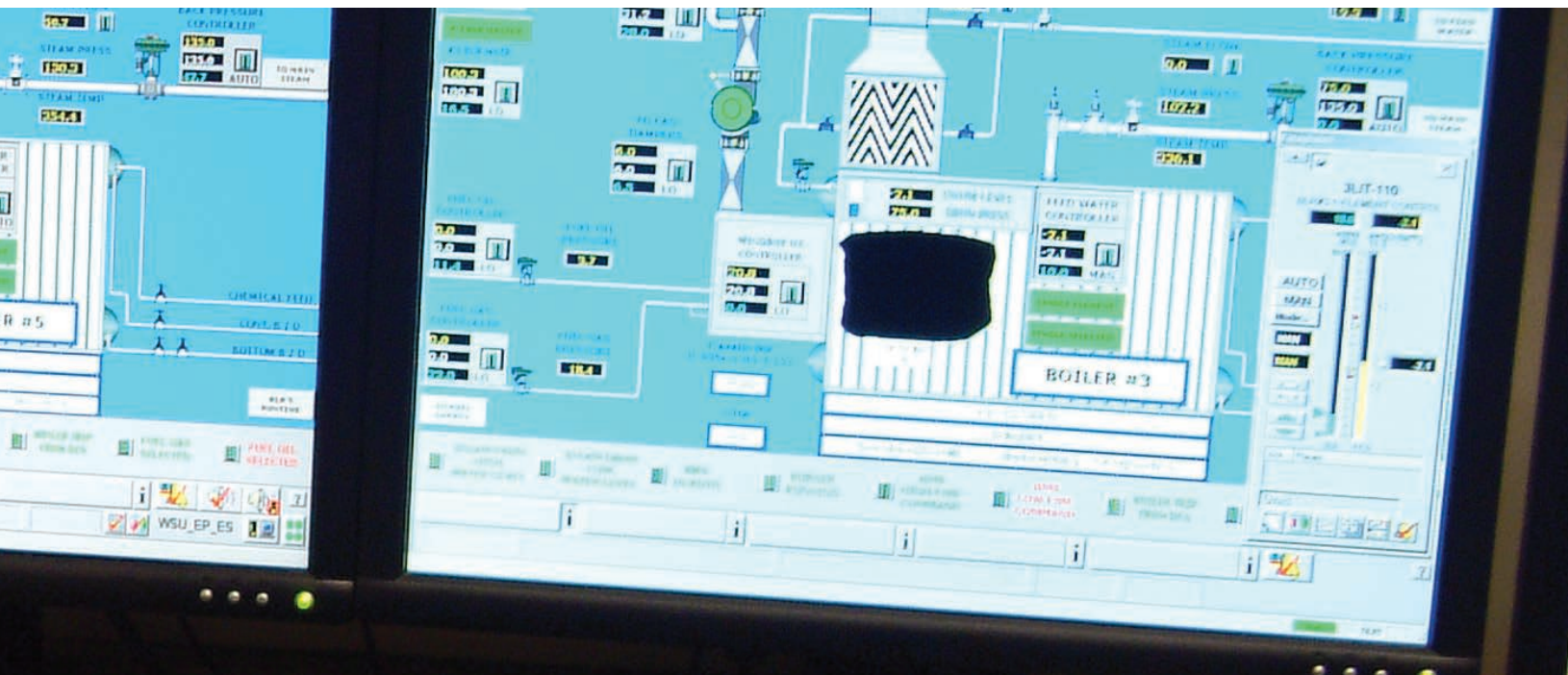
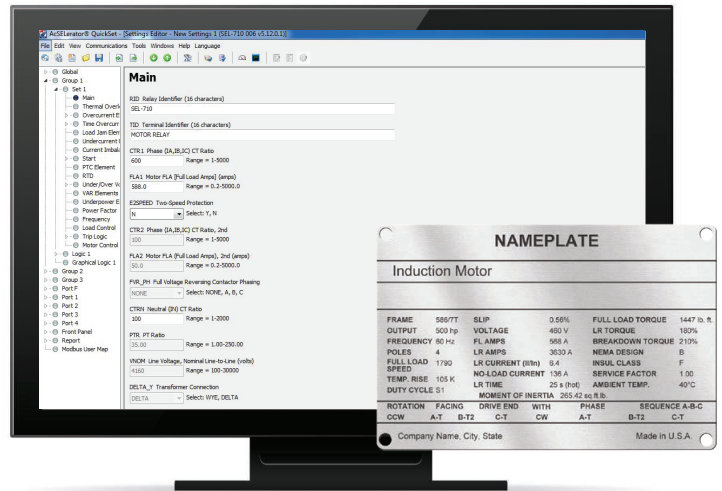

Reporting and Troubleshooting

Sequential Events Recorder (SER)

The SEL-710 tracks the pickup and dropout of protection elements, control inputs, and contact outputs. The date and time of each transition are available in an SER report.

This chronological report helps you determine the order and cause of events and assists in troubleshooting and root-cause analysis.

Event and Motor-Start Reports

The SEL-710 captures a 15-cycle or a 64-cycle event report and creates an event summary each time the relay trips in response to programmable conditions. The relay stores up to 77 of the most recent 15-cycle events or 19 of the most recent 64-cycle events. View the event summaries on the relay's LCD, or connect to a computer to view the complete event reports in tabular form or as oscillographs showing analog and digital quantities.

Motor starts and motor start trend data are also captured. The relay stores as many as five of the latest motor starts in nonvolatile memory. Important starting quantities are trended to provide key information about changing motor performance over time.

Circuit Breaker Contact Wear Monitor

Circuit breakers experience mechanical and electrical wear every time they operate. Intelligent scheduling of breaker maintenance takes into account the manufacturer's published data of contact wear versus interruption levels and operation count. With the breaker manufacturer's maintenance curve as input data, the SEL-710 breaker monitor feature compares this input data to the measured (unfiltered) ac current at the time of the trip and the number of close-to-open operations.

Every time the breaker trips, it integrates the measured current information. When the result of this integration exceeds the breaker wear curve threshold, the relay alarms via the output contact, communications port, or front-panel display. This kind of information allows timely and economical scheduling of breaker maintenance.

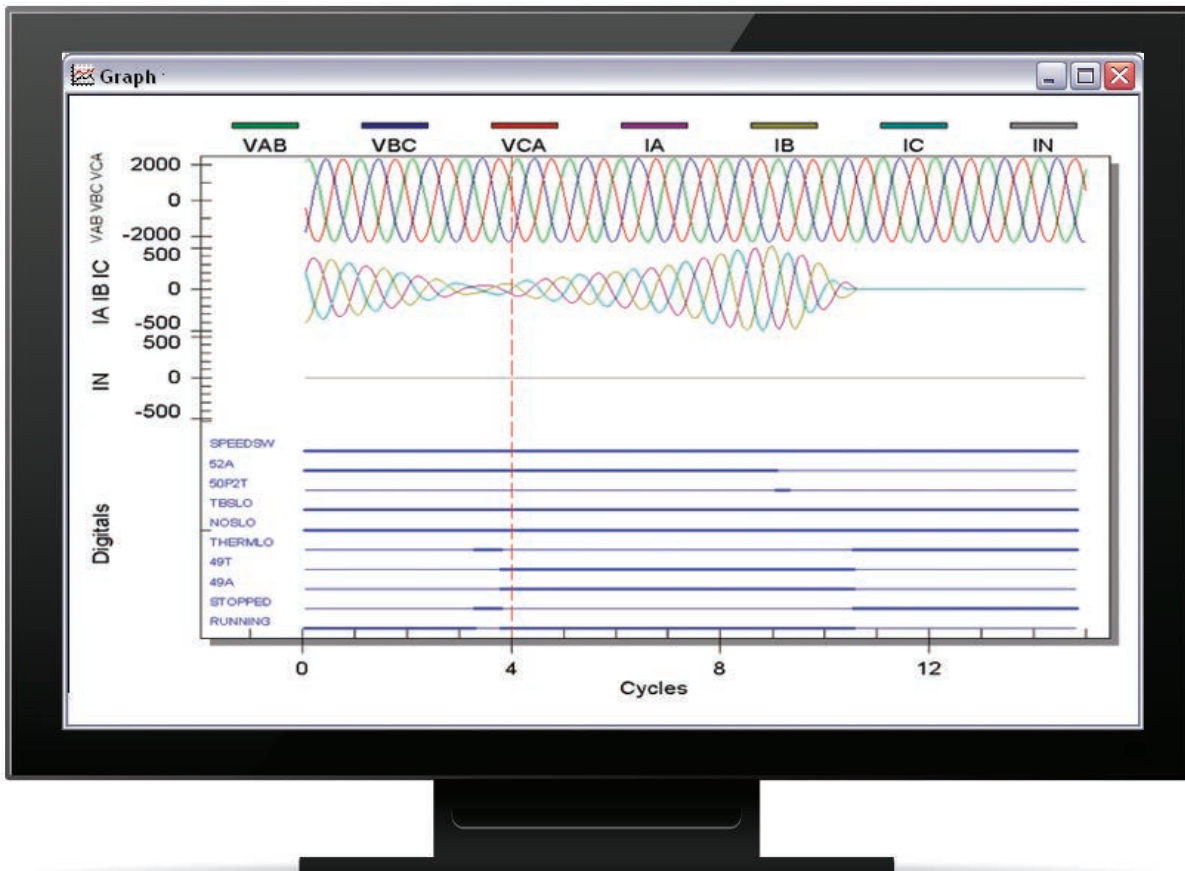

SEL-710 time-synchronized event report.

Motor Temperature

Motor Thermal Overload Protection

The SEL-710 provides locked-rotor, running overload, and negative-sequence current unbalance protection using the AccuTrack Thermal Model. The SEL-710 accurately tracks the heating effects of the load current and current unbalance during the motor's operating conditions (starting and running).

Motor heating depends on current and resistance. Accurately measuring the current and calculating the changing resistance results in the most accurate thermal model available. Monitor and track the thermal capacity used (% TCU) with the SEL-710.

Fast Current Differential Protection

The differential element supports two types of current transformer connections: three flux-balancing CTs or six CTs externally connected in a summing arrangement.

Thermal Model Elements

The SEL-710 AccuTrack Thermal Models replicate heating and cooling characteristics of the rotor and stator simultaneously. A rotor thermal model provides starting protection, which incorporates the slip-dependent positive- and negative-sequence rotor resistances to accurately track the rotor temperature. A separate stator thermal model provides overload protection. The models calculate rotor and stator temperatures in real time, and trip is asserted if either the rotor or stator thermal limit is exceeded.

Current Distribution in the Rotor Bar

As the motor starts, the rotor resistance and heating decrease. The SEL-710 accurately accounts for this change. This translates into the locked-rotor resistance value of about three times the resistance at running. This solves the high-inertia starting problem and minimizes the time between starts.

Tracking Motor Temperature

The excellent motor temperature tracking capability of the SEL thermal overload model is demonstrated with motors driving cyclic overloads. Motor applications such as crushers and chippers can routinely and cyclically overload normal motor operating ratings. These cyclic overloads cause an ordinary overcurrent-based thermal model relay to false-trip, causing unnecessary process downtime. Test data comparing actual motor measurements and the SEL thermal model show how the AccuTrack Thermal Model accurately tracks motor heating throughout the entire cycle of a cyclic overload condition.

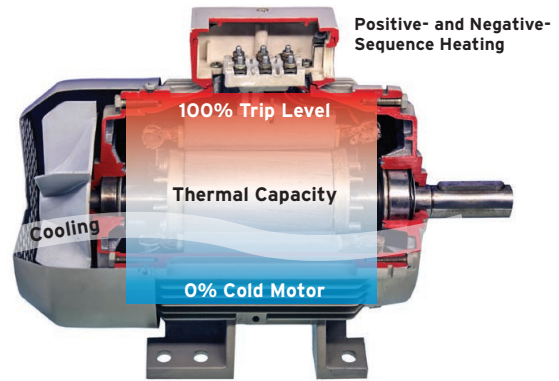

Thermal capacity is affected by positive-sequence heating, negative-sequence heating, and motor cooling.

Rotor Bar Cross Section

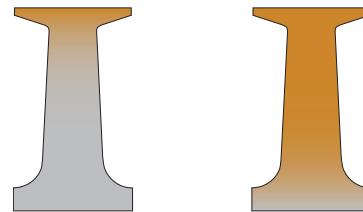

Starting slip = 1 Operating slip = 0.03
Line freq. = 60 Hz Slip freq. = 1.8 Hz

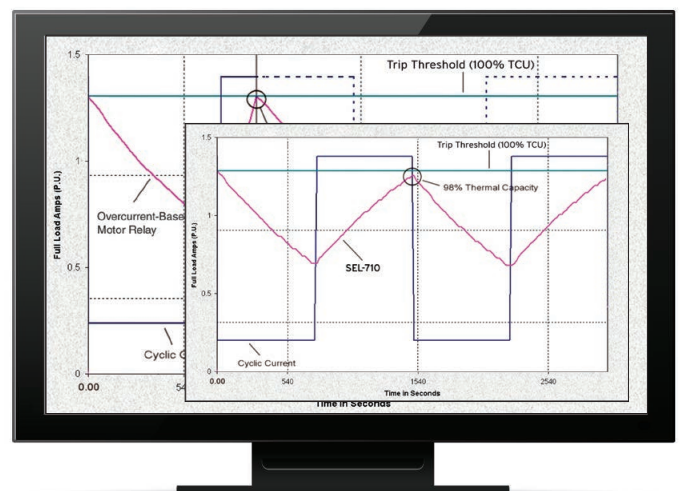

SEL-710 Specifications

General

| | |
|-------------------------------------|--|
| AC Current Inputs | 5 A or 1 A phase and 5 A, 1 A, or 2.5 mA (high sensitivity) neutral, depending on model |
| AC Voltage Inputs | 300 Vac continuous, 600 Vac for 10 seconds |
| Output Contacts | The relay supports Form A, B, and C outputs. |
| Pickup and Dropout Times | Pickup time: ≤8 ms for standard output contact <50 μs (resistive load) for hybrid output contact Dropout time: ≤8 ms for standard output contact ≤8 ms (resistive load) for hybrid output contact |
| Optoisolated Control Inputs | DC/AC control signals: 250, 220, 125, 110, 48, or 24 V |
| Frequency and Phase Rotation | System frequency: 50, 60 Hz Phase rotation: ABC, ACB Frequency tracking: 20–70 Hz |
| Power Supply | 110–250 Vdc or 110–240 Vac Input voltage range: 85–300 Vdc or 85–264 Vac 24–48 Vdc Input voltage range: 19.2–60 Vdc |
| Operating Temperature | –40° to +85°C (–40° to +185°F) |



Making Electric Power Safer, More Reliable, and More Economical
+1.509.332.1890 | info@selinc.com | selinc.com

© 2017–2019 by Schweitzer Engineering Laboratories, Inc.
PF00138 • 20190404

