

TOP VIEW
(ALUMINUM SWING PANEL AND CHASSIS)

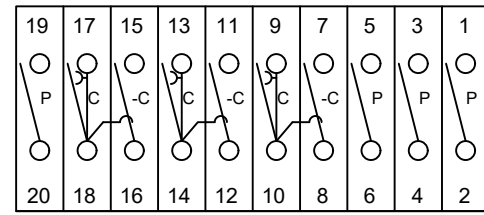

TEST SWITCH CONFIGURATION
(REAR VIEW)

Form 5 Wiring			
TERM	Label	TERM	Label
735-Z01	Z01	TS-07	7-IA*
735-Z02	Z02	TS-09	9-IA
735-Z05	Z05	TS-15	15-IC*
735-Z06	Z06	TS-17	17-IC
735-Z07	Z07	TS-01	1-VA
735-Z08	Z08	735-Z10	Z10
735-Z08	Z08	TS-03	3-VB
735-Z09	Z09	TS-05	5-VC
735-Z10	Z10	TS-19	19-VN
735-GND	735-GND	GND	GND

Form 9 Wiring			
TERM	Label	TERM	Label
735-Z01	Z01	TS-07	7-IA*
735-Z02	Z02	TS-09	9-IA
735-Z03	Z03	TS-11	11-IB*
735-Z04	Z04	TS-13	13-IB
735-Z05	Z05	TS-15	15-IC*
735-Z06	Z06	TS-17	17-IC
735-Z07	Z07	TS-01	1-VA
735-Z08	Z08	TS-03	3-VB
735-Z09	Z09	TS-05	5-VC
735-Z10	Z10	TS-19	19-VN
735-GND	735-GND	GND	GND

Form 36 Wiring			
TERM	Label	TERM	Label
735-Z01	Z01	TS-07	7-IA*
735-Z02	Z02	TS-09	9-IA
735-Z03	Z03	TS-11	11-IB*
735-Z04	Z04	TS-13	13-IB
735-Z05	Z05	TS-15	15-IC*
735-Z06	Z06	TS-17	17-IC
735-Z07	Z07	TS-01	1-VA
735-Z09	Z09	TS-05	5-VC
735-Z10	Z10	735-Z08	Z08
735-Z10	Z10	TS-19	19-VN
735-GND	735-GND	GND	GND

NOTES:

- FOR MOUNTING INFORMATION, SEE DIMENSION DRAWING i9101.
- ENCLOSURE DOES NOT INCLUDE PENETRATIONS FOR FIELD WIRING.

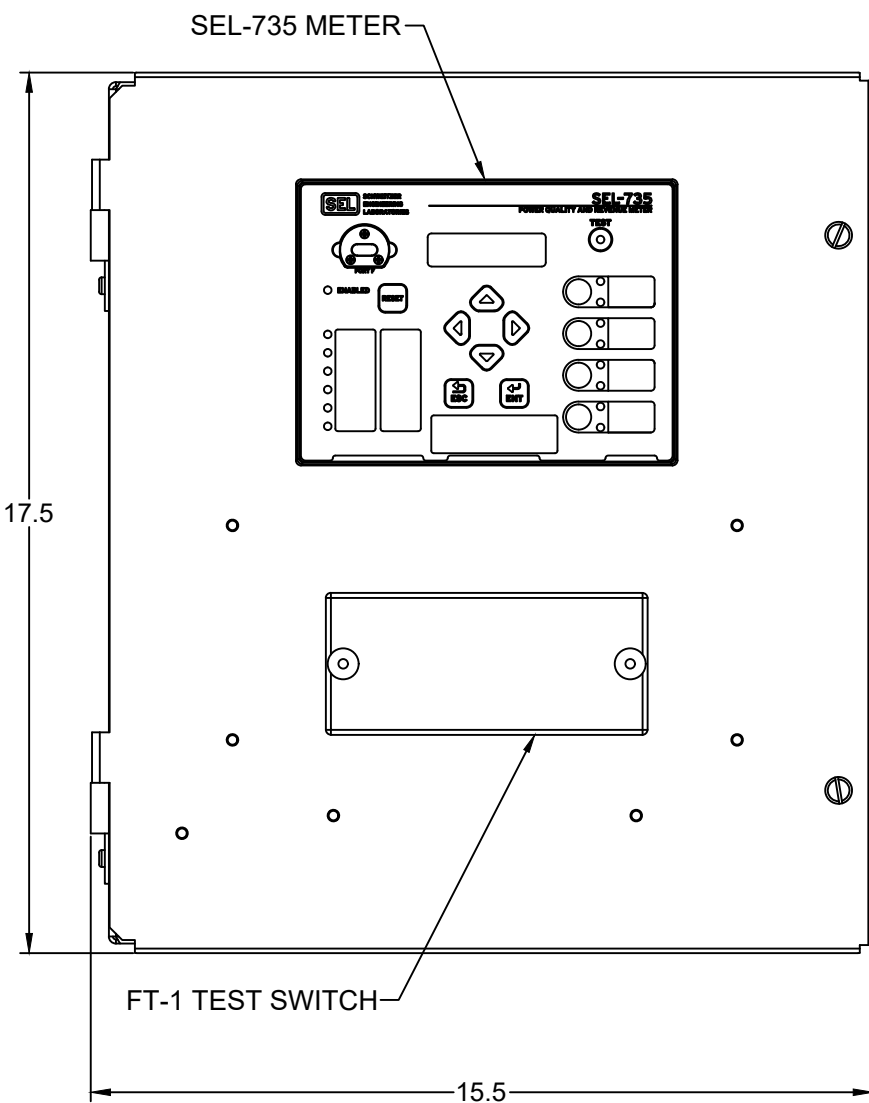

FRONT VIEW
(ALUMINUM SWING PANEL AND CHASSIS)

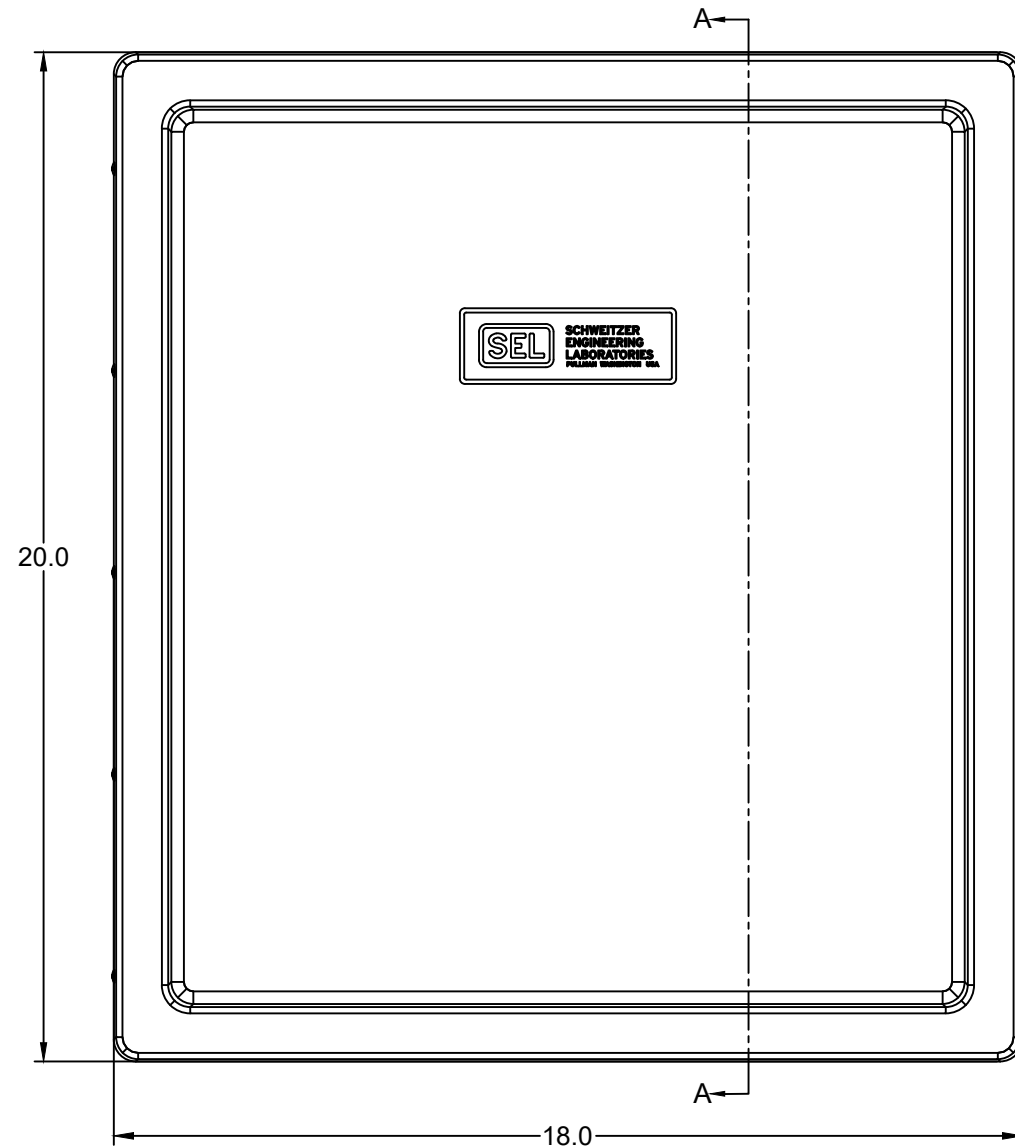

FRONT VIEW
(UL TYPE 4X FIBERGLASS ENCLOSURE)

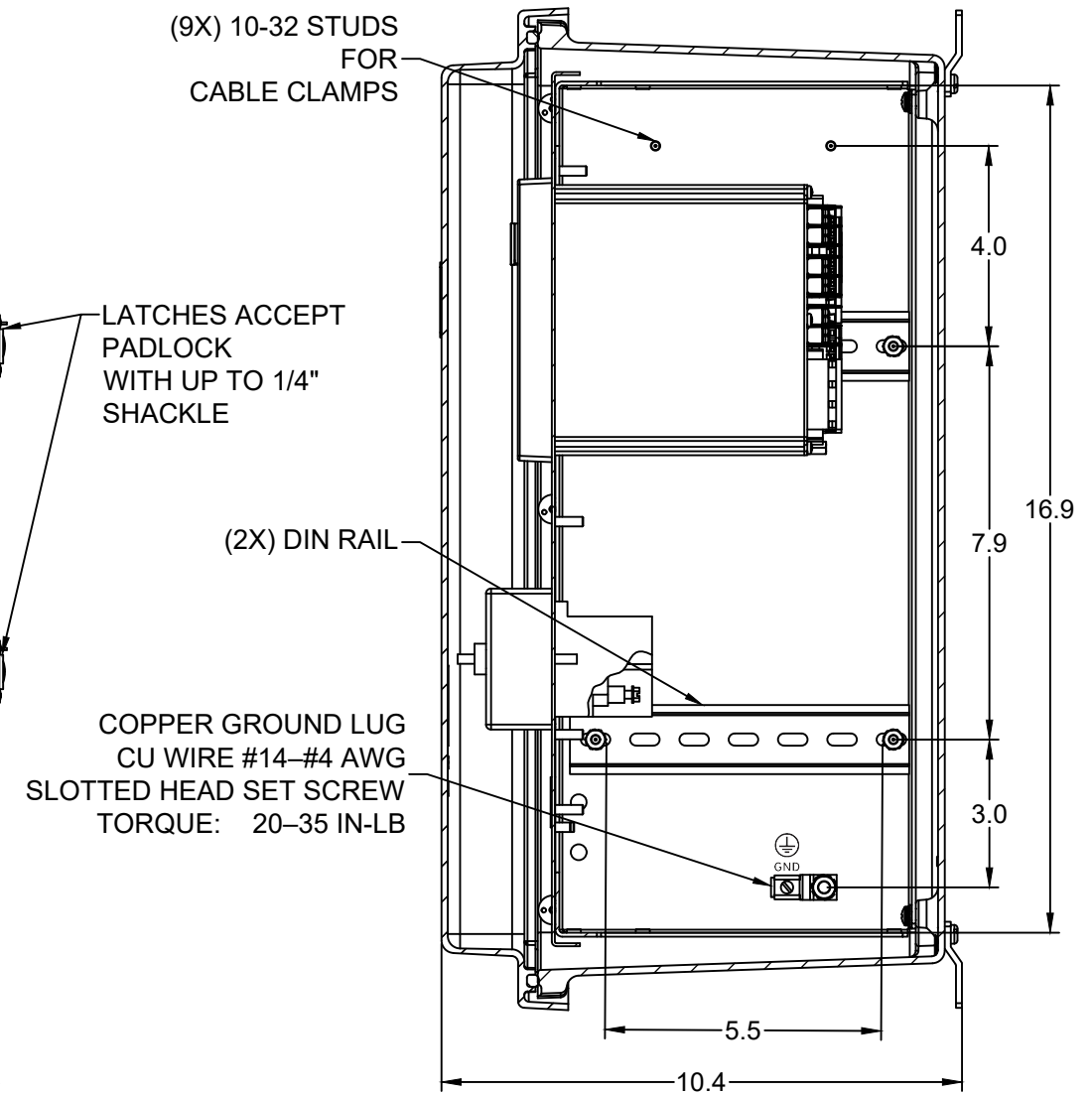

SECTION A-A

SEL-735 HORIZONTAL FORM 5, 9, & 36 WIRING 0735[H]A[B]0****X**XX**2XX		LAYOUT DRAWING DRAFTER: A. JAYKUMAR ENGINEER: B. LAFERRIERE		DATE: 4/12/18 REV: C	
SCALE: NTS	DWG NO: LDW7350001	REV: 1	OF: 1	REV: C	REV: C
SCHWEITZER ENGINEERING LABORATORIES, INC. 2501 NE Hopkins Court, Plummer, WA 99603-9500 USA SEL <small>This document and all information contained herein is proprietary to Schweitzer Engineering Laboratories, Inc. Any unauthorized use, distribution, or reproduction of this document (in whole or in part) or of any information contained herein is specifically prohibited. This legend must appear on any authorized reproduction (in whole or in part). COP-RIGHT © SEL2018</small>		REV. NO. A B C	DATE 7/15/13 1/16/15 4/12/18	APPROVAL D. HAMILTON C. CARVER B. LAFERRIERE	DESCRIPTION INITIAL DRAFT ADDED FORM 36 WIRING TABLE ADDED GROUND WIRING