

SEL Real-Time Automation Controller (RTAC)

Product Family



Rugged, deterministic, and reliable automation controllers for any environment

- 1 ms deterministic processing intervals support critical protection and automation control.
- Integrated human-machine interface (HMI) with HTML5 technology provides comprehensive data visualization.
- exe-GUARD® allowlist antivirus technology permits only authorized applications to run.
- One software program for all RTACs reduces training and provides flexibility for any application.



The SEL RTAC

The SEL RTAC product family is designed to provide you with simple solutions to full-scale automation. Each RTAC puts more data and real-time control at your fingertips for a more comprehensive system view and the ability to quickly address potential issues.

The SEL RTAC offers everything from powerful data management solutions to precise, deterministic control in any location. Integrated cybersecurity features facilitate secure, mission-critical monitoring and control, while assuring regulatory compliance. Precision Time Protocol (PTP) and demodulated IRIG-B inputs synchronize the RTAC and connected intelligent electronic devices (IEDs) to absolute time. User-programmable processing rates and task priorities ensure critical operations run deterministically. In addition, all RTACs have the same user interface, allowing you to share projects across models using the common programming software.

With our ten-year worldwide warranty and unmatched technical support, any RTAC you choose is the right choice for high-speed, deterministic automation.



Applications

Data Concentration and Engineering Access

The RTAC can operate as your data concentrator through several advanced, built-in client and server protocols, such as IEC 61850 MMS, Modbus, DNP3, LG 8979, IEC 60870-5-101/104, and SEL protocols. The ability to integrate both serial and Ethernet IEDs allows a single RTAC in your substation to provide secure engineering access to the connected devices from a remote location so that you can conveniently configure your IEDs, monitor logs, and analyze diagnostics.

Power System Automation

Use the RTAC as the “brains” inside your substation to deploy high-performance control and monitoring schemes. By bridging the connection between MIRRORRED BITS® communications and IEC 61850 Generic Object-Oriented Substation Event (GOOSE) networks, these efficient automation controllers give you the most secure and reliable communications. With applications like directional element-based bus protection and replacement of tone-channel equipment for communications-assisted blocking, unblocking, permissive, and transfer trip schemes, the RTAC provides a highly deterministic automation platform solution.

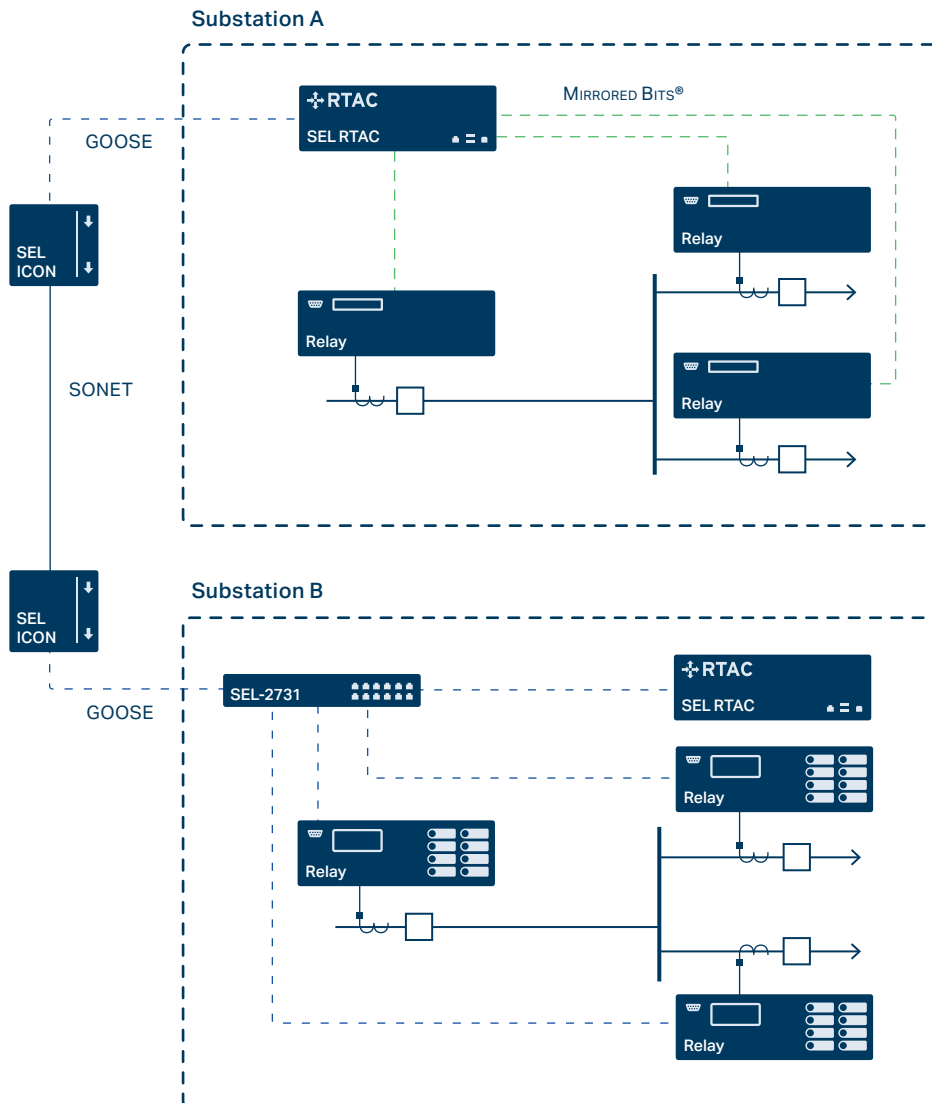

Digital Fault Recorder (DFR)

Use the RTAC and modular SEL-2240 Axion® I/O platform to implement a DFR system with 24 kHz event recording that scales to up to 96 channels. Implement a solution that supports your NERC PRC-002 compliance efforts by continuously recording oscillography data at 3,000 samples per second for ten days or more. In addition, the system captures hundreds of digital input statuses using SEL-2244-2 Digital Input Modules. Retain long-term data using reliable SSD storage in the controller for all fault records, dynamic disturbance records, and Sequence of Events (SOE) records in the substation.

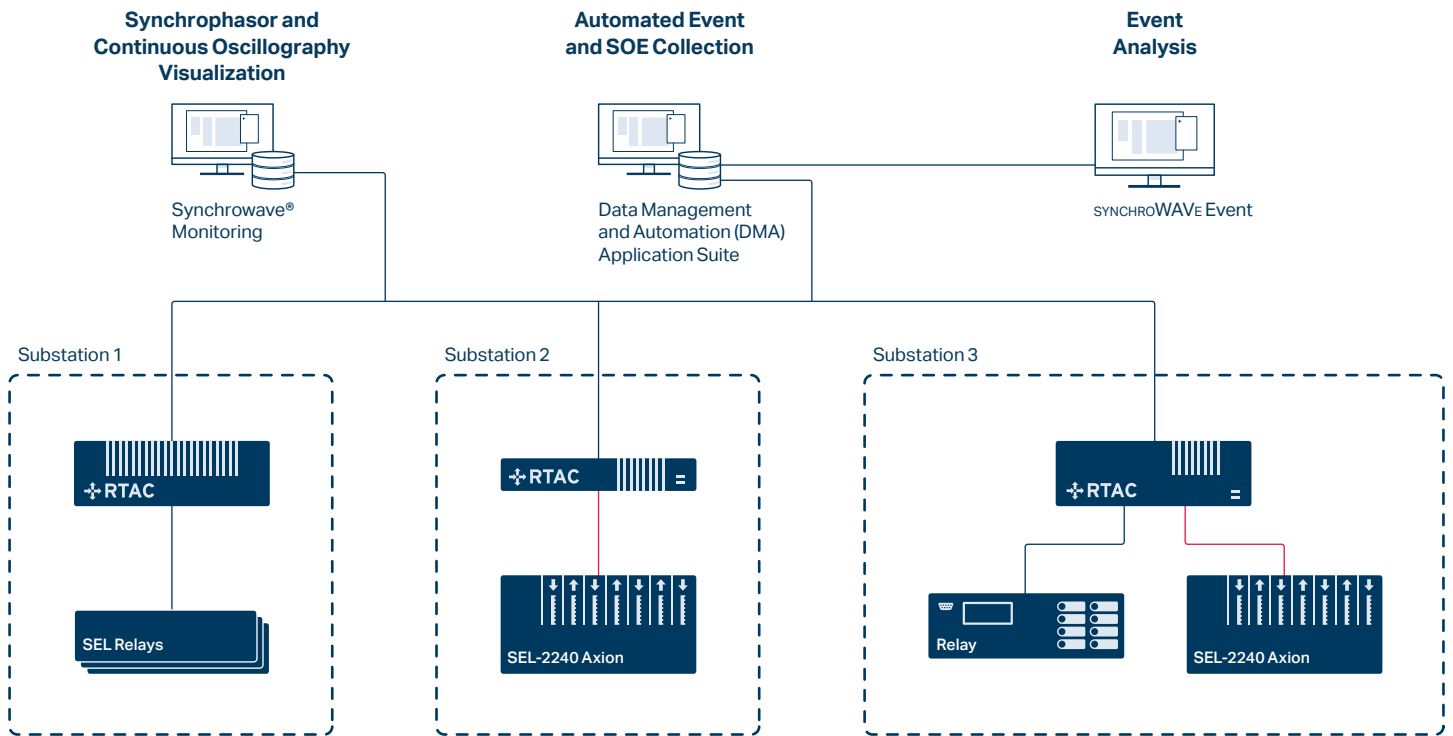

Distributed Energy Resource (DER) Control System

Use the RTAC as a DER control system to simplify interconnection control and solve common interconnection issues, such as adapting for varying cloud cover, nonresponsive inverter controls, and unexpected voltage excursions. The SEL Grid Connect DER control system contains pre-engineered function blocks for controlling the point of common coupling (PCC) between the utility grid and a power generation source. Using the pre-engineered control system library helps get renewable projects online sooner than developing custom project-specific controls.

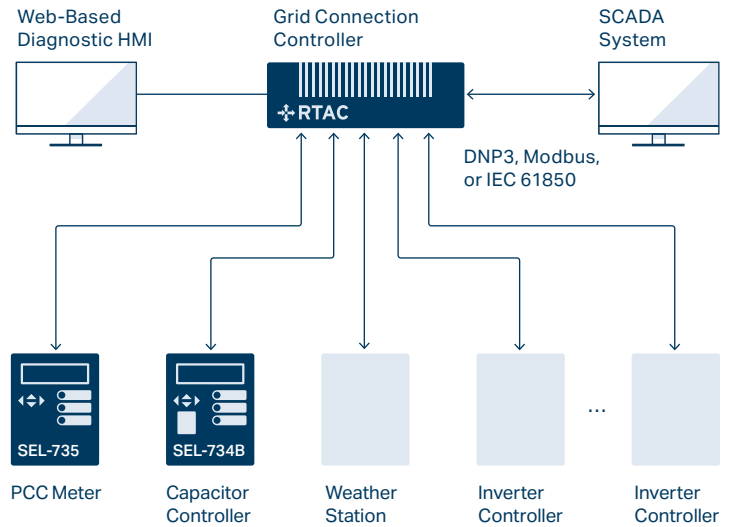

Substation Remote Terminal Unit (RTU)

Deploy the Axion as an RTU to gather digital and analog signals from remote locations. Then, with its variety of industry-standard protocols, you can distribute the data to a central SCADA system or HMI, providing efficient system-wide visibility.

Available input/output modules:

- Digital input module
- Digital output module
- Fast, high-current digital output module
- DC analog input module
- DC analog output module
- AC analog input module

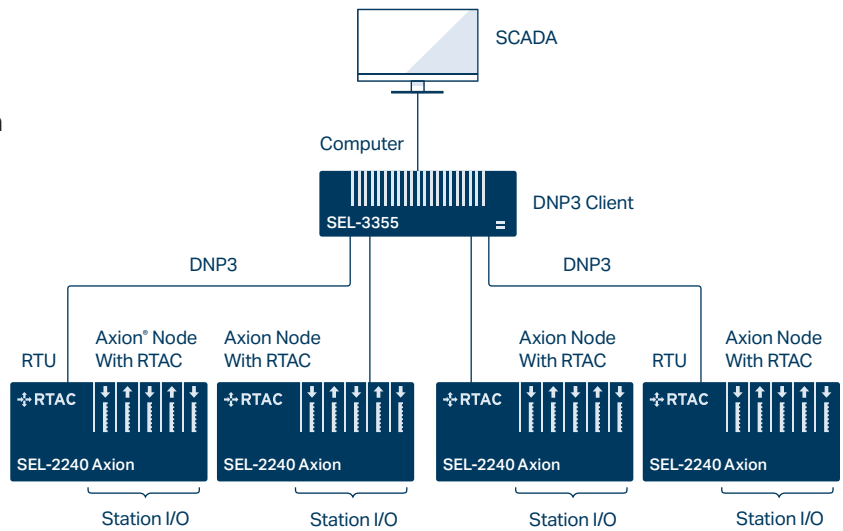

Mini SCADA

As a central controller, the RTAC can communicate between your substations, regulating and managing data for the entire system. The built-in video port brings high-quality control, annunciation, and alarm management via the integrated web HMI. With its advanced processing power, the RTAC is ideal for many demanding applications, such as high-speed automation, synchrophasor processing, and distribution automation as well as integrating data from multiple substations.

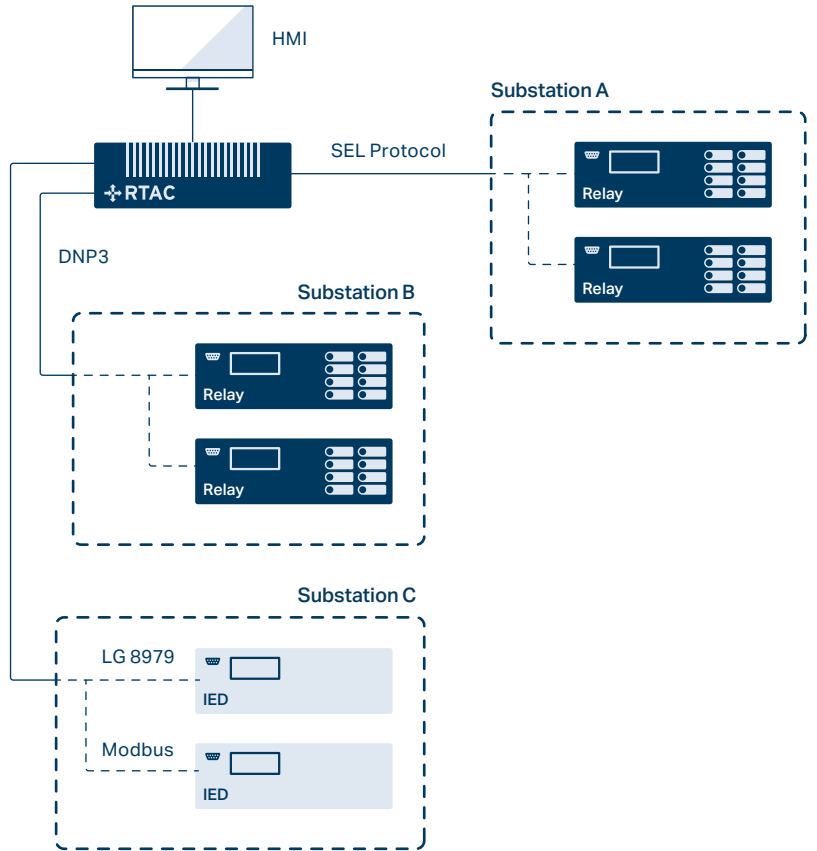

Integrated Video Port for HMI

The RTAC HMI, with advanced HTML5 technology, provides an easy way to visualize data and create custom diagrams to monitor and control your system. The HMI allows authenticated access for multiple users and locations and is viewable from a web browser. The video output port on the RTAC can attach to a monitor, allowing you to quickly and locally view HMI and SOE data without the need for an additional computer.

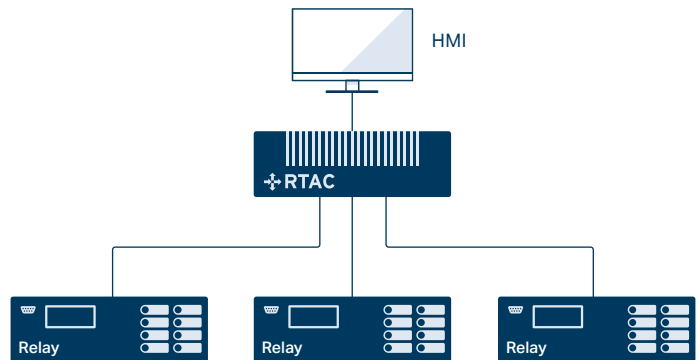

Autosynchronization

With multiple ac metering and I/O modules, the Axion allows you to create advanced, highly scalable autosynchronization systems. Use the Axion to control governors and exciters to automatically synchronize generation with the power system. With synchronized sampling from multiple CT/PT modules, the algorithm for controlling governors and exciters can access the necessary time-aligned voltage magnitude, voltage angle, and frequency measurements in the same Axion system. This allows you to determine the right time to close a breaker in order to synchronize different islands of your power system with precision.

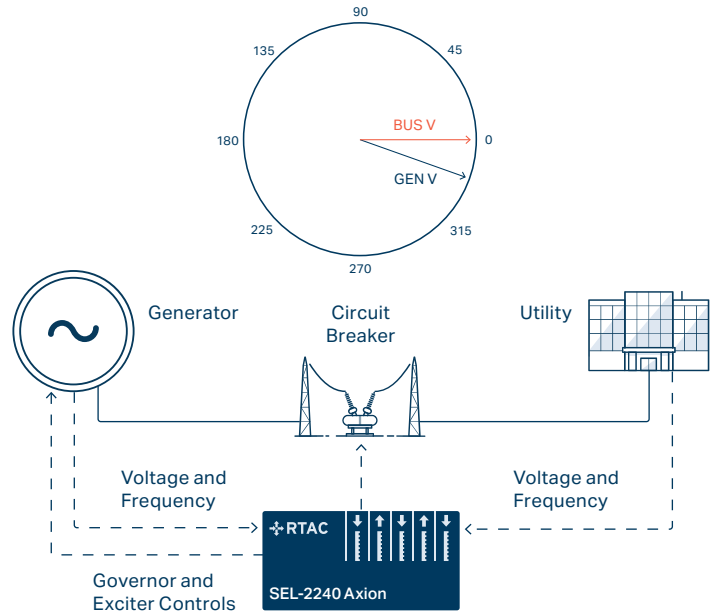

Remote Engineering Access and SCADA Communications

The RTAC offers compact form-factor hardware ideal for small enclosure cabinets. Placing an RTAC in these cabinets can provide continuous monitoring and intrusion detection. Collect, measure, and organize data from both serial and Ethernet IEDs through several standard protocols, such as Modbus, DNP3, and MIRRORRED BITS communications. Use the RTAC with the SEL-651R Advanced Recloser Control for remote engineering access, settings changes, and data collection. Its serial ports, dialup modem, and high-speed network connection provide several ways to gain secure, remote access. In addition, the digital I/O in the RTAC integrates with legacy recloser controllers to provide open/close status.

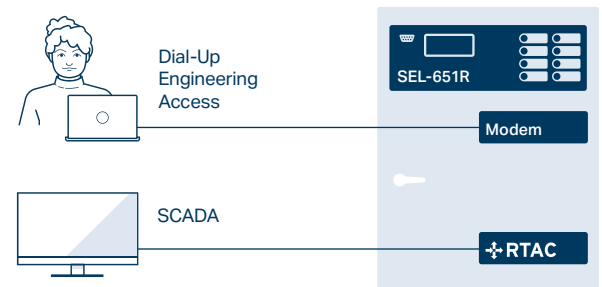

RTAC Platform

The RTAC product family addresses many application requirements based on location, size, and operational demands. By using a common user interface, users only need to learn a single programming software to build projects for any of the different models.

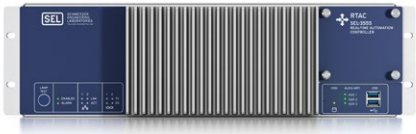

SEL-3555

Our most powerful controller
Ideal for power management, including load shedding, synchrophasor vector processing, and remote or local visualization.



SEL-3560

Compact, fast, and powerful for automation applications with small spaces
Ideal for secure data concentration and protocol conversion

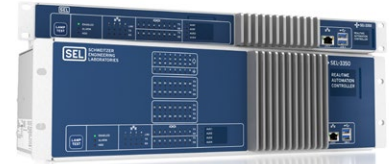

SEL-3350

Flexibility and control for substation automation
Ideal for concentrating information from relays in one central location and converting between protocols to send information to and from SCADA systems.



SEL-3530-4

Powerful control in a compact, half-rack package
Ideal for concentrating information from relays in one central location and converting between protocols to send information to and from SCADA systems.



SEL-3505/3505-3

Economical control with flexible placement
Ideal for a recloser control cabinet and as an inverter control for renewable applications.



SEL-2240 Axion

Modular controller with unparalleled system uptime
Ideal for RTU replacement, as an industrial process controller, and as a phasor measurement unit.

ACSELERATOR RTAC® SEL-5033 Software

One software application for all RTACs

- Configure and deploy projects to the RTAC.
- Develop advanced IEC 61131 logic with the ACSELERATOR RTAC Library Extensions. Use the Horizon® libraries for wide-area monitoring and control.

Download the software at no cost from selinc.com/SEL-5033.

RTAC HMI

Integrated Visualization and Control

The RTAC HMI allows you to visualize your substation electrical power system and includes the benefits of traditional SCADA and HMI packages. The web-based user interface allows one or more authenticated users to interface with customized HMI screens in a client-free environment. You get local or remote HMI access with the built-in web server, and fast information retrieval and display with the advanced HTML5 technology. Communication is performed via Hypertext Transfer Protocol Secure (HTTPS) web sessions. The RTAC HMI uses ACSELERATOR Diagram Builder™ SEL-5035 Software, allowing you to quickly and easily design an integrated substation visualization and control system.

Visualize data over a defined period of time for trending and alarming purposes, both at the time of design and at run time. In addition, when you enter the IP address of the RTAC, all tags from the currently loaded ACSELERATOR RTAC project will be automatically imported into Diagram Builder. This allows you to quickly design your custom HMI screens, load new HMI files into the RTAC, and view the HMI from any web browser on the network. You can also use the RTAC HMI to control devices, including opening breakers or switches and turning devices on or off.

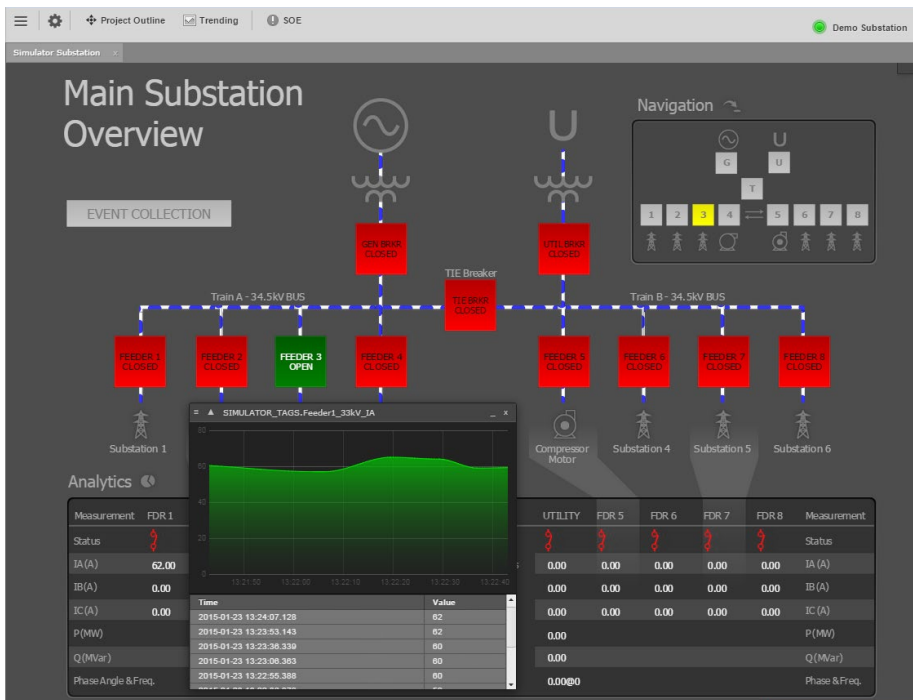

RTAC Family Comparison

Features	SEL-3505 RTAC	SEL-3505-3 RTAC	SEL-2240 Axion With SEL-2241 Module	SEL-3530-4 RTAC
Processor	333 MHz		533 MHz	
RAM	512 MB		1 GB	
Storage	2 GB			
Operation Temperature Range	-40° to +85°C (-40° to +185°F)			
Graphical Web-Based HMI	N/A		Viewing and control via web browser	
Display Ports	N/A			
Power Supply Options	Single		Redundant	Single
Power Supply Voltages	12/24 Vdc or 24/48 Vdc		120/240 Vac, 125/250 Vdc; and/or 24/48 Vdc	120/240 Vac, 125/250 Vdc; 48/125 Vdc, 120 Vac; or 24/48 Vdc
Ethernet Ports	2			
Serial Ports	4	3	4	
Size/Mounting	Surface or DIN-rail mount		5U rack/panel or surface mount (10-slot, 4-slot, and dual 4-slot)	1U half-rack/panel, surface, or DIN-rail mount
Digital and Analog Inputs/Outputs	1 digital output/ 1 digital input	3 digital outputs/ 8 digital inputs	Various I/O modules available	1 digital output/ 1 digital input

SEL-3350 With RTAC Configuration	SEL-3555 RTAC	SEL-3560S RTAC	SEL-3560E RTAC
1.6 GHz Atom quad-core	2.0 GHz Xeon quad-core		
8 GB	8 to 16 GB		
30 to 7,680 GB			
-40° to +85°C (-40° to +185°F)	-40° to +75°C (-40° to +167°F)		-40° to +60°C (-40° to +140°F)
Viewing and control via web browser; integrated video			
1 DisplayPort	1 DisplayPort; 1 DVI/VGA port; 2 DVI-D ports		
Single (1U); redundant: SEL-9325 (3U)	Redundant: SEL-9331	Single (external): SEL-9331	Single (internal): SEL-9331
125/250 Vdc or 120/240 Vac, 48/125 Vdc or 120 Vac; or 24/48 Vdc	125/250 Vdc or 120/240 Vac; LV 48 Vdc		
5	2 standard: 4 per PCI card (up to 2 cards supported)	2	2 standard: 4 per PCI card (up to 1 card supported)
16 (standard)/48 (3U)	8 standard: 6 per PCI card (up to 3 additional cards supported)	2	8 standard: 6 per PCI card (up to 1 additional card supported)
1U or 3U rack/panel mount	3U rack/panel mount	Surface mount	
1 universal input/1 Form C digital output—alarm contact (standard); 24 digital inputs and 8 digital outputs (3U)	1 Form C digital output—alarm contact		

SEL SCHWEITZER ENGINEERING LABORATORIES

Making Electric Power Safer, More Reliable, and More Economical
+1.509.332.1890 | info@selinc.com | selinc.com

© 2025 by Schweitzer Engineering Laboratories, Inc.
PF00328 • 20250102

