

SEL-651RA

Recloser Control



Powerful and cost-effective recloser control for 14-pin applications

- Advanced recloser protection capabilities support coordinated high-speed fault isolation and restoration.
- Arc Sense™ technology, distributed energy resource (DER) point of common coupling, and second-harmonic blocking extend recloser capabilities.
- Support for Ethernet protocols and interfaces improves integration into distribution automation systems.
- Six voltage inputs support measurements on both sides of the recloser.
- Plug-and-work operation, EZ settings, and template storage streamline installation and configuration.



Functional Overview

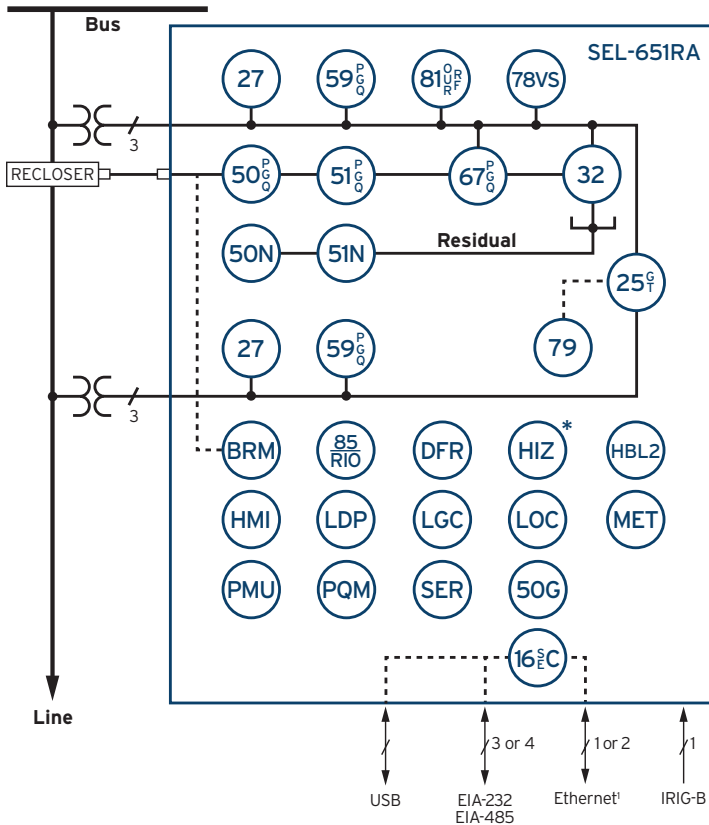

ANSI NUMBERS/ACRONYMS AND FUNCTIONS

16 SEC	Access Security (Serial, Ethernet)
25 (G,T)	Generator/Intertie Synchronism Check
27	Undervoltage
32	Directional Power
50G	Best Choice Ground
50N	Neutral Overcurrent
50 (P,G,Q)	Overcurrent (Phase, Ground, Negative Sequence)
51 (P,G,Q)	Time Overcurrent (Phase, Ground, Negative Sequence)
51N	Neutral Time Overcurrent
59 (P,G,Q)	Overvoltage (Phase, Ground, Negative Sequence)
67 (P,G,Q)	Directional Overcurrent (Phase, Ground, Negative Sequence)
78VS	Vector Shift
79	Autoreclosing
81 (O,U,R)	Frequency (Over, Under, Rate)
81RF	Fast Rate-of-Change of Frequency
85 RIO	SEL MIRRORED BITS® Communications
DFR	Event Reports
HIZ	SEL Arc Sense Technology (AST)*
HMI	Operator Interface
LGC	SELogic® Control Equations
MET	High-Accuracy Metering
PMU	Synchrophasors
PQM	Voltage Sag, Swell, and Interruption
SER	Sequential Events Recorder

ADDITIONAL FUNCTIONS

BRM	Breaker Wear Monitor
HBL2	Second-Harmonic Blocking
LDP	Load Data Profiling
LOC	Fault Locator

¹Copper or fiber-optic

*Optional feature

Compatible With Popular Reclosers

The SEL-651RA Recloser Control works with traditional 14-pin reclosers for complete plug-and-work capability. The interface is designed and tested to exceed the IEC 62271-111/IEEE C37.60 standard. Certificates for the Eaton (Cooper) NOVA and G&W Viper-S reclosers are available at selinc.com/SEL-651RA.

G&W

Viper-S

Viper-G

Other Reclosers

Joslyn TriMod 300R

NOVA Auxiliary Powered

CXE

RE

RVE

RXE

VSA

VSO

VWE

VWVE 27

VWVE 38X

WE

WVE 27

WVE 38X

GVR*

*When equipped with interface module.



Key Features

14-Pin Plug-and-Work Compatibility

The powerful SEL-651RA control provides plug-and-work compatibility for many 14-pin applications. Adapters are available to facilitate retrofit mounting and cabinet installation without drilling holes or modifying the frame.

EZ Settings and Template Storage

EZ settings provide a simple user interface that works well for many basic applications. For more flexibility, Design Templates allow you to make a custom interface. You can store the templates on the control so you always have the one you need.

High-Impedance Fault Detection

SEL AST detects many high-impedance faults and downed conductors while maintaining secure protection. Integrating AST into the SEL-651RA puts high-impedance fault detection out on the feeder, reducing the likelihood of an undetected fallen conductor.

Intertie Protection

Use the SEL-651RA to interconnect microgrids and DERs to area electric power systems. It meets and exceeds the requirements for use at a point of interconnection or point of common coupling, per IEEE 1547-2018.

Advanced Communications Interfaces and Protocols

Easily integrate the SEL-651RA into SCADA or distribution automation systems. Both EIA-232 and EIA-485 serial ports are available as well as two metallic or one or two fiber Ethernet ports. Protocols include DNP3, Modbus, IEC 61850, and the Parallel Redundancy Protocol (PRP). PRP is an Ethernet-based protocol that provides seamless network failover and is available on SEL-651RA recloser controls with dual copper or dual fiber Ethernet ports. A front USB port provides high-speed local access for loading settings or downloading reports.

Six Voltage Inputs

The SEL-651RA measures the voltage on both sides of the recloser, making it especially valuable in autonomously controlled distribution automation schemes. The low-energy analog (LEA) inputs allow the use of integrated voltage sensors, which reduce costs and simplify installation.

Advanced Protection

The SEL-651RA includes many advanced protection features that ensure secure and reliable operation, including second-harmonic blocking and rate-of-change-of-frequency (ROCOF) controls. These features minimize undesired operations associated with transformer inrush current and provide faster decoupling of distributed generation on a feeder.

Secure Ethernet Communications

Use Media Access Control Security (MACsec) to enhance the existing cybersecurity of the SEL-651RA and reduce operation and maintenance expenses. MACsec secures Ethernet traffic (except IEC 61850 GOOSE and PRP) between an SEL-651RA and SEL-3622 or Key Server MACsec-enabled routers/radios, providing confidential communication and maintaining message integrity between devices. Key management is automated via the MACsec Key Agreement (MKA) to simplify commissioning and improve the overall user experience.



Product Overview

Corrosion-resistant painted aluminum cabinet provides a maintenance-free enclosure.

USB port provides fast local access.

EIA-232 front serial port provides local access.

Navigation controls make information readily accessible.

Optional software-programmable tricolored LEDs for improved status indication.

Programmable control pushbuttons and configurable labels for ease of operation.

Standard three-point latch for improved physical security.



Two standard EIA-232 ports and an EIA-485 port provide several communications options. (EIA-232 ports are hidden from this view.)

64 SELogic variables replace traditional panel switches with 32 latching, 16 local, and 32 remote control points.

Standard multisession Modbus TCP and DNP3 and optional IEC 61850 easily integrate with existing systems.

Standard dual copper Ethernet ports or the optional dual fiber Ethernet ports allow communication between devices and provides redundancy. An optional single fiber Ethernet port is also available.

Standard single PT voltage input and optional six voltage inputs with PT and LEA options easily integrate with many reclosers.

Built-in synchrophasor measurements for real-time electrical quantities.

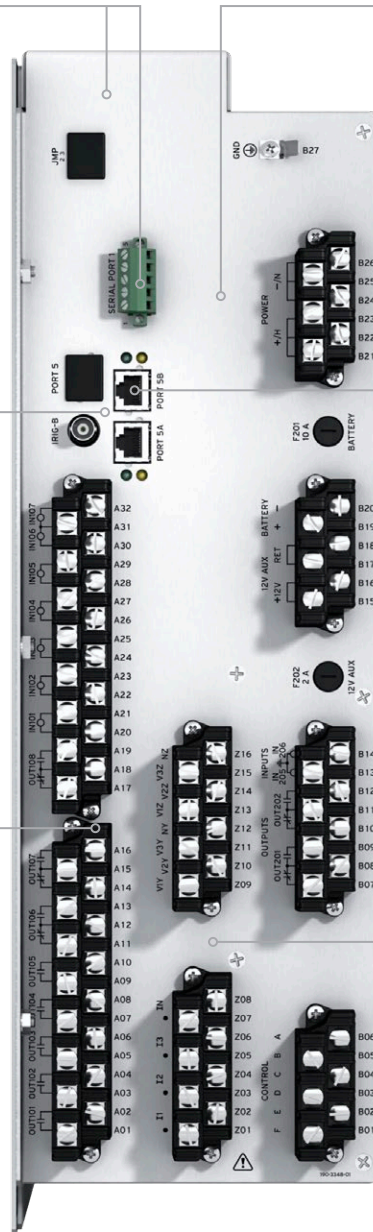

Applications

Advanced Control for Distribution Automation

Automatically reconfigure your distribution system with the SEL-651RA to isolate faults and restore service quickly to impact the fewest customers. The SEL-651RA is an integral part of SEL's distribution automation solution—DNA® (Distribution Network Automation). With DNA, you can improve reliability and increase operational efficiency while reducing operating costs.

Automatic Network Reconfiguration (ANR) improves service reliability by isolating permanently faulted segments and quickly restoring service to nonfaulted segments. You can apply the SEL-651RA in various systems, either with or without communication between devices.

The SEL-651RA includes logic and counter options to detect loss-of-voltage conditions that indicate upstream recloser openings. You can change the settings sensitivity in intermediate recloser controls before the tie recloser is closed. Reclose shot counting or time coordination let you determine the faulted segment.

The SEL-651RA includes up to six voltage inputs to monitor voltages on both sides of the recloser, ensuring safe and secure ANR.

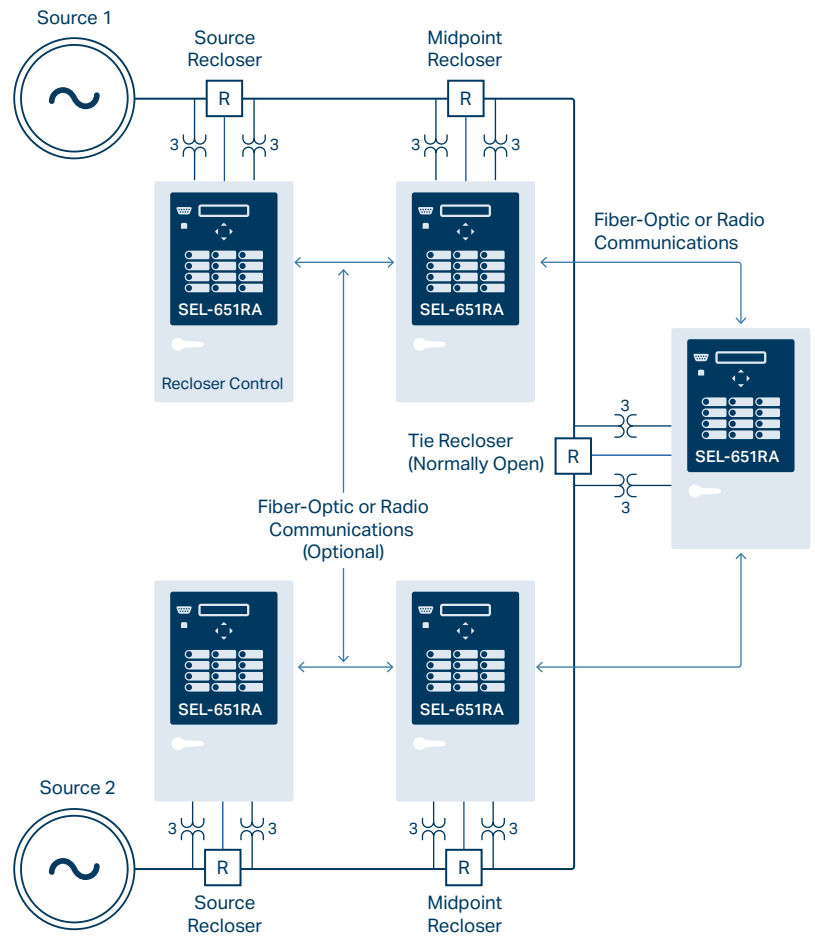

Communicate directly with any SEL-651RA via serial or Ethernet communications without the need of a field remote terminal unit (RTU).



High-Impedance Fault Detection

High-impedance faults, such as downed conductors on poorly conductive surfaces, create fault current levels that are too low for conventional overcurrent protection elements to detect. The SEL-651RA with AST detects many high-impedance faults while maintaining secure protection.

The SEL-651RA with AST is easy to understand, set, and test. It includes straightforward protection algorithms with two sensitivity levels and a test mode.

Coordination

When AST is present in multiple devices on a single feeder, the relay or control closest to a high-impedance fault detects the stronger signal and isolates the fault to coordinate with other relays or controls on the system. This coordination isolates only the faulted segment of the line and minimizes the number of customers affected by a high-impedance fault. You can use communications between relays to improve AST protection performance on complex feeder arrangements or in the case of feeder reconfiguration.

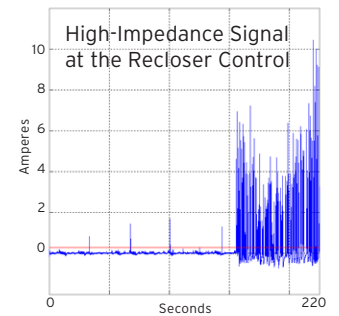
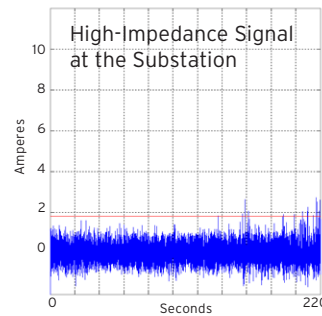
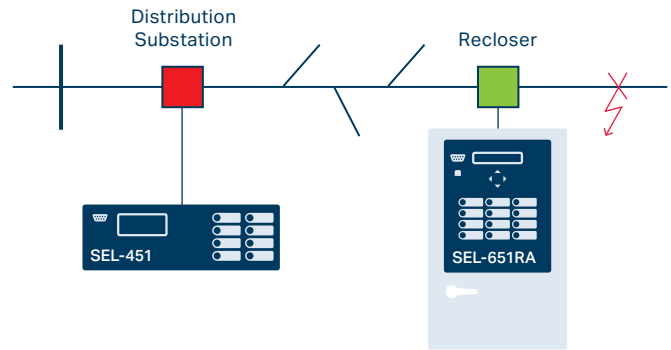

The SEL-651RA offers high-impedance fault detection, providing improved detection by being closer to the fault.



Replace Traditional Recloser Controls

Quickly replace traditional recloser controls by selecting from a wide variety of available features and accessories. The SEL-651RA includes familiar EZ settings and the ability to accommodate retrofit applications that use Design Templates. Only settings such as minimum trip pickup, curve type, and recloser interval are necessary when using the EZ access level.

The SEL-651RA is a replacement for several third-party and legacy SEL recloser controls, including:

- Direct physical replacement for the SEL-351R-4.
- Direct replacement using the available mounting bracket for the SEL-351R-0, -1, and -2 as well as the Cooper Form 3, 3A, 4, 4A, 4C, 4D, FXA, and FXB controls.
- Direct connection replacement for the Eaton (Cooper) Form 5 and Form 6 controls.

Apply Autosource Transfer Schemes

The SEL-651RA lets you maintain reliable power for critical loads that require dual-feeder service. Using SEL MIRRORRED BITS communications technology between recloser controls, you can make intelligent operation decisions to bring nonfaulted loads back online. MIRRORRED BITS lets you communicate securely and share recloser status, source status, and other logic information between SEL-651RA Recloser Controls.

Customize the return-to-normal action by incorporating a synchronism check for parallel source return or break-before-make when source voltages are not in phase.

Protect DER Interconnections

Use the SEL-651RA to interconnect microgrids and DERs to area electric power systems. Together, the SEL-651RA and recloser provide a compact pole-top solution for interconnecting DERs with overhead distribution lines. Utilities, consultants, microgrid owners, and DER owners can use this solution at the point of common coupling, as defined in IEEE 1547-2018. The SEL-651RA works with microgrid controllers and generator control systems.

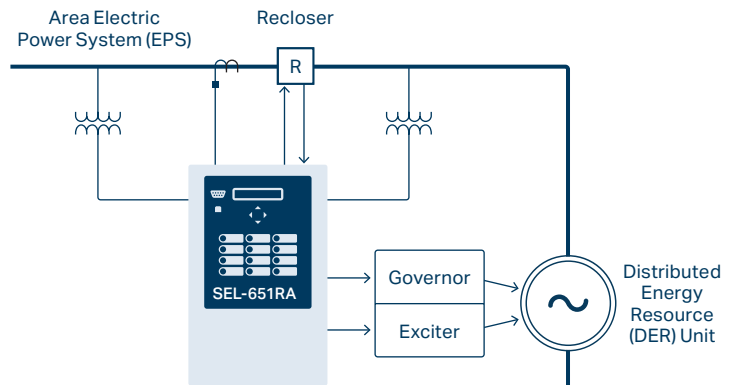

Typical utility and DER interconnection.

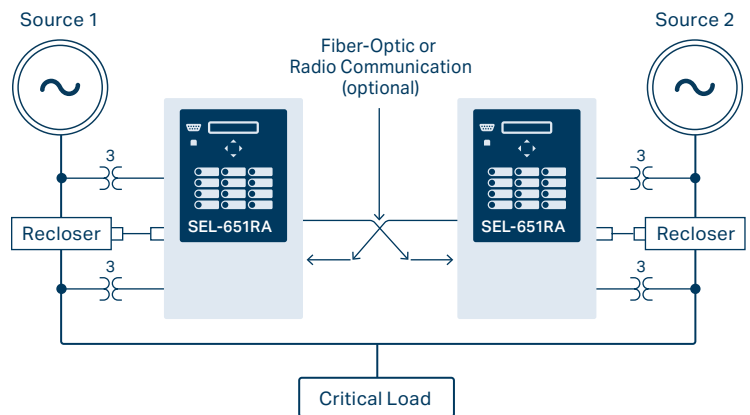

Use the SEL-651RA as part of an autosource transfer scheme.

Multilayer Security

Configure the SEL-651RA with MACsec to obtain point-to-point security. Add IPsec to the SEL-3622 to obtain end-to-end network security.

IPsec

Add the SEL-3622 Security Gateway for encrypted IPsec VPN access to the SEL-651RA. The SEL-3622 also acts as a firewall and protects against malware with exe-GUARD® allowlist antivirus. The SEL-3622 authenticates users, manages passwords, logs and reports Syslog events, and has physical security sensors to alert on unauthorized access to the SEL-651RA cabinet.

MACsec

The SEL-651RA utilizes MACsec to secure Ethernet traffic (except IEC 61850 GOOSE and PRP), providing integrity, authenticity, replay prevention, and optional confidentiality to communications. MACsec is a nonroutable, “hop-by-hop” cryptographic protocol that protects Ethernet frames starting at the data link layer (OSI Layer 2).

When enabled, MACsec establishes a secure, bidirectional link between connected devices after security keys have been exchanged and verified. Key management is automated with MKA, which provides capabilities including network discovery, mutual authentication, key management, parameter management, and bounded delay. Commissioning can be further simplified with a configuration mode that autopopulates the necessary settings.

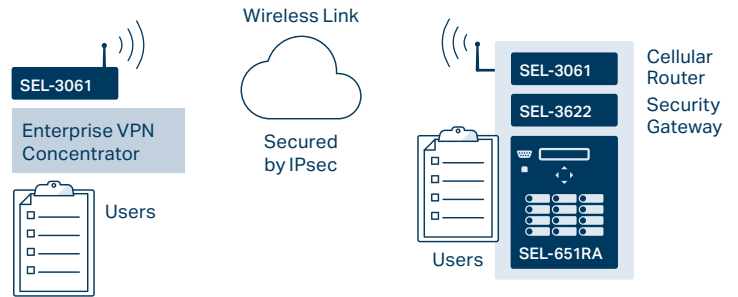

Integration

Quickly integrate the SEL-651RA into Ethernet or serial communications networks with standard DNP3 and Modbus protocols or optional IEC 61850. The SEL-651RA comes standard with three independent EIA-232 serial ports, one EIA-485 port, one USB port, and two metallic Ethernet ports for external communication. Optional alternatives for the Ethernet ports include single fiber and dual-redundant fiber ports. PRP is available as a standard option on SEL-651RA recloser controls with dual-Ethernet copper or dual-Ethernet fiber ports. PRP is an Ethernet-based redundancy protocol that provides seamless network failover for systems such as electrical substations.

Using an Ethernet connection, you can upload firmware to the SEL-651RA in less than a minute. You can also download 60-cycle-length, 128-samples-per-cycle event reports.

The Ethernet ports provide access for local and remote engineering, SCADA, real-time protection and control, loop restoration, islanding detection, blocking, and fast bus tripping schemes. The SEL-651RA works well in distribution automation systems, including loop schemes and high-speed, peer-to-peer systems.

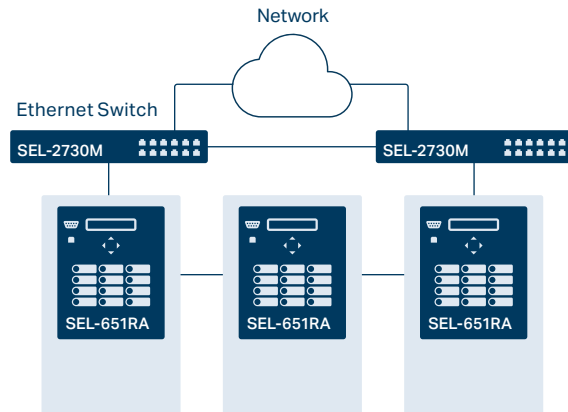

Communications Protocols

MIRRORED BITS communications

IEEE C37.118 synchrophasors

IEC 61850 GOOSE*

IEC 61850 MMS*

Modbus TCP

Modbus RTU

Telnet

DNP3 Serial

DNP3 IP

Web server

Simple Network Time Protocol (SNTP)

FTP

SEL Fast Messages

ASCII

IRIG-B

PRP

Communications Media

10/100BASE-T Ethernet

10/100BASE-FX Ethernet*

EIA-232 serial

EIA-485 serial

USB Type B

BNC (IRIG-B)

*Optional feature

ACSELERATOR® Software

Save time and simplify settings with ACSELERATOR QuickSet® SEL-5030 Software. QuickSet lets you:

- Develop settings offline with a menu-driven interface and direct links to the instruction manual for easy help reference. You can speed up installation by copying existing settings files and modifying application-specific items.
- Quickly commission SEL-651RA Recloser Controls. You can use settings templates to customize the interface so field personnel see only the settings they need when working with the recloser control. Sample templates for common applications are available on the SEL website.
- Access your settings template anytime. You can store templates on the SEL-651RA and retrieve them for easy access in the field.
- See more prefault and post-fault data with high-resolution 60-cycle-length event reports at 128 samples per cycle to identify the root cause of problems or make decisions about system design.

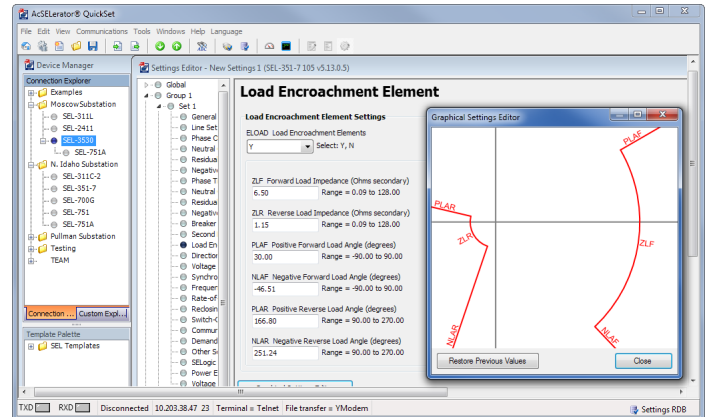

View system data and streamline relay settings with QuickSet.

Monitoring and Metering

The SEL-651RA measures signal distortions up to the 16th harmonic for each current and voltage input. The recloser control calculates total harmonic distortion and provides the value as a control element for alarming and tripping.

You can reduce the installed cost of feeder control panels by avoiding separately mounted metering devices. SEL high-accuracy metered quantities include root-mean-square (rms) phase voltages, currents, and power.

Customize Your SEL-651RA

SEL offers a variety of accessories to optimize recloser control efficiency and operation. You can create a customized solution to meet your application needs. Some popular accessories include a cabinet heater, an accessory shelf, fuse blocks, and prewired connectors. Many accessories are available for factory installation or as field upgrade kits. Listed below are some of the accessories available to create a robust recloser solution.



SEL-2401 Satellite-Synchronized Clock

Provide precise time for synchrophasor measurements with the SEL-2401, which has ± 100 nanosecond accuracy for automatically updated time.



SEL-3031 Serial Radio Transceiver

Combine three serial ports into one radio, allowing up to three different connections and protocols to operate simultaneously. The spread-spectrum, frequency-hopping radio transmits data in the license-free 900 MHz ISM band, providing an economical communications path or backup communications system.



SEL-3061 Cellular Router

The SEL-3061 is a secure wireless communications solution designed for critical applications. For electric utilities, the router provides connectivity to devices like recloser controls, motor-operated switches, capacitor banks, voltage regulators, substations, and much more. The combination of serial and Ethernet ports provides application flexibility, and using public networks with secure tunneling makes installation easy without sacrificing security.



SEL-3622 Security Gateway

A router, VPN endpoint, and firewall device, the SEL-3622 can perform secure and proxy user access for the SEL-651RA. The SEL-3622 helps create a user audit trail through strong, centralized, user-based authentication and authorization to the recloser control. The SEL-3622 secures your control system communications with a stateful deny-by-default firewall, strong cryptographic protocols, and logs for system awareness.



Door Position Indication Switch

Monitor the position of the enclosure door, and send an alarm to SCADA when the cabinet has been opened. You can use this simple security feature to detect and respond to unwanted intruders.



SEL Fault Indicators and Sensors

Team the SEL-651RA with the SEL-FT50 and SEL-FR12 Fault Transmitter and Receiver System or SEL faulted circuit indicators to provide fault location information for more intelligent protection decisions and to reduce restoration times.

SEL-651RA Specifications

General Specifications

Compatible Reclosers	G&W Electric: Viper-G and Viper-S Other reclosers: CXE, RE, RVE, RVX, VSA, VSO, VWE, VWVE, WE, WVE, and NOVA Auxiliary Powered GVR (when equipped with interface module)
Current Inputs	IA, IB, and IC: 1 A nominal IN: 0.2 A nominal
AC Voltage Inputs	300 V maximum (PT) 8 V maximum LEA (IEEE C37.92) Eaton (Cooper) internal LEA (37 V) Lindsey SVM I LEA (200 V, 1 M Ω)
Frequency and Phase Rotation	60/50 Hz system frequency ABC or ACB phase rotation
Communications Ports	EIA-232 (3 ports) USB Type B EIA-485 Ethernet port: Dual 10/100BASE-T (RJ-45 connectors) Single 100BASE-FX (LC connector) (optional) Dual 100BASE-FX (LC connectors) (optional)
Communications Protocols	SEL, IEC 61850 (optional), PRP (for dual-Ethernet copper or fiber models), MIRRORRED BITS communications, Modbus, DNP3, ASCII protocols, SNTP, IEEE C37.118 (synchrophasors), built-in web server
DER Interconnection	IEEE 1547-2018
Power Supply	120–240 Vac or 125–250 Vdc Rated range: 85–264 Vac or 100–350 Vdc
Weight	<75 lb without accessories
Battery Reserve	\geq 8 hours at -40°C and \geq 25 hours at $+25^{\circ}\text{C}$ (16 Ah standard) \geq 27 hours at -40°C and \geq 83 hours at $+25^{\circ}\text{C}$ (40 Ah optional)
Operating Temperature	Relay module: -40° to $+85^{\circ}\text{C}$ (-40° to $+185^{\circ}\text{F}$) Batteries: -40° to $+80^{\circ}\text{C}$ (-40° to $+176^{\circ}\text{F}$) Entire SEL-651RA unit: -40° to $+55^{\circ}\text{C}$ (-40° to $+131^{\circ}\text{F}$)

SEL SCHWEITZER ENGINEERING LABORATORIES

Making Electric Power Safer, More Reliable, and More Economical
+1.509.332.1890 | info@selinc.com | selinc.com

© 2024 by Schweitzer Engineering Laboratories, Inc.
PF00341 • 20240617

