

SEL-3360



Rugged, versatile computing platform for utility and industrial applications

- Configurable as a Blueframe® application platform or an industrial computer running a Microsoft Windows or Linux OS.
- Powerful and compact surface-mount model with an Intel Xeon quad-core 2.0 GHz or 2.8 GHz processor.
- Durable design with a broad operating temperature range from -40° to $+75^{\circ}\text{C}$ (-40° to $+167^{\circ}\text{F}$).
- High-quality single-level cell (SLC) SSDs and error-correcting code (ECC) memory.
- Worldwide ten-year warranty, local technical support, and no-charge diagnostic and repair services.





Compact Design, Powerful Computation

Not every work environment has ideal conditions. Your equipment might endure anything from electro-magnetic interference, shock, and vibration to extremely hot or cold temperatures.

That's why we designed the SEL-3360—a powerful computing platform with an Intel Xeon quad-core processor that operates reliably in the harshest conditions.

A broad operating temperature range ensures the SEL-3360 will survive where other computers fail. The fanless design provides passive cooling with two mounting options. The standard chassis option passes heat to the ambient air through aluminum fins. For installations inside metal enclosures,

the conduction-cooled mounting option conducts heat directly to the wall of the enclosure, which is cooled by the outside air.

The compact size allows you to install the SEL-3360 in tight spaces. Between the two models, the SEL-3360S provides a smaller footprint, while the SEL-3360E offers room for expansion with a larger chassis, supporting up to two additional adapter cards and an internal power supply.

With exceptional reliability, SEL computing platforms operate with little or no maintenance, making them ideal for unattended operation. The SEL-3360 is a computer you can depend on to operate with the highest reliability in critical industrial processes.

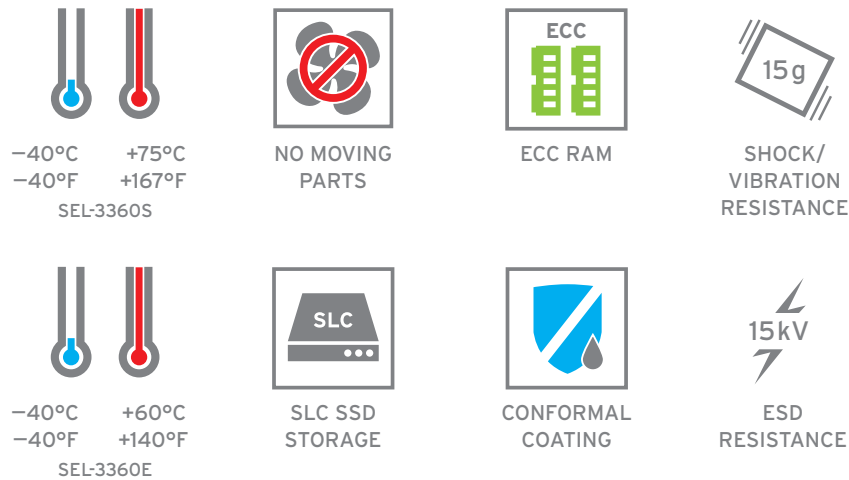

Performance and Durability

High-Performance Computing Power—SEL-3360 computing platforms have a sixth-generation Xeon processor (quad-core 2.0 GHz or 2.8 GHz). You can choose two SSDs for the two-slot drive bay from the SLC, pseudo-SLC (pSLC), and 3D triple-level cell (TLC) drive options for a maximum of 8 TB of storage. Up to 64 GB of ECC system memory provides ample computing resources for your most demanding applications.

Designed for Harsh Environments—SEL-3360 computing platforms can withstand temperatures ranging from -40° to +75°C (-40° to +167°F), up to 15 kV of electrostatic discharge (ESD), fast transients, high electromagnetic interference, vibration, and shock up to 15 g.

All SEL computing platforms conform to or exceed IEC 61850-3, IEEE C37.90, IEEE 1613, and IEC 60255 standards.

Reliable, Available, and Serviceable

SEL computing platforms are similar to server-class computers with respect to RAS—reliability, availability, and serviceability. Industrial computer systems need to always be available and easy to service when necessary. SEL computing platforms satisfy these requirements in the following ways.

Reliability—We design, manufacture, and test every SEL computing platform in house. Our computing systems are exceptionally reliable. In addition, SEL computing platforms are backed by a ten-year, no-questions-asked warranty.

Availability—Intel vPro Active Management Technology (AMT) maximizes system availability and minimizes operational outages in the event of a system failure. Our computing platforms also feature SEL SysMon software and a watchdog timer to attempt automatic recovery when a failure occurs.

Serviceability—AMT lets you view diagnostic logs for evaluation and service even when the OS is shut down. You can reboot into another OS for diagnostics or to batch install software and then bring the system back online, all remotely. Additionally, SysMon logs computing platform events specific to the installed system to aid in faster recovery. AMT's KVM-over-IP feature can provide hands-on help and guidance from an expert back at the central office, which can speed up serviceability.

SEL-3360S Overview

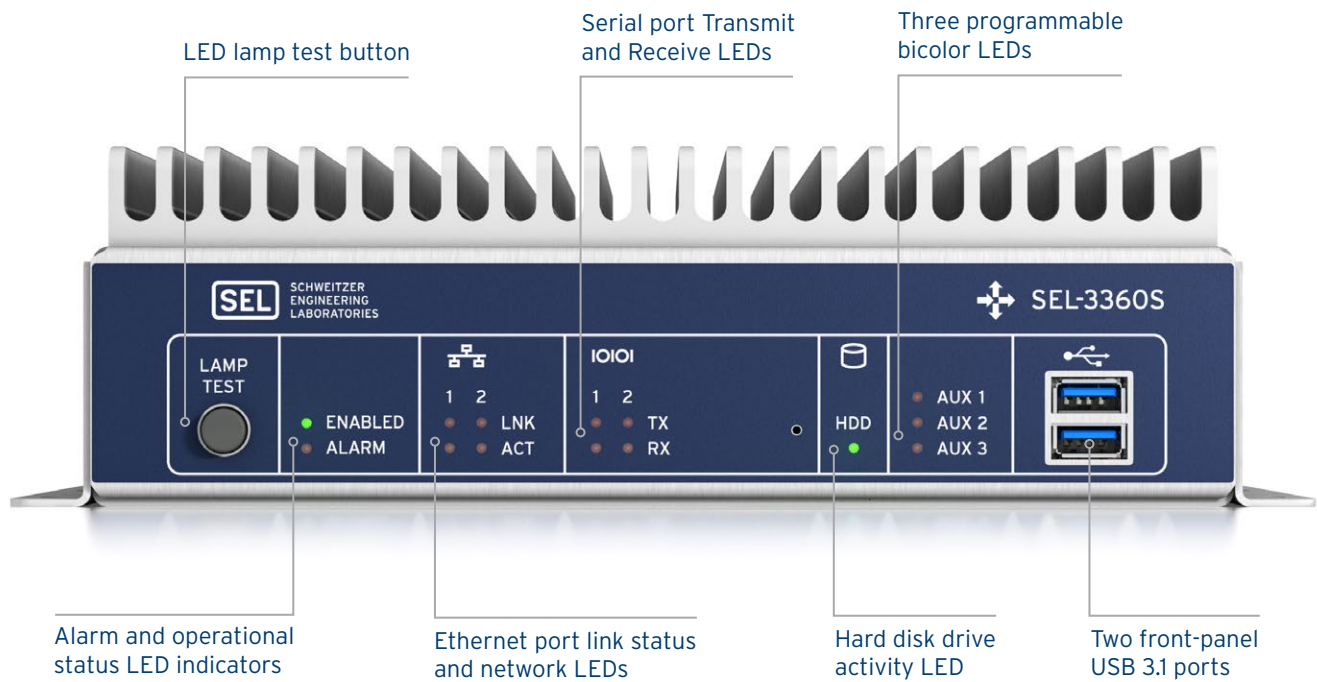

Product Physical Dimensions

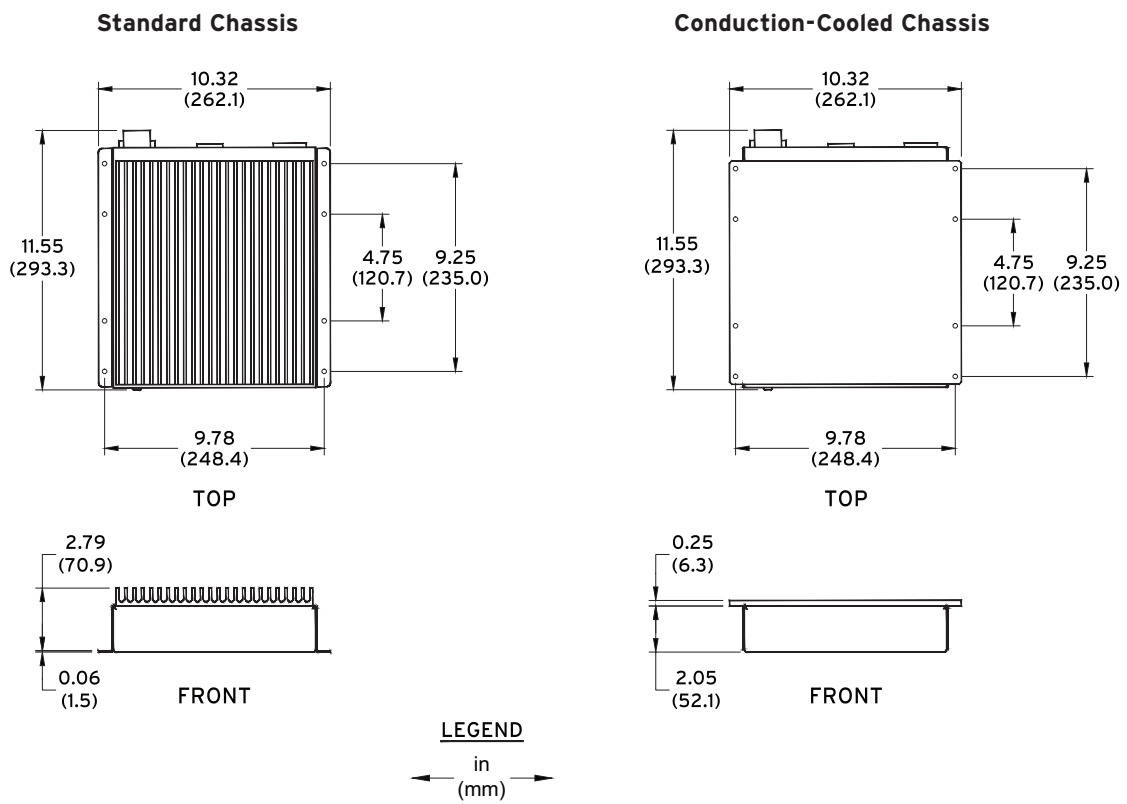

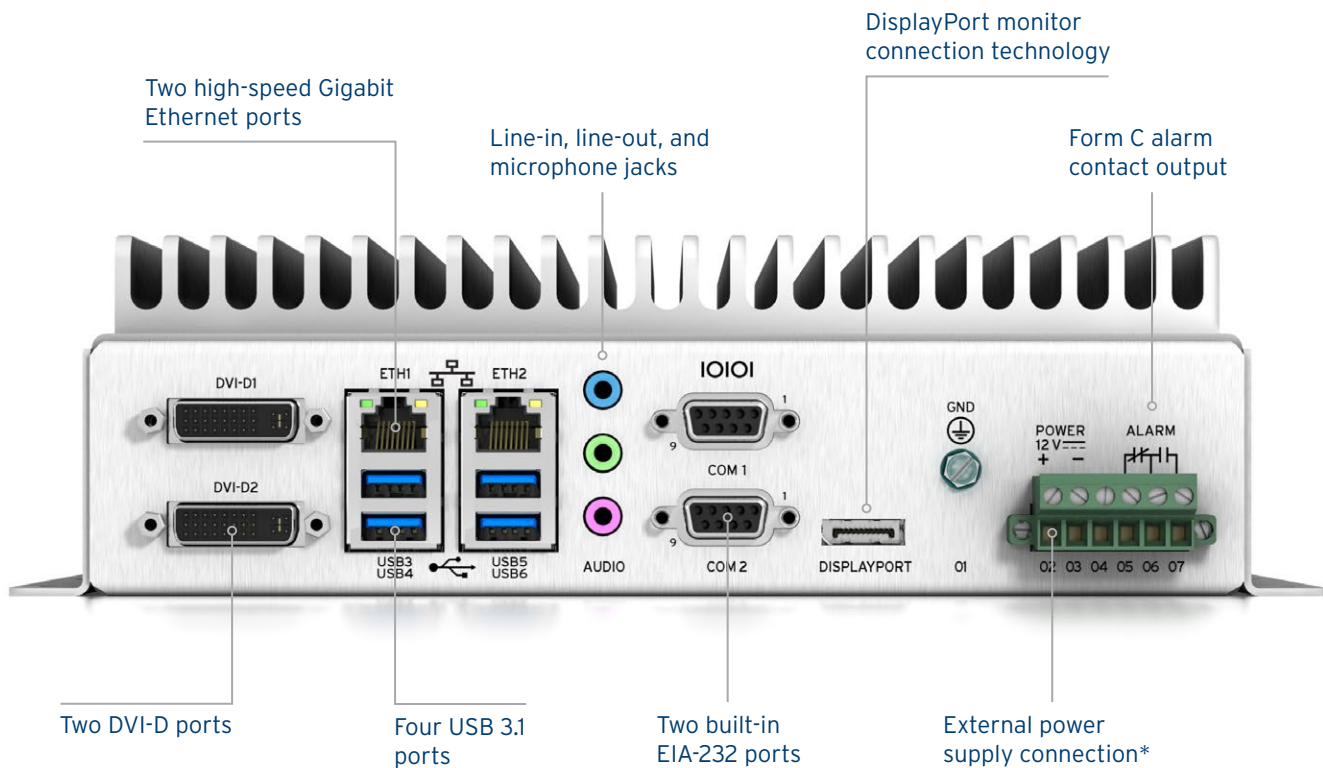

Ports

Video

Intel HD Graphics P530 Controller

Independent display outputs: 3
 DVI-D maximum resolution: 1920 × 1200 @ 60 Hz
 DisplayPort 1.2 maximum resolution: 4096 × 2160 @ 60 Hz

Audio

IDT 92HD91 HD Audio Codec

3 analog 3.5 mm TRS jacks: line input, line/headphone output, microphone input

Intel Display Audio

DVI-D and DisplayPort connectors; digital audio bitstream output

USB

4 rear-panel, 2 front-panel ports
 USB 3.1-compliant; 2,000 mA current limit each

Ethernet

2 rear-panel copper RJ45 ports
 ETH1: Intel WGI219LM, 10/100/1000 Mbps
 ETH2: Intel WGI210IT, 10/100/1000 Mbps

Serial

2 EIA-232 ports, DB-9 connectors, 300 to 115,200 bps; 5 V port power, 500 mA available on Pin 1

SEL-3360E Overview

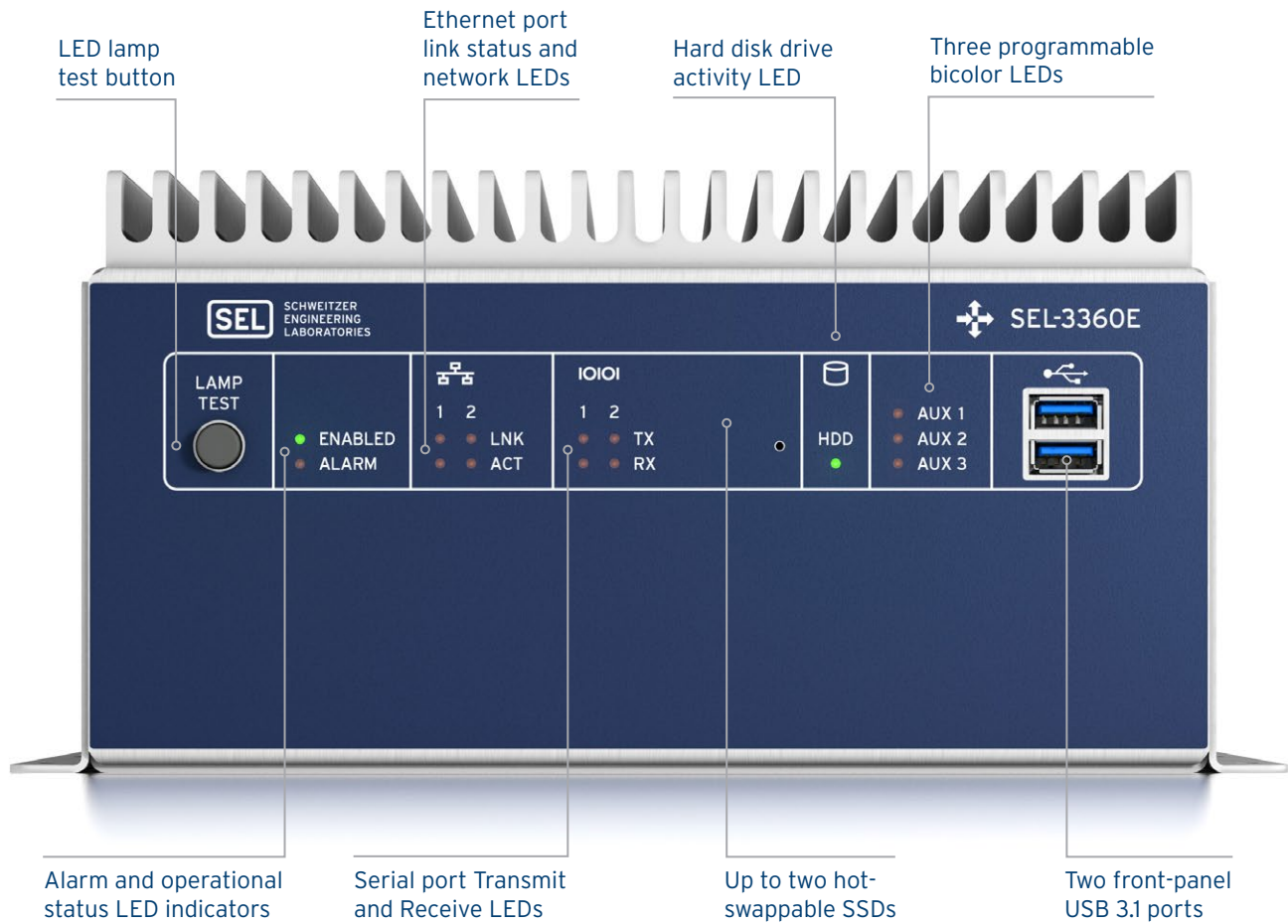

Product Physical Dimensions

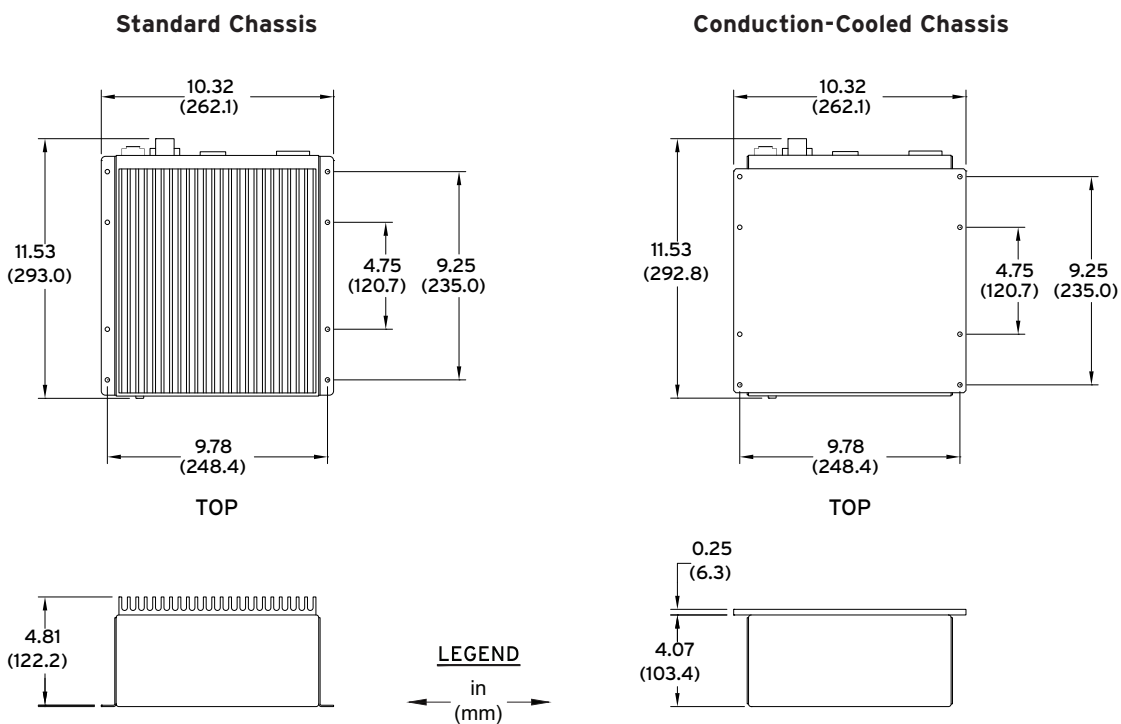

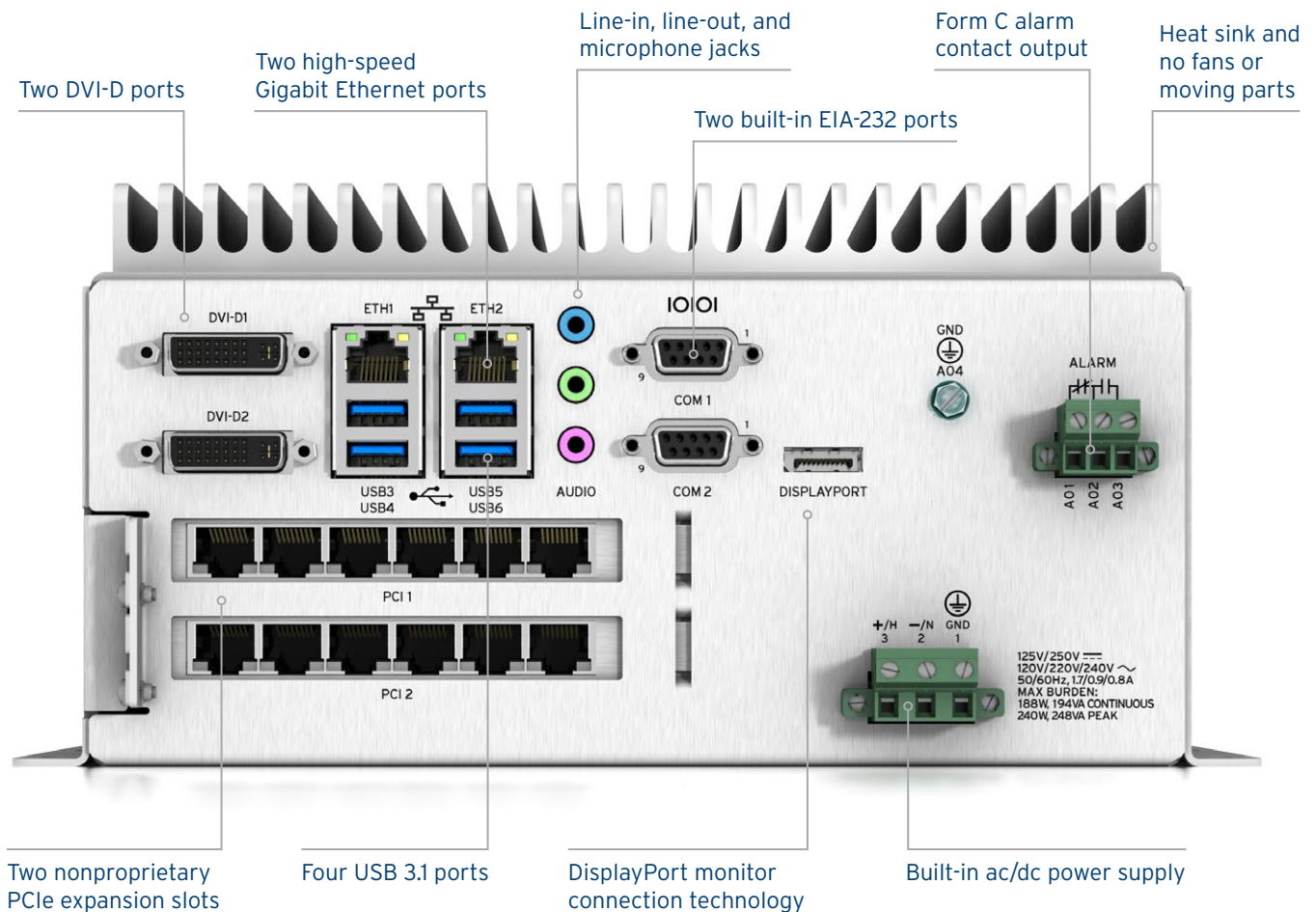

Ports

Video	Intel HD Graphics P530 Controller Independent display outputs: 3 DVI-D maximum resolution: 1920 × 1200 @ 60 Hz DisplayPort 1.2 maximum resolution: 4096 × 2160 @ 60 Hz
Audio	IDT 92HD91 HD Audio Codec 3 analog 3.5 mm TRS jacks: line input, line/headphone output, microphone input Intel Display Audio DVI-D and DisplayPort connectors; digital audio bitstream output
USB	4 rear-panel, 2 front-panel ports USB 3.1-compliant; 2,000 mA current limit each
Ethernet	2 rear-panel copper RJ45 ports ETH 1: Intel WG1219LM, 10/100/1000 Mbps ETH2: Intel WG1210IT, 10/100/1000 Mbps
Serial	2 EIA-232 ports, DB-9 connectors, 300 to 115,200 bps; 5 V port power, 500 mA available on Pin 1
Integrated Power Supply	125–250 Vdc or 120–240 Vac high-voltage input, or 48 Vdc low-voltage input
Expansion	Two PCI/PCIe expansion slots, enabling you to customize the system I/O to meet your application needs. Choose from a selection of SEL PCI/PCIe cards, or install a third-party expansion card.

Applications

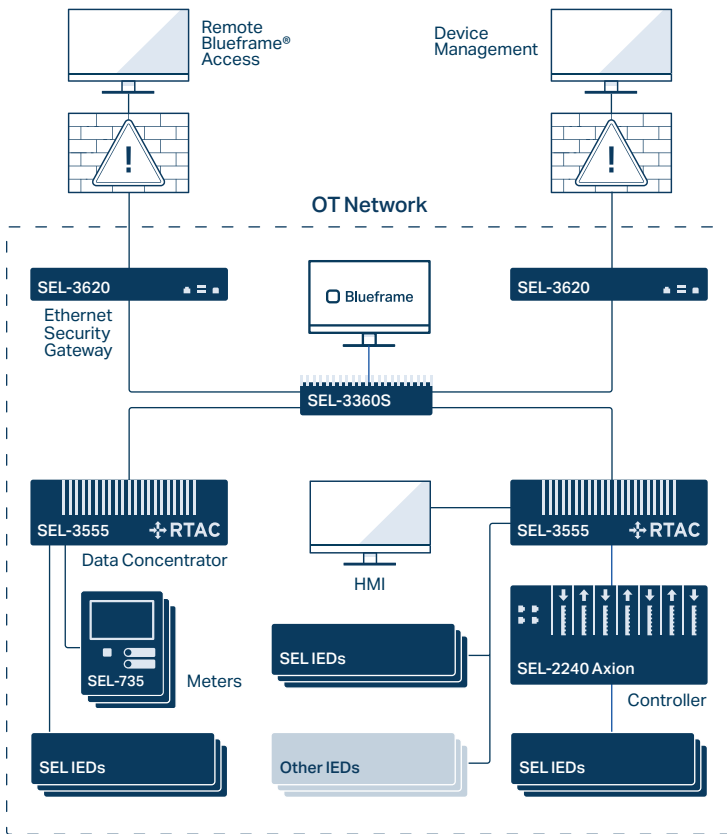

Blueframe

Improve your power system operational technology (OT) network management, simplify security patches, and ensure availability using the SEL Blueframe application platform. You can configure SEL computing platforms (SEL-3350, SEL-3355, and SEL-3360) with Blueframe to manage and operate SEL containerized applications, like Data Management and Automation (DMA) applications.

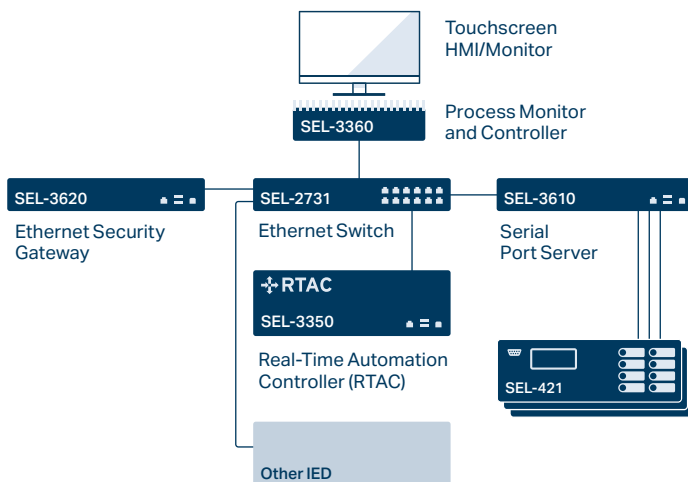

Remote Engineering Workstation

Choose an SEL computing platform as your engineering workstation, and get a reliable and robust system suitable for the harshest environments. You can view and change IED settings, view report and event data, and gain easy access to diagram drawings and documents onsite. With the Microsoft Windows Remote Desktop tool or Secure Shell (SSH), you can access the engineering workstation remotely and securely. For out-of-band access, you can use the AMT KVM-over-IP feature.

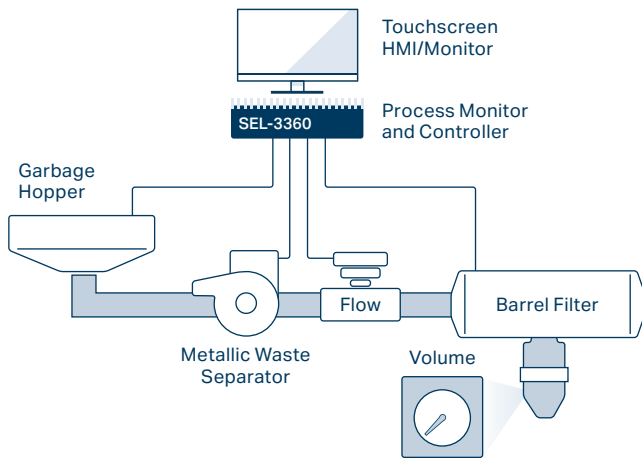

Industrial Process Control Platform

SEL computing platforms are perfect candidates for any industrial control system requiring the power of a rugged, reliable, highly available computer. SEL computing platforms allow you to implement a control system with your choice of SCADA software. With ample communications ports (serial or Ethernet), the SEL-3360 is also ideal for distributed control systems.

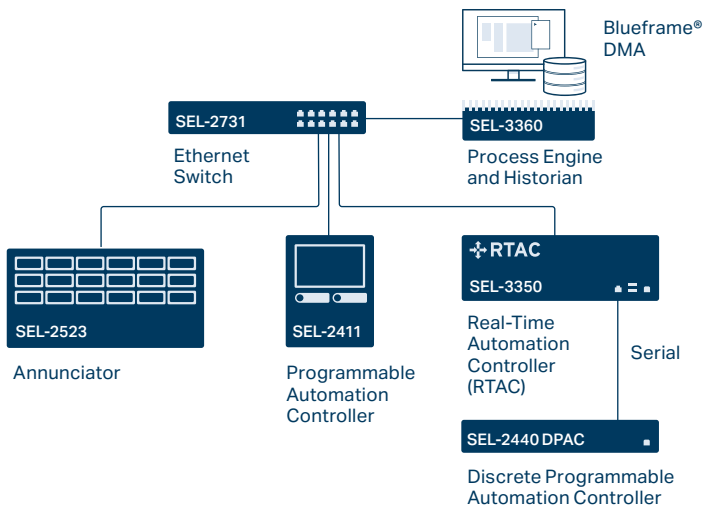

Data Archiver

Leverage the RAID capabilities of the SEL-3360 to store and access your critical data. You can host your favorite historian software for large data analysis projects or use an SEL computing platform with the DMA application suite to create a disturbance recording and monitoring system.

Accessories

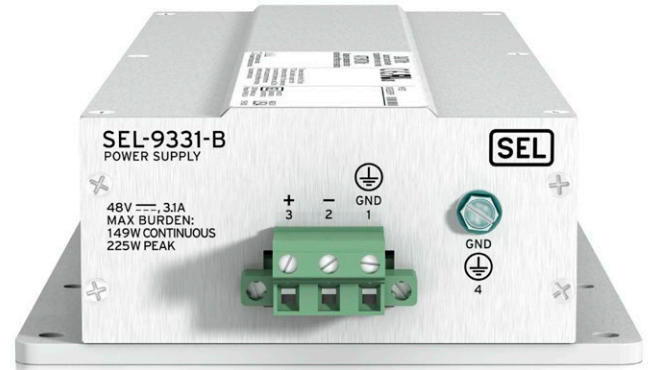

Power Supplies

The SEL-9331 Power Supply is a high-output +12 Vdc power supply designed for SEL computing platforms and powerful enough to meet the needs of many other applications. Capable of producing 11 A of continuous current from -40° to $+85^{\circ}\text{C}$ and 17 A of maximum current, the SEL-9331 can provide ample power in environments where many supplies cannot.

The SEL-3360E integrates one SEL-9331 internally. You can order the supply with either three-terminal Euro-style or C14 coupler input connectors. Three mounting options are available: panel-mount plate, horizontal DIN rail, and vertical DIN rail.



SSDs and Mounting Sled

SLC SSDs provide the most robust and reliable storage. With no moving parts and the highest write cycle count of any mass solid-state storage media, they provide more uptime and a higher return on investment (ROI). Wide operating temperature ranges ensure that these drives will continue to work in the harshest environments. All SLC drives are covered by the SEL ten-year worldwide warranty. All pSLC and 3D TLC SSDs are covered by a five-year warranty.

The drives come with mounting sleds already installed for easy insertion into the SEL-3360. You can also purchase spare mounting sleds. The sleds are compatible with 2.5-inch SATA hard-drive mounting holes.

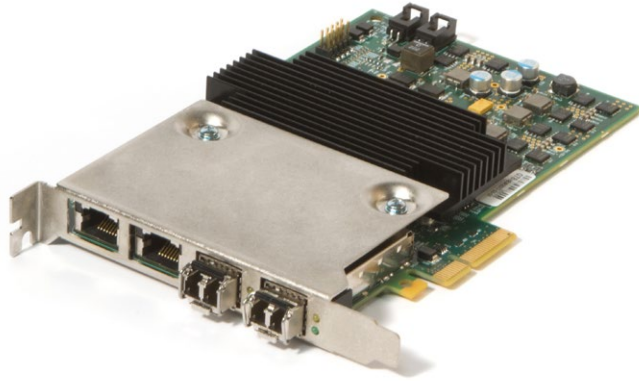

SEL-3390E4 Ethernet Network Adapter Card

Compatible with the SEL-3360E, the SEL-3390E4 is a 10/100/1000 Mbps PCIe expansion card that is designed, built, and tested for use in harsh industrial and substation environments. The SEL-3390E4 provides a wide operating temperature range and immunity to ESD, shock, and vibration. You can also order it with conformal coating for corrosion immunity. The SEL-3390E4 complies with the PCIe form factor and works with other PCIe-compliant computers and controllers.

Choose one SEL-3390E4 PCIe x4 industrial PCIe Ethernet card for four additional independent Gb ports. You can select all copper, all LC fiber, or a mix of two copper and two fiber ports. The fiber ports use small form-factor pluggable (SFP) modules to support either single-mode or multimode operation at various transmit power levels on a per-port basis.

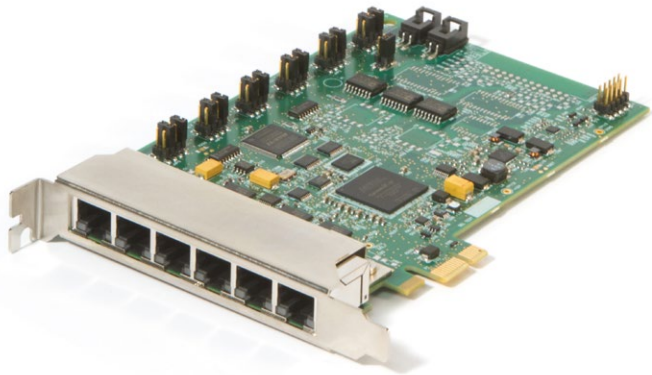

SEL-3390S8 Serial Adapter Card

Compatible with the SEL-3360E, the SEL-3390S8 is a PCIe-compliant expansion card that makes use of RJ45 ports instead of DB-9 ports for maximum serial I/O density. You can choose up to two SEL-3390S8 Cards for an additional twelve EIA-232/485 serial ports. The SEL-3390S8 supports IRIG-B input and output.



SEL-3390T Time and Ethernet Adapter Card

Compatible with the SEL-3360E, the SEL-3390T is a PCIe expansion card that adds precise time synchronization and distribution functionality to SEL computing platforms. The SEL-3390T allows these devices to directly synchronize with IRIG-B sources or over Ethernet using the hardware time-stamped Precision Time Protocol (PTP). It provides two Ethernet ports, one BNC input, and one BNC output for IRIG-B so you can source time from IRIG-B and Ethernet devices. The SEL-3390T complies with the PCIe form-factor and can also be installed in other PCIe-compliant computers and controllers.

SEL-3360 Specifications

General

Supported Operating Systems

SEL OSs:
RTAC[†]
Blueframe*

Supported Third-Party OSs:
Microsoft Windows 8
Microsoft Windows 10*
Microsoft Windows Server*
Red Hat Enterprise Linux (RHEL)
CentOS Linux
Ubuntu LTS Linux
SUSE Linux
VMware ESXi

CPU

SEL-3360E and SEL-3360S
Intel Xeon E3-1505L Quad-Core
Speed: 2.0 GHz base, 2.8 GHz turbo
Cache: 1 MB L2, 8 MB L3

SEL-3360S Only
Intel Xeon E3-1505M Quad-Core
Speed: 2.8 GHz base, 3.7 GHz turbo
Cache: 1 MB L2, 8 MB L3

RAM

Xeon E3: 4, 8, 16, 32, or 64 GB DDR4 ECC
PC4-17000 (2,133 MHz)

Chipset

Intel CM236 Express Chipset

Mass Storage

1 internal drive bay with up to two 2.5" SSDs, 32–1,920 GB each
SATA II 3.0 Gb/s; RAID level 0, 1; hot-swap support

Adapter Card Slots

Two PCIe expansion slots. PCI 1: x1 slot; PCI 2: x4 slot (SEL-3360E only)

Real-Time Clock/Calendar

Battery type: IEC No. BR2335 Lithium
10 years with power (2 years without power)

BIOS

AMI UEFI

Trusted Platform Module (TPM)

Infineon SLB 9670AQ TPM 2.0

Storage Temperature Range

–40° to +85°C (–40° to +185°F)

[†]Available via SEL-3533 RTAC Conversion Kit.

*Orderable as a factory-installed option.

System Operating Temperature Range

SEL-3360S
With E3-1505L CPU:
–40° to +75°C (–40° to +167°F)
With E31505M CPU:
–40° to +60°C (–40° to +140°F)

SEL-3360E
With E3-1505L CPU:
–40° to +60°C (–40° to +140°F)

Time-Code Input/Output

Base
IRIG-B input on COM1

Optional
SEL-3390S8 Serial Adapter Card
RJ45 serial port; demodulated IRIG-B (TTL-compatible); output generated from IRIG-B input or SEL-3355 clock

SEL-3390T Time and Ethernet Adapter Card
Synchronize with IRIG-B sources or over Ethernet using the hardware time-stamped PTP. Provides one BNC input, one BNC output for IRIG-B, and two Ethernet ports.

Intel AMT

Intel AMT 11.0

Input Power

SEL-3360S
Input: 12 Vdc
Voltage range: 10–16.6 Vdc
Typical burden: 25 W
Max. burden: 144 W (cold startup)
Peak inrush: 15 A
SEL-9331: External (optional)

SEL-3360E
Input: 125–250 Vdc, 120–240 Vac, or 48 Vdc
Typical burden: 48 W
Max. burden: 157 W (cold startup)
Peak inrush: 15 A
SEL-9331: Internal

Certifications

ISO 9001: Designed, manufactured
RoHS
CE: CE Mark EMC Directive, Low-Voltage Directive
UL, cUL: 61010-1, C22.2 No. 61010-1
RCM
FCC: 47 CFR 15B, Class A
UKCA



Making Electric Power Safer, More Reliable, and More Economical
+1.509.332.1890 | info@selinc.com | selinc.com

© 2024 by Schweitzer Engineering Laboratories, Inc.
PF00356 • 20240313

