

SEL-734B

Capacitor Bank Control

Field Reference Guide

20231206

 **SCHWEITZER ENGINEERING LABORATORIES, INC.**



© 2015–2023 by Schweitzer Engineering Laboratories, Inc. All rights reserved.

All brand or product names appearing in this document are the trademark or registered trademark of their respective holders. No SEL trademarks may be used without written permission. SEL products appearing in this document may be covered by U.S. and Foreign patents.

Schweitzer Engineering Laboratories, Inc. reserves all rights and benefits afforded under federal and international copyright and patent laws in its products, including without limitation software, firmware, and documentation.

The information in this document is provided for informational use only and is subject to change without notice. Schweitzer Engineering Laboratories, Inc. has approved only the English language document.

This product is covered by the standard SEL 10-year warranty. For warranty details, visit selinc.com or contact your customer service representative.

PM734B-03

Table of Contents

List of Tables	iii
List of Figures	v
Preface	vii
Section 1: Overview	
Introduction	1.1
SEL-734B Front Panel	1.2
SEL-734B Rear Panel.....	1.3
Enclosure Front	1.5
Section 2: Field Connections to the Enclosures	
Overview	2.1
Connections to Full-Size Enclosures.....	2.1
Connections to Compact Enclosures	2.8
Section 3: Installing the Enclosure	
Overview	3.1
Grounding the Enclosure	3.1
Pole-Mounting the Full-Size and Compact 7-Pin Enclosures	3.2
Connecting Full-Size Enclosures to a Control Power Transformer and Switches	3.4
Connecting Full-Size Enclosures to the Sensors	3.5
Mounting Socket-Based Enclosures.....	3.5
Connecting Socket-Based Enclosures to a Control Power Transformer and Switches.....	3.6
Section 4: Configuring the SEL-734B	
Overview	4.1
Record the Part Number and Serial Number of the Device	4.1
Establish SEL Communication Between PC and the SEL-734B	4.1
Change Passwords.....	4.5
Section 5: Working With the SEL-734B Design Template Settings	
Overview	5.1
Enclosure Model Features	5.1
Read Settings From the SEL-734B	5.2
Save Configuration Settings to the PC Hard Drive	5.3
Settings Window	5.3
Section 6: Commissioning	
Overview	6.1
Front-Panel Menu Structure	6.1
Verify the Measurements	6.2
Close and Open the Capacitor Bank From the Front Panel.....	6.3
Close and Open the Capacitor Bank From the QuickSet HMI	6.3
View the Sequential Events Recorder	6.4
Validate SER	6.5
Troubleshooting and Common Problems	6.6
Full-Size Enclosure Design Templates	6.7

Section 7: Maintenance

Appendix A: Field Reference Guide Versions

Appendix B: Compact Socket-Based Enclosure Revisions

Appendix C: Installation Examples

Full-Size Enclosures With the Combined Sensor Connector	C.1
Full-Size Enclosures With Individual Sensor Connectors.....	C.3
Compact 7-Pin Enclosures.....	C.6
Compact Socket-Based Enclosures	C.8

Appendix D: Cable Drawings

Control Cables for Full-Size Enclosures With the Combined Sensor Connector	D.1
Sensor Cables for Full-Size Enclosures With the Combined Sensor Connector.....	D.5
Power Supply/Neutral Sensor Cables for Full-Size Enclosures With Individual Sensor Connectors.....	D.8
Control Cables for Full-Size Enclosures With Individual Sensor Connectors	D.9
Sensor Cables for Full-Size Enclosures With Individual Sensor Connectors	D.11
Control and Sensor Cable for Compact 7-Pin Connectorized Enclosures.....	D.12

Appendix E: Compact Enclosure Drawings

Compact 4-Jaw Socket-Based Enclosure	E.2
Compact 6-Jaw Option A Socket-Based Enclosure	E.4
Compact 6-Jaw Option B Socket-Based Enclosure.....	E.6
Compact 7-Pin Military Connector Enclosure.....	E.8
Compact 7-Pin Terminal Block Connector Enclosure	E.10
Full-Size Combined Sensor Connector Enclosure.....	E.12
Full-Size Individual Sensor Connector Enclosure.....	E.14

Appendix F: Accessories

Compact Enclosure Accessories.....	F.1
Full-Size Enclosure Accessories.....	F.1

List of Tables

Table 2.1	Pinout of 19-Pin Control Connector J1 for Full-Size Enclosures With the Combined Sensor Connector	2.2
Table 2.2	Control Cables for Full-Size Enclosures With the Combined Sensor Connector.....	2.3
Table 2.3	Pinout of 14-Pin Combined Sensor Connector J2 for Full-Size Enclosures.....	2.3
Table 2.4	Sensor Cables for Full-Size Enclosures With the Combined Sensor Connector	2.4
Table 2.5	Pinout of 19-Pin Control Connector J1 for Full-Size Enclosures With Individual Sensor Connectors	2.5
Table 2.6	Control Cables for Full-Size Enclosures With Individual Sensor Connectors	2.6
Table 2.7	Pinout of 4-Pin Individual Sensor Connectors J3, J4, and J5	2.6
Table 2.8	Sensor Cables for Full-Size Enclosures With Individual Sensor Connectors.....	2.7
Table 2.9	Pinout of Power Supply/Neutral Connector J2 for Full-Size Enclosures With Individual Sensor Connectors.....	2.7
Table 2.10	Power Supply/Neutral Sensor Control Cables for Full-Size Enclosures With Individual Sensor Connectors.....	2.8
Table 2.11	Socket Stab Configurations.....	2.9
Table 2.12	Pinout of Control, Power, and Sensor Cable J1 for 7-Pin Connectorized Enclosure	2.10
Table 2.13	Control and Sensor Cable for the 7-Pin Connectorized Enclosure	2.10
Table 4.1	Default Passwords and Access Levels	4.2
Table 5.1	Control Features of Enclosure Models.....	5.1
Table 6.1	Front-Panel Menu Structure	6.1
Table A.1	Revision History.....	A.1
Table B.1	Compact Socket-Based Enclosure Revision History	B.1

This page intentionally left blank

List of Figures

Figure 1.1	SEL-734B Model Options in Outdoor-Rated Enclosures	1.1
Figure 1.2	SEL-734B Front Panel	1.2
Figure 1.3	Top Label and Rear Panel	1.3
Figure 1.4	24/48 Vdc Power Supply.....	1.4
Figure 2.1	Bottom View of Enclosure With Combined Sensor Connector.....	2.1
Figure 2.2	Bottom View of Enclosure With Individual Sensor Connectors	2.5
Figure 2.3	4- and 6-Jaw Socket Stabs.....	2.8
Figure 2.4	Bottom View of Connectorized Compact Enclosure	2.9
Figure 2.5	Bottom View of Terminal Block Enclosure.....	2.10
Figure 3.1	SEL-734B Required System Grounding	3.2
Figure 3.2	Full-Size Enclosure Mounting Dimensions	3.3
Figure 3.3	Compact 7-Pin Enclosure Mounting Dimensions	3.4
Figure 3.4	Meter Locking Ring for Socket-Based Enclosure.....	3.5
Figure 4.1	Default Serial Communication Parameters	4.2
Figure 4.2	QuickSet HMI Status Window Example	4.3
Figure 4.3	QuickSet HMI Capacitor Bank Control Overview	4.4
Figure 4.4	QuickSet Terminal Status Example	4.5
Figure 5.1	QuickSet Prompt to Read Settings Groups	5.3
Figure 5.2	Design Template View.....	5.4
Figure 5.3	Settings Editor View of a Design Template.....	5.4
Figure 5.4	Settings Editor Views.....	5.5
Figure 6.1	Aliased SER Report in QuickSet HMI.....	6.4
Figure 6.2	Operation Counters on the Rotating Front-Panel LCD.....	6.7
Figure 6.3	Counter Values Obtained Via QuickSet Terminal.....	6.8
Figure 6.4	SELOGIC Counter Equations Settings in the Settings Editor View.....	6.9
Figure C.1	Full-Size Enclosure With Combined Sensor Connector (With a Single Cable for Phase and Neutral Sensors)	C.2
Figure C.2	Full-Size Enclosure With Combined Sensor Connector (Installed With Cooper Junction Box and Separate Neutral Sensor Cable)	C.3
Figure C.3	Full-Size Enclosure With Individual Sensor Connectors (Installed With a Generic Neutral Current Sensor).....	C.4
Figure C.4	Full-Size Enclosure With Individual Sensor Connectors (Installed With a Lindsey Neutral Current Sensor).....	C.5
Figure C.5	Full-Size Enclosure With Individual Sensor Connectors (Installed With a Single Sensor and Generic Neutral Current Sensor).....	C.6
Figure C.6	Compact 7-Pin Connectorized Enclosure	C.7
Figure C.7	Compact 7-Position Terminal Block Enclosure.....	C.8
Figure C.8	Compact 6-Jaw Option A Socket-Based Enclosure Connection Diagram	C.9
Figure E.1	Compact 4-Jaw Socket-Based Enclosure Schematic Diagram	E.2
Figure E.2	Compact 4-Jaw Socket-Based Enclosure Point-to-Point Wiring Diagram	E.3
Figure E.3	Compact 6-Jaw Option A Socket-Based Enclosure Schematic Diagram	E.4
Figure E.4	Compact 6-Jaw Option A Socket-Based Enclosure Point-to-Point Wiring Diagram	E.5
Figure E.5	Compact 6-Jaw Option B Socket-Based Enclosure Schematic Diagram	E.6
Figure E.6	Compact 6-Jaw Option B Socket-Based Enclosure Point-to-Point Wiring Diagram	E.7
Figure E.7	Compact 7-Pin Military Connector Enclosure Schematic Diagram	E.8
Figure E.8	Compact 7-Pin Military Connector Connectorized Enclosure Point-to-Point Wiring Diagram	E.9
Figure E.9	Compact 7-Pin Terminal Block Connector Enclosure Schematic Diagram	E.10
Figure E.10	Compact 7-Pin Terminal Block Connector Enclosure Point-to-Point Wiring Diagram.....	E.11
Figure E.11	Full-Size Combined Sensor Connector Enclosure Schematic Diagram	E.12
Figure E.12	Full-Size Combined Sensor Connector Enclosure Point-to-Point Wiring Diagram.....	E.13
Figure E.13	Full-Size Individual Sensor Connector Enclosure Schematic Diagram.....	E.14
Figure E.14	Full-Size Individual Sensor Connector Enclosure Point-to-Point Wiring Diagram	E.15

This page intentionally left blank

Preface

Overview

The SEL-734B Capacitor Bank Control is based on the SEL-734 Advanced Metering System platform. Devices ship with an outdoor-rated enclosure and are programmed with control strategies specific to each model option.

The *SEL-734B Field Reference Guide* provides a general overview of the SEL-734B and describes the procedures for installation as a capacitor bank control. This guide also provides troubleshooting and testing methods.

The *SEL-734B Data Sheet* details the model options available, the features and control strategies associated with each option, as well as interface options and compatible accessories.

The *SEL-734B Design Template Guides* describe the operation of the specific enclosure model, detail the settings associated with the model option, and contain logical diagrams for developers. Several design templates are available, and each template is compatible with a specific enclosure model.

The *SEL-734 Instruction Manual* details all other features available in the SEL-734 device, including metering, power quality, and communications.

Safety Information

Dangers, Warnings, and Cautions

This manual uses three kinds of hazard statements, defined as follows:

DANGER

Indicates an imminently hazardous situation that, if not avoided, **will** result in death or serious injury.

WARNING





Indicates a potentially hazardous situation that, if not avoided, **could** result in death or serious injury.





CAUTION

Indicates a potentially hazardous situation that, if not avoided, **may** result in minor or moderate injury or equipment damage.

Safety Symbols

The following symbols are often marked on SEL products.

	 CAUTION Refer to accompanying documents.	 ATTENTION Se reporter à la documentation.
	Earth (ground)	Terre

	Protective earth (ground)	Terre de protection
	Direct current	Courant continu
	Alternating current	Courant alternatif
	Both direct and alternating current	Courant continu et alternatif
	Instruction manual	Manuel d'instructions

Safety Marks

The following statements apply to this device.

General Safety Marks

<p>⚠ CAUTION There is danger of explosion if the battery is incorrectly replaced. Replace only with Ray-O-Vac® no. BR2335 or equivalent recommended by manufacturer. See Owner's Manual for safety instructions. The battery used in this device may present a fire or chemical burn hazard if mistreated. Do not recharge, disassemble, heat above 100°C or incinerate. Dispose of used batteries according to the manufacturer's instructions. Keep battery out of reach of children.</p>	<p>⚠ ATTENTION Une pile remplacée incorrectement pose des risques d'explosion. Remplacez seulement avec un Ray-O-Vac® no BR2335 ou un produit équivalent recommandé par le fabricant. Voir le guide d'utilisateur pour les instructions de sécurité. La pile utilisée dans cet appareil peut présenter un risque d'incendie ou de brûlure chimique si vous en faites mauvais usage. Ne pas recharger, démonter, chauffer à plus de 100°C ou incinérer. Éliminez les vieilles piles suivant les instructions du fabricant. Gardez la pile hors de la portée des enfants.</p>
For use in Pollution Degree 2 environment.	Pour l'utilisation dans un environnement de Degré de Pollution 2.
Ambient air temperature shall not exceed 40°C (104°F).	La température ambiante de l'air ne doit pas dépasser 40°C (104°F).
Terminal Ratings	Valeurs nominales des bornes
Wire Material Copper	Matériau de fil Cuivre
Tightening Torque Other Terminal Blocks: 0.8 Nm (7.0 in-lb)	Couple de Serrage Autres borniers : 0,8 Nm (7,0 livres-pouce)

Hazardous Locations Safety Marks

<p>⚠ WARNING – EXPLOSION HAZARD Open circuit before removing cover.</p>	<p>⚠ AVERTISSEMENT – DANGER D'EXPLOSION Ouvrir le circuit avant de déposer le couvercle.</p>
<p>⚠ WARNING – EXPLOSION HAZARD Substitution of components may impair suitability for Class I, Division 2.</p>	<p>⚠ AVERTISSEMENT – DANGER D'EXPLOSION La substitution de composants peut détériorer la conformité à Classe I, Division 2.</p>
Operating Temperature Range: -40°C to +85°C (-40°F to +185°F).	Plage de température de fonctionnement : -40°C à +85°C (-40°F à +185°F).
Hazardous Locations Operating Temperature Range: -20°C to +40°C (-4°F to +104°F).	Emplacements Plage de température de fonctionnement d'emplacements dangereux : -20°C à +40°C (-4°F à +104°F).

Other Safety Marks (Sheet 1 of 2)

<p>⚠ DANGER Disconnect or de-energize all external connections before opening this device. Contact with hazardous voltages and currents inside this device can cause electrical shock resulting in injury or death.</p>	<p>⚠ DANGER Débrancher tous les raccordements externes avant d'ouvrir cet appareil. Tout contact avec des tensions ou courants internes à l'appareil peut causer un choc électrique pouvant entraîner des blessures ou la mort.</p>
<p>⚠ DANGER Contact with instrument terminals can cause electrical shock that can result in injury or death.</p>	<p>⚠ DANGER Tout contact avec les bornes de l'appareil peut causer un choc électrique pouvant entraîner des blessures ou la mort.</p>

Other Safety Marks (Sheet 2 of 2)

<p>⚠ WARNING Use of this equipment in a manner other than specified in this manual can impair operator safety safeguards provided by this equipment.</p>	<p>⚠ AVERTISSEMENT L'utilisation de cet appareil suivant des procédures différentes de celles indiquées dans ce manuel peut désarmer les dispositifs de protection d'opérateur normalement actifs sur cet équipement.</p>
<p>⚠ WARNING Have only qualified personnel service this equipment. If you are not qualified to service this equipment, you can injure yourself or others, or cause equipment damage.</p>	<p>⚠ AVERTISSEMENT Seules des personnes qualifiées peuvent travailler sur cet appareil. Si vous n'êtes pas qualifiés pour ce travail, vous pourriez vous blesser avec d'autres personnes ou endommager l'équipement.</p>
<p>⚠ WARNING This device is shipped with default passwords. Default passwords should be changed to private passwords at installation. Failure to change each default password to a private password may allow unauthorized access. SEL shall not be responsible for any damage resulting from unauthorized access.</p>	<p>⚠ AVERTISSEMENT Cet appareil est expédié avec des mots de passe par défaut. A l'installation, les mots de passe par défaut devront être changés pour des mots de passe confidentiels. Dans le cas contraire, un accès non-autorisé à l'équipement peut être possible. SEL décline toute responsabilité pour tout dommage résultant de cet accès non-autorisé.</p>
<p>⚠ CAUTION Equipment components are sensitive to electrostatic discharge (ESD). Undetectable permanent damage can result if you do not use proper ESD procedures. Ground yourself, your work surface, and this equipment before removing any cover from this equipment. If your facility is not equipped to work with these components, contact SEL about returning this device and related SEL equipment for service.</p>	<p>⚠ ATTENTION Les composants de cet équipement sont sensibles aux décharges électrostatiques (DES). Des dommages permanents non-décelables peuvent résulter de l'absence de précautions contre les DES. Raccordez-vous correctement à la terre, ainsi que la surface de travail et l'appareil avant d'en retirer un panneau. Si vous n'êtes pas équipés pour travailler avec ce type de composants, contacter SEL afin de retourner l'appareil pour un service en usine.</p>
<p>⚠ CAUTION Use of controls or adjustments, or performance of procedures other than those specified herein, may result in hazardous radiation exposure.</p>	<p>⚠ ATTENTION L'utilisation de commandes ou de réglages, ou l'application de tests de fonctionnement différents de ceux décrits ci-après peuvent entraîner l'exposition à des radiations dangereuses.</p>
<p>⚠ CAUTION Changes or modifications not expressly approved by the party responsible for compliance could void the user's authority to operate the equipment.</p>	<p>⚠ ATTENTION Les changements ou modifications qui ne sont pas expressément approuvés par l'autorité responsable de se prononcer sur la conformité pourraient annuler le pouvoir de l'utilisateur à actionner l'équipement.</p>
<p>⚠ CAUTION Connect only 120 Vac nominal to the SEL-734B socket stab VOLTAGES connector.</p>	<p>⚠ ATTENTION Connecter seulement 120 Vca nominal au connecteur de prise VOLTAGES (Tensions) du SEL-734B</p>
<p>⚠ CAUTION Ground the SEL-734B Capacitor Bank Control cabinet chassis before making any other connections to the cabinet.</p>	<p>⚠ ATTENTION Mettre à la terre le châssis de l'armoire du Contrôle de batterie de condensateurs SEL-734B avant de faire toute autre connexion à l'armoire.</p>

General Information

Trademarks

All brand or product names appearing in this document are the trademark or registered trademark of their respective holders. No SEL trademarks may be used without written permission.

Trademarks appearing in this manual are shown in the following table.

SEL Trademarks	
ACCELERATOR QuickSet®	SELOGIC®

Technical Assistance

We appreciate your interest in SEL products and services. If you have questions or comments, please contact us at:

Schweitzer Engineering Laboratories, Inc.
2350 NE Hopkins Court
Pullman, WA 99163-5603 U.S.A.
Tel: +1.509.338.3838
Fax: +1.509.332.7990
Internet: selinc.com/support
Email: info@selinc.com

Section 1

Overview

Introduction

The SEL-734B Capacitor Bank Control, with low-energy analog (LEA) inputs, provides advanced capabilities for capacitor bank control and feeder monitoring. Design templates are custom settings interfaces, built for the Full-Size Enclosure and Compact Enclosure models, which configure the SEL-734B for capacitor bank control.

This Field Reference Guide describes procedures by which the user can perform the following actions.

- Install any type of SEL-734B enclosure model
- Establish initial communications
- Configure critical settings applicable to all design templates
- Commission, troubleshoot, and test the system

For model-specific operation and functions, please refer to the appropriate design template guide, located at selinc.com.

NOTE: The SEL-734B is also available as a loose device, not installed in an enclosure and not programmed for capacitor bank control.

SEL offers the SEL-734B device installed inside of an outdoor-rated enclosure and preconfigured for capacitor bank control. *Figure 1.1* shows the SEL-734B model options.



Figure 1.1 SEL-734B Model Options in Outdoor-Rated Enclosures

SEL-734B Front Panel

This section describes the general front-panel functionality of the SEL-734B. Refer to the associated Capacitor Bank Control Design Template Guide for information on the front-panel functionality when the device is factory-programmed for capacitor bank control.

The function of front-panel LEDs and pushbuttons are factory-programmed based on your enclosure model option. Blank labels shipped with the device can be used to indicate new functionality. *Figure 1.2* depicts the front panel of the SEL-734B with default labels installed as on the standalone device.



Figure 1.2 SEL-734B Front Panel

ENABLED LED

This LED shows the diagnostics status of the SEL-734B. An illuminated **ENABLED LED** indicates that the SEL-734B is operating properly. If the **ENABLED LED** turns off, the SEL-734B requires service.

Configurable LEDs and Pushbuttons

All front-panel LEDs except for the **ENABLED LED** are configurable. The SEL-734B has four control pushbuttons and one **TARGET RESET** button. Custom labels on the front panel and settings in the device define the functionality of the pushbuttons and LEDs. Refer to the appropriate design template guide for details on the functionality of the capacitor bank control program.

Test Front-Panel LEDs

Press the **TARGET RESET** button to illuminate all front-panel LEDs for test. This pushbutton is configurable and performs other functions for capacitor bank control. Please refer to the appropriate design template guide for details on the programmed functionality of the **TARGET RESET** pushbutton.

Menu Pushbuttons

The menu pushbuttons provide access to the front-panel menu and are not configurable. You can use the menu to perform the following tasks:

- View the status and diagnostics of the SEL-734B
- View metering data
- View and change device settings
- View event data

SEL-734B Rear Panel

Figure 1.3 shows a diagram of the rear-panel connections on a typical SEL-734B model.

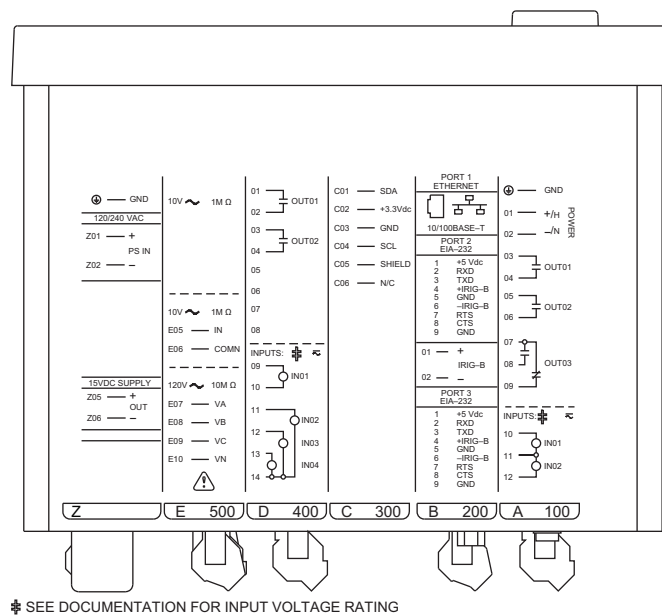

⚡ SEE DOCUMENTATION FOR INPUT VOLTAGE RATING

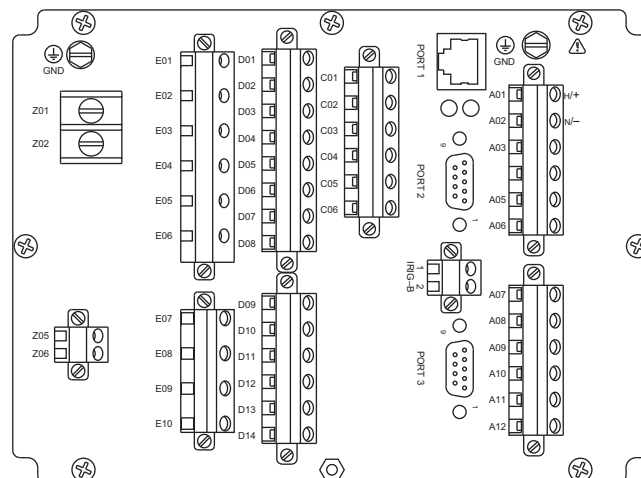

Figure 1.3 Top Label and Rear Panel

A label on the top of the SEL-734B defines the function of each rear-panel terminal or communications port.

The rear panels are divided into six slots: Slot A, B, C, D, E, and Z. Terminals are designated by the slot letter and the terminal number. For example, Slot D terminals are designated D01 through D14.

Power Supply Board

Slot A contains the circuit board to power the SEL-734B. The SEL-734B is available in three different power supply options:

- 125/250 Volts AC/DC - comes with a green Euro connector.
- 24/48 Volts DC - comes with an orange Euro connector.
- 12/24 Volts DC - comes with an orange Euro connector.

Figure 1.4 shows the orange connector on the 24/48 Vdc power supply.

Slot A also contains two Form A output contacts, one Form C output contact, and two digital inputs. In the Full-Size Enclosure option, the two Form A contacts operate the capacitor bank switch.

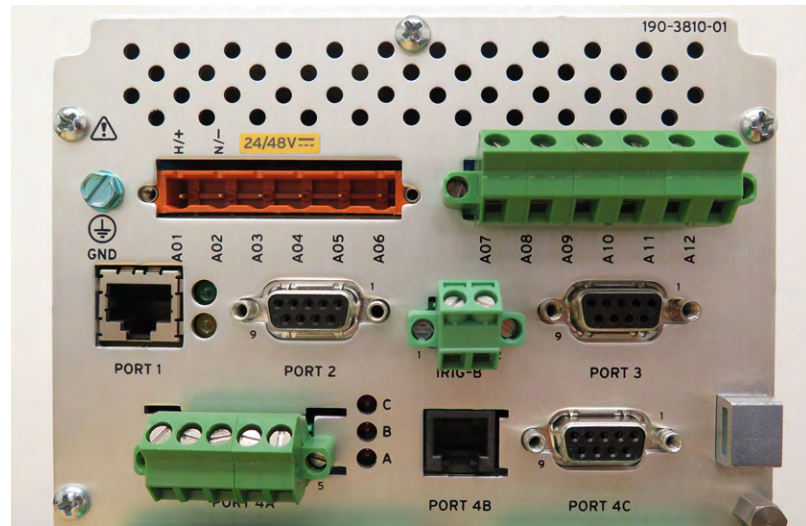

Figure 1.4 24/48 Vdc Power Supply

Main CPU Board

Slot B contains the main CPU board. This slot also contains two EIA-232 communications ports. The Ethernet port is also located on this board.

Temperature Sensor Input Board

The SEL standard temperature sensor provides ambient air temperature sensing capabilities to the SEL-734B. You can use this with the Time/Temperature QuickSet settings template to perform advanced temperature and time-based control.

Additionally, real-time temperature can be reported as an analog quantity in DNP3 communications within a distribution automation system.

The SEL-734B temperature is reported in Fahrenheit as analog quantity AI302. The settings template features two different time/temperature-based control programs that you can configure to enable automatically, allowing for seasonal variation control. SELOGIC control equations can use the temperature values for setting an alarm or supervising other control functions.

Input/Output Board

Slot D contains an input/output (I/O) board. The board contains the output contacts to operate the capacitor bank switches. All output contacts on this board operate the capacitor bank switches.

Note: There are two versions of the I/O board for the SEL-734B that can be used, depending on the application.

- ▶ For compact enclosures with ganged three-phase control, Slot D includes two hybrid digital outputs with 30 A current carry capability to open and close a ganged capacitor switch.
- ▶ For full-size enclosures with individual-phase switching, Slot D includes four standard contact outputs to switch to open and close single-phase capacitor switches. The remaining capacitor switch is opened and closed using contact outputs from Slot A.

Voltage and Current Measurement Board

Slot E contains the low-energy analog (LEA) input board. Three voltage sensors and three current sensors connect to this board. Optionally, the board can have a fourth neutral current channel.

Note: There are two versions of the LEA cards for the SEL-734B for use depending on the application.

NOTE: The compact SEL-734B measures voltage from the same PT that powers the device. The wiring connects the voltage and current measurement board with the power supply board. The full-size SEL-734B measures power from a 25 Vac LEA input, and the voltage measurement board and power supply board are independent. This means that a separate voltage sensor is required to measure voltage on a full-size SEL-734B.

- ▶ **4 LEA Current Sense Inputs and 3 LEA Voltage Sense Inputs (1 M Ω input impedance, 0.1–12.5 Vac and 10 M Ω input impedance, 0.4–25.0 Vac, respectively).** This card is used in Full-Size Enclosures in which sensing and control of the three phases are typically independent, and combination line post sensors are used (which provide both voltage and current signals for each phase).
- ▶ **4 LEA Current Sense Inputs and 3 Single-Phase Voltage Sense Inputs (1 M Ω input impedance, 0.1–12.5 Vac and 10 M Ω input impedance, 57–150 Vac, respectively).** This card is used in compact enclosures in which there is typically only one phase of sensing and the three capacitor switches are operated simultaneously. In these applications, a single current-only line post sensor is used, and the control power transformer voltage is used as the voltage sensing input.

Integrated 15 Vdc Power Supply Board

Slot Z optionally contains the integrated 15 Vdc power supply for accessories. This module provides a 15 Vdc source to power accessories in the cabinet.

Enclosure Hardware

The following section provides a description of the ancillary hardware included in the SEL-734B enclosure.

Front-Panel Voltage Jacks

The voltage test jacks labeled **LINE** and **NEUTRAL** are for use with a handheld voltage meter to measure the voltage provided to the cabinet. These jacks are not designed to be used as external power jacks.

Fuse Holders

The device is electrically protected by a 12 A fuse labeled **LINE** on the front panel. The fuse labeled **Neutral MOV** protects the neutral leg of the MOV surge arrester. This fuse will not disconnect the neutral from the cabinet; it only disconnects the neutral of the MOV to protect against damage in the unlikely event of an MOV failure.

Serial and Ethernet Patch Cables

Some socket-based and 7-pin compact enclosures have patch cables connected to the communications ports on the rear of the SEL-734B.

An Ethernet port is always accessible from the front of the enclosure via an Ethernet cable.

In socket-based enclosures, two serial patch cables connect to **PORT 2** and **PORT 3** of the SEL-734B. The patch cables are accessible from the front of the enclosure. The cables have a male DB-9 connector, and one female/female DB-9 gender changer is provided with the enclosure.

Front Door Label

Socket-based compact enclosures provide a schematic diagram on the inside of the enclosure door. The following information is also included on the label:

- Serial number
- Model option number

SEL-3061 Cellular Router

Socket-based compact enclosures and full-size enclosures are available with the SEL-3061 Cellular Router. When the enclosure is ordered with the cellular router, SEL installs two N-type surge arrestors on the bottom of the enclosure to allow connection of two antennas. The antennas and cables are sold separately.

SEL-2401 Satellite-Synchronized Clock

Compact Enclosure

Socket-based compact enclosures are available with the SEL-2401 Satellite-Synchronized Clock. Enclosures ordered with the SEL-2401 are equipped with a TNC-type surge protector wired to the bottom of the enclosure with a coaxial cable. The SEL-2401 IRIG-B output is connected to the SEL-734B IRIG-B input. An antenna kit is included in the box, which contains a low-profile GPS antenna, a mounting kit, and a coaxial cable.

Full-Size Enclosure

Full-size enclosures are available with the SEL-2401 pre-installed. Enclosures ordered with the SEL-2401 come with the SEL-2401 output connected to the IRIG-B input on the SEL-734B and a TNC-type surge arrester and connector installed on the bottom of the enclosure to allow for connection of a satellite antenna. An antenna kit is included in the box, which contains a low-profile GPS antenna, a mounting kit, and a coaxial cable.

Open Door Indications

All compact enclosure models have a door switch wired to a digital input on the SEL-734B. The digital input changes state when the door is opened and the indication is mapped to the DNP Binary Inputs for SCADA. Open door indicators are not available for the full-size enclosures

Section 2

Field Connections to the Enclosures

Overview

CAUTION

Ground the SEL-734B Capacitor Bank Control cabinet before making any other connections to the cabinet.

This section describes the field connections to the enclosure. A description of the control and sensor cables is also given. Detailed drawings of the various cables are provided in *Appendix D: Cable Drawings*.

Connections to Full-Size Enclosures

SEL offers two versions of the Full-Size Enclosure. The Combined Sensor Connector version contains one 14-pin sensor connector and one 19-pin control connector. The Individual Sensor Connector version contains three 4-pin sensor connectors, one 19-pin control connector, and one 4-pin power supply/neutral sensor connector.

Combined Sensor Connector Version

Figure 2.1 shows the bottom view of the Full-Size Enclosure model with the combined sensor connector. All three phase sensors and the neutral sensor connect to the 14-pin connector on the bottom of the enclosure. Optionally, you can connect a neutral current sensor to terminal blocks inside the enclosure and route the cabling through openings on the bottom of the enclosure. The 19-pin connector routes the control power to the switches from the enclosure.

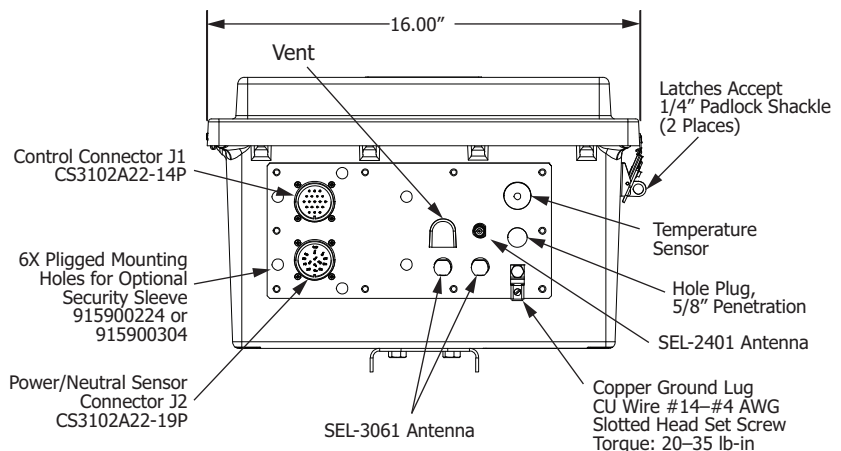

Figure 2.1 Bottom View of Enclosure With Combined Sensor Connector

19-Pin Control Connector J1

The control connector sends open and close signals to each capacitor bank switch, contains provisions to monitor the auxiliary (52a and 52b) contacts, and connects to the control power transformer. *Table 2.1* lists the functions of the connector's pins.

Table 2.1 Pinout of 19-Pin Control Connector J1 for Full-Size Enclosures With the Combined Sensor Connector

Pin Number	Description
A	120 Vac Control Power Transformer
B	Control Power Transformer Neutral
C	Open A-Phase
D	Close A-Phase
E	Reserved
F	Open B-Phase
G	Close B-Phase
H	Reserved
J	Open C-Phase
K	Close C-Phase
L	Reserved
M	A-Phase 52a Auxiliary Contact
N	A-Phase 52b Auxiliary Contact
P	B-Phase 52a Auxiliary Contact
R	B-Phase 52b Auxiliary Contact
S	C-Phase 52a Auxiliary Contact
T	C-Phase 52b Auxiliary Contact
U	Reserved
V	Reserved

Control Cables for Enclosures With the Combined Sensor Connector

Each of the following cables connect to the 19-pin control connector. Use *Table 2.2* to identify the control cable compatible with your installation.

Table 2.2 Control Cables for Full-Size Enclosures With the Combined Sensor Connector

SEL Cable	Cable Diagram	Notes
SEL-C543		<ul style="list-style-type: none"> ➤ Connects to three switches and the control power transformer ➤ Compatible with Joslyn VersaVac and Cooper oil switches ➤ 5-pin (18-11S) female connectors ➤ Military standard 3106 style ➤ Supports 52b monitoring ➤ Compatible with security sleeve 915900311 ➤ Installation example: <i>Figure C.1</i>
SEL-C544		<ul style="list-style-type: none"> ➤ Connects to three switches and the control power transformer ➤ Compatible with Joslyn VersaVac and Cooper oil switches ➤ 6-pin (18-12S) female connectors ➤ Military standard 3106 style ➤ Supports 52a and 52b monitoring ➤ Compatible with security sleeve 915900311 ➤ Installation example: <i>Figure C.1</i>
SEL-C547		<ul style="list-style-type: none"> ➤ Connects to three switches and the control power transformer ➤ 7-pin (16S-1S) female connectors ➤ Supports 52a and 52b monitoring ➤ Compatible with security sleeve 915900311 ➤ Installation example: <i>Figure C.1</i>
SEL-C556		<ul style="list-style-type: none"> ➤ Connects to an Eaton/Cooper junction box (CCR116K1) ➤ Controls three single-pole switches ➤ 19-pin (22-14S) female connector ➤ Supports 52a and 52b monitoring ➤ Compatible with security sleeve 9250011 ➤ Installation example: <i>Figure C.2</i>

14-Pin Combined Sensor Connector J2

The combined sensor connector routes the voltage and current measurements from each phase to the SEL-734B. Optionally, you can connect a neutral sensor to the connector. *Table 2.3* lists the function of the connector's pins.

Table 2.3 Pinout of 14-Pin Combined Sensor Connector J2 for Full-Size Enclosures (Sheet 1 of 2)

Pin Number	Description
A	Reserved
B	Reserved
C	Neutral Sensor, Positive Polarity
D	Neutral Sensor, Common
E	A-Phase Voltage Sensor
F	B-Phase Voltage Sensor
G	C-Phase Voltage Sensor
H	Voltage Sensors Common

Table 2.3 Pinout of 14-Pin Combined Sensor Connector J2 for Full-Size Enclosures (Sheet 2 of 2)

Pin Number	Description
J	A-Phase Current Sensor, Positive Polarity
K	Reserved
L	B-Phase Current Sensor, Positive Polarity
M	Current Sensors Common
N	C-Phase Current Sensor, Positive Polarity
P	Reserved

Sensor Cables for Enclosures With the Combined Sensor Connector

Each of the following cables connects to the 14-pin measurement connector. Use *Table 2.4* to identify the sensor cable that is compatible with your installation.

Table 2.4 Sensor Cables for Full-Size Enclosures With the Combined Sensor Connector

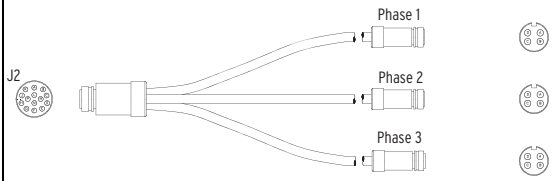
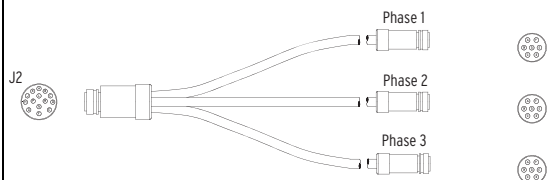
Cable	Cable Diagram	Notes
R-22748/XX,YY	Visit selinc.com/products/73x/734b-full-enclosure/	<ul style="list-style-type: none"> ➤ Connects to three Lindsey Manufacturing sensors and one Lindsey Neutral Current Sensor ➤ 4-Pin (14S-2P) male connectors ➤ Installation example: <i>Figure C.1</i>
SEL-C529		<ul style="list-style-type: none"> ➤ Connects to three Lindsey Manufacturing sensors ➤ Three 4-pin (14S-2P) male connectors ➤ Compatible with security sleeve 9250011 ➤ Installation example: <i>Figure C.2</i>
SEL-C536		<ul style="list-style-type: none"> ➤ Connects to three Piedmont LSCV-SEL sensors ➤ Three 7-pin (16S-1P) male connectors ➤ Compatible with security sleeve 9250011 ➤ Installation example: <i>Figure C.2</i>

Individual Sensor Connector Versions

Figure 2.2 shows the bottom view of the enclosure with individual sensor connectors. This version contains five connectors located on the bottom.

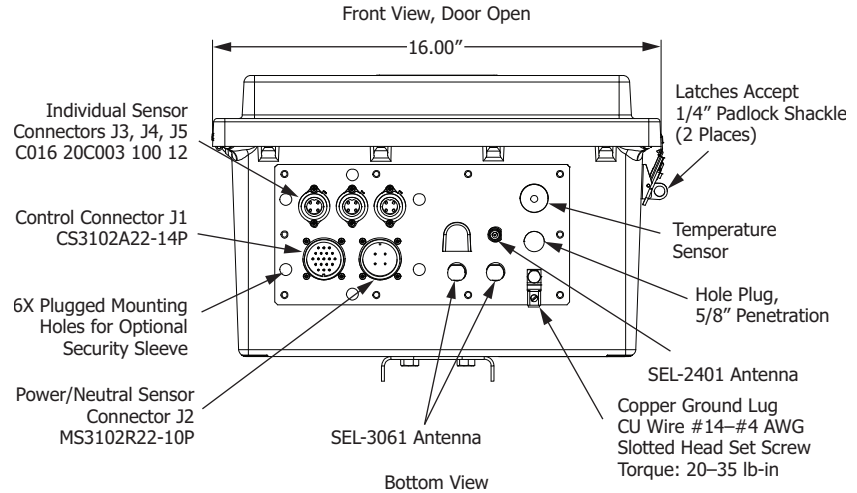

Figure 2.2 Bottom View of Enclosure With Individual Sensor Connectors

Control Connector J1

Connector **J1** sends open and close signals to each capacitor bank switch and includes provisions to monitor the auxiliary (52a and 52b) contacts. *Table 2.5* lists the functions of the connector's pins.

Table 2.5 Pinout of 19-Pin Control Connector J1 for Full-Size Enclosures With Individual Sensor Connectors

Pin Number	Description
A	Not Connected
B	System Neutral
C	Open A-Phase
D	Close A-Phase
E	Reserved
F	Open B-Phase
G	Close B-Phase
H	Reserved
J	Open C-Phase
K	Close C-Phase
L	Reserved
M	A-Phase 52a Auxiliary Contact
N	A-Phase 52b Auxiliary Contact
P	B-Phase 52a Auxiliary Contact
R	B-Phase 52b Auxiliary Contact
S	C-Phase 52a Auxiliary Contact
T	C-Phase 52b Auxiliary Contact
U	System Neutral
V	System Neutral

Control Cables for Enclosures With Individual Sensor Connectors

Each of the following cables connect to the 19-pin control connector. Use *Table 2.6* to identify the control cable that is compatible with your installation.

Table 2.6 Control Cables for Full-Size Enclosures With Individual Sensor Connectors

SEL Cable	Cable Diagram	Notes
SEL-C537		<ul style="list-style-type: none"> ▶ Connects to three switches ▶ 5-pin female connector ▶ Military standard 3106 Style ▶ Insert arrangement 18-11S ▶ Installation example: <i>Figure C.3</i> ▶ Control power transformer connected separately
SEL-C538		<ul style="list-style-type: none"> ▶ Connects to three switches ▶ 6-pin female connector ▶ Military standard 3106 Style ▶ Insert arrangement 18-12S ▶ Installation example: <i>Figure C.3</i> ▶ Control power transformer connected separately

4-Pin Sensor Connectors J3, J4, and J5

Connector **J3**, **J4**, and **J5** each connect to a single combination (measures voltage and current) sensor. Install the SEL-C530S shorting plug in unused connectors to minimize noise measurement. *Table 2.7* lists the functions of each pin.

Table 2.7 Pinout of 4-Pin Individual Sensor Connectors J3, J4, and J5

Pin Number	Description
1	A-, B-, or C-Phase Current Sensor
2	Current Sensor Common
3	A-, B-, or C-Phase Voltage Sensor
4	Voltage Sensor Common

Sensor Cables for Enclosures With Individual Sensor Connectors

The following sensor cables connect to an individual phase sensor connector. Please use *Table 2.8* to identify the cable that is compatible with your installation.

Table 2.8 Sensor Cables for Full-Size Enclosures With Individual Sensor Connectors

Cable	Cable Diagram	Notes
SEL-C530		<ul style="list-style-type: none"> Connects to one Lindsey Manufacturing sensor 4-pin male connector, Ecomate C016 20H003 100 12 Alternative to the Lindsey 9-587/XX/9-582 cable Installation example: <i>Figure C.4</i> Compatible with security sleeves 915900304 and 915900224
Lindsey 9-587/XX/9-582	<p>LMC P/N R-22485 1" Shrink Tubing 3:1 2 PLCS (Length in Feet) XX 3"</p> <p>Amphenol Connector (Male) P/N C016 20H003 100 12 P/N 9-587</p> <p>Amphenol Connector (Female) P/N C016 20D003 100 12 P/N 9-582</p>	<ul style="list-style-type: none"> Connects to one Lindsey Manufacturing sensor 4-pin male connector, Ecomate C016 20H003 100 12 Alternative to the SEL-C530 cable Installation example: <i>Figure C.4</i>
SEL-C530S	Contact your SEL representative for the cable diagram	<ul style="list-style-type: none"> Sensor connector shorting plug Install into unused sensor connectors to prevent noise measurement Installation example: <i>Figure C.5</i> Compatible with security sleeves 915900304 and 915900224

4-Pin Power Supply/Neutral Sensor Connector J2

Connector **J2** connects to the 120 Vac control power transformer and a neutral current sensor. *Table 2.9* lists the functions of the connector's pins.

Table 2.9 Pinout of 4-Pin Power Supply/Neutral Connector J2 for Full-Size Enclosures With Individual Sensor Connectors

Pin Number	Description
A	120 Vac Control Power Transformer
B	Control Power Transformer Neutral
C	Neutral Sensor, Positive Polarity
D	Neutral Sensor, Common

Table 2.10 Power Supply/Neutral Sensor Control Cables for Full-Size Enclosures With Individual Sensor Connectors

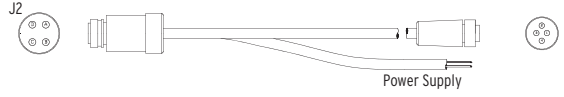
Cable	Cable Diagram	Notes
SEL-C532		<ul style="list-style-type: none"> Connects to the control power transformer and a neutral sensor Wire pigtails for neutral sensor and control power transformer Installation example: <i>Figure C.3</i> Compatible with security sleeves 915900304 and 915900224
SEL-C539		<ul style="list-style-type: none"> Connects to the cable of one Lindsey Manufacturing R-2298155 neutral sensor and the control power transformer 4-pin male connector Ecomate® C016 20H003 100 12, mates with Lindsey Sensor R-22981SS Installation example: <i>Figure C.4</i> Compatible with security sleeve 915900304

Connections to Compact Enclosures

CAUTION

Ground the SEL-734B Capacitor Bank Control cabinet before making any other connections to the cabinet.

This section describes the field connections for Compact Enclosure versions.

Socket-Based Versions

Figure 2.3 shows the rear of the socket-based enclosures, and *Table 2.11* shows the pinout of the socket stabs. SEL does not offer cables to install the socket-based enclosures. The socket-base should be wired to the field devices in accordance with *Table 2.11*.

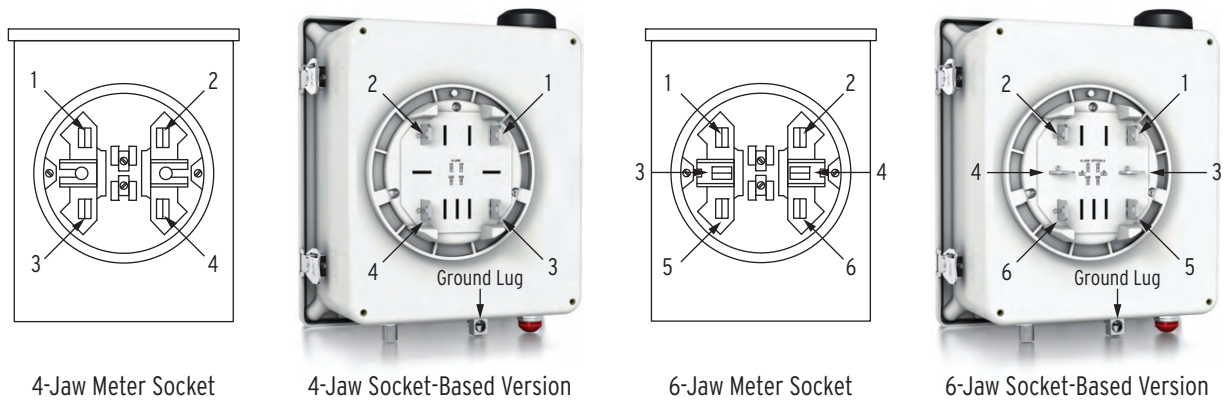

Figure 2.3 4- and 6-Jaw Socket Stabs

Table 2.11 Socket Stab Configurations^a

Enclosure Socket Option	Socket Stab Number and Function					
	1	2	3	4	5	6
4-Jaw	+CPT	-CPT	OPEN	CLOSE	—	—
6-Jaw Option A	+CPT	-CPT	•IN	•IA	OPEN	CLOSE
6-Jaw Option B	IA	-CPT	+CPT	OPEN	•IA	CLOSE

^a Where:
 +CPT: 120 Vac Control Power Transformer, Positive Polarity
 -CPT: 120 Vac Control Power Transformer, Neutral
 OPEN: Open Operating Signal Output Contact
 CLOSE: Close Operating Signal Output Contact
 •IA: Phase Current Sensor Input, Positive Polarity
 IA: Phase Current Sensor, Common
 •IN: Neutral Current Sensor Input, Positive Polarity
NOTE: The ground lug is isolated from the control power transformer neutral.

7-Pin Versions

The Connectorized version of the Compact Enclosure connects to equipment in the field through one 7-pin connector located on the bottom of the enclosure.

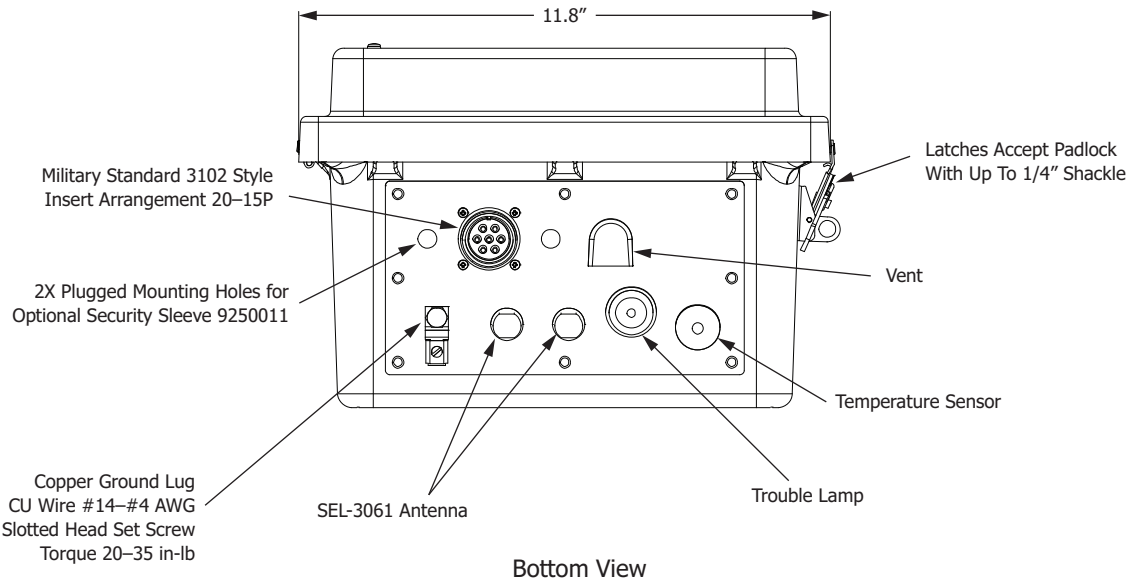

Figure 2.4 Bottom View of Connectorized Compact Enclosure

The terminal block version of the compact enclosure allows you to make your own connections to the device and eliminates the need for a Connectorized cable at the enclosure. This is useful for retrofit applications where the cabling is already present.

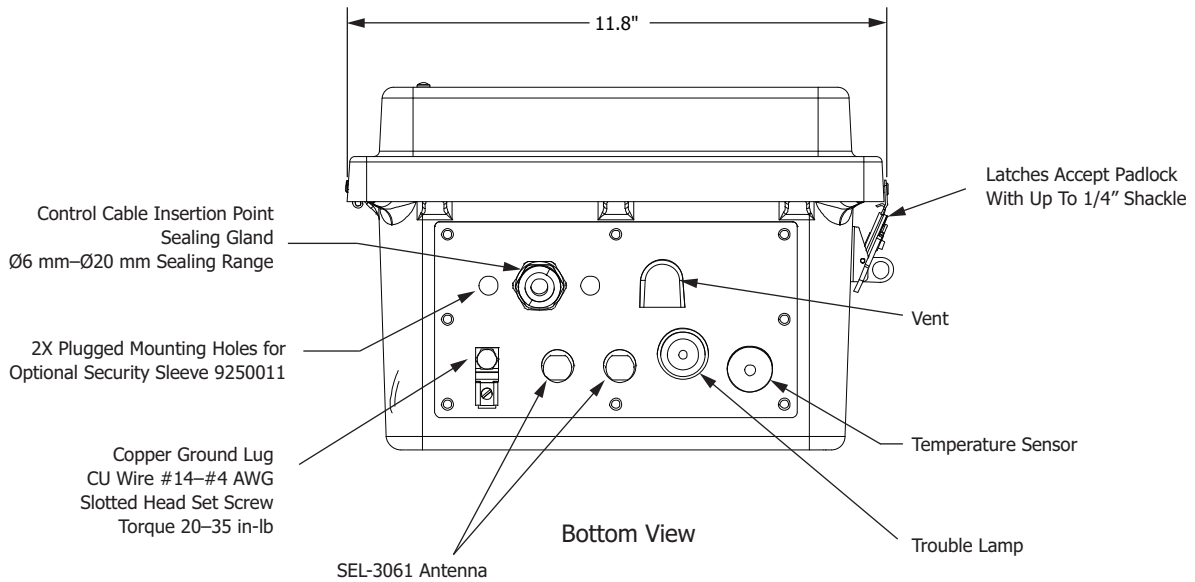

Figure 2.5 Bottom View of Terminal Block Enclosure

Table 2.12 Pinout of Control, Power, and Sensor Cable J1 for 7-Pin Connectorized Enclosure

Pin Number	Description
A	120 Vac Control Power Transformer, Positive Polarity
B	Open Operating Signal Output Contact
C	Close Operating Signal Output Contact
D	Neutral Current Sensor, Common
E	Neutral Current Sensor Input, Positive Polarity
F	Phase Current Sensor Input, Positive Polarity
G	120 Vac Control Power Transformer, Neutral

Table 2.13 shows the cable that is compatible with the Compact 7-Pin Enclosure.

Table 2.13 Control and Sensor Cable for the 7-Pin Connectorized Enclosure

Cable	Cable Diagram	Notes
SEL-C548		<ul style="list-style-type: none"> ➤ Bulkhead junction box connection with wire pigtails ➤ Connects to one phase-current sensor, one neutral sensor, the CPT, and the OPEN/CLOSE circuits of a three-pole switch ➤ Compatible with security sleeve 9250011 ➤ Installation example: <i>Figure C.6</i>

Accessories for Compact Enclosures

See *Appendix F: Accessories* for information on available accessories for the SEL-734B Compact Enclosures.

Section 3

Installing the Enclosure

Overview

The following procedures describe the steps to install the SEL-734B Capacitor Bank Control enclosures. Parts of the procedure vary with different enclosure models. Please refer to the applicable section for your enclosure model.

Grounding the Enclosure

CAUTION

Ground the SEL-734B Capacitor Bank Control cabinet chassis before making any other connections to the cabinet.

Always follow local utility grounding practices.

SEL recommends that the control power transformer serving the SEL-734B be on the same pole as the SEL-734B, as shown in *Figure 3.1*. All connections to the SEL-734B (e.g., ac supply from power transformer) must be routed in close proximity to, and parallel with, the ground conductor path for adequate surge protection. The connections and the ground path should be approximately equal in length. Primary lightning arrestors should be installed at the capacitor and at the control power transformer. All of these measures help reduce the possibility of equipment damage because of high voltages from surges.

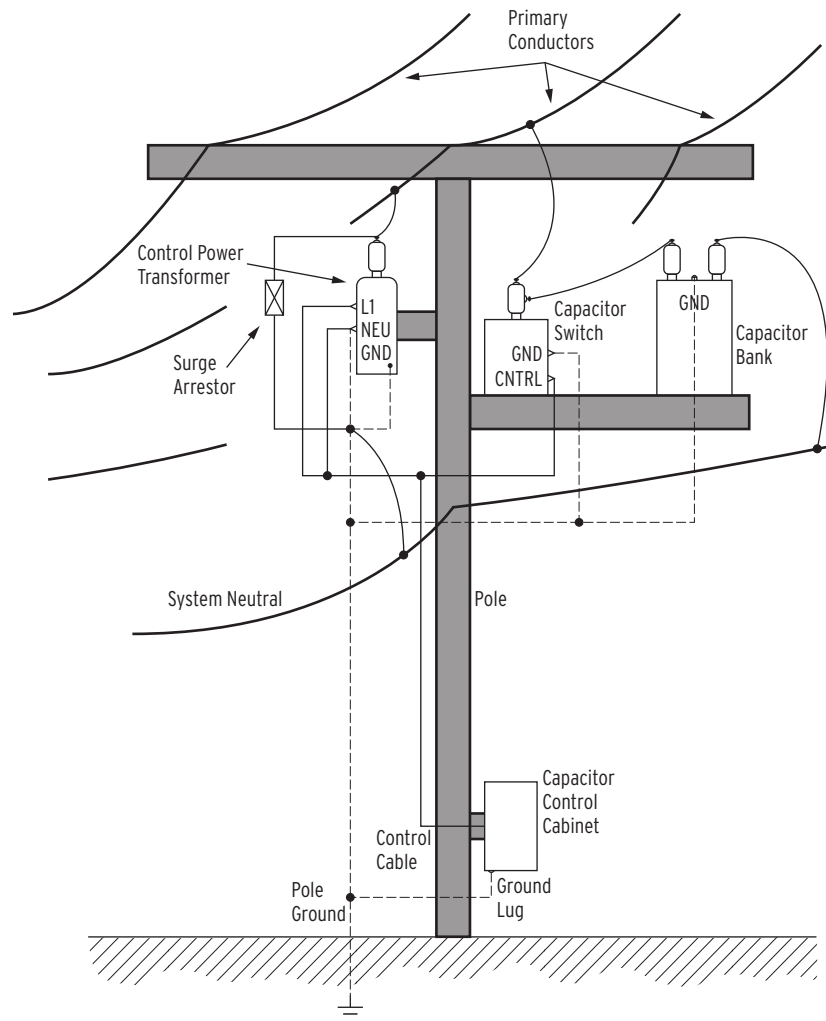

NOTE: In some full-sized enclosures and some older compact connectorized enclosures, the ground lug is bonded to system neutral. Confirm that your cabinet provides the correct ground-to-neutral connection, or separation, as required by your systems design.

Figure 3.1 SEL-734B Required System Grounding

In cabinets with a ground lug, the ground lug is bonded to the chassis ground of the SEL-734B and all metal parts in the cabinet. The ground lug is not bonded to system neutral (see note). It is vital that the cabinet ground be connected to the local ground conductor through use of local utility practices.

Pole-Mounting the Full-Size and Compact 7-Pin Enclosures

The Full-Size Enclosure may be ordered with a factory-installed pole-mounting bracket. The pole-mounting bracket for the Compact 7-Pin Enclosure is available as an accessory. *Figure 3.2* and *Figure 3.3* show the front view of the enclosure with the optional pole-mounting bracket attached.

Required equipment:

- (2x) 5/8" or 3/4" lag bolts
- 15/16" or 1-1/8" wrench
- Drill

Pole-Mounting the Full-Size and Compact 7-Pin Enclosures

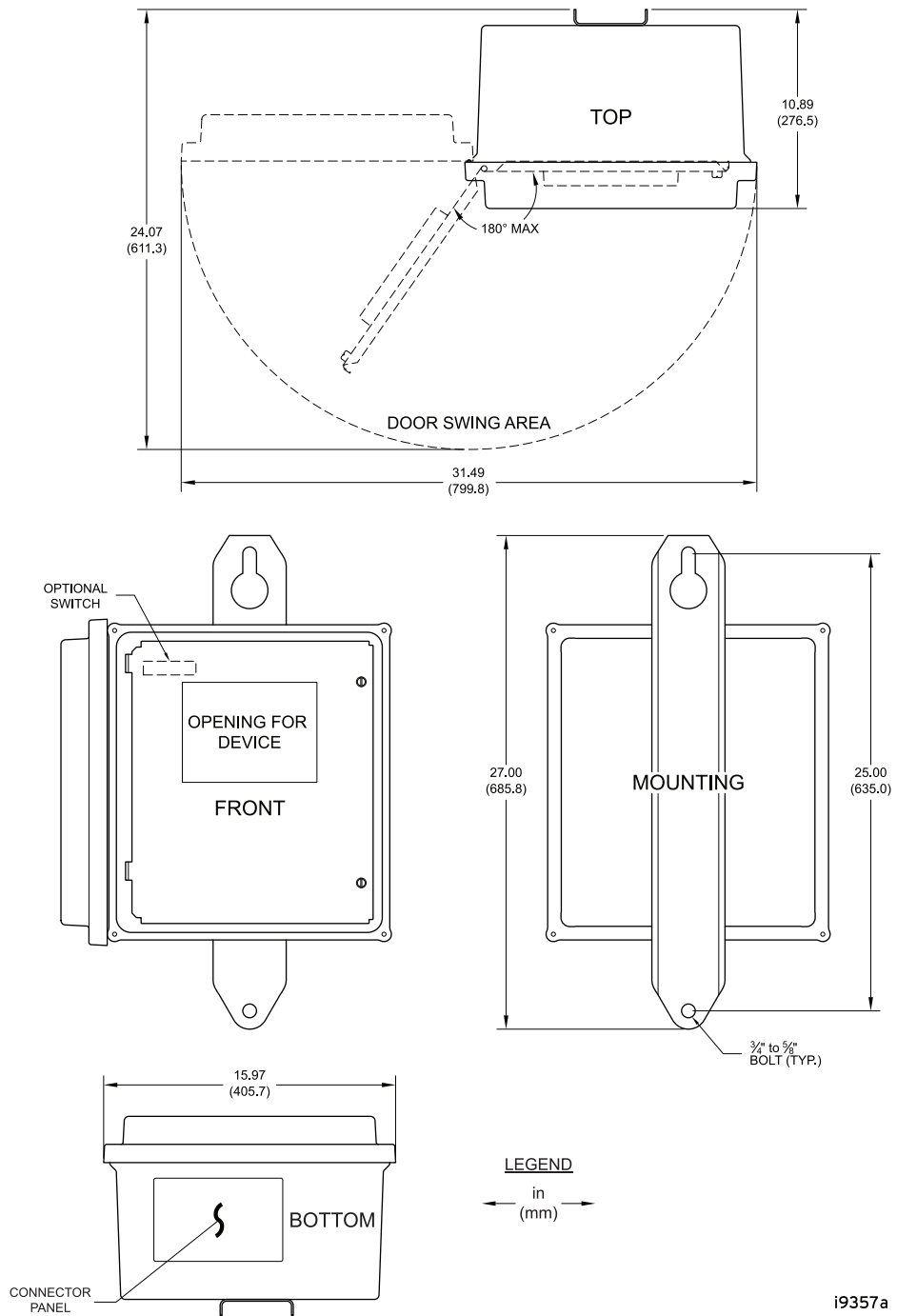

Figure 3.2 Full-Size Enclosure Mounting Dimensions

3.4 | Installing the Enclosure Connecting Full-Size Enclosures to a Control Power Transformer and Switches

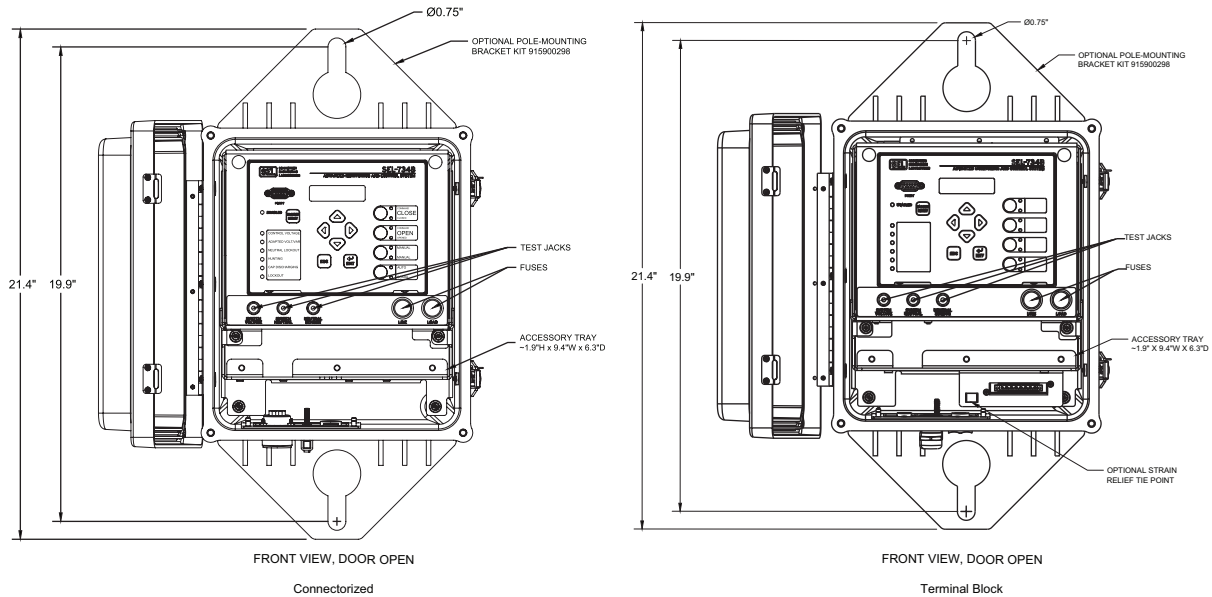

Figure 3.3 Compact 7-Pin Enclosure Mounting Dimensions

- Step 1. Use the dimensions given in *Figure 3.2* or *Figure 3.3* and drill two pilot holes for the lag bolts.
- Step 2. Install one lag bolt for the top mounting bracket.
- Step 3. Hang the enclosure from the lag bolt.
- Step 4. Install the other lag bolt into the bottom mounting bracket.
- Step 5. Tighten both lag bolts.

Connecting Full-Size Enclosures to a Control Power Transformer and Switches

SEL offers control cables that connect directly to the capacitor bank switches and to the control power transformer (CPT). Please refer to *Section 2: Field Connections to the Enclosures* to determine the correct cable for your installation.

The installation steps for the different enclosure styles vary slightly. Please complete the appropriate steps for your enclosure style.

Full-Size Enclosure With the Combined Sensor Connector

Perform the following steps to connect the SEL-734B with the combined sensor connector to the capacitor bank switches and the CPT.

- Step 1. Connect the enclosure to a local ground conductor.
- Step 2. Remove or open the fuses inside of the enclosure.
- Step 3. Use the appropriate control cable and connect the enclosure to the CPT and three capacitor bank switches.
- Step 4. Install the fuses removed in *Step 2*.
- Step 5. Ensure that the SEL-734B **ENABLED** LED illuminates.

Full-Size Enclosure With Individual Sensor Connectors

Perform the following steps to connect the SEL-734B with individual sensor connectors to the control power transformer and the capacitor bank switches.

- Step 1. Connect the enclosure to a local ground connector.
- Step 2. Remove or open the fuses inside of the enclosure.
- Step 3. Connect the enclosure to the CPT by connecting the SEL-C532, SEL-C539, or a functionally equivalent cable from the **POWER SUPPLY/NEUTRAL SENSOR** connector to the control power transformer connection.
- Step 4. Connect the enclosure to the capacitor bank switches by connecting the SEL-C537, SEL-C538, or functionality equivalent cable from the **CONTROL** connector to three capacitor bank switches.
- Step 5. Install the fuses removed in *Step 2*.
- Step 6. Ensure that the SEL-734B **ENABLED** LED illuminates.

Connecting Full-Size Enclosures to the Sensors

The installation of enclosures with the combined measurement connector differs from enclosures with individual measurement connectors. Use the appropriate cable, as described in *Section 2: Field Connections to the Enclosures*, to connect the enclosure to the sensors.

Mounting Socket-Based Enclosures

Use a locking ring to mount and hold the enclosure to the meter socket base. *Figure 3.4* shows a sample locking ring, which is orderable as kit 915900302.



Figure 3.4 Meter Locking Ring for Socket-Based Enclosure

Connecting Socket-Based Enclosures to a Control Power Transformer and Switches

SEL does not provide cabling or installation equipment other than the locking ring for the socket-based enclosure models. Ensure that the meter socket is properly wired to the capacitor bank switches and sensors and that the enclosure is connected to the local ground conductor.

Section 4

Configuring the SEL-734B

Overview

Refer to this section once the SEL-734B Capacitor Bank Control is turned on and connected to the switches and sensors.

This section details the procedure to perform the following actions:

- Check the status of the SEL-734B
- Establish communication with ACSELERATOR QuickSet SEL-5030 Software
- Check device status through the front-panel menu

Initial Communications Configuration

There are three ways to communicate with the SEL-734B:

- Using the front-panel menus and pushbuttons
- Using QuickSet
- Using a command line interface on a PC terminal emulation window

Record the Part Number and Serial Number of the Device

The part number and serial number are located on the side label of the SEL-734B and also inside the enclosure door.

Establish SEL Communication Between PC and the SEL-734B

- Step 1. Install QuickSet and the SEL-734 Settings Driver.
- Step 2. Connect an SEL-C234, SEL-C287, SEL-C662, or an equivalent serial cable to Port F or Port 2 and to the PC (Port 3 is reserved for Distributed Network Protocol [DNP3] communications).
- Step 3. Run QuickSet.
- Step 4. To access the communications parameters in QuickSet, select **Communications > Parameters**.

Step 5. Set communication parameters appropriately. *Figure 4.1* shows the default serial port parameters for Port F and Port 2 of the SEL-734B.

Step 6. Select **OK**.

The communications status is shown in the bottom left-hand corner of QuickSet.

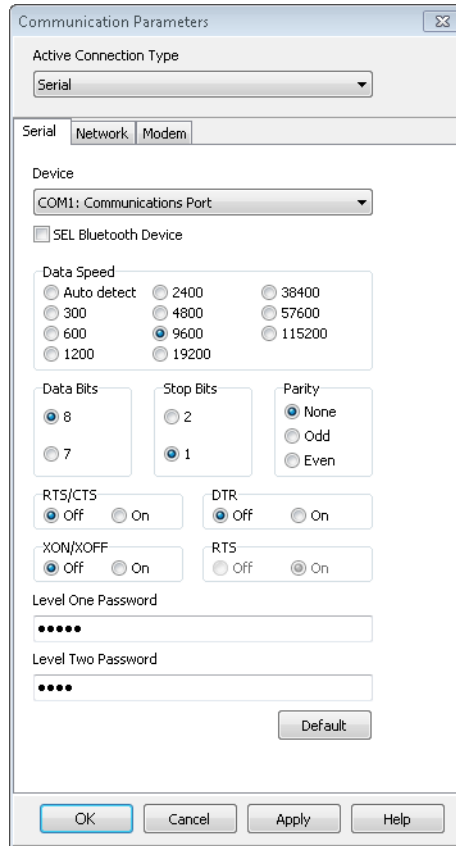

Figure 4.1 Default Serial Communication Parameters

Security

The SEL-734B supports four access levels to prevent unauthorized access. *Table 4.1* describes the default passwords and the capabilities of each access level. The user must enter Access Level 1 before entering Access Level E or Access Level 2.

Table 4.1 Default Passwords and Access Levels

Access Level	Terminal Prompt	Default Password	Capability
0AC	=	N/A	Entry access level
ACC	=>	OTTER	View configuration settings and meter data
EAC	E=>	BLONDEL	Reset demands and perform all Access Level 1 commands
2AC	=>>	TAIL	Change configuration settings, reset all data, and perform all commands

After the SEL-734B is turned on, the status of the device should be checked. You can check the status of the SEL-734B with the QuickSet HMI directly from the front-panel menu or by using a terminal program. Please refer to the appropriate section for instructions to check the status of the SEL-734B.

Check the Status of the Controller Using QuickSet

Complete the following steps to check the status of the device by using the QuickSet HMI. The following information is available: meter and firmware identifiers, serial number, diagnostic messages, date, and the time.

- Step 1. Establish communication to the SEL-734B.
- Step 2. Select the Human Machine Interface (HMI) icon () on the header ribbon. QuickSet will open the HMI window.
- Step 3. Navigate to the **Status** page, from the list on the left of the screen. The **Status** window will open.
- Step 4. Verify that the meter is enabled and note the firmware identifier (FID) and the serial number (S/N).

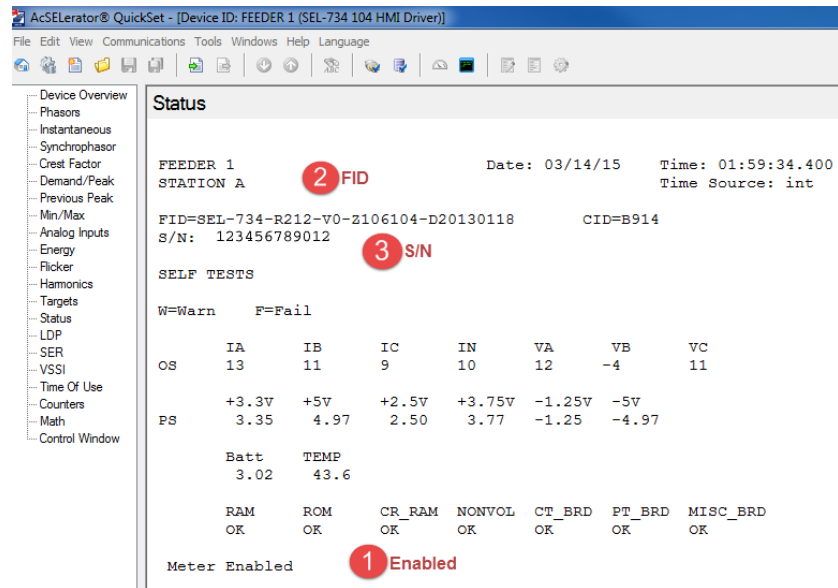

Figure 4.2 QuickSet HMI Status Window Example

- Step 5. Navigate to the **Capacitor Bank Control Overview** page from the list on the left of the screen. The **Capacitor Bank Overview** will open.
- Step 6. The Capacitor Bank Overview shows the controller status in the bottom of the page.

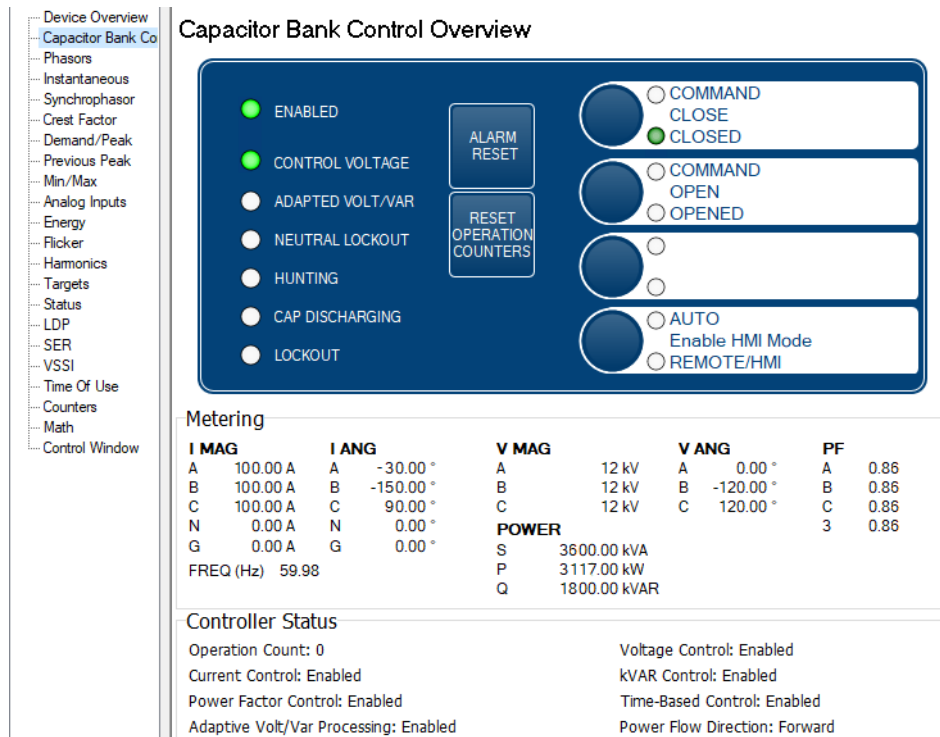

Figure 4.3 QuickSet HMI Capacitor Bank Control Overview

Check the Status of the Controller Using the Front-Panel Menu

Complete the following steps to check the status of the device by using the menu pushbuttons on the front of the SEL-734B.

- Step 1. Press the ENT button on the front panel.
- Step 2. Use the up/down arrow keys to select the Status option and press ENT.
- Step 3. Verify that the meter status displays Meter Enabled and note the firmware identifier FID and the serial number.

Check the Status of the Controller Using a Terminal Program

You can use an ASCII terminal program to check the status of the SEL-734B. The following steps detail this procedure using the QuickSet terminal program, but you can use other terminal programs.

- Step 1. Establish communication to the SEL-734B.
- Step 2. Select the QuickSet Terminal icon () on the header ribbon or open a terminal program and establish SEL ASCII communication to the device.
- Step 3. Enter Access Level 1.
 - a. Enter the ACC command.
 - b. When prompted, enter the Access Level 1 password.
 - c. Enter the STA command.
- Step 4. Verify that the meter is enabled.

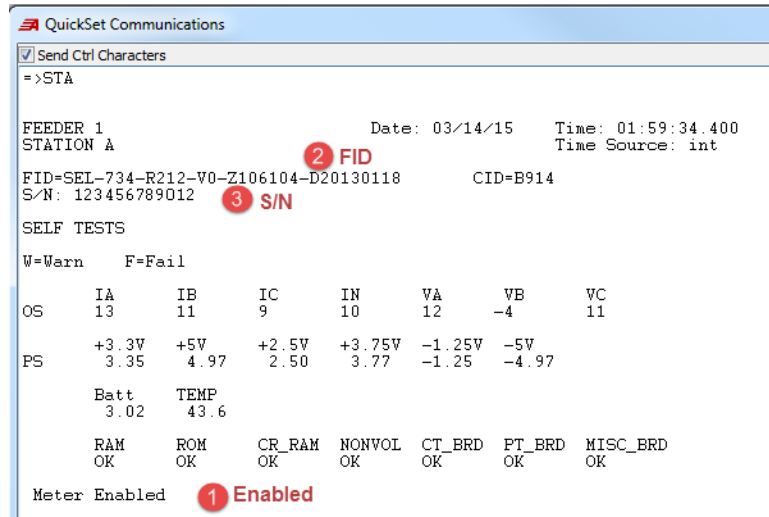

Figure 4.4 QuickSet Terminal Status Example

Change Passwords

To prevent unauthorized access, set strong passwords, as described in the following steps.

Using QuickSet

- Step 1. Open the QuickSet HMI.
- Step 2. Navigate to the **Control** window.
- Step 3. In the **Passwords** field, select the **Level** drop-down box and select the password level that you want to change.
- Step 4. Type the new password in the **New Password** and **Confirm Password** text boxes.
- Step 5. Select **Set** next to the **Confirm Password** text box.

QuickSet will show a message confirming that the password was reset.

Using the Front-Panel Menu

- Step 1. Press **ENT**.
- Step 2. Select the **Set/Show** menu and press **ENT**.
- Step 3. Select the **Set Password** menu and press **ENT**.
- Step 4. Select **EAC** to set the Access Level E password. Select **2AC** to set the Access Level 2 password. Press **ENT**. The SEL-734B will prompt you for the present Access Level 2 password.
- Step 5. Use the arrow buttons to navigate the text entry screen and enter the present Access Level 2 password. The SEL-734B will now prompt you for the new password.
- Step 6. Use the arrow buttons to navigate the text entry screen and enter the new password.

Using a Terminal Program

NOTE: To view the present password, enter the command without the password parameter.

- Step 1. Establish communication to the SEL-734B.
- Step 2. Select the QuickSet Terminal icon () on the header ribbon or open a terminal program and establish SEL ASCII communication to the device.
- Step 3. Enter Access Level 2.
 - a. Enter the **ACC** command.
 - b. When prompted, enter the Access Level 1 password.
 - c. Enter the **2AC** command.
 - d. When prompted, enter the Access Level 2 password.
- Step 4. Enter the following command syntax: **PAS *n password***, where *n* is the password level to change (1, E, 2) and *password* is the new password.
- Step 5. The SEL-734B responds with `Set` when the password has been changed.

Section 5

Working With the SEL-734B

Design Template Settings

Overview

An SEL-734B Capacitor Bank Control ordered in an enclosure comes with a pre-installed design template. Templates, designed for capacitor bank control, are also available on the SEL website.

Enclosure Model Features

The design templates are specific to each model option available for the SEL-734B. *Table 5.1* provides a complete reference about the available options.

Table 5.1 Control Features of Enclosure Models (Sheet 1 of 2)

Available Control Strategies	Enclosure/Field Interface				
	Full Size	Compact			
		4-Jaw	6-Jaw Option A	6-Jaw Option B	7-Pin (Connectorized and Terminal Block)
Ganged Phase Control	x	x	x	x	x
Individual Phase Control	x				
Voltage Control	x	x	x	x	x
kVAR Control	x		x	x	x
Power Factor Control			x	x	x
Current Control			x	x	x
Time/Temp-Based Control	x	x	x	x	x
Bidirectional kVAR Control ^a			x		x
Bidirectional Voltage Control ^a			x		x
Available Features					
Adaptive Voltage and kVAR Processing			x	x	x
Neutral Unbalance Alarm and Lockout	x		x		x
Switch Monitoring	x				
Capacitor Fault Detection	x		x		x
Integrated 15 Vdc Power Supply	x	x	x	x	x

Table 5.1 Control Features of Enclosure Models (Sheet 2 of 2)

Available Control Strategies	Enclosure/Field Interface				
	Full Size	Compact			
		4-Jaw	6-Jaw Option A	6-Jaw Option B	7-Pin (Connectorized and Terminal Block)
Harmonic Lockout		x	x	x	x
Overvoltage Lockout	x	x	x	x	x
Phase Overcurrent Fault Detection	x				
Hunting Lockout	x	x	x	x	x
Hunting Delay (Short-Term Hunting Problems)		x	x	x	x
Emergency Voltage Control	x	x	x	x	x
Separate Open and Close Delay Timers	x	x	x	x	x
Time-Based Control Voltage Offset		x	x	x	x

^a Power Factor Control, Current Control, and Time-Base Control are not available when using bidirectional capacitor bank controls.

Read Settings From the SEL-734B

The SEL-734B enclosure models are shipped with the design template loaded. Read the settings from the SEL-734B prior to changing the settings by performing the following steps:

- Step 1. Establish communications with the SEL-734B.
- Step 2. Select **File > Read** to read meter configuration settings.
ACSELERATOR QuickSet SEL-5030 Software prompts you to select the settings groups and classes to read, as shown in *Figure 5.1*.
- Step 3. Check the box titled **Read Designer Template from Device**. QuickSet automatically checks all of the settings groups and classes.
- Step 4. Select **OK**.

QuickSet will read the design template from the SEL-734B, then open the settings file in the design template viewport.

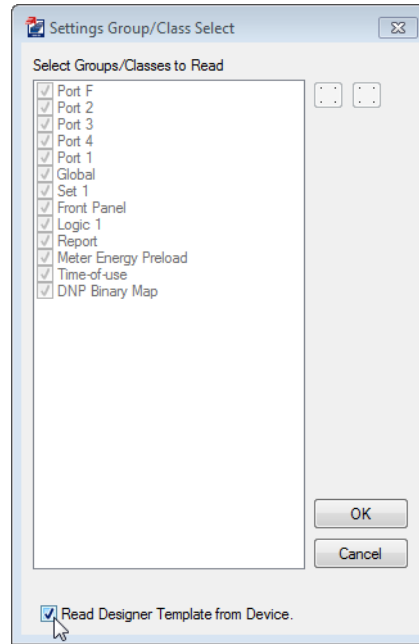

Figure 5.1 QuickSet Prompt to Read Settings Groups

Save Configuration Settings to the PC Hard Drive

- Step 1. Select **File > Save As** to save the active settings to an rdb database.
- Step 2. Select or create a new database.
- Step 3. Name the settings file.
- Step 4. Select **OK** to save the settings to the database selected.

Settings Window

Unlicensed versions of QuickSet provide two different viewing styles of the settings: the design template view and the settings editor view. In most cases, you will need to activate the design template view.

Design Template View

The Design Template view shows only the settings associated with the design template and hides all other device settings that are not related to capacitor bank control or communication.

Use the icons in the toolbar ribbon shown in *Figure 5.2* to switch between the Design Template Settings Editor and the general metering QuickSet Settings window.

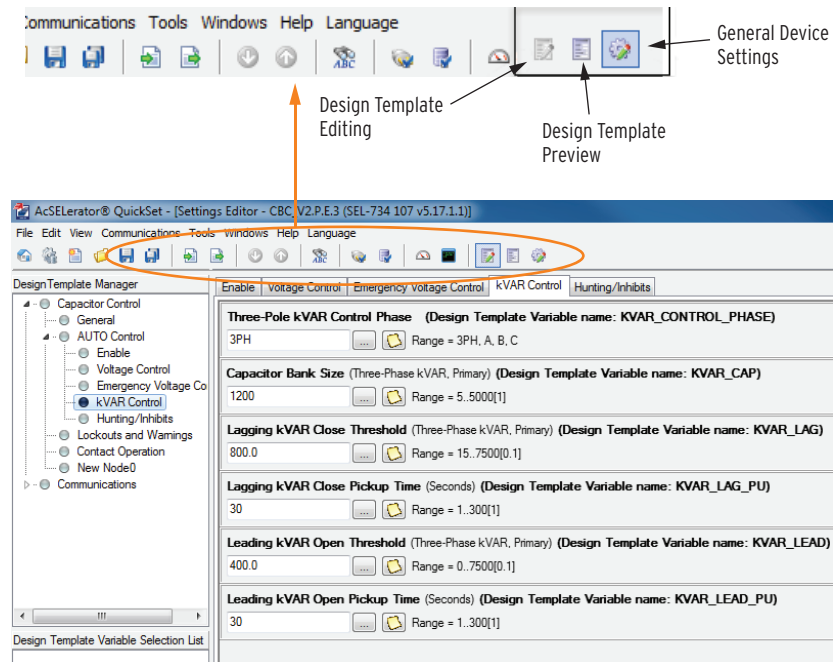

Figure 5.2 Design Template View

Settings Editor View

The Settings Editor view shows all device settings. To view settings in the Settings Editor view, select **View > Settings Editor**.

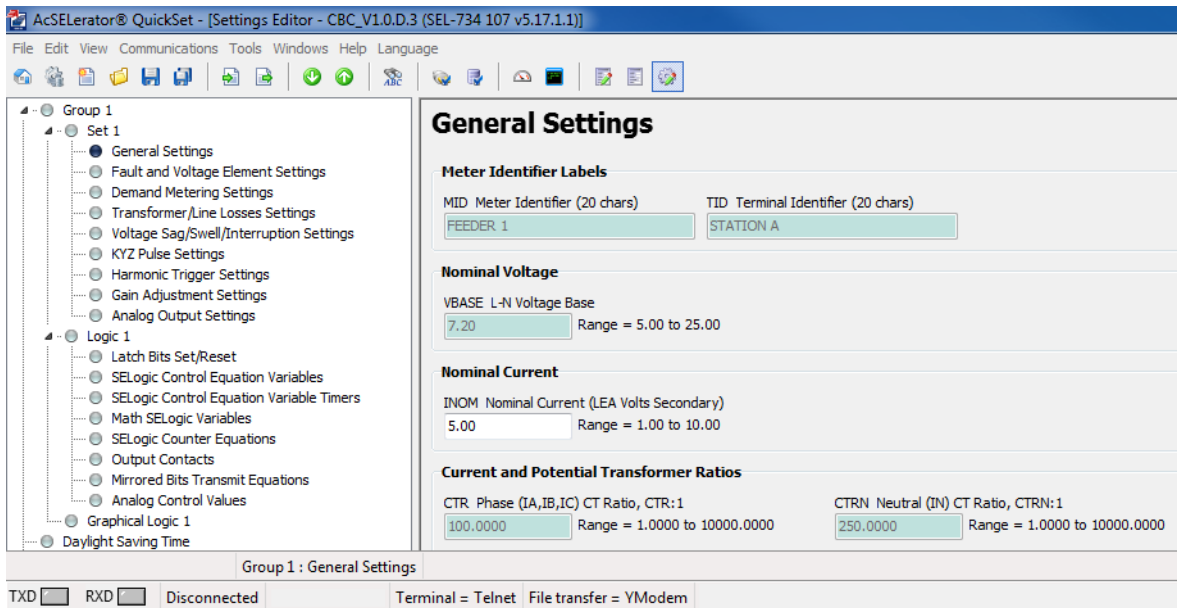

Figure 5.3 Settings Editor View of a Design Template

The shaded data fields are associated with the capacitor bank design template and you cannot change these settings. To make any changes from the Settings Editor view, please contact your local SEL representative.

To hide settings that you cannot configure from within the Settings Editor view, select **View > Settings Editor: [Name of Design Template] > Hide Disabled Settings**.

A checkmark appears next to the **Hide Disabled Settings** option to indicate that the software has hidden disabled settings.

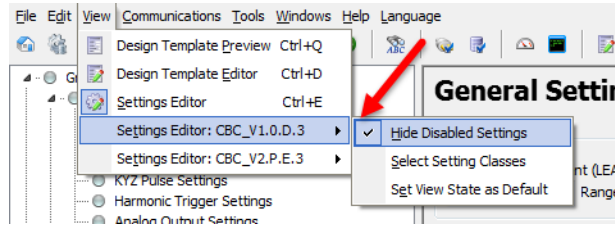

Figure 5.4 Settings Editor Views

This page intentionally left blank

Section 6

Commissioning

Overview

CAUTION

The front-panel terminal test jacks are for testing only. Do not attempt to power the device through these test jacks.

This section provides tips and instructions to verify that the SEL-734B Capacitor Bank Control is installed properly and is measuring the power system correctly.

Front-Panel Menu Structure

Table 6.1 shows the menu options available from the front panel, where you can view or change settings.

Table 6.1 Front-Panel Menu Structure (Sheet 1 of 2)

Menu Option	Submenu	Description
Meter	Instantaneous	Display instantaneous phase and sequence quantities, power factor, and power.
	Crest Factor	Display crest factor or reset value.
	Max/Min	Display Max/Min voltage, current, and power. Reset maximum and minimum values.
	Energy	Display energy quantities. Reset energy values.
	Demand/Peak	Display demand peak quantities.
	Harmonics	Display THD, K-Factor, and distortion power.
	Flicker	Display short-term and long-term flicker values.
	Transformer Line Losses	Display transformer losses and line losses. Refer to the <i>SEL-734 Instruction Manual</i> for details.
	Time Of Use	Display energy and demand of the present and previous season.
Events	Analog Inputs	Display analog inputs.
	Display Events	Display events.
Targets	Reset Events	Reset events.
		Display Device Word bits.
Status		Display device status, FID, part number, power supply status, battery voltage, and operating temperature.
Set/Show	Capacitor Controller Settings	Display or configure the design template settings. Please refer to the appropriate design template guide for details.
	Meter Settings	Set or show the Group 1 settings.
	Port Settings	Set or show Front Port, Port 1, Port 2, Port 3, or Port 4 settings.
	Global Settings	Set or show the Global settings.

Table 6.1 Front-Panel Menu Structure (Sheet 2 of 2)

Menu Option	Submenu	Description
	Front Panel Settings	Set or show front-panel settings.
	Date/Time	Set or show the date and time.
	Set Password	Set Access Level E and Access Level 2 passwords.

Verify the Measurements

This procedure explains how to check the metered values through different interfaces.

From the Front Panel

- Step 1. Press **ENT** on the front panel of the SEL-734B.
- Step 2. Select **Meter** and press **ENT**.
- Step 3. Select **Instantaneous** and press **ENT**.
- Step 4. Scroll through the menu to view the instantaneous measurements.

Using a Terminal Program

- Step 1. Establish communication to the SEL-734B.
- Step 2. Select the **ACSELERATOR QuickSet SEL-5030 Software Terminal** icon on the header ribbon or open a terminal program and establish SEL ASCII communication to the device.
- Step 3. Enter Access Level 1.
 - a. Enter the **ACC** command.
 - b. When prompted, enter the ACC password. The default password is **OTTER**.
- Step 4. Enter the **MET** command. The SEL-734B will report the instantaneous voltage, current, and power.

Using QuickSet HMI

- Step 1. Open the QuickSet HMI.
- Step 2. Navigate to the **Capacitor Bank Control Overview** window. The SEL-734B will report the instantaneous voltage, current, power factor, and power.

From the Front Terminal

Use a handheld volt meter connected to the front terminal test jacks to test the voltage.

Close and Open the Capacitor Bank From the Front Panel

The SEL-734B ships with the manual mode enabled by default. Manual mode allows you to operate the capacitor bank from the front panel.

- Step 1. Press the **MANUAL** pushbutton to ensure that manual mode is enabled.
- Step 2. On Compact Enclosure models, ensure that the **MANUAL** LEDs are illuminated. On the Full-Size Enclosure model, ensure that the **THREE-PHASE** LED is illuminated. If the **THREE-PHASE** LED is not illuminated, press the **MANUAL** pushbutton until it illuminates.
- Step 3. Press the **CLOSE** pushbutton. The **CLOSE COMMAND** LED should start flashing and the front-panel LCD should show the delayed time to close. Once the countdown reaches 0, the controller will close the capacitor bank.
- Step 4. Verify that all three switches closed.
- Step 5. Verify that the SEL-734B indicates the switches are closed and that no alarms are present.
- Step 6. Press the **OPEN** pushbutton. The **OPEN COMMAND** LED should start flashing and the front-panel LCD should show the delayed time to open. Once the countdown reaches 0, the controller will open the capacitor bank.

Close and Open the Capacitor Bank From the QuickSet HMI

The SEL-734B allows you to operate the capacitor bank from the QuickSet HMI page.

- Step 1. Establish communication with the SEL-734B.
- Step 2. Select the HMI icon on the header ribbon. QuickSet opens the HMI window.
- Step 3. Navigate to the Capacitor Bank Control Overview page, from the list on the left of the screen. The window will open.
- Step 4. Select **Enable/Disable HMI Mode**.
- Step 5. To close the capacitor switch, select the **CLOSE** pushbutton. The **CLOSE COMMAND** LED should start flashing.
- Step 6. Verify that the **CLOSE** LED is on to indicate the switches are closed and no alarms are present.
- Step 7. To open the capacitor switch, select the **OPEN** pushbutton. The **OPEN COMMAND** LED should start flashing.
- Step 8. Verify that the **OPEN** LED is on to indicate the switches are open and no alarms are present.

View the Sequential Events Recorder

After the controller operates the switches for the first time, you should view the Sequential Events Recorder (SER). Follow the instructions below to view the SER from the QuickSet HMI.

- Step 1. Open the QuickSet HMI.
- Step 2. Navigate to the **SER** window.
- Step 3. Choose the date range as appropriate.
- Step 4. Select the **Update SER** button.

QuickSet will poll the data from the SEL-734B and show the data in the window. QuickSet reports the SELOGIC element name in the SER report. Refer to the appropriate design template guide to determine the function of the SELOGIC element used for capacitor bank control. You can also complete the next steps to view an aliased SER report.

- Step 5. Select the **Aliased SER** button to view an aliased SER report. This shows the SELOGIC element function, instead of the SELOGIC element name, to the capacitor bank control algorithm. Please refer to your design template guide for further details.

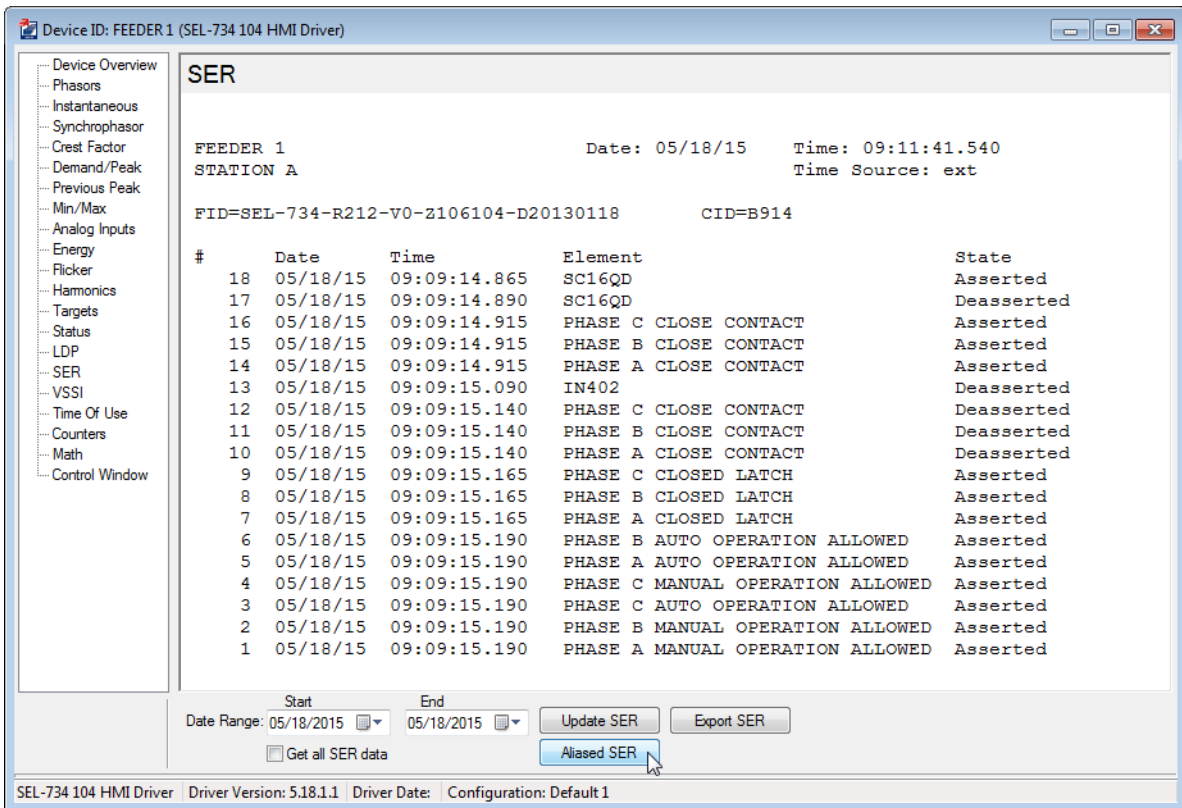

Figure 6.1 Aliased SER Report in QuickSet HMI

Validate SER

After the controller operates the bank for the first time, the sequence of events will be stored in memory. View the SER records as shown in the previous section, then use the following guidelines to ensure that the controller operated the capacitor bank properly.

Full-Size Enclosure

The Full-Size Enclosure contains three pairs of output contacts (three open contacts and three close contacts) to control three single-phase capacitor bank switches. Auxiliary 52a and 52b contacts can be connected to the SEL-734B enclosure, but these are optional.

Use the following guidelines to ensure the controller operates the switches properly.

- For a three-phase operation, ensure that all three output contacts operate simultaneously.
- For single-phase operations, ensure that only one output contact operates.
- Ensure each output contact remains asserted for a short duration, as configured.
- If the 52b contacts are connected to the enclosure, ensure the signal asserts when the switch is open. Ensure the signal deasserts when the switch is closed.
- If the 52a contacts are connected to the enclosure, ensure the signal deasserts when the switch is open. Ensure the signal asserts when the switch is closed.
- After each operation, ensure the SEL-734B indicates the proper switch status.

Compact Enclosure

Compact enclosures contain one open contact and one close contact to control one three-phase switch, or three single-phase switches that are electrically connected. The Compact Enclosure does not connect to the switch auxiliary contacts.

Please use the following guidelines to ensure the controller operates the switches properly.

- Verify output contacts operate properly.
- Ensure each output contact remains asserted for the configured duration.
- After each operation, ensure the SEL-734B indicates the proper switch status.

Troubleshooting and Common Problems

CLOSE or OPEN Button Does Not Respond

- Check that the manual mode is enabled. Press the **MANUAL** pushbutton to enable this mode.
- Check that the control power is healthy.
 - Check that the control power fuse located on the inside of the enclosure has continuity.
 - Check that 120 Vac is present. Refer to the enclosure wiring and check that 120 Vac voltage is present between the control power fuse and neutral.
 - Check the front panel. Refer to the appropriate design template guide to check the SEL-734B indicators of control power.
- Check that an overvoltage or high neutral current does not exist. To protect the switches and the capacitor bank, the controller will not close a switch if an overvoltage or a high neutral current condition exists. Refer to the appropriate design template guide to check the SEL-734B lockout indicators.

Full-Size Enclosure Design Templates

Update Phase A, Phase B, and Phase C Operation Counter Values

Before sending new settings to the SEL-734B from a PC, modify the values of the operation counters in QuickSet Settings to match the current counter values. This is important to ensure that the counter values on the settings file stored in the PC do not override the current counter values on the SEL-734B.

Perform the following steps to change the counter values on QuickSet settings.

- Step 1. Obtain the current counter values for Phase A, Phase B, and Phase C. Obtain the counter values by using one of the two following methods.

Method 1–Front-Panel Display

The current values of the counter are part of the rotating front-panel LCD messages under the labels shown in *Figure 6.2*.

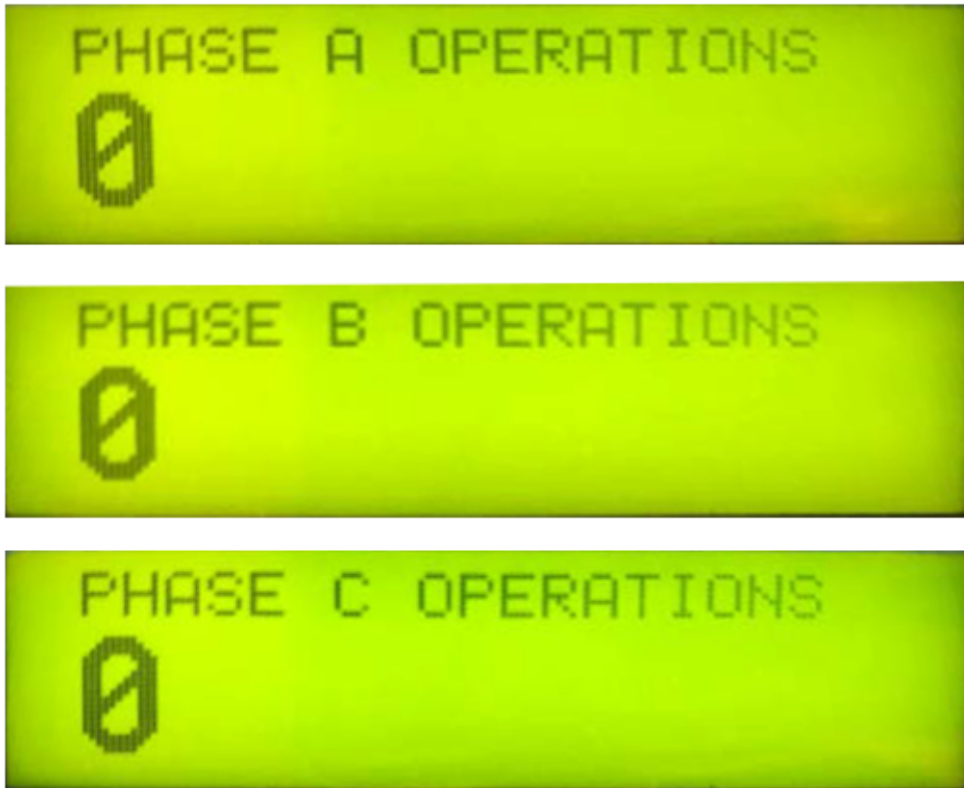

Figure 6.2 Operation Counters on the Rotating Front-Panel LCD

Method 2–Terminal

The current counter values can also be obtained by using the **COU** command on the terminal window and recording the values of SC11 (Phase A counter), SC14 (Phase B counter), and SC24 (Phase C counter). At a minimum, you need to be at Access Level 1 to obtain the counter values.

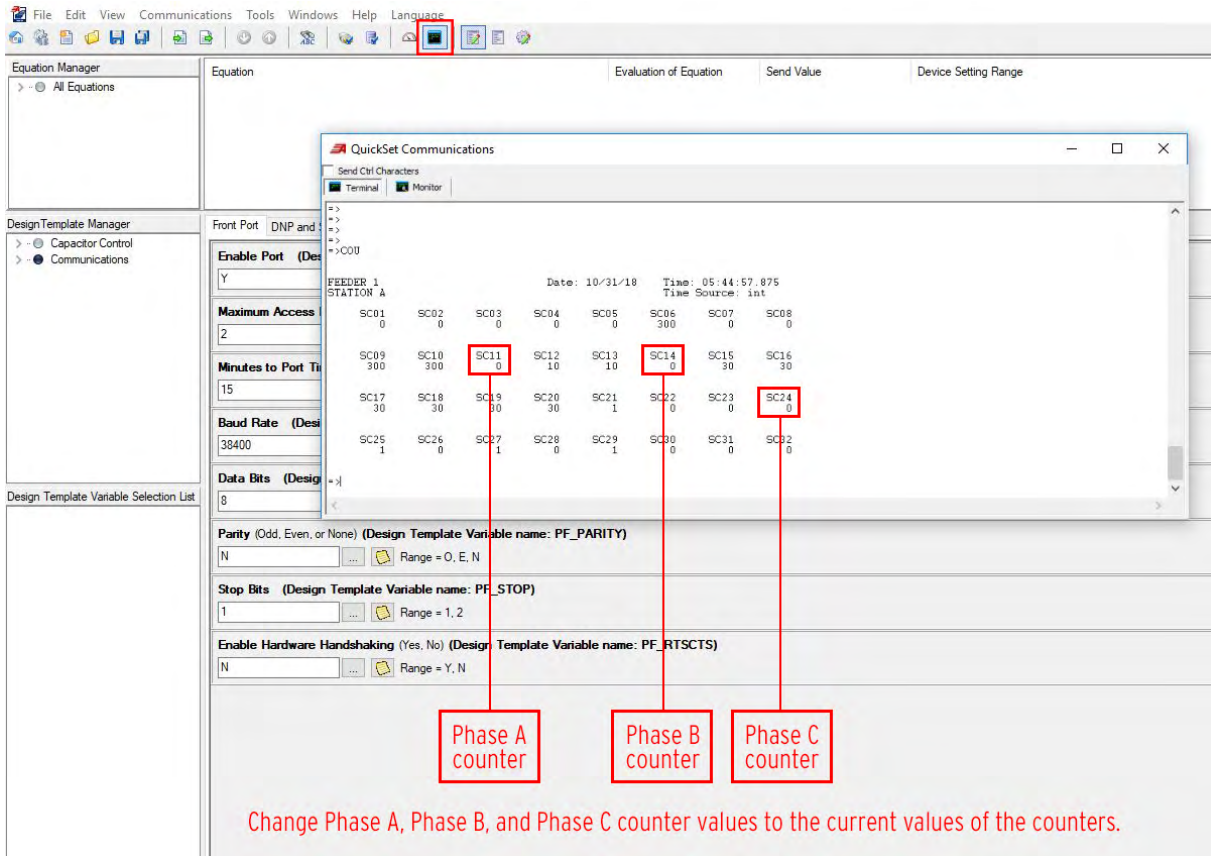

Figure 6.3 Counter Values Obtained Via QuickSet Terminal

- Step 2. Navigate to the settings editor view by selecting the settings editor icon on the toolbar ribbon. Alternatively, typing <Ctrl+E> on a PC keyboard also takes you to the settings editor.
- Step 3. Navigate to **Group 1 > Logic 1 > SELogic Counter Equations** to access the operation counters for each of the three phases.

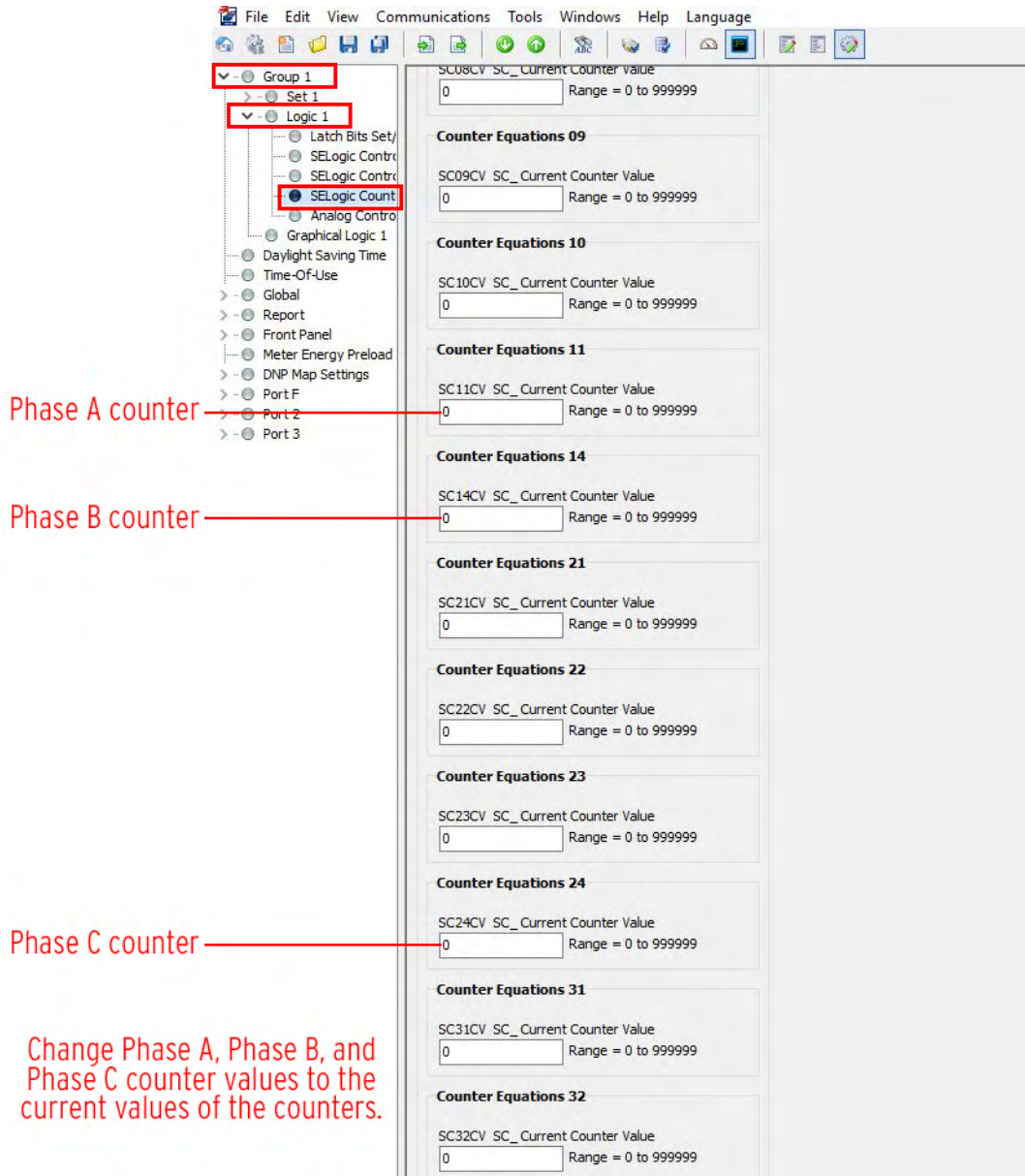

Figure 6.4 SELogic Counter Equations Settings in the Settings Editor View

Step 4. Enter the current value of the operation counter obtained in *Step 1* into the boxes indicated in *Figure 6.4*.

Step 5. Save the settings.

The settings are now ready to send to the device.

This page intentionally left blank

Section 7

Maintenance

Visual changes may occur on fiberglass enclosures when they are exposed continually to environmental elements such as ultraviolet (UV) light, humidity, wind, and rain. Some of these changes are surface appearance changes, apparent color change (also called yellowing), and gloss loss. This happens because the ultraviolet light causes oxidation of the polyester resins used in the fiberglass enclosure, resulting initially in a powder like appearance and eventually in a snowflake like appearance on the outside of the enclosure. After a period of time, and under repeated exposure to these environmental elements, the reinforcing fibers may become exposed to the surface, resulting in a phenomenon called fiber bloom. Without any surface protection like wax and/or paint, this process can happen within the first two to five years, depending on the severity of the conditions. Fiber bloom is primarily an aesthetic condition. It should not affect the physical properties of the cabinet in an appreciable manner. Fiber bloom can also result in abrasions to personnel working with the enclosure.

Several factors affect the rate at which these changes progress on the enclosure:

- **Geographic Location.** Typically, an enclosure installed in tropical climates that sees high exposure to sun and humidity will see a more pronounced effect than other places. For example, an enclosure installed in Florida may see a more visible effect than an enclosure installed in Indiana.
- **Maintenance.** The type of protection applied and the time between repeated applications should be determined by the customer's personnel familiar with the local climate. Two types of protection are suggested here: painting and waxing. Painting offers better protection than waxing and, if properly applied, lasts longer than wax. Waxing is a simpler process than painting. However, it does not offer protection against ultraviolet light.

SEL recommends the following maintenance procedures to counteract the effects of fiber bloom.

1. **Painting.** Painting is a more involved process than waxing, but is known to provide effective resistance to fiber bloom. The following guides may be followed when painting the enclosures:
 - Rough up the surface by lightly rubbing with sandpaper.
 - Degrease the surface with an organic solvent such as alcohol or other domestic cleaning agent.
 - Wait for the surface to be clean and dry.
 - Apply the appropriate primer and top coat.

Some general recommendations for paints are acrylic lacquer, a clear acrylic polyurethane, and Rust-Oleum universal formula spray paint.

2. **Waxing.** Waxing is recommended semi-annually, especially for areas that see significantly high exposure to the previously mentioned environmental elements. Any good commercially available wax like Carnauba paste wax can be used here. Note that although waxing provides protection against humidity, it offers almost no protection against ultraviolet light. Also, waxing is not meant to be a replacement for painting, but can be considered as a supplement to painting.

Note that appropriate personal protective equipment (PPE) such as glasses, a mask or gloves is recommended for the person doing the maintenance.

Appendix A

Field Reference Guide Versions

The date code at the bottom of each page of this manual reflects the creation or revision date.

Table A.1 lists the field reference guide release dates and a description of modifications. The most recent revisions are at the top of the list.

Table A.1 Revision History (Sheet 1 of 3)

Date Code	Summary of Revisions
20231206	<p>Section 1</p> <ul style="list-style-type: none"> ➤ Updated <i>Figure 1.2: SEL-734B Front Panel</i>. ➤ Added <i>Temperature Sensor Input Board</i>. ➤ Added <i>SEL-3061 Cellular Router</i>. ➤ Updated <i>SEL-2401 Satellite-Synchronized Clock</i>. ➤ Updated <i>Open Door Indications</i>. <p>Section 2</p> <ul style="list-style-type: none"> ➤ Updated <i>Combined Sensor Connector Version</i>. ➤ Updated <i>Individual Sensor Connector Versions</i>. ➤ Updated <i>Figure 2.4: Bottom View of Connectorized Compact Enclosure</i>. ➤ Updated <i>Figure 2.5: Bottom View of Terminal Block Enclosure</i>. ➤ Updated <i>Table 2.12: Pinout of Control, Power, and Sensor Cable J1 for 7-Pin Connectorized Enclosure</i>. <p>Section 5</p> <ul style="list-style-type: none"> ➤ Updated <i>Table 5.1: Control Features of Enclosure Models</i>. <p>Appendix E</p> <ul style="list-style-type: none"> ➤ Updated all enclosure drawings. ➤ Added <i>Figure E.9: Compact 7-Pin Terminal Block Connector Enclosure Schematic Diagram</i> through <i>Figure E.14: Full-Size Individual Sensor Connector Enclosure Point-to-Point Wiring Diagram</i>.
20230608	<p>Section 1</p> <ul style="list-style-type: none"> ➤ Updated <i>Serial and Ethernet Patch Cables in Enclosure Front</i>. ➤ Removed <i>SEL-3060 Ethernet Radio</i> from <i>Enclosure Front</i>. <p>Appendix E</p> <ul style="list-style-type: none"> ➤ Updated <i>Figure E.1: Compact 4-Jaw Socket-Based Enclosure Schematic Diagram</i> through <i>Figure E.6: Compact 6-Jaw Option B Socket-Based Enclosure Point-to-Point Wiring Diagram</i>.
20210527	<p>Section 5</p> <ul style="list-style-type: none"> ➤ Updated <i>Table 5.1: Control Features of Enclosure Models</i>.
20200813	<p>Section 2</p> <ul style="list-style-type: none"> ➤ Added 7-position terminal block enclosure. <p>Section 3</p> <ul style="list-style-type: none"> ➤ Updated <i>Figure 3.3: Compact 7-Pin Enclosure Mounting Dimensions</i>. <p>Section 5</p> <ul style="list-style-type: none"> ➤ Updated <i>Table 5.1: Control Features of Enclosure Models</i>. <p>Appendix C</p> <ul style="list-style-type: none"> ➤ Updated <i>Compact 7-Pin Enclosures</i>. <p>Appendix E</p> <ul style="list-style-type: none"> ➤ Updated <i>Figure E.7: Compact 7-Pin Enclosure Schematic Diagram</i>.

Table A.1 Revision History (Sheet 2 of 3)

Date Code	Summary of Revisions
20200709	<p>Section 2</p> <ul style="list-style-type: none"> ▶ Updated <i>Check the Status of the Controller Using QuickSet</i>. <p>Section 6</p> <ul style="list-style-type: none"> ▶ Added <i>Close and Open the Capacitor Bank From the QuickSet HMI</i>.
20181214	<p>Section 1</p> <ul style="list-style-type: none"> ▶ Updated power supply board information in <i>SEL-734B Rear Panel</i>. <p>Section 3</p> <ul style="list-style-type: none"> ▶ Updated <i>Figure 3.4: Meter Locking Ring for Socket-Based Enclosure</i>. <p>Section 5</p> <ul style="list-style-type: none"> ▶ Updated <i>Table 5.1: Control Features of Enclosure Models</i>. <p>Section 6</p> <ul style="list-style-type: none"> ▶ Added <i>Full-Size Enclosure Design Templates</i>.
20180720	<p>Appendix B</p> <ul style="list-style-type: none"> ▶ Updated <i>Table B.1: Compact Socket-Based Enclosure Revision History</i>. <p>Appendix E</p> <ul style="list-style-type: none"> ▶ Updated <i>Figure E.1: Compact 4-Jaw Socket-Based Enclosure Schematic Diagram</i> through <i>Figure E.6: Compact 6-Jaw Option B Socket-Based Enclosure Point-to-Point Wiring Diagram</i>.
20180629	<p>General</p> <ul style="list-style-type: none"> ▶ Added <i>Section 7: Maintenance</i>.
20170207	<p>Section 1</p> <ul style="list-style-type: none"> ▶ Updated <i>Voltage and Current Measurement Board</i> in <i>SEL-734B Rear Panel</i>. ▶ Added <i>SEL-3031 Serial Radio</i> in <i>Enclosure Front</i>. <p>Section 2</p> <ul style="list-style-type: none"> ▶ Updated <i>Table 2.4: Sensor Cables for Full-Size Enclosures With the Combined Sensor Connector</i>. ▶ Updated <i>Table 2.8: Power Supply/Neutral Sensor Control Cables for Full-Size Enclosures With Individual Sensor Connectors</i>. ▶ Updated <i>Table 2.10: Sensor Cables for Full-Size Enclosures With Individual Sensor Connectors</i>. ▶ Updated <i>Figure 2.4: Bottom View of Connectorized Compact Enclosure</i>. <p>Section 3</p> <ul style="list-style-type: none"> ▶ Updated <i>Pole-Mounting the Full-Size and Compact 7-Pin Enclosures</i>. ▶ Updated <i>Figure 3.2: Full-Size Enclosure Mounting Dimensions</i>. ▶ Updated <i>Figure 3.3: Compact 7-Pin Enclosure Mounting Dimensions</i>. <p>Section 5</p> <ul style="list-style-type: none"> ▶ Updated <i>Table 5.1: Control Features of Enclosure Models</i>. <p>Appendix C</p> <ul style="list-style-type: none"> ▶ Updated <i>Full-Size Enclosures With the Combined Sensor Connector</i> and <i>Full-Size Enclosures With Individual Sensor Connectors</i>. <p>Appendix F</p> <ul style="list-style-type: none"> ▶ Updated <i>Full-Size Enclosure Accessories</i>.
20161006	<p>General</p> <ul style="list-style-type: none"> ▶ Revised compact enclosure information. ▶ Added <i>Appendix B: Cabinet Revisions</i>. ▶ Added <i>Appendix F: Accessories</i>. <p>Section 1</p> <ul style="list-style-type: none"> ▶ Updated <i>Figure 1.1: SEL-734B Model Options in Outdoor-Rated Enclosures</i>. ▶ Updated <i>SEL-734B Rear Panel</i>. ▶ Updated <i>Figure 1.4: UPS With Integrated 15 Vdc Power Supply for Accessories</i>. ▶ Added <i>Enclosure Front</i> subsection.

Table A.1 Revision History (Sheet 3 of 3)

Date Code	Summary of Revisions
	<p>Section 2</p> <ul style="list-style-type: none"> ➤ Updated <i>Figure 2.1: Bottom View of Enclosure With the Combined Sensor Connector</i> through <i>Figure 2.3: 4- and 6-Jaw Socket Stabs</i>. ➤ Updated <i>Table 2.6: Pinout of Control Connector J1 for Enclosures With Individual Sensor Connectors</i>. ➤ Updated <i>Notes</i> column in tables describing SEL cable options. ➤ Updated <i>Table 2.11: Socket Stab Configurations</i>. <p>Section 3</p> <ul style="list-style-type: none"> ➤ Added <i>Figure 3.1: SEL-734B Customer Ground Connections to Required System Grounding</i>. <p>Section 5</p> <ul style="list-style-type: none"> ➤ Updated <i>Table 5.1: Control Features of Enclosure Models</i>. <p>Appendix C</p> <ul style="list-style-type: none"> ➤ Updated <i>Figure C.1: Full-Size Enclosure With Combined Measurement Connector</i> through <i>Figure C.7: Compact 7-Pin Enclosure</i>. <p>Appendix E</p> <ul style="list-style-type: none"> ➤ Updated <i>Figure E.1: Compact 4-Jaw Socket-Based Enclosure Schematic Diagram</i> through <i>Figure E.8: Compact 7-Pin Connectorized Enclosure Point-to-Point wiring Diagram</i>.
20150730	<ul style="list-style-type: none"> ➤ Initial version.

This page intentionally left blank

Appendix B

Compact Socket-Based Enclosure Revisions

Table B.1 lists the version and release dates of cabinet variants for the compact socket-based enclosure.

Table B.1 Compact Socket-Based Enclosure Revision History

Revision Date	Summary of Revisions
20180720	<ul style="list-style-type: none"> ▶ Compact 4-Jaw, 6-Jaw Option A, and 6-Jaw Option B schematic diagrams and point-to-point wiring drawings updated with the following changes: <ul style="list-style-type: none"> ➤ E02, E03, and E04 jumpered. ➤ E02 and E03 isolated from CPT neutral. <p>These changes apply to <i>Figure E.1, Figure E.2, Figure E.3, Figure E.4, Figure E.5 and Figure E.6.</i></p>
20160901	<ul style="list-style-type: none"> ▶ Added 6-Jaw Option B wiring configuration. ▶ Added ground lug with MOV isolation between ground and neutral. ▶ Increased to 6 kV surge for power supply mains. ▶ Added door switch. ▶ Added optional accessory tray. ▶ Moved socket base to offset from center for ease of locking ring installation.
	<ul style="list-style-type: none"> ▶ Initial version.

This page intentionally left blank

Appendix C

Installation Examples

Full-Size Enclosures With the Combined Sensor Connector

Figure C.1 shows a diagram of a typical installation of the Full-Size Enclosure model with the combined sensor connector.

Ground Conductor

Ground the SEL-734B Capacitor Bank Control cabinet by using the ground lug before making any other connections to the cabinet.

Sensor Cable

The sensor cable connects to the 14-pin connector on the bottom of the enclosure. Three measurement legs connect to three combination sensors to measure voltage and current on each phase. Certain sensor cables also connect to a neutral current sensor. The Lindsey Manufacturing Company R-22748/XX,YY cable connects to three Lindsey combination sensors and one Lindsey neutral sensor (as shown in *Figure C.1*).

Both the Lindsey 9-587/XX/R-22102 and SEL-C529 cables connect to three Lindsey Manufacturing Co. combination sensors. The SEL-C536 cable connects to three Piedmont LSCV-SEL sensors. When using a sensor cable that does not include the neutral sensor connection, a separate neutral sensor cable may be routed through the bottom of the enclosure and connected to terminal blocks inside the enclosure (see the Combined Sensor enclosure wiring diagram available at selinc.com). This sensor arrangement is shown in *Figure C.2*.

Control Cable

The control cable connects to the 19-pin connector on the bottom of the enclosure. One leg of the cable connects to the control power transformer, which powers the SEL-734B and provides operating power to the switches. Each of the other three legs connects to a capacitor bank switch.

The SEL-C543 cable connects to three 5-pin switches and the control power transformer, and it supports 52b auxiliary contact monitoring. The SEL-C544 cable is similar to the SEL-C543 cable, but it connects to 6-pin switches and supports 52a and 52b auxiliary contact monitoring. The SEL-C547 cable is similar to the SEL-C544 cable, but it connects to 7-pin switches. An installation using these cables is shown in *Figure C.1*.

Alternatively, the SEL-734B may be connected to the switches through a Cooper CCR116K1 junction box. An SEL-C556 cable connects the SEL-734B to the junction box, and SEL-C526 cables connect each switch to the junction box (as shown in *Figure C.2*). SEL does not offer a cable to connect the CCR116K1 to the control power transformer.

C.2 | Installation Examples
Full-Size Enclosures With the Combined Sensor Connector

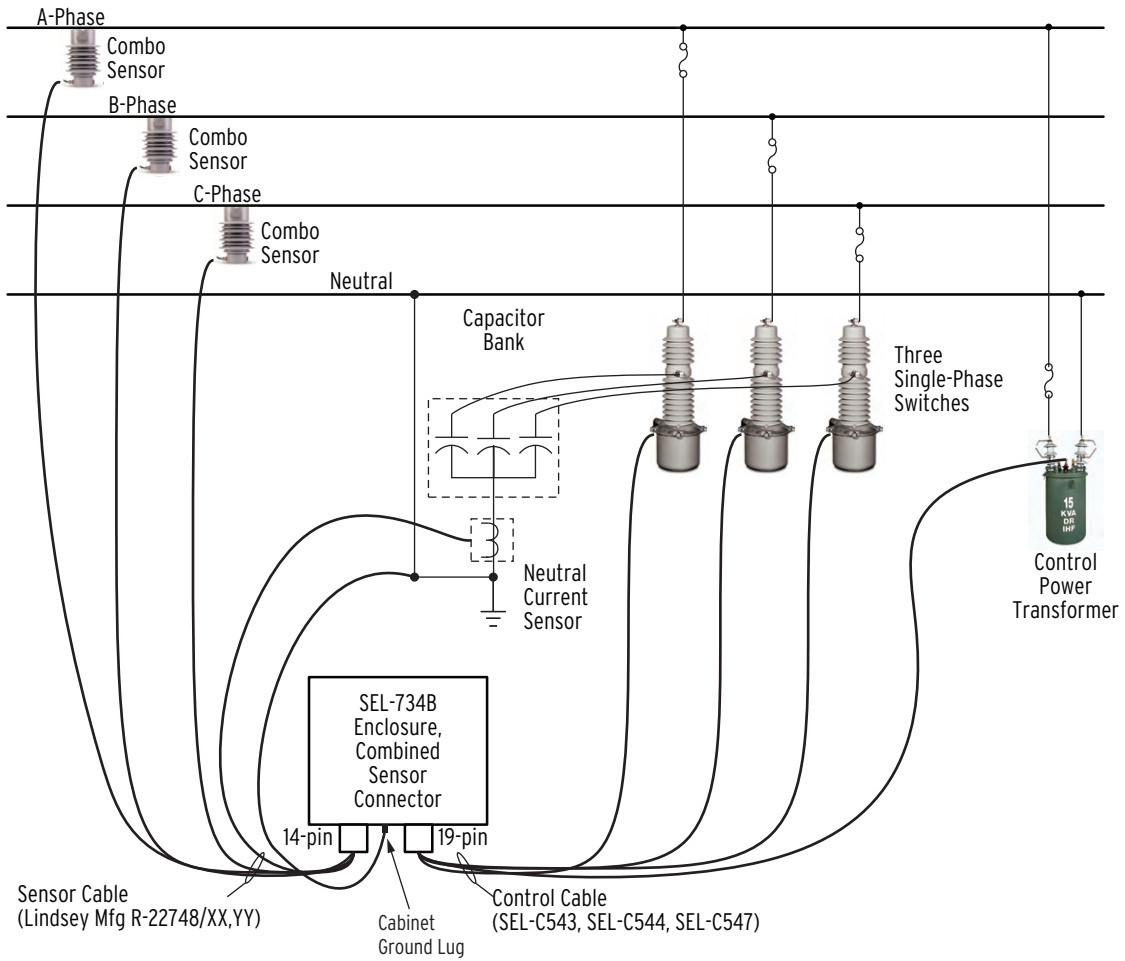

Figure C.1 Full-Size Enclosure With Combined Sensor Connector (With a Single Cable for Phase and Neutral Sensors)

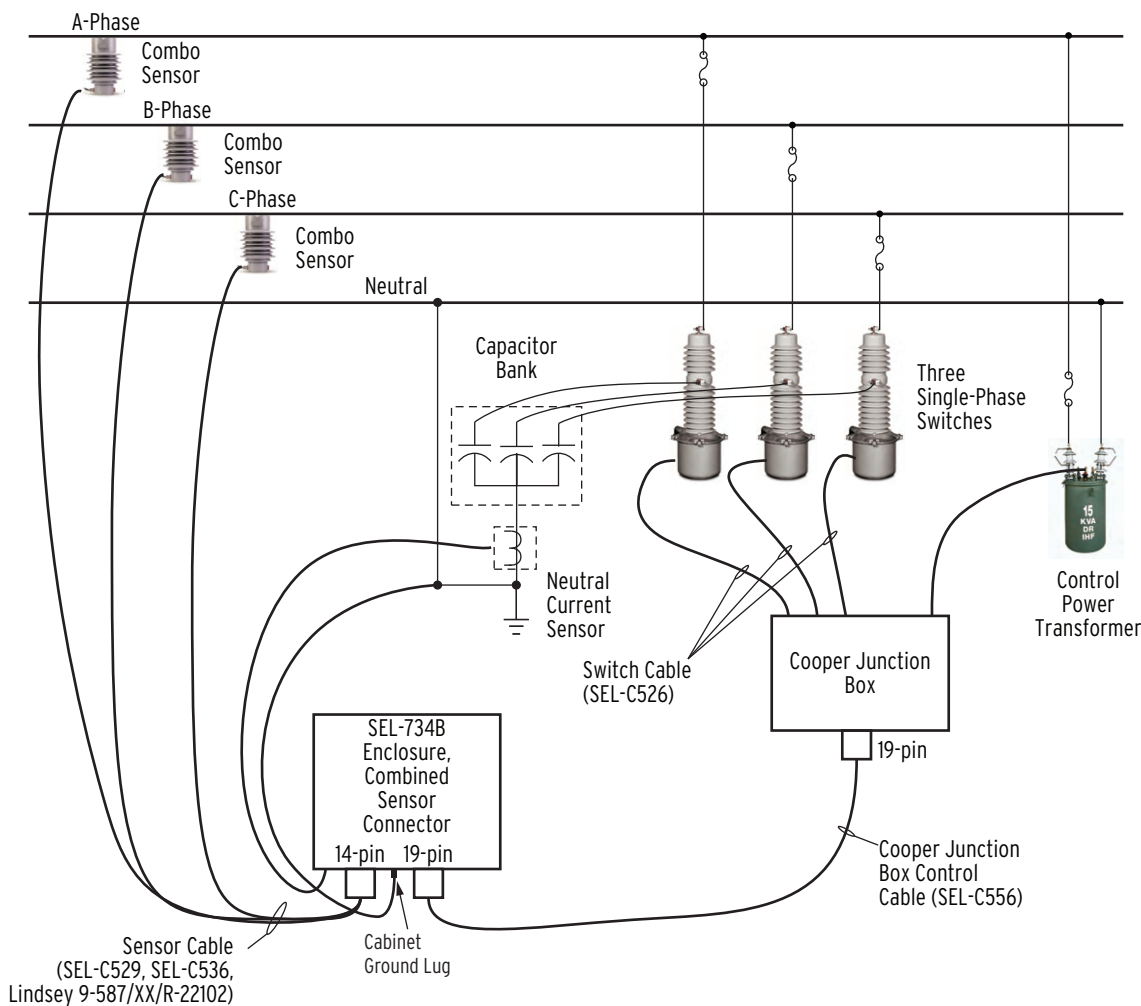

Figure C.2 Full-Size Enclosure With Combined Sensor Connector (Installed With Cooper Junction Box and Separate Neutral Sensor Cable)

Full-Size Enclosures With Individual Sensor Connectors

Figure C.3 shows a diagram of a typical installation of the Full-Size Enclosure model with individual sensor connectors.

Ground Conductor

Ground the SEL-734B Capacitor Bank Control cabinet by using the ground lug before making any other connections to the cabinet.

Sensor Cables

One measurement cable connects to one combination sensor. For three-phase sensing, connect all three sensors to the enclosure (see Figure C.3 and Figure C.4). If sensing only a single phase, install SEL-C530S shorting plugs into the unused connectors to short them to neutral and minimize noise (see Figure C.5).

The SEL-C530 cable connects to a single Lindsey Manufacturing Co. combination sensor. The Lindsey 9-587/XX/9-582 cable can be used as an alternative.

Power Supply/Neutral Sensor Cable

The power supply/neutral sensor cable connects to the 4-pin military standard connector on the bottom of the enclosure.

The SEL-C532 cable provides a pigtail to connect to the control power transformer and a neutral sensor (see *Figure C.3* and *Figure C.5*). The SEL-C539 cable provides a pigtail to connect to the control power transformer, and a 4-pin connector to plug into a Lindsey R-Z2981SS cable and neutral sensor (see *Figure C.4*).

Control Cable

The control cable connects to the 19-pin connector on the bottom of the enclosure. Each of the three cable legs connects to a single-phase capacitor bank switch. Control power is provided through the power supply/neutral sensor cable, and not the control cable.

The SEL-C531 cable connects to three 5-pin switches, but additionally supports 52a and 52b auxiliary contact monitoring. The SEL-C538 cable connects to three 6-pin switches and supports 52a and 52b auxiliary contact monitoring.

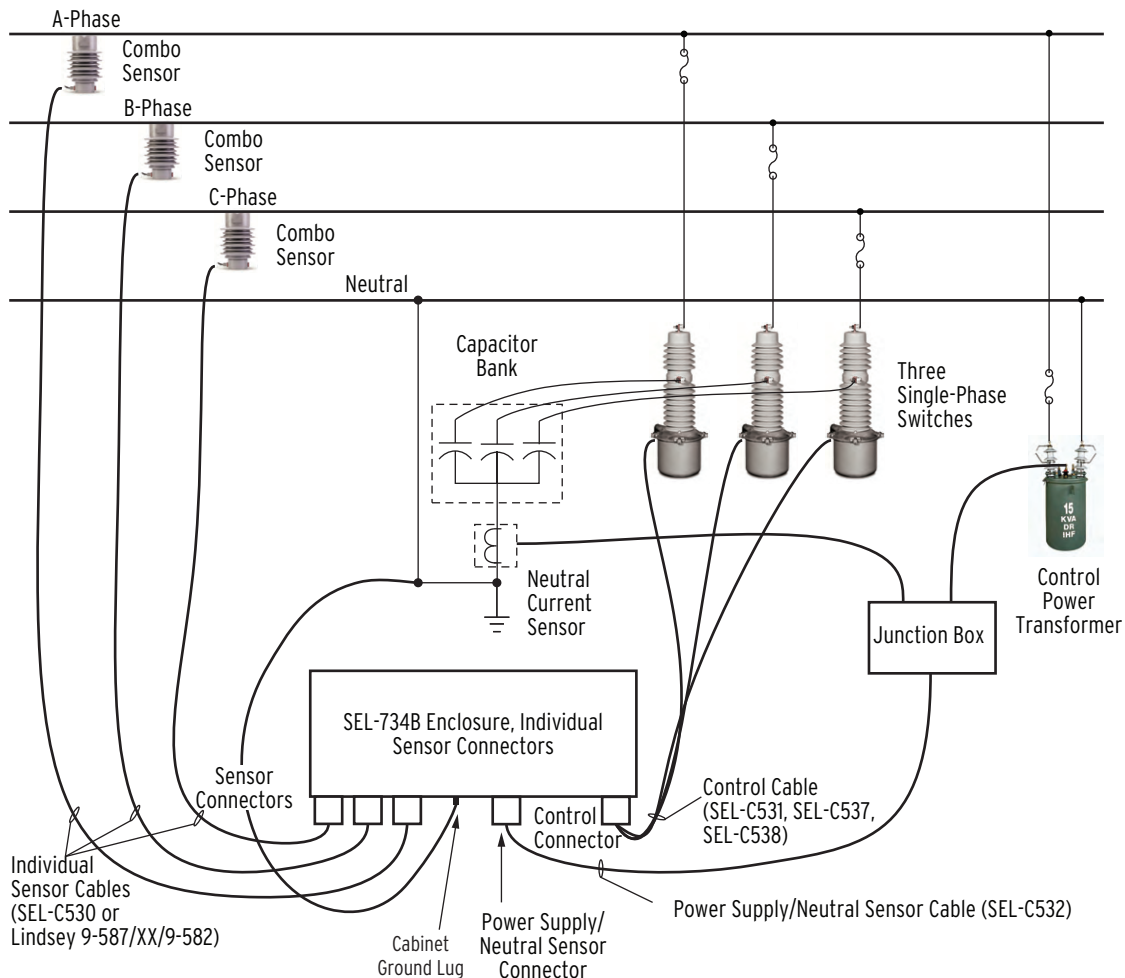

Figure C.3 Full-Size Enclosure With Individual Sensor Connectors (Installed With a Generic Neutral Current Sensor)

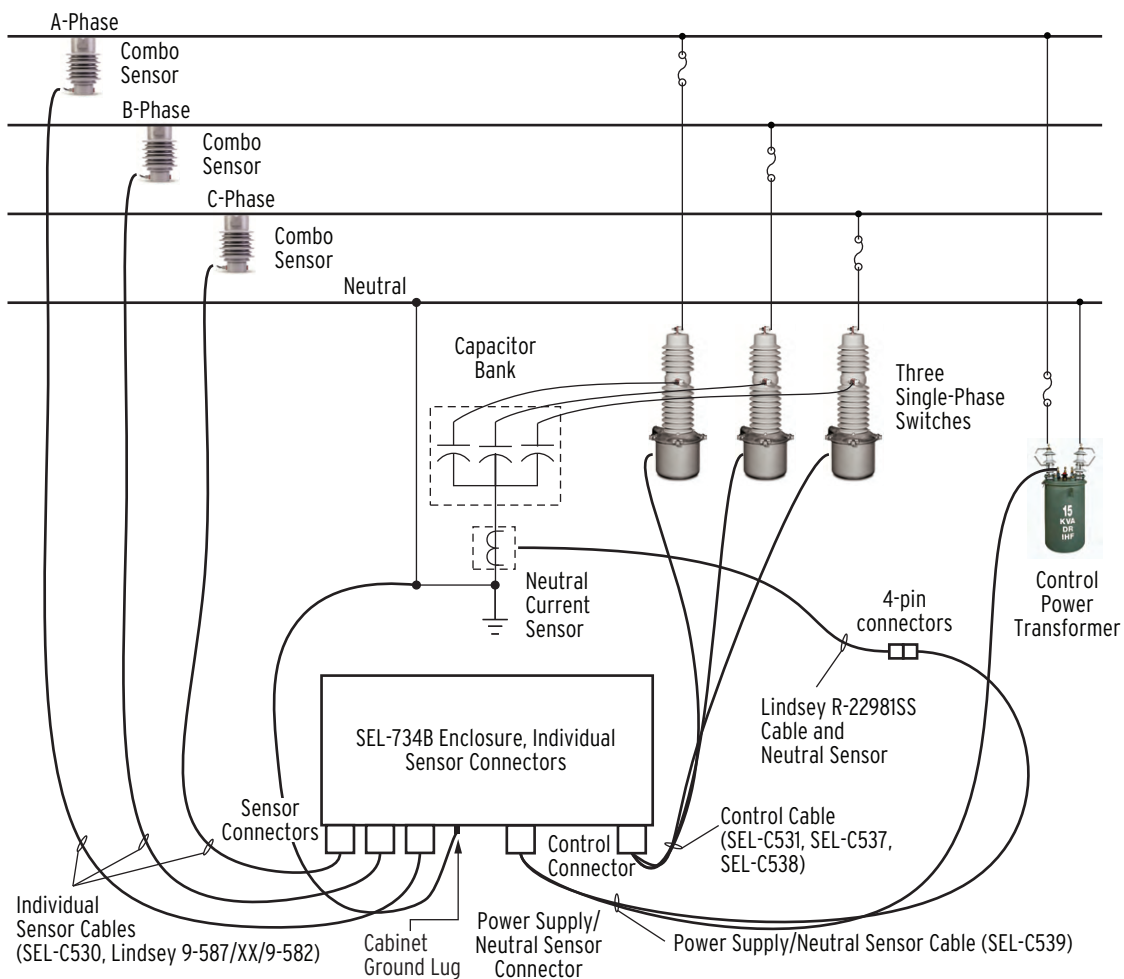

Figure C.4 Full-Size Enclosure With Individual Sensor Connectors (Installed With a Lindsey Neutral Current Sensor)

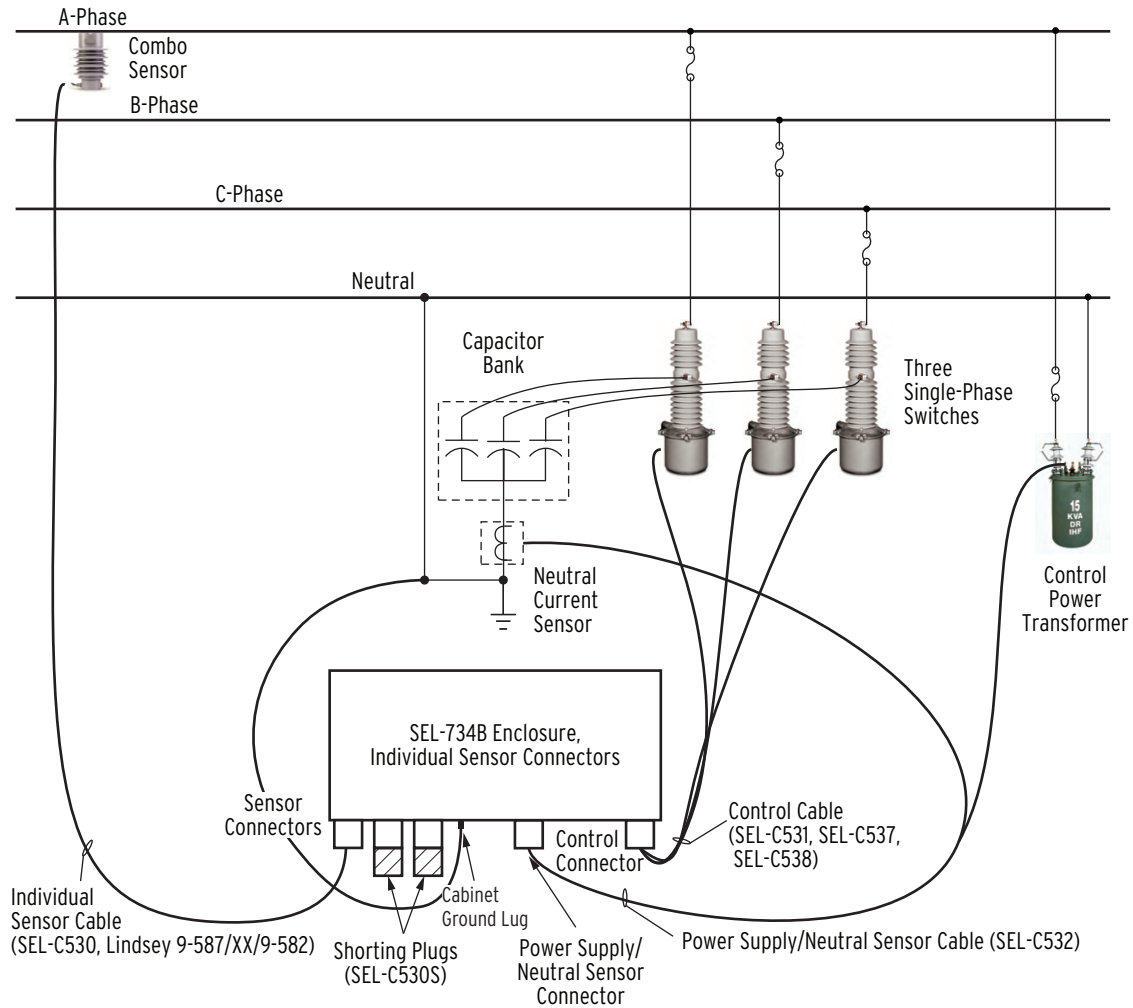

Figure C.5 Full-Size Enclosure With Individual Sensor Connectors (Installed With a Single Sensor and Generic Neutral Current Sensor)

Compact 7-Pin Enclosures

Figure C.6 shows a diagram of a typical installation of the Compact 7-Pin Enclosure. Ground the SEL-734B Capacitor Bank Control cabinet chassis before making any other connections to the cabinet.

For a Connectorized enclosure, the SEL-C548 cable connects to a 120 Vac control power transformer, a three-phase capacitor bank switch, one current sensor, and one neutral current sensor. A 7-pin circular connector mates with the enclosure, and a weather-tight seal mounts to a penetration on the junction box.

For a 7-position terminal block enclosure, use a passthrough cable to wire directly to the terminal block in the SEL-734B without a connector. Similar to the Connectorized version, connect the other end to a 120 Vac control power transformer, a three-phase capacitor switch, a neutral current sensor, and a one-phase current sensor.

The SEL-734B measures the output voltage of the control power transfer and uses the signal for capacitor bank control. The current sensor should be installed on the same phase on which the control power transformer is installed.

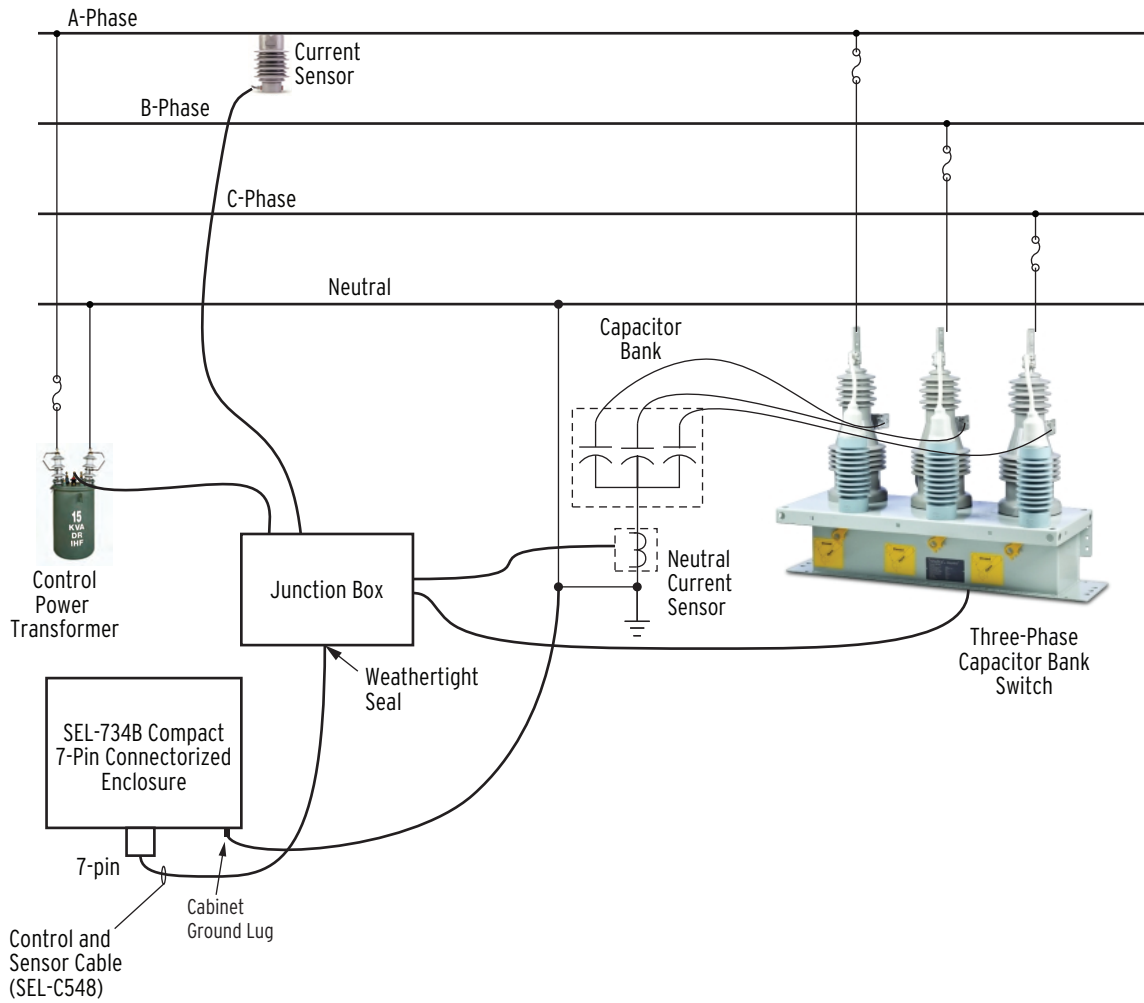

Figure C.6 Compact 7-Pin Connectorized Enclosure

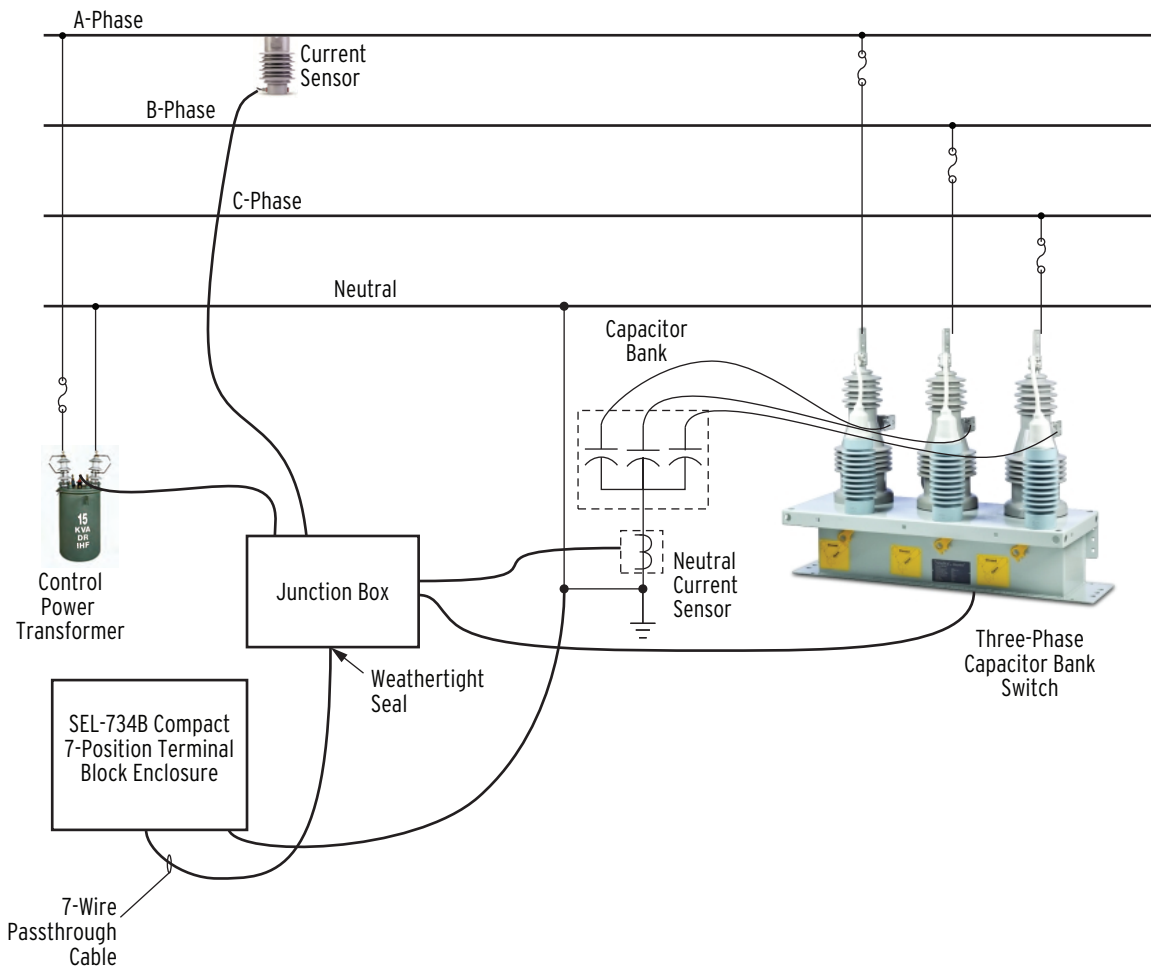

Figure C.7 Compact 7-Position Terminal Block Enclosure

Compact Socket-Based Enclosures

Figure C.8 shows a diagram of a typical installation of the Compact 6-Jaw Option A Enclosure (6-Jaw Option B and 4-Jaw installations are similar). This installation is similar to the Compact 7-Pin Enclosure, except that all field connections are made through a socket instead of a cable and junction box. Ground the SEL-734B Capacitor Bank Control cabinet before making any other connections to the cabinet.

The enclosure plugs into the meter socket base, which provides all of the connections to the field devices. SEL does not provide the cabling to connect the field devices to the meter socket base.

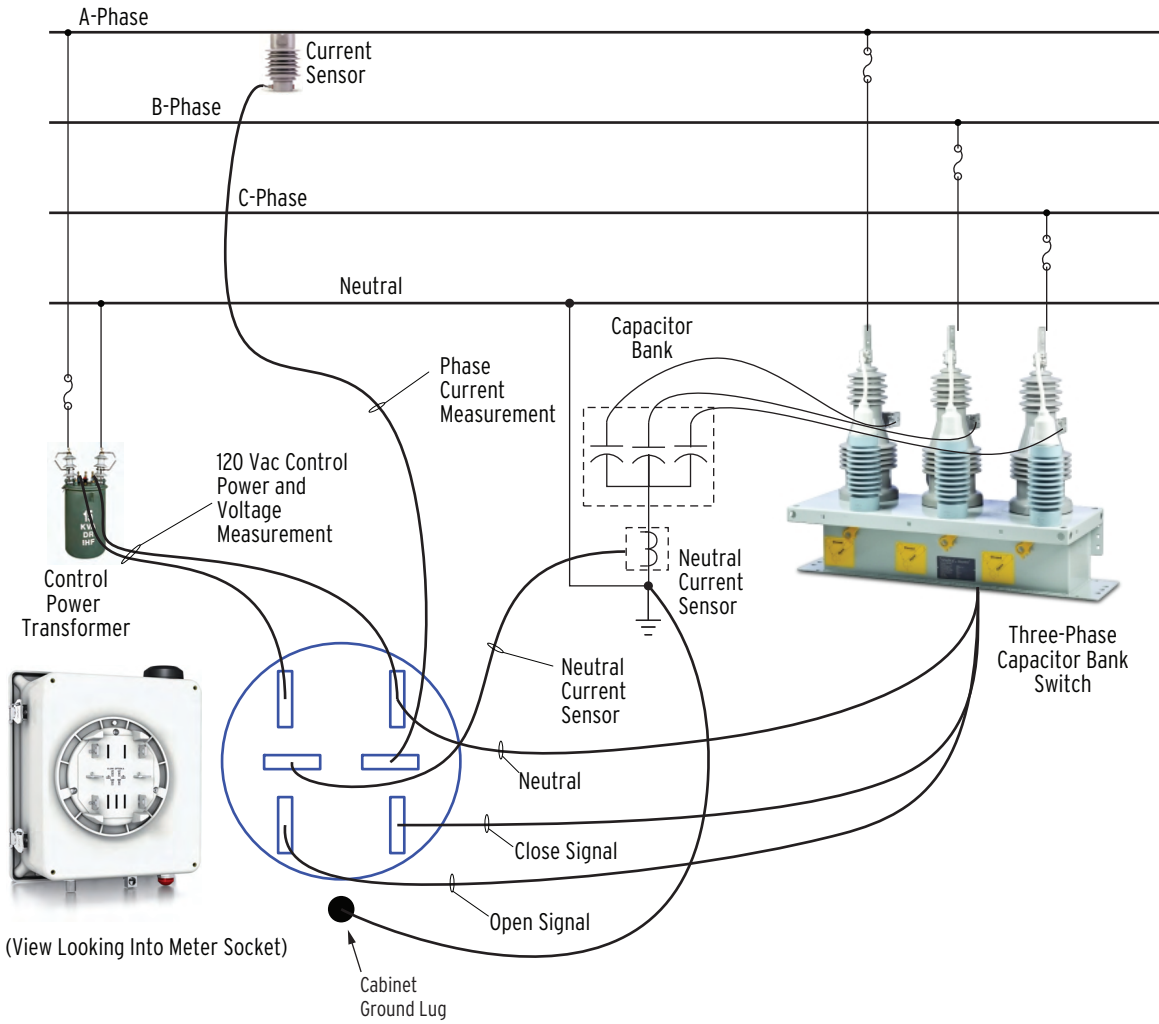

Figure C.8 Compact 6-Jaw Option A Socket-Based Enclosure Connection Diagram

This page intentionally left blank

Appendix D

Cable Drawings

This appendix includes cable drawings for each enclosure style.

Control Cables for Full-Size Enclosures With the Combined Sensor Connector

SEL-C543

Cable SEL-C543 connects to three switches and the control power transformer (5-pin female connectors).

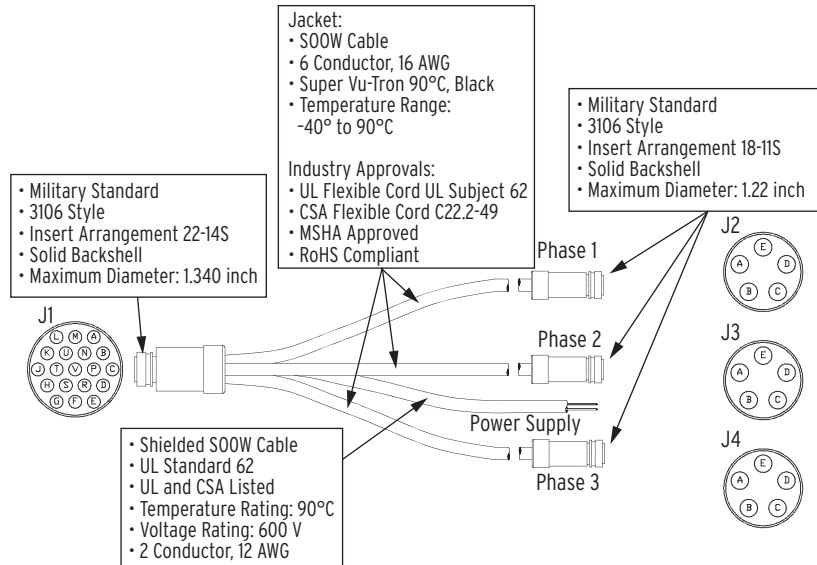

Connector Pin	Wire Color	Wire Type	Function		Connector Pin
J1-A	Black	#12 AWG 65/30 Strand	Power Supply	120 VAC	Wire Termination
J1-B	White	#12 AWG 65/30 Strand		Neutral	Wire Termination
J1-U	Red	#16 AWG 26/30 Strand	Phase 1	Common	J2-A
J1-E	White	#16 AWG 26/30 Strand		Common	J2-B
J1-D	Green	#16 AWG 26/30 Strand		Close	J2-C
J1-C	Black	#16 AWG 26/30 Strand		Open	J2-D
J1-N	Orange	#16 AWG 26/30 Strand		52b	J2-E
J1-U	Red	#16 AWG 26/30 Strand	Phase 2	Common	J3-A
J1-H	White	#16 AWG 26/30 Strand		Common	J3-B
J1-G	Green	#16 AWG 26/30 Strand		Close	J3-C
J1-F	Black	#16 AWG 26/30 Strand		Open	J3-D
J1-R	Orange	#16 AWG 26/30 Strand		52b	J3-E
J1-U	Red	#16 AWG 26/30 Strand	Phase 3	Common	J4-A
J1-L	White	#16 AWG 26/30 Strand		Common	J4-B
J1-K	Green	#16 AWG 26/30 Strand		Close	J4-C
J1-J	Black	#16 AWG 26/30 Strand		Open	J4-D
J1-T	Orange	#16 AWG 26/30 Strand		52b	J4-E

SEL-C544

Cable SEL-C544 connects to three switches and the control power transformer (6-pin female connectors).

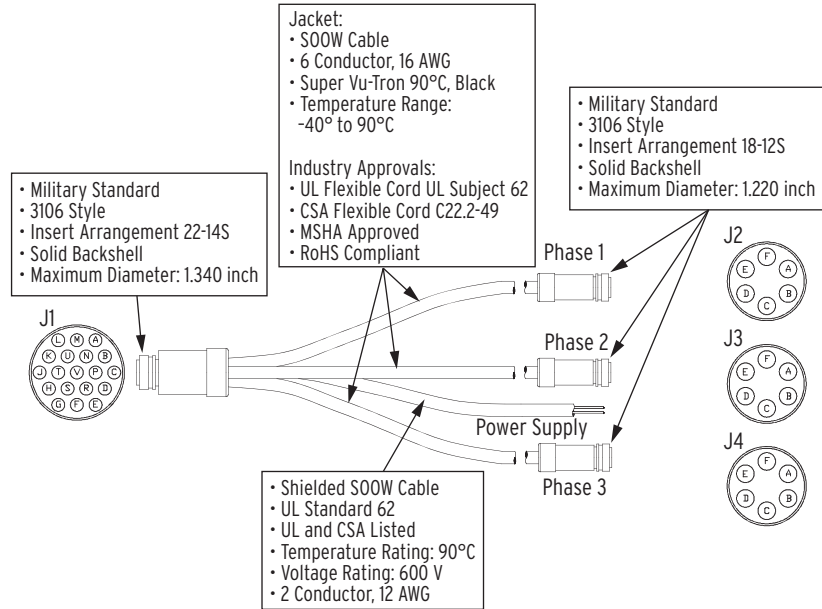

Connector Pin	Wire Color	Wire Type	Function		Connector Pin
J1-A	Black	#12 AWG 65/30 Strand	Power Supply	120 VAC	Wire Termination
J1-B	White	#12 AWG 65/30 Strand		Neutral	Wire Termination
J1-U	Red	#16 AWG 26/30 Strand	Phase 1	Common	J2-A
J1-E	White	#16 AWG 26/30 Strand		Common	J2-B
J1-D	Green	#16 AWG 26/30 Strand		Close	J2-C
J1-C	Black	#16 AWG 26/30 Strand		Open	J2-D
J1-N	Orange	#16 AWG 26/30 Strand		52b	J2-E
J1-M	Blue	#16 AWG 26/30 Strand		52a	J2-F
J1-U	Red	#16 AWG 26/30 Strand	Phase 2	Common	J3-A
J1-H	White	#16 AWG 26/30 Strand		Common	J3-B
J1-G	Green	#16 AWG 26/30 Strand		Close	J3-C
J1-F	Black	#16 AWG 26/30 Strand		Open	J3-D
J1-R	Orange	#16 AWG 26/30 Strand		52b	J3-E
J1-P	Blue	#16 AWG 26/30 Strand		52a	J3-F
J1-U	Red	#16 AWG 26/30 Strand	Phase 3	Common	J4-A
J1-L	White	#16 AWG 26/30 Strand		Common	J4-B
J1-K	Green	#16 AWG 26/30 Strand		Close	J4-C
J1-J	Black	#16 AWG 26/30 Strand		Open	J4-D
J1-T	Orange	#16 AWG 26/30 Strand		52b	J4-E
J1-S	Blue	#16 AWG 26/30 Strand		52a	J4-F

Control Cables for Full-Size Enclosures With the Combined Sensor Connector

SEL-C547

Cable SEL-C547 connects to three switches and the control power transformer (7-pin female connectors).

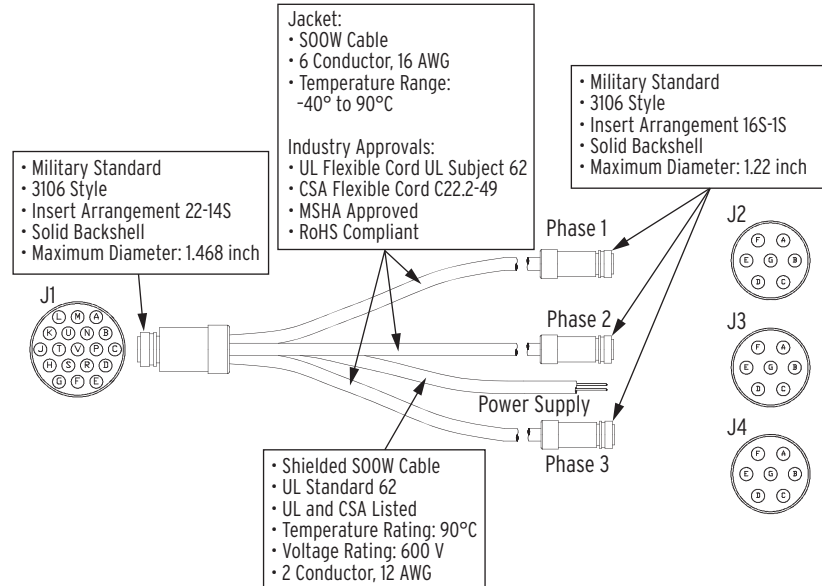

Connector Pin	Wire Color	Wire Type	Function	Connector Pin
J1-A	Black	#12 AWG 65/30 Strand	Power Supply	120 VAC
J1-B	White	#12 AWG 65/30 Strand		Neutral
J1-E	White	#16 AWG 26/30 Strand	Phase 1	Common
J1-D	Green	#16 AWG 26/30 Strand		Close
J1-C	Black	#16 AWG 26/30 Strand		Open
J1-U	Red	#16 AWG 26/30 Strand		Common
J1-N	Orange	#16 AWG 26/30 Strand		52b
J1-M	Blue	#16 AWG 26/30 Strand		52a
J1-H	White	#16 AWG 26/30 Strand	Phase 2	Common
J1-G	Green	#16 AWG 26/30 Strand		Close
J1-F	Black	#16 AWG 26/30 Strand		Open
J1-U	Red	#16 AWG 26/30 Strand		Common
J1-R	Orange	#16 AWG 26/30 Strand		52b
J1-P	Blue	#16 AWG 26/30 Strand		52a
J1-L	White	#16 AWG 26/30 Strand	Phase 3	Common
J1-K	Green	#16 AWG 26/30 Strand		Close
J1-J	Black	#16 AWG 26/30 Strand		Open
J1-U	Red	#16 AWG 26/30 Strand		Common
J1-T	Orange	#16 AWG 26/30 Strand		52b
J1-S	Blue	#16 AWG 26/30 Strand		52a

SEL-C556

Cable SEL-C556 connects to three switches and the control power transformer through a Cooper junction box (drawing CCR116K1).

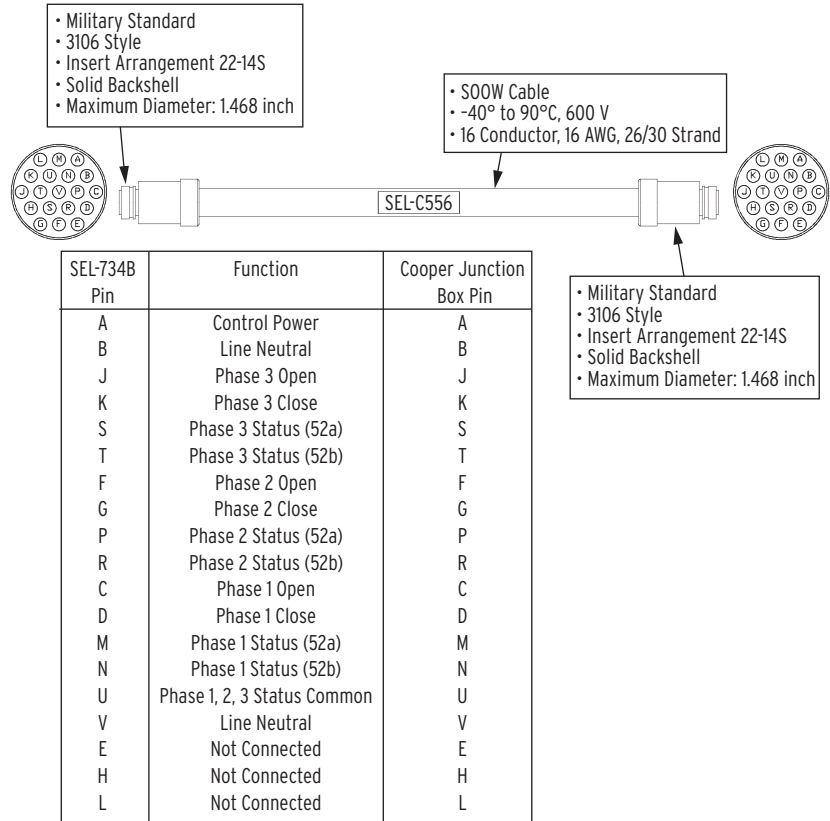

Sensor Cables for Full-Size Enclosures With the Combined Sensor Connector

R-22748/XX,YY

This cable connects to three Lindsey Manufacturing sensors and one Lindsey neutral current sensor (4-pin male connector).

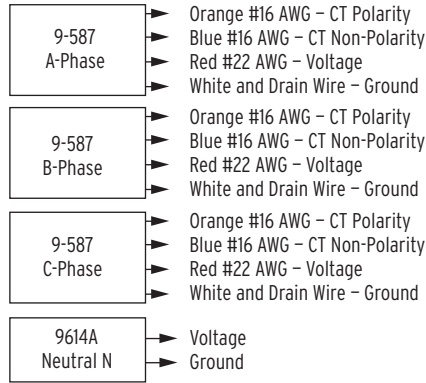

Amphenol MS3106A22-19S
 Female Amphenol Socket
 Wire Backside Connection



	Amphenol Pin	Lindsey Connection	Ref. Wires
+H	A	N/A	Black
-N	B	N/A	White
VN+	C	Neutral N+ Red (or Wht)	Red
VN-	D	Neutral N- Wht (or Blk)	Green
VA	E	A-Phase Red	Orange
VB	F	B-Phase Red	Blue
VC	G	C-Phase Red	White/Black
VG	H	A-, B-, and C-Phase White and Drain	Red/Black
IA*	J	A-Phase Orange	Green/Black
IA	K	A-Phase Blue	Orange/Black
IB*	L	B-Phase Orange	Blue/Black
IB	M	B-Phase Blue	Black/White
IC*	N	C-Phase Orange	Red/White
IC	P	C-Phase Blue	Green/White

Sensor Cables for Full-Size Enclosures With the Combined Sensor Connector

9-587/XX/R-22102

This cable connects to three Lindsey Manufacturing sensors (4-pin male connector).

SEL-C529

Cable SEL-C529 connects to three Lindsey Manufacturing sensors (4-pin male connector).

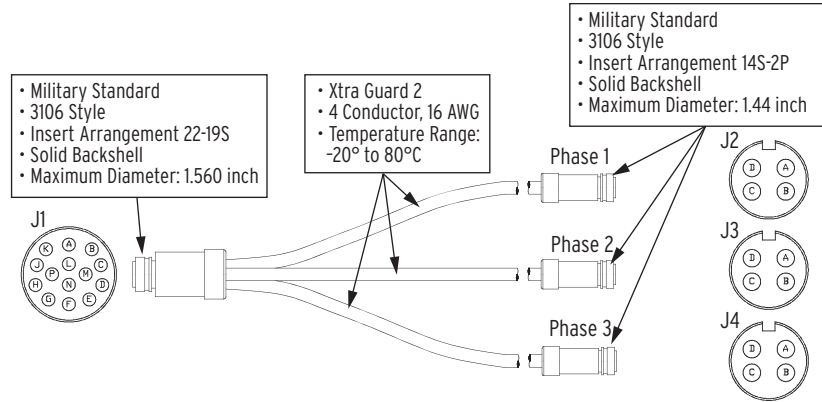

Connector Pin	Wire Color	Wire Type	Function		Connector Pin
J1-J	Red	#16 AWG 26/30 Strand	Phase 1	•IA	J2-A
J1-K	White	#16 AWG 26/30 Strand		IN	J2-B
J1-E	Green	#16 AWG 26/30 Strand		VA	J2-C
J1-H	Black	#16 AWG 26/30 Strand		VN	J2-D
J1-L	Red	#16 AWG 26/30 Strand	Phase 2	•IB	J3-A
J1-M	White	#16 AWG 26/30 Strand		IN	J3-B
J1-F	Green	#16 AWG 26/30 Strand		VB	J3-C
J1-H	Black	#16 AWG 26/30 Strand		VN	J3-D
J1-N	Red	#16 AWG 26/30 Strand	Phase 3	•IC	J4-A
J1-P	White	#16 AWG 26/30 Strand		IN	J4-B
J1-G	Green	#16 AWG 26/30 Strand		VC	J4-C
J1-H	Black	#16 AWG 26/30 Strand		VN	J4-D

Sensor Cables for Full-Size Enclosures With the Combined Sensor Connector

SEL-C536

Cable SEL-C536 connects to three Piedmont LSCV-SEL sensors (7-pin male connector).

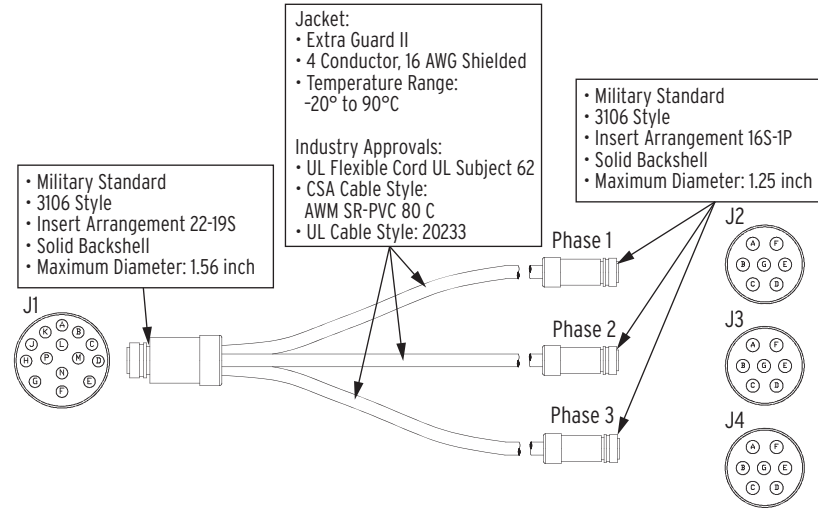

Connector Pin	Wire Color	Wire Type	Function		Connector Pin
J1-E	Red	#16 AWG 26/30 Strand	Phase 1	VA	J2-A
J1-H	Green	#16 AWG 26/30 Strand		VN	J2-F
J1-J	Black	#16 AWG 26/30 Strand		IA+	J2-D
J1-K	White	#16 AWG 26/30 Strand		IA-	J2-C
J1-A	Drain	#16 AWG 26/30 Strand		GND	J2-E
J2-G	Red	#20 AWG #20 AWG	Jumper		J2-B
			Jumper		
J1-F	Red	#16 AWG 26/30 Strand	Phase 2	VB	J3-A
J1-H	Green	#16 AWG 26/30 Strand		VN	J3-F
J1-L	Black	#16 AWG 26/30 Strand		IB+	J3-D
J1-M	White	#16 AWG 26/30 Strand		IB-	J3-C
J1-A	Drain	#16 AWG 26/30 Strand		GND	J3-E
J3-G	Red	#20 AWG #20 AWG	Jumper		J3-B
			Jumper		
J1-G	Red	#16 AWG 26/30 Strand	Phase 3	VC	J4-A
J1-H	Green	#16 AWG 26/30 Strand		VN	J4-F
J1-N	Black	#16 AWG 26/30 Strand		IC+	J4-D
J1-P	White	#16 AWG 26/30 Strand		IC-	J4-C
J1-A	Drain	#16 AWG 26/30 Strand		GND	J4-E
J4-G	Red	#20 AWG #20 AWG	Jumper		J4-B
			Jumper		

Power Supply/Neutral Sensor Cables for Full-Size Enclosures With Individual Sensor Connectors

SEL-C532

Cable SEL-C532 connects to the control power transformer and a neutral sensor.

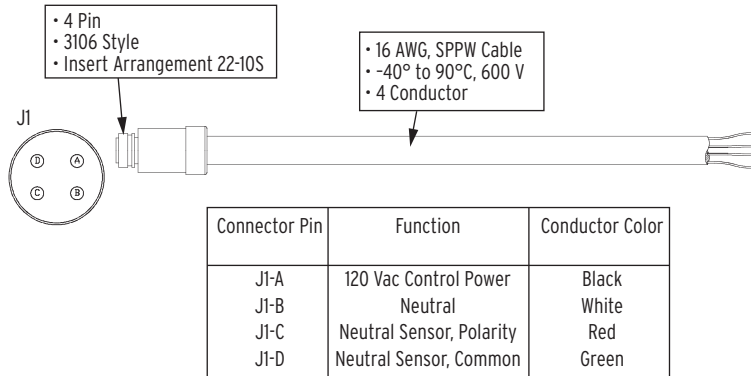

SEL-C539

Cable SEL-C539 connects to one Lindsey Manufacturing neutral sensor and the control power transformer (4-pin male connector).

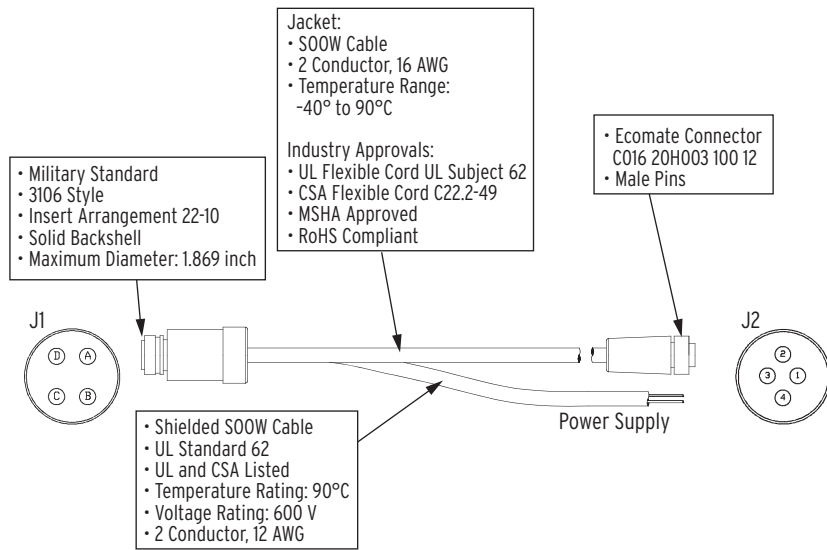

Connector Pin	Wire Color	Wire Type	Function	Connector Pin
J1-A	Black	#16 AWG 26/30 Strand	Control Power	120 VAC
J1-B	White	#16 AWG 26/30 Strand	Neutral	Neutral
J1-C	Black	#16 AWG 26/30 Strand	Neutral Sensor	J2-3
J1-D	White	#16 AWG 26/30 Strand		Common

Control Cables for Full-Size Enclosures With Individual Sensor Connectors

SEL-C537

Cable SEL-C537 connects to three switches (5-pin female connector).

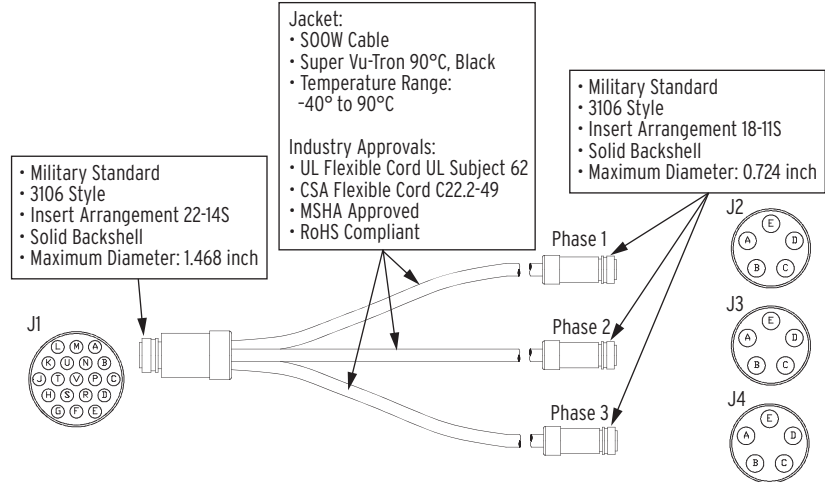

Connector Pin	Wire Color	Wire Type	Function		Connector Pin
J1-U	Red	#16 AWG 26/30 Strand	Phase 1	Common	J2-A
J1-E	White	#16 AWG 26/30 Strand		Common	J2-B
J1-D	Green	#16 AWG 26/30 Strand		Close	J2-C
J1-C	Black	#16 AWG 26/30 Strand		Open	J2-D
J1-N	Orange	#16 AWG 26/30 Strand		52b	J2-E
J1-U	Red	#16 AWG 26/30 Strand	Phase 2	Common	J3-A
J1-H	White	#16 AWG 26/30 Strand		Common	J3-B
J1-G	Green	#16 AWG 26/30 Strand		Close	J3-C
J1-F	Black	#16 AWG 26/30 Strand		Open	J3-D
J1-R	Orange	#16 AWG 26/30 Strand		52b	J3-E
J1-U	Red	#16 AWG 26/30 Strand	Phase 3	Common	J4-A
J1-L	White	#16 AWG 26/30 Strand		Common	J4-B
J1-K	Green	#16 AWG 26/30 Strand		Close	J4-C
J1-J	Black	#16 AWG 26/30 Strand		Open	J4-D
J1-T	Orange	#16 AWG 26/30 Strand		52b	J4-E

SEL-C538

Cable SEL-C538 connects to three switches (6-pin female connector).

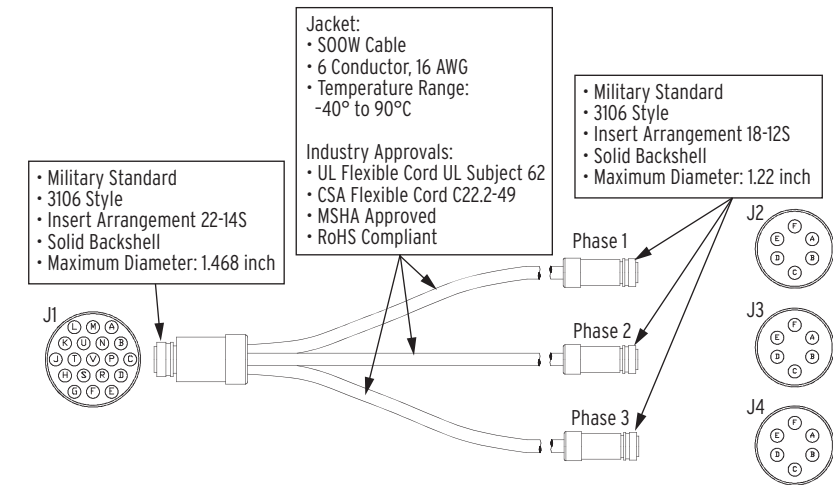

Connector Pin	Wire Color	Wire Type	Function		Connector Pin
J1-U	Red	#16 AWG 26/30 Strand	Phase 1	Common	J2-A
J1-E	White	#16 AWG 26/30 Strand		Common	J2-B
J1-D	Green	#16 AWG 26/30 Strand		Close	J2-C
J1-C	Black	#16 AWG 26/30 Strand		Open	J2-D
J1-N	Orange	#16 AWG 26/30 Strand		52b	J2-E
J1-M	Blue	#16 AWG 26/30 Strand		52a	J2-F
J1-U	Red	#16 AWG 26/30 Strand	Phase 2	Common	J3-A
J1-H	White	#16 AWG 26/30 Strand		Common	J3-B
J1-G	Green	#16 AWG 26/30 Strand		Close	J3-C
J1-F	Black	#16 AWG 26/30 Strand		Open	J3-D
J1-R	Orange	#16 AWG 26/30 Strand		52b	J3-E
J1-P	Blue	#16 AWG 26/30 Strand		52a	J3-F
J1-U	Red	#16 AWG 26/30 Strand	Phase 3	Common	J4-A
J1-L	White	#16 AWG 26/30 Strand		Common	J4-B
J1-K	Green	#16 AWG 26/30 Strand		Close	J4-C
J1-J	Black	#16 AWG 26/30 Strand		Open	J4-D
J1-T	Orange	#16 AWG 26/30 Strand		52b	J4-E
J1-S	Blue	#16 AWG 26/30 Strand		52a	J4-F

Sensor Cables for Full-Size Enclosures With Individual Sensor Connectors

SEL-C530

Cable SEL-C530 connects to one Lindsey Manufacturing sensor (4-pin female connector).

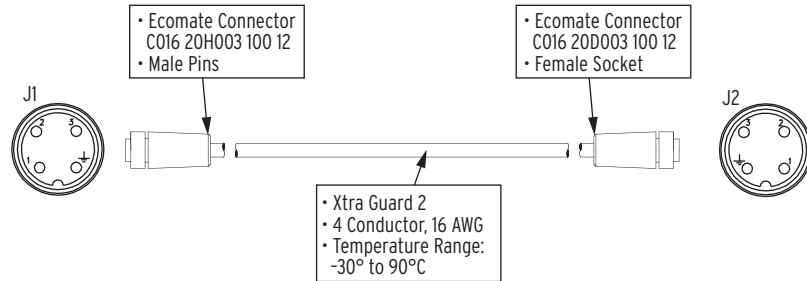

Connector Pin	Wire Color	Wire Type	Function	Connector Pin
J1-1	Black	#16 AWG 65/30 Strand	Current Sensor	Polarity
J1-2	Green	#16 AWG 65/30 Strand		Common
J1-3	Red	#16 AWG 26/30 Strand	Voltage Sensor	Polarity
J1-4	White/Drain	#16 AWG 26/30 Strand		Common

Lindsey 9-587/XX/9-582

This cable connects to one Lindsey Manufacturing sensor (4-pin male connector).

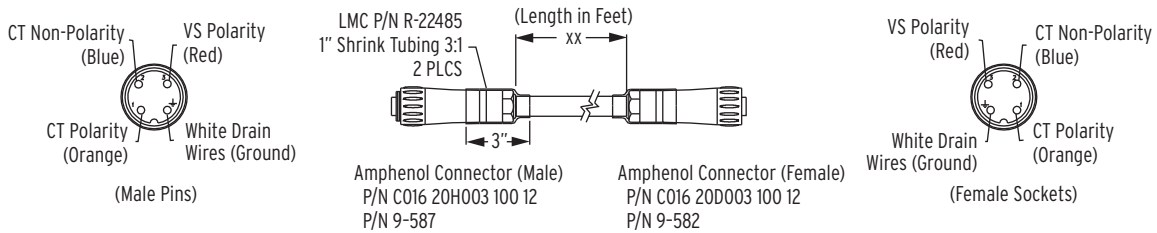

Control and Sensor Cable for Compact 7-Pin Connectorized Enclosures

SEL-C548

Cable SEL-C548 connects to one phase-current sensor, one neutral-current sensor, the control power transformer, and a three-pole switch, and is available in lengths of 30 ft (9.1 m) and 45 ft (13.7 m).

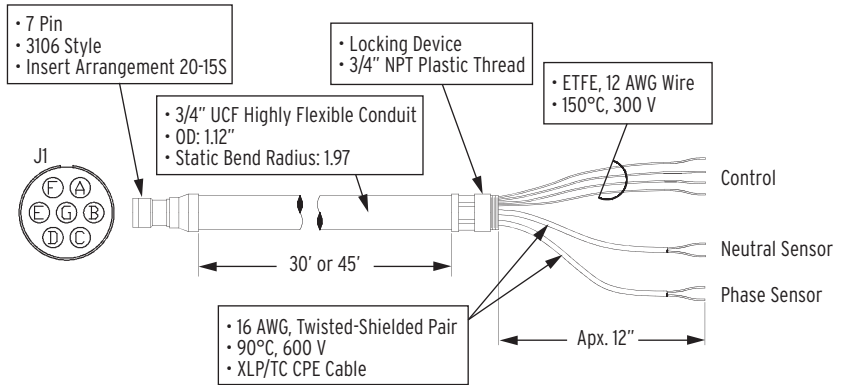

Connector Pin	Function	Conductor Color	Label	
J1-A	120 Vac	Red	120 Vac	Control
J1-B	Open	Green	Open	
J1-C	Close	Black	Close	
J1-G	System Neutral	White	Neutral	
J1-E	Neutral Sensor Polarity	Black	N.C. Pol	Neutral Sensor
J1-D	Neutral Sensor Common	White	N.C. Ret	
J1-D	Drain/Shield	Drain		
J1-F	Line Sensor Polarity	Black	L.C. Pol	Phase Sensor
J1-D	Line Sensor Common	White	L.C. Ret	
J1-D	Drain/Shield	Drain		

Appendix E

Enclosure Drawings

The following figures show a schematic diagram and a point-to-point wiring diagram of the internal wiring of the enclosures with all installed accessory options populated. Refer to the part number of your SEL-734B to determine which accessories are installed in your model.

Compact 4-Jaw Socket-Based Enclosure

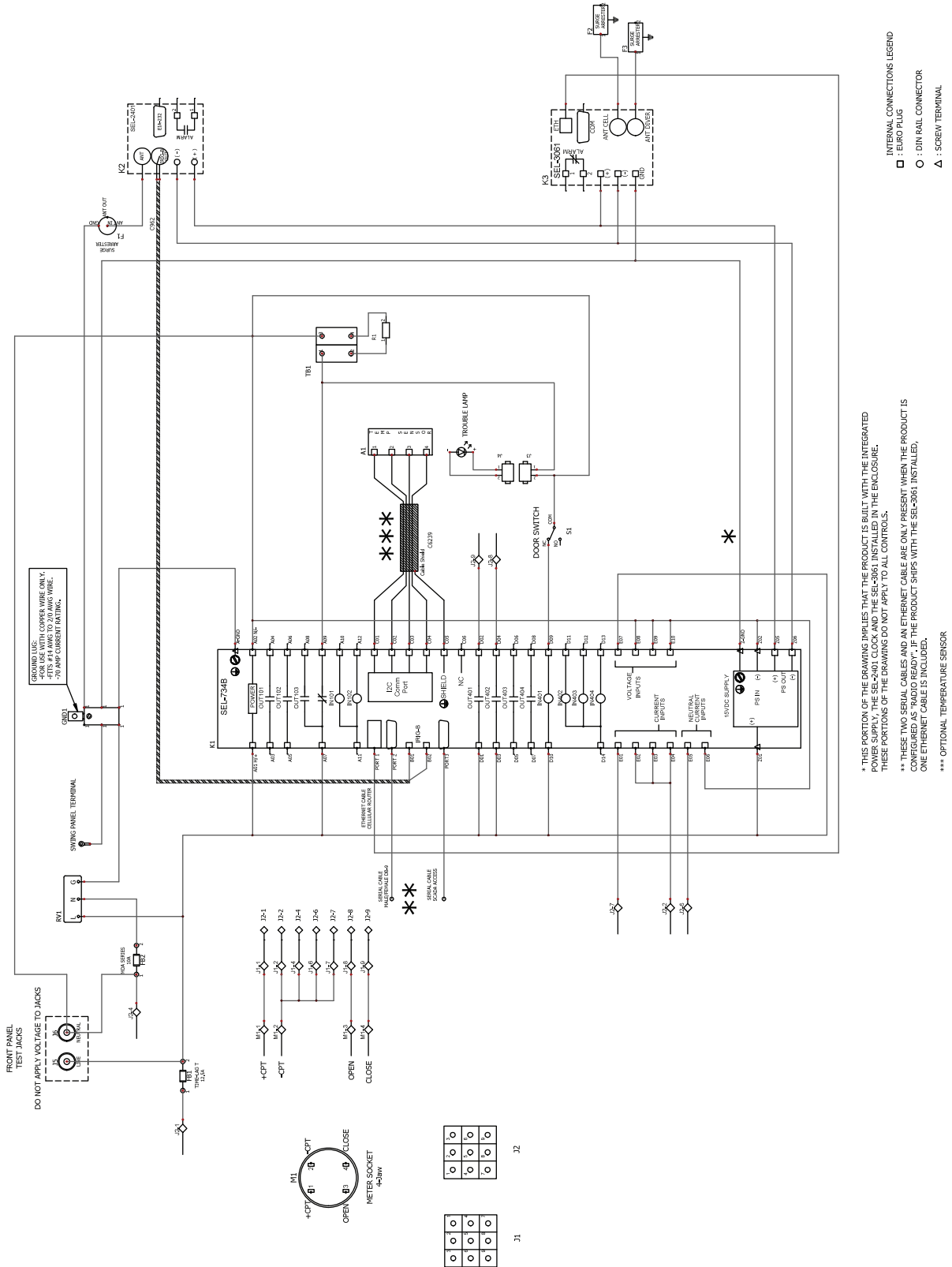

Figure E.1 Compact 4-Jaw Socket-Based Enclosure Schematic Diagram

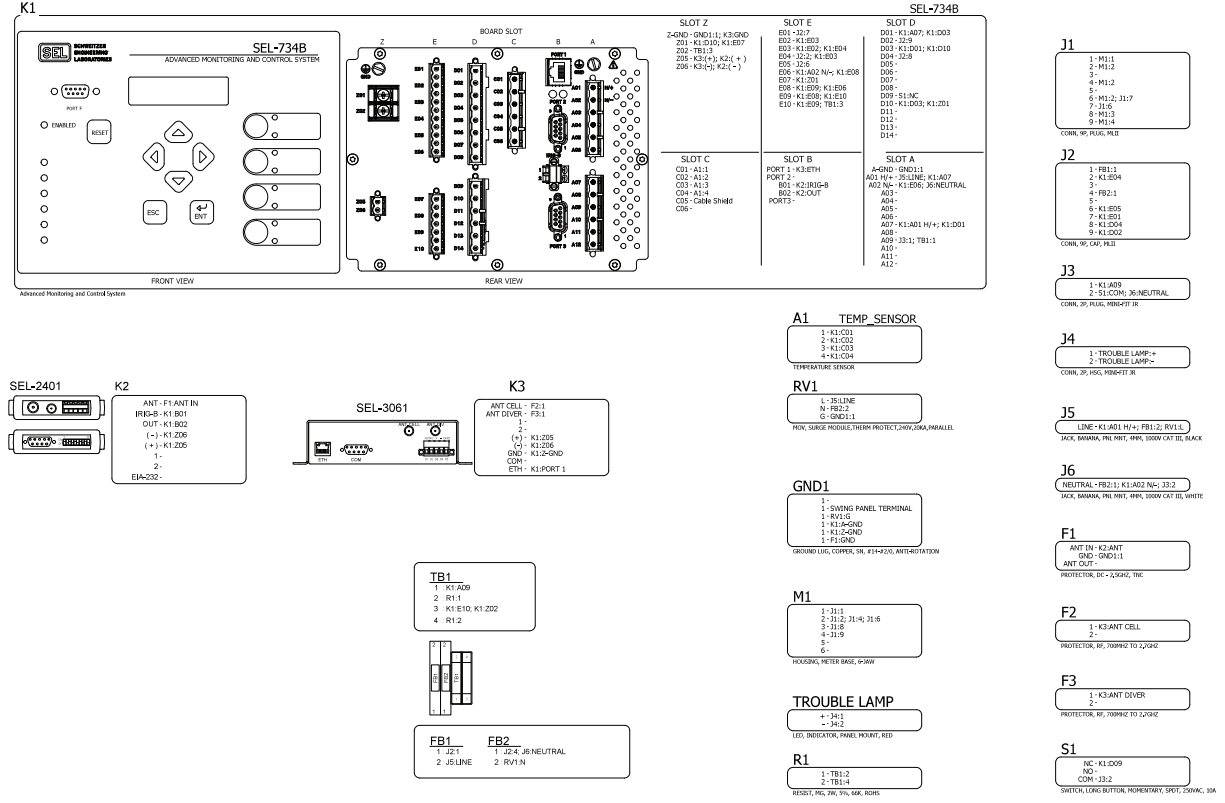

Figure E.2 Compact 4-Jaw Socket-Based Enclosure Point-to-Point Wiring Diagram

Compact 6-Jaw Option A Socket-Based Enclosure

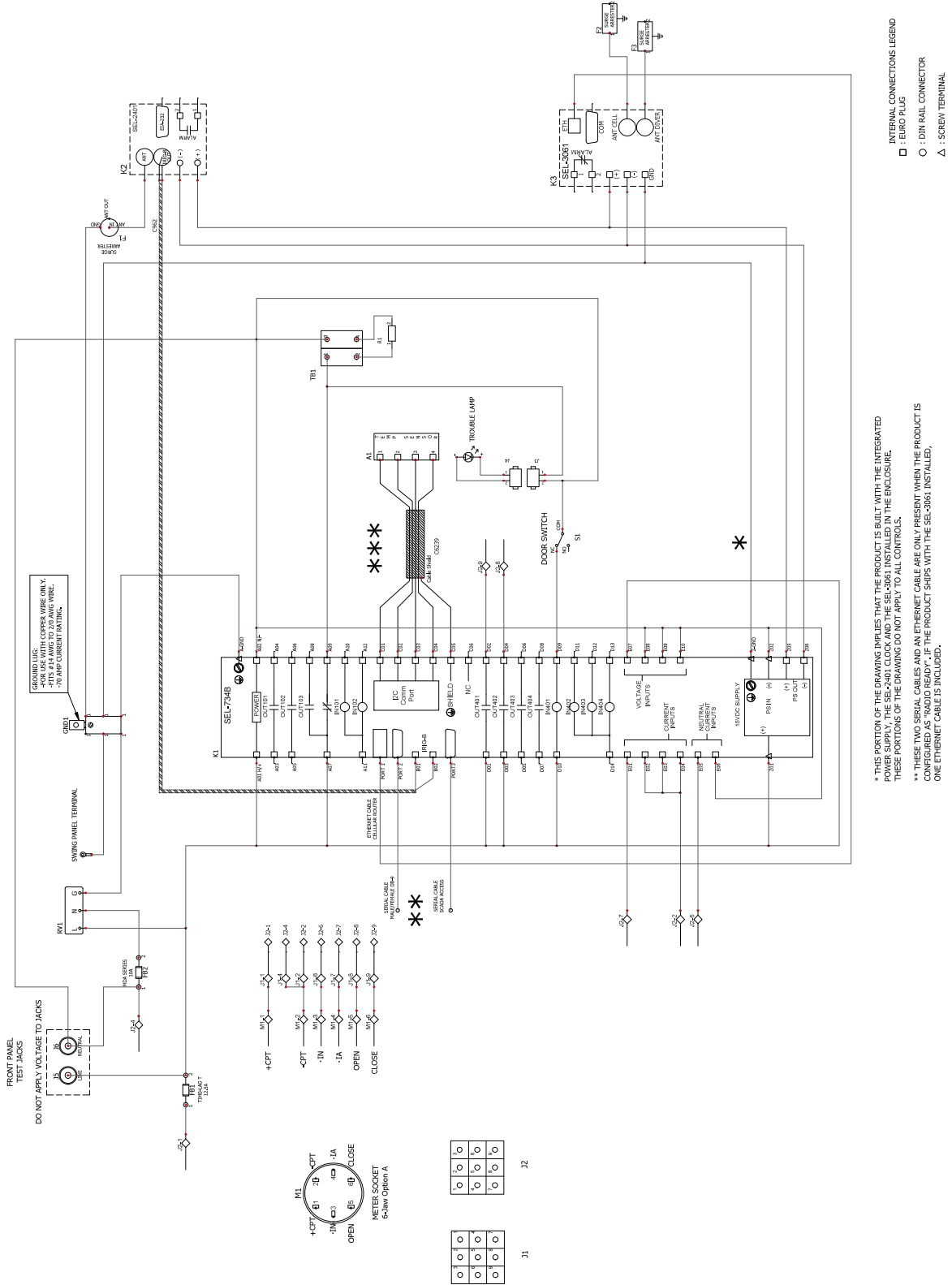

Figure E.3 Compact 6-Jaw Option A Socket-Based Enclosure Schematic Diagram

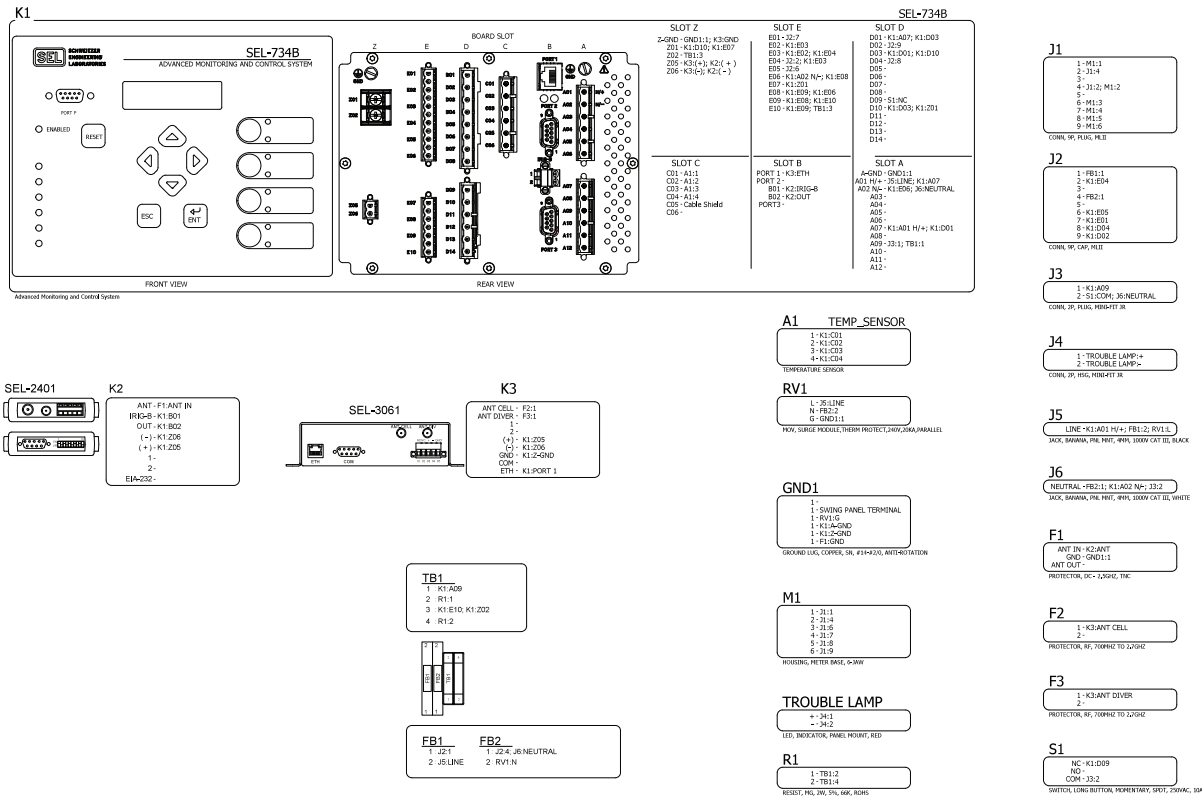
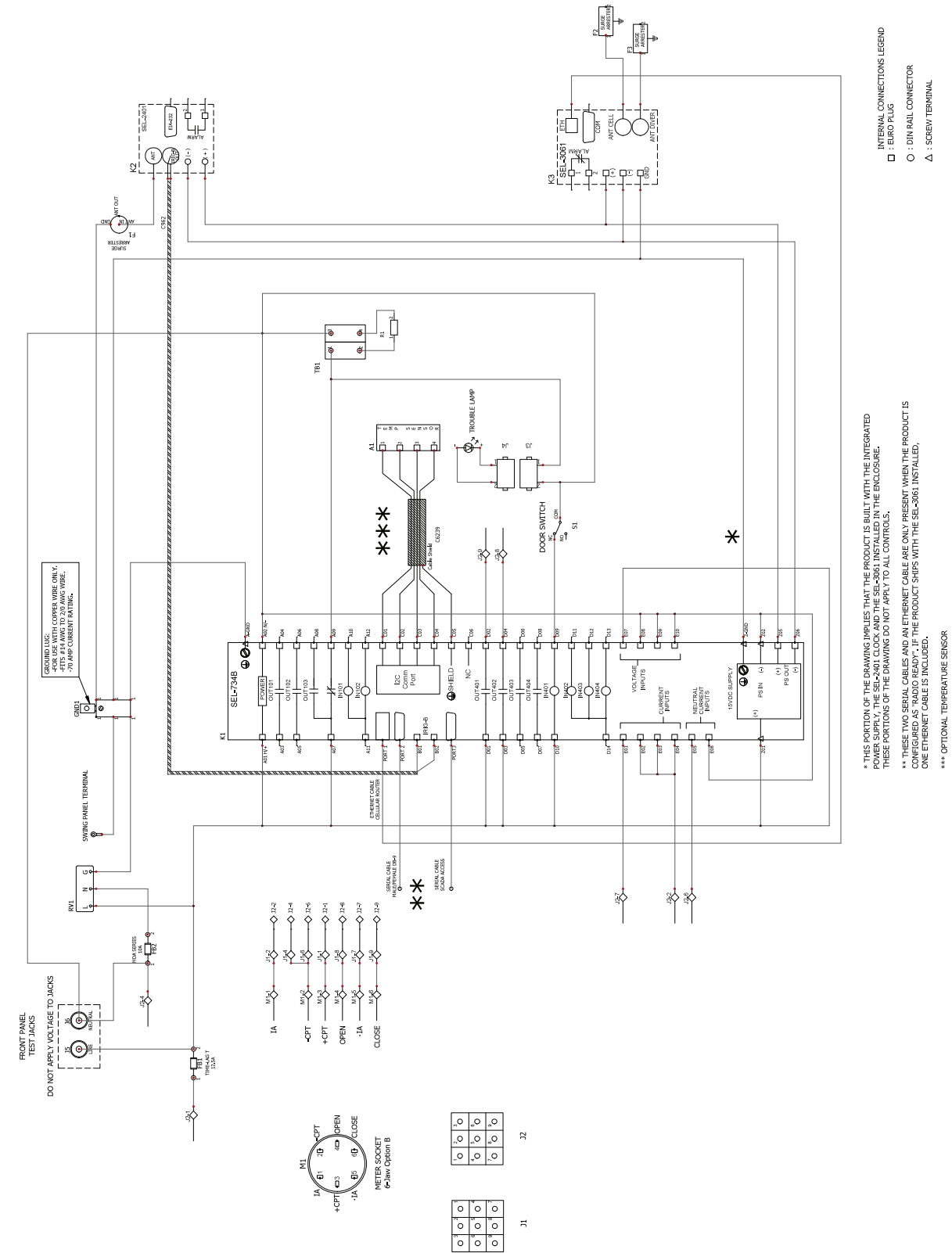

Figure E.4 Compact 6-Jaw Option A Socket-Based Enclosure Point-to-Point Wiring Diagram

Compact 6-Jaw Option B Socket-Based Enclosure



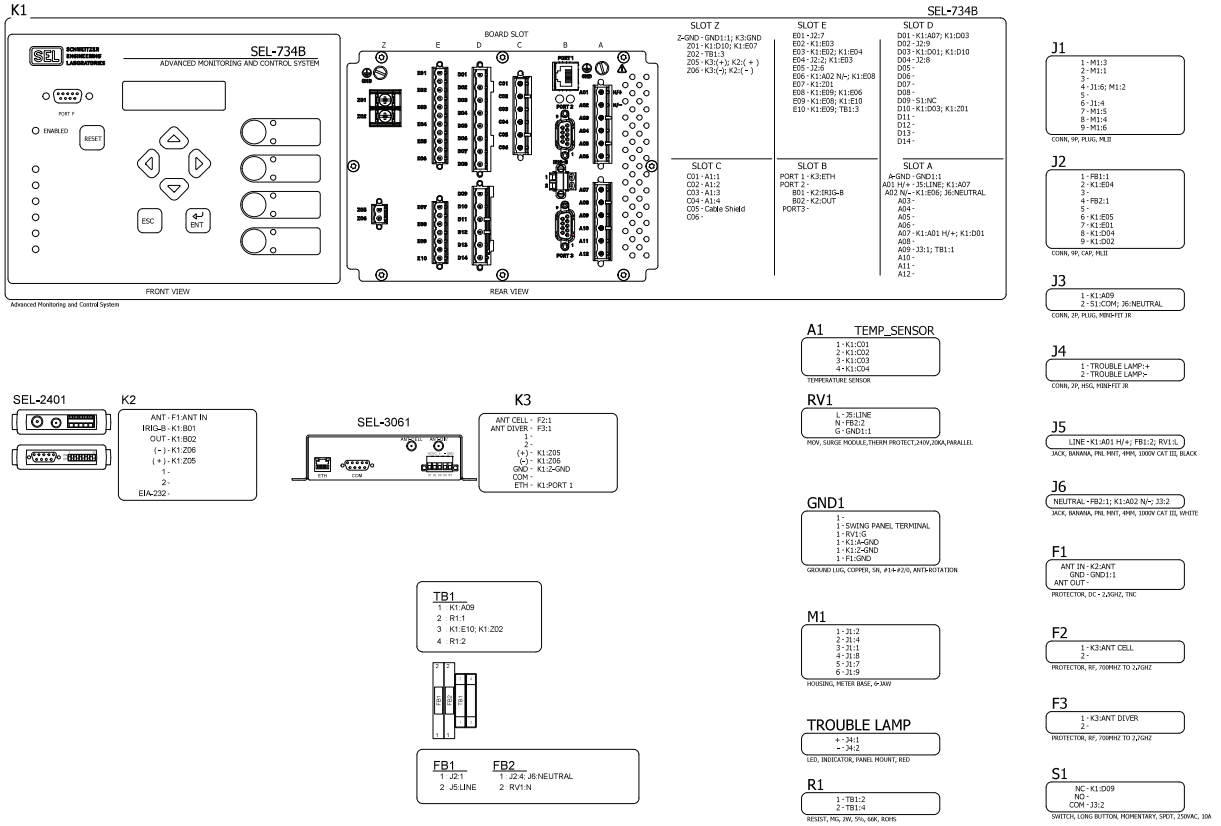

Figure E.6 Compact 6-Jaw Option B Socket-Based Enclosure Point-to-Point Wiring Diagram

Compact 7-Pin Military Connector Enclosure

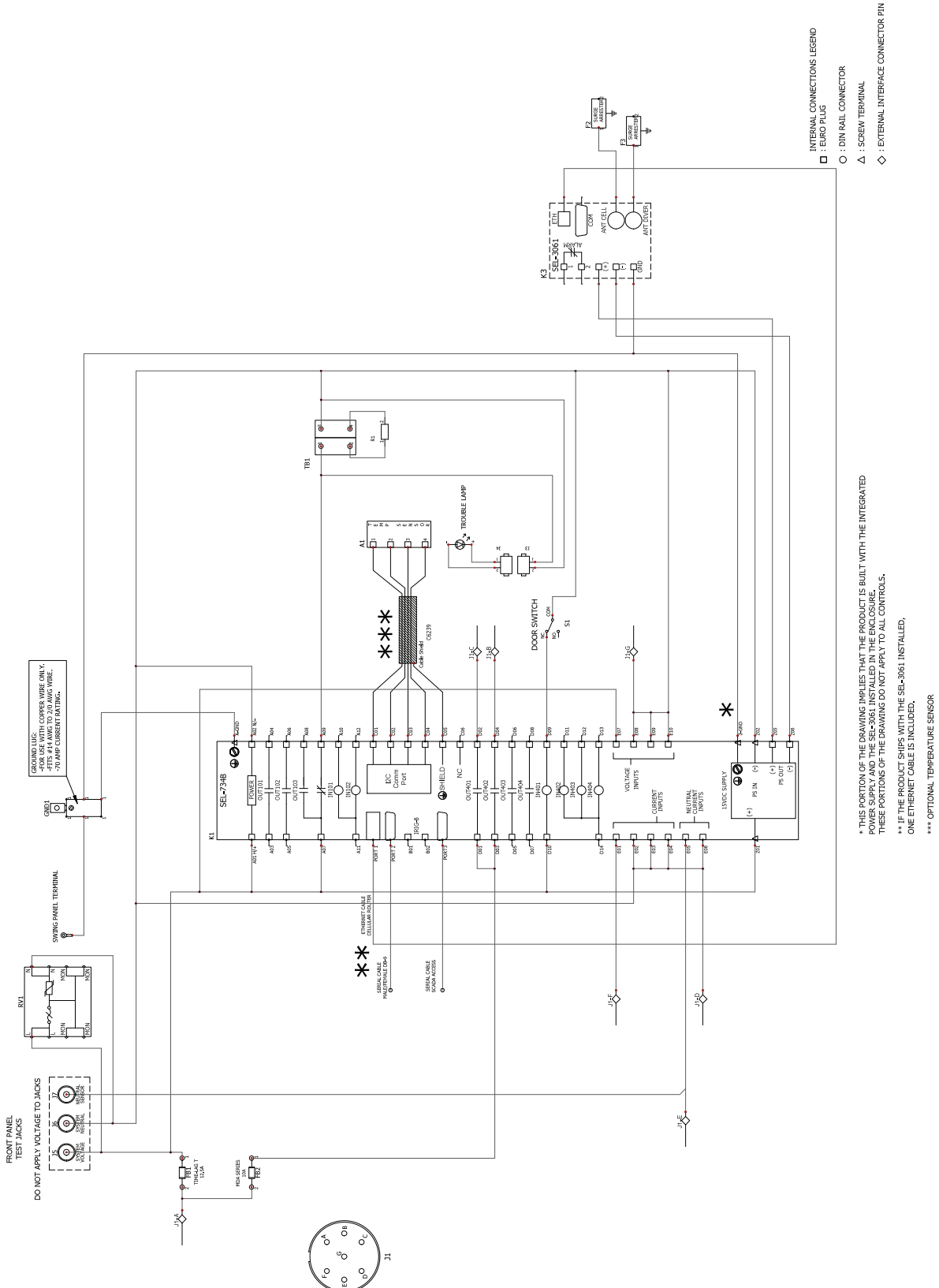

Figure E.7 Compact 7-Pin Military Connector Enclosure Schematic Diagram

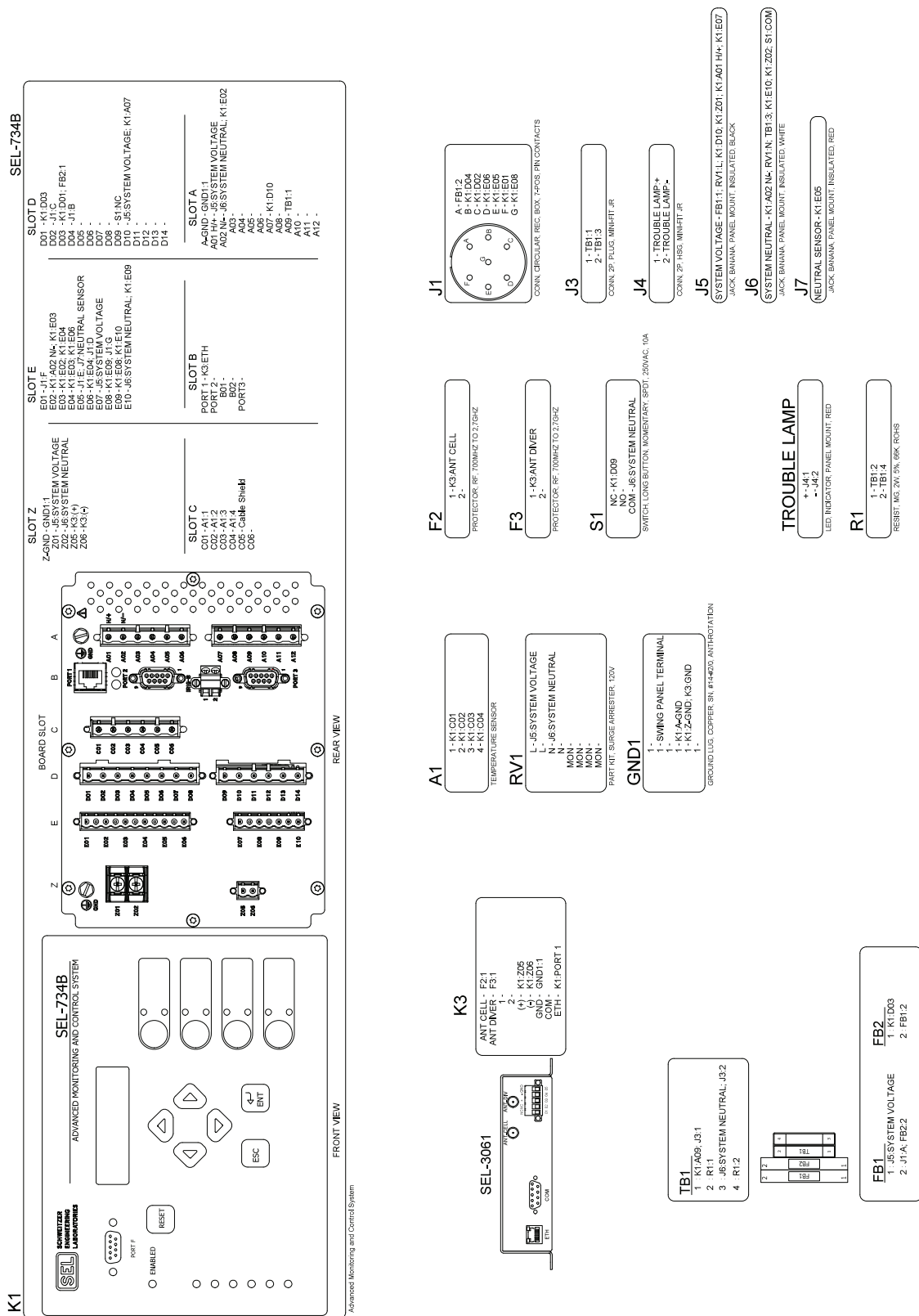

Figure E.8 Compact 7-Pin Military Connector Enclosure Point-to-Point Wiring Diagram

Compact 7-Pin Terminal Block Connector Enclosure

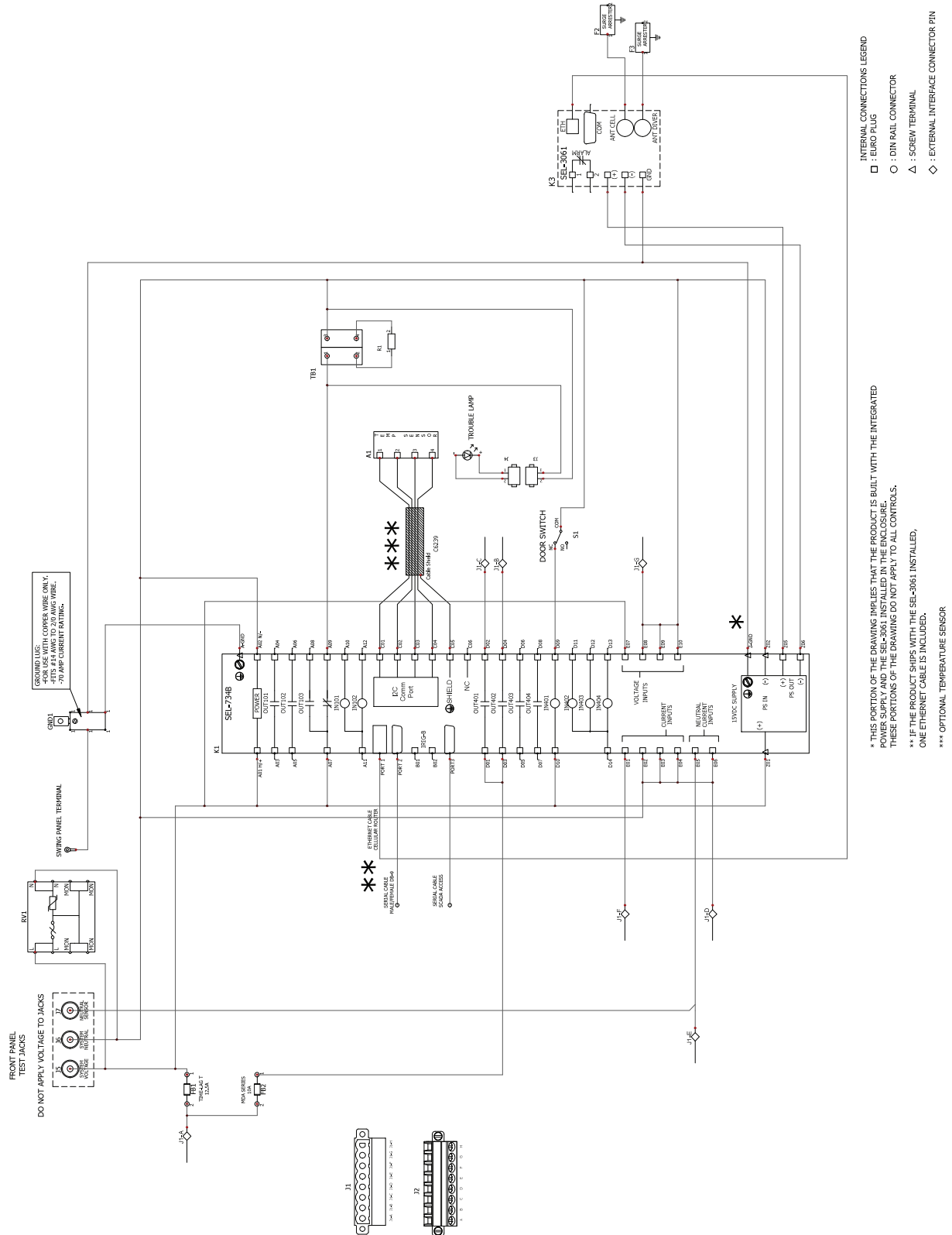

Figure E.9 Compact 7-Pin Terminal Block Connector Enclosure Schematic Diagram

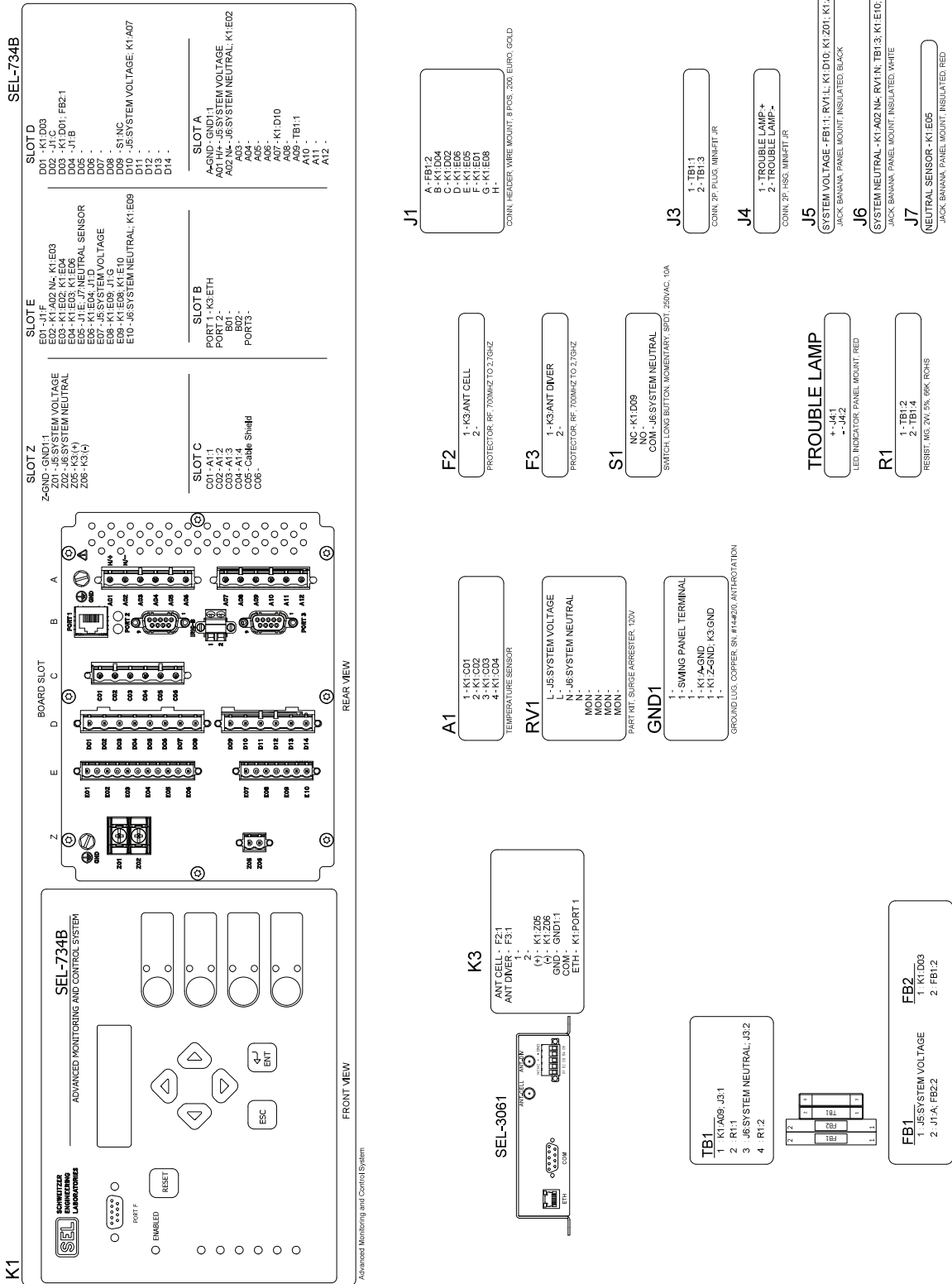

Figure E.10 Compact 7-Pin Terminal Block Connector Enclosure Point-to-Point Wiring Diagram

Full-Size Combined Sensor Connector Enclosure

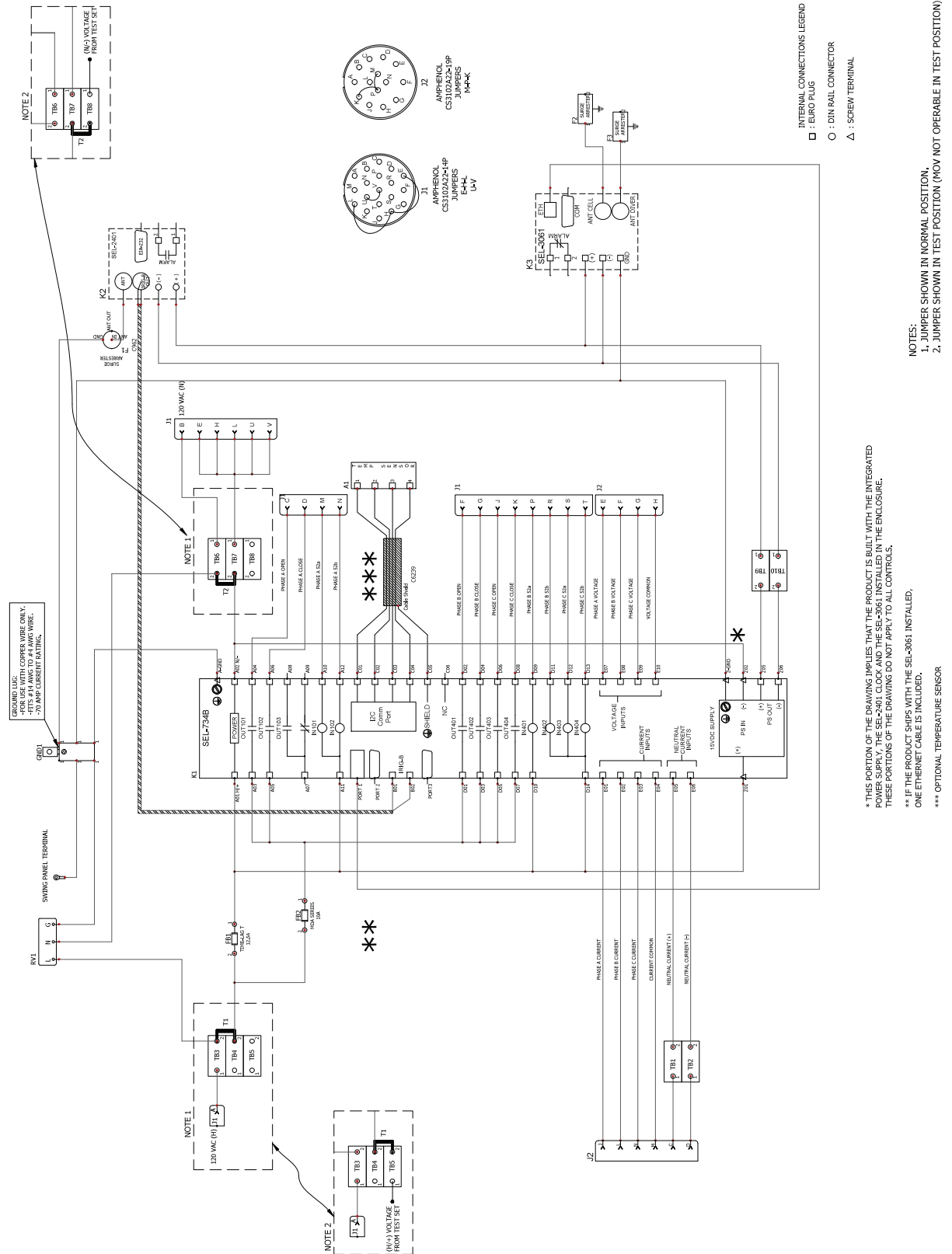

Figure E.11 Full-Size Combined Sensor Connector Enclosure Schematic Diagram

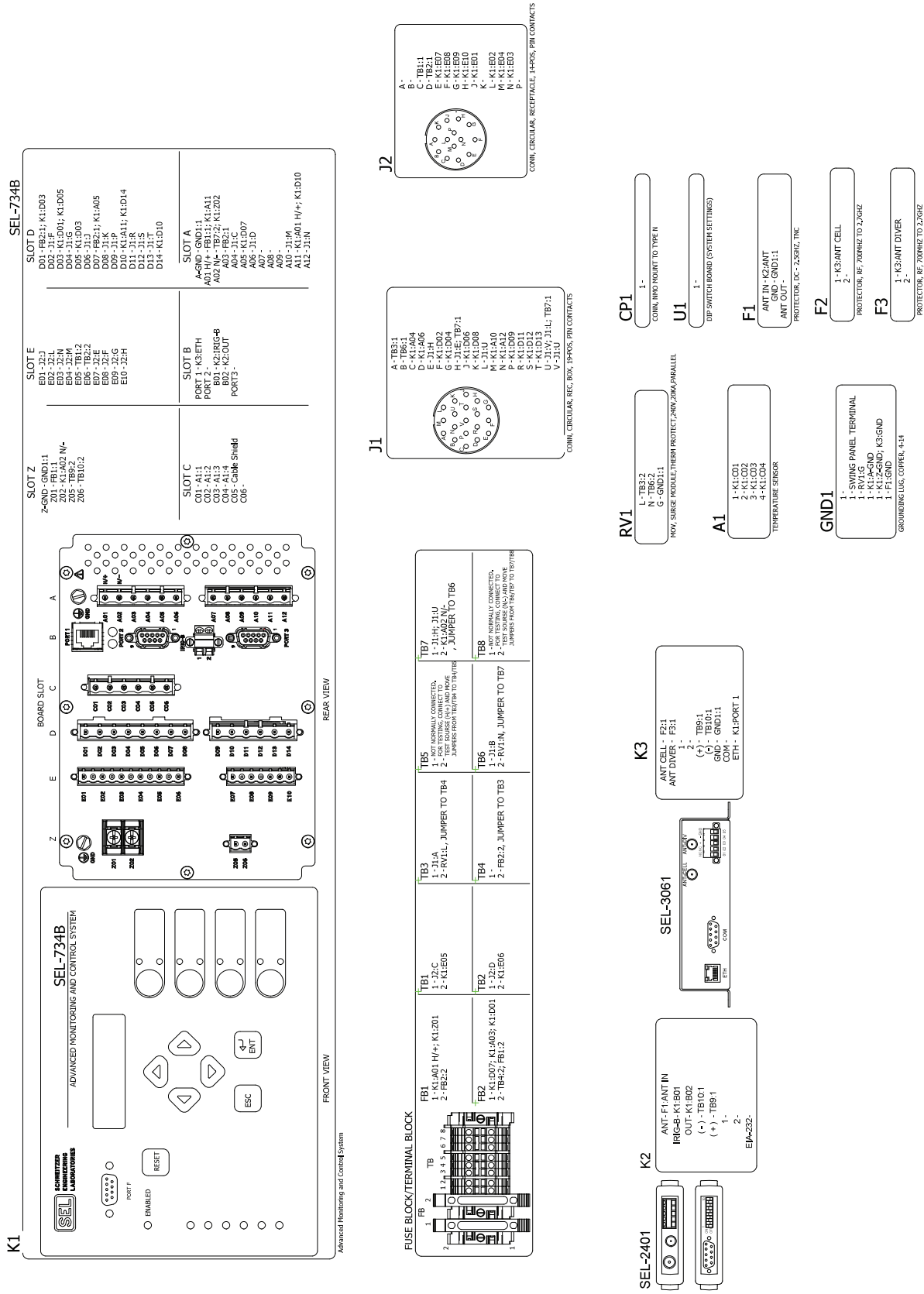

Figure E.12 Full-Size Combined Sensor Connector Enclosure Point-to-Point Wiring Diagram

Full-Size Individual Sensor Connector Enclosure

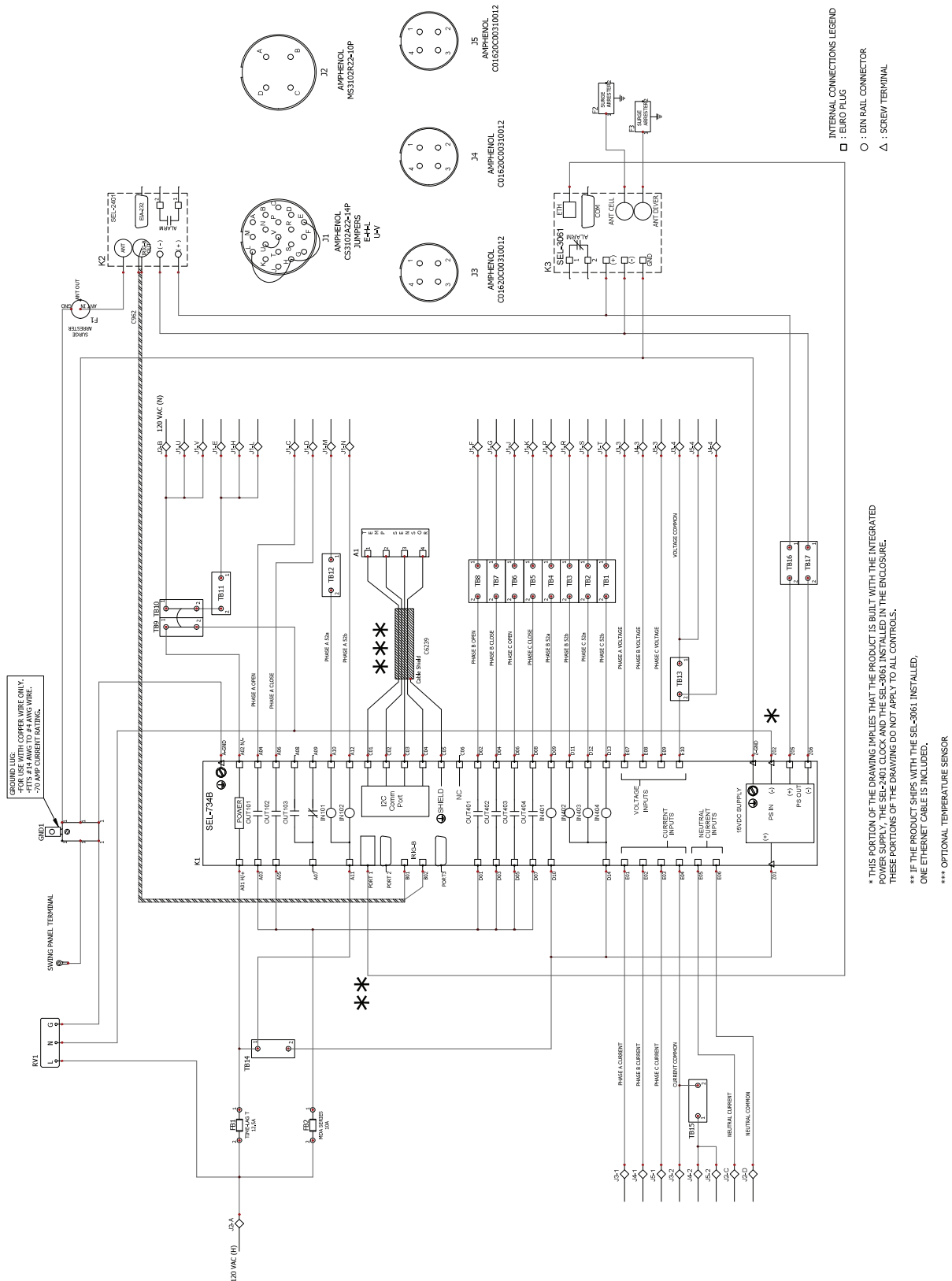

Figure E.13 Full-Size Individual Sensor Connector Enclosure Schematic Diagram

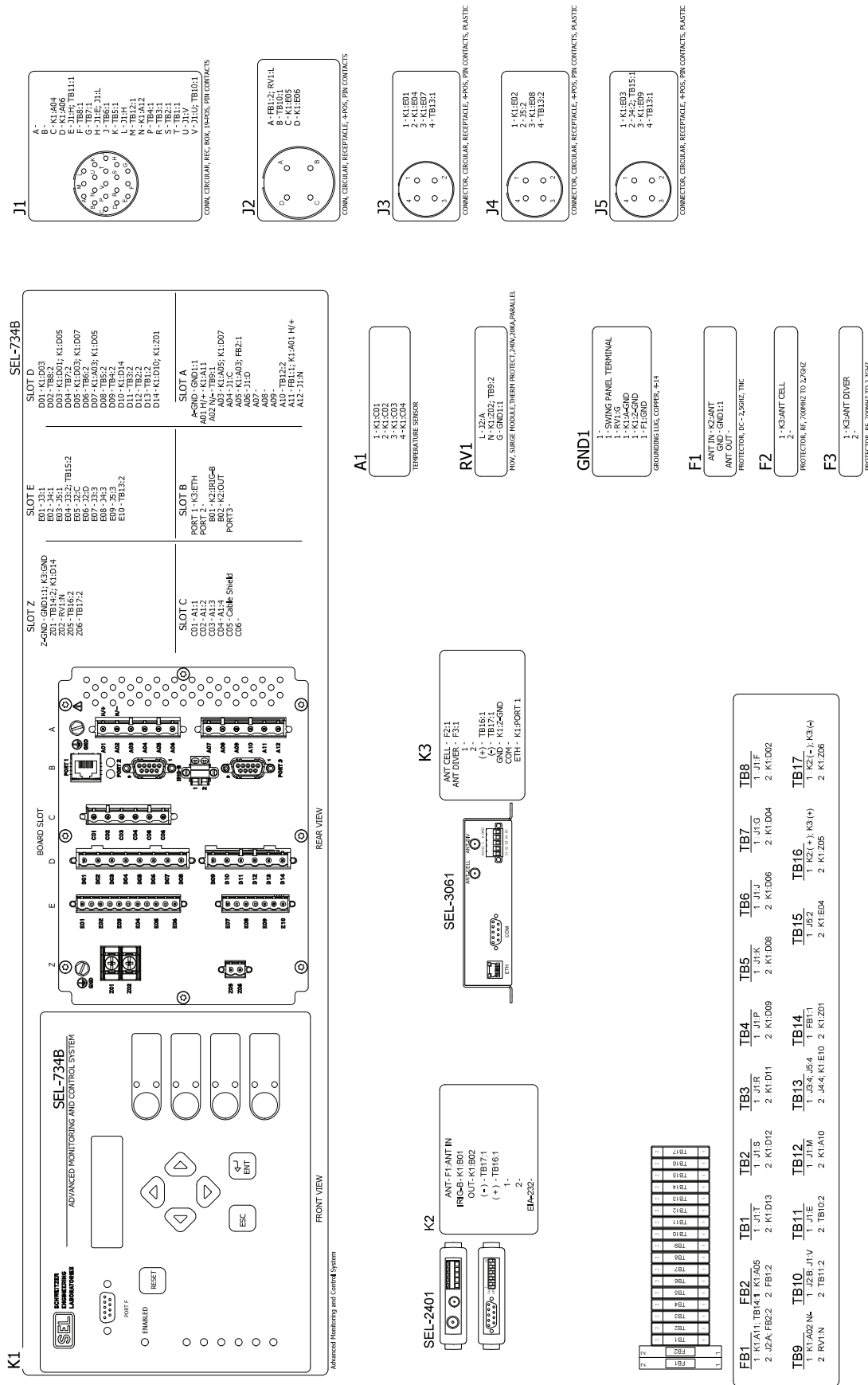

Figure E.14 Full-Size Individual Sensor Connector Enclosure Point-to-Point Wiring Diagram

This page intentionally left blank

Appendix F

Accessories

Compact Enclosure Accessories

This section describes the cables and accessories available with the SEL-734B compact enclosures.

Mounting

Part Number	Description
915900302	Meter locking ring. Compatible with the 4-jaw and 6-jaw socket-based enclosure styles.
915900298	Pole-mounting bracket. Compatible with the 7-pin enclosure (Connectorized or terminal block) style (see <i>Figure 3.3</i>).

Control and Measurement

Part Number	Description
SEL-C548	Control and sensor cable. Compatible with the 7-pin connectorized enclosure style. Connects to the following equipment: <ul style="list-style-type: none">▶ Control power transformer▶ One trip/close switch circuit▶ One phase current sensor▶ One neutral current sensor

Security Sleeves

The security sleeve for the connectorized enclosure style shrouds the cable connection to prevent vandalism. The sleeve is made from stainless steel.

Part Number	Description
9250011	Security sleeve for the 7-pin connectorized enclosure style.

Full-Size Enclosure Accessories

This section describes the cables and accessories available with the SEL-734B Full-Size Enclosures.

Mounting

A factory-installed pole-mounting bracket is an ordering option for the full-size enclosure (see *Figure 3.2*). It is not available as a field-installed accessory.

Part Number	Description
915900448	Two stainless steel pole-mounting straps, 9-1/2" to 12-1/4" in diameter. Compatible with factory-installed mounting bracket.

Control Cables

The following cables are three-phase control cables that connect to three capacitor bank switches. Each cable also connect to a 120 Vac control power transformer (CPT).

Part Number	Description
SEL-C543	Cable with 52b feedback. Compatible with 5-pin capacitor bank switches.
SEL-C544	Cable with 52a/b feedback. Compatible with 6-pin capacitor bank switches.
SEL-C547	Cable with 52a/b feedback. Compatible with 7-pin capacitor bank switches.

The following control cable connects the SEL-734B enclosure to a Cooper CCR116K1 junction box.

Part Number	Description
SEL-C556	Cable with 52a/b feedback. Compatible with a Cooper CCR116K1 junction box. The SEL-C526 cable can be used to connect the junction box to an individual switch.

Combined Sensor Connector Option

The following accessories are compatible with Full-Size Enclosures using the combined sensor connector.

Sensor Cables

The following sensor cables connect from the enclosure to three voltage/current combination sensors.

Part Number	Description
SEL-C529	Compatible with Lindsey combination sensors.
SEL-C536	Compatible with Piedmont LSCV-SEL model sensors.
Lindsey 9-587/XX/R-22102 ^a	Compatible with Lindsey combination sensors.
Lindsey R-22748/XX,YY ^a	Compatible with Lindsey combination sensors and one Lindsey neutral current sensor.

^a Orderable through Lindsey.

Commissioning and Testing Cables

Part Number	Description
SEL-C545 (Control)	This cable is used to simulate capacitor bank switches. A 19-pin circular connector connects to the enclosure and insulated banana plugs connect to the test source.
SEL-C546 (Sensor)	This cable is used to simulate voltage and current sensor signals. A 14-pin circular connector connects to the enclosure and insulated banana plugs connect to the test source.

Security Sleeves

Security sleeves for enclosures with a combined sensor connector shroud a single cable connection to prevent vandalism. The sleeves are made from stainless steel. Separate security sleeves are required for each cable (i.e., one sleeve is required for the control cable, and one sleeve is required for the sensor cable.)

Part Number	Compatible Cables
9250011	SEL-C556, SEL-C529, SEL-C536, SEL-C548
915900311	SEL-C543, SEL-C544, SEL-C547

Individual Sensor Connector Option

The following accessories are compatible with Full-Size Enclosures using individual sensor connectors.

Control Cables

The following control cables connect to three capacitor bank switches. The control power transformer is connected to the enclosure via a different cable.

Part Number	Description
SEL-C531	5-Pin switch cable. Compatible with Joslyn VersaVac, ABB PS, and Cooper VCS switches.
SEL-C537	5-Pin switch cable with 52b feedback. Compatible with Joslyn VersaVac, ABB PS, and Cooper VCS switches.
SEL-C538	6-Pin switch cable with 52a/b feedback. Compatible with Joslyn VersaVac switches, Cooper NR and NRV oil switches, and Cooper VCS vacuum switches.

Sensor Cables

Sensor cables for this enclosure style connect to a single voltage/current combination sensor. Connect three primary sensors to the enclosure for three-phase monitoring.

Part Number	Description
SEL-C530	Sensor cable for one Lindsey sensor with an ITT Cannon plug.
SEL-C530S	Sensor connector shorting plug. Connect to unused sensor connectors on the cabinet. The plug shorts the connector pins to prevent unwanted noise on the terminals.
Lindsey 9-587/XX/9-582 ^a	Cable for one Lindsey sensor. Alternative to SEL-C530.

^a Orderable through Lindsey.

Power Supply/Neutral Sensor Cables

The following cables connect to a neutral current sensor and a 120 Vac CPT.

Part Number	Description
SEL-C532	Control power and neutral sensor cable. Wires for the neutral sensor connect to a terminal in the field.
SEL-C539	Control power and Lindsey neutral sensor cable.

Security Sleeves

Security sleeves for the individual sensor connector enclosure style shroud all cable connection points to prevent vandalism. The sleeves are made from stainless steel. One security sleeve is required for the enclosure.

Part Number	Security Sleeve Cable Compatibility
915900224	SEL-C530, SEL-C530S, SEL-C531, SEL-C532, SEL-C539, Lindsey 9-587/XX/9-582
915900304	SEL-C530, SEL-C530S, SEL-C531, SEL-C532, SEL-C537, SEL-C538, SEL-C539, Lindsey 9-587/XX/9-582



SCHWEITZER ENGINEERING LABORATORIES, INC.

2350 NE Hopkins Court • Pullman, WA 99163-5603 U.S.A.

Phone: +1.509.332.1890 • Fax: +1.509.332.7990

selinc.com • info@selinc.com