



Using the SEL-2488 to Provide IEEE 1588 Version 2 Grandmaster Functionality in a Redundant Network Topology

Larry Thoma

INTRODUCTION

IEEE 1588 Version 2 is a standard for delivering precise time through Ethernet networks. The nature of Precision Time Protocol (PTP), used in accordance with the standard and with standard-compliant devices, allows time synchronization over Ethernet networks with submicrosecond accuracy.

Ethernet networks can be designed with redundant paths so that if a device fails on the network backbone, the alternate paths take over and critical communications continue to flow. PTP master clocks can leverage the redundant paths and continue to provide time to slave clocks.

PROBLEM

Most grandmaster devices (except boundary clocks) only have one network connection, and if the network device (e.g., a transparent clock [TC]) that it is connected to fails, then the grandmaster is out of commission as well. In this manner, PTP communications are similar to other timing solutions because there are many single points of failure that can cause a timing solution to fail.

While a redundant network topology can address many of the possible failure points, it still does not address the single connection from the grandmaster clock to the network.

SEL SOLUTION

The SEL-2488 Satellite-Synchronized Network Clock with the PTP option is designed with multiple independent Ethernet interfaces that can be leveraged to address a single point of failure of the grandmaster clock connection to the network backbone through the transparent clock. Each of its main Ethernet interfaces is a master clock with grandmaster capability and has the same time-stamp accuracy on each port.

IEEE C37.238 2011 requires the use of Ethernet Layer 2 transport for PTP communications. This transport uses an Ethernet media access control (MAC) address instead of an IP address for device and port identity. The SEL-2488 sets a unique MAC address for each Ethernet interface on the device, which prevents the contention of having multiple interfaces from the SEL-2488 connected to the same network without performing special network configurations. The best master clock algorithm evaluates the master clock on each connection when determining the grandmaster clock.

The solution is to connect two or more of the interfaces on the SEL-2488 to different transparent clocks in the redundant network topology. If one transparent clock fails and the selected grandmaster port is not reachable on the SEL-2488, then the slave devices selects the master

clock on another interface on the SEL-2488 as the grandmaster. The PTP traffic routes through the reconfigured network architecture. Each of the SEL-2488 interfaces connected to the redundant network is configured with similar PTP master parameters (domain, priority, and so on). This leaves the clock identity, which is based on the MAC address, to be the tie breaker for which interface is selected as the grandmaster. When the original interface is restored and visible, the best master clock algorithm recognizes the restored interface as an available master with no intervention.

To guard against the failure of the SEL-2488, a second SEL-2488 can be connected in the redundant network topology, as shown in Figure 1. If the active SEL-2488 grandmaster fails, the best master clock algorithm selects the redundant SEL-2488 as the grandmaster with no reconfiguration of the solution.

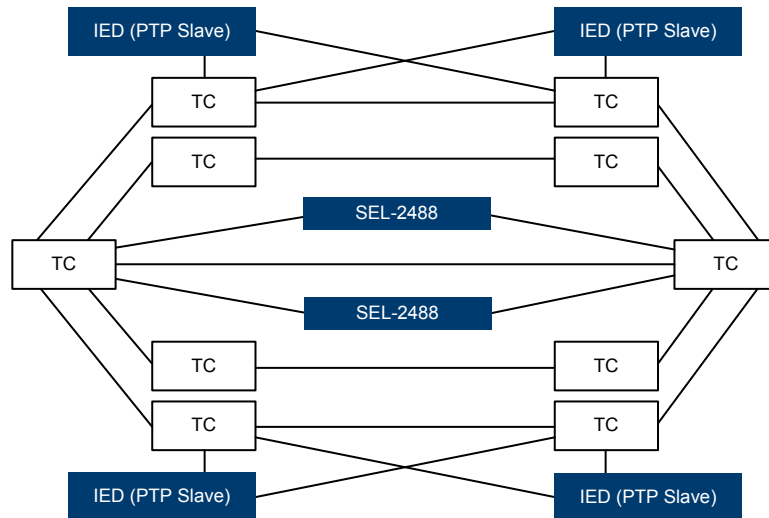

Figure 1 Redundant Ladder Network Topology

Figure 1 shows typical redundant interconnect topology. Rapid Spanning Tree Protocol (RSTP) is enabled to manage the switch network. In this network, each SEL-2488 is connected to two transparent clocks, providing failure protection for multiple scenarios. Optionally, the slave clocks (intelligent electronic devices [IEDs]) are shown with multiple connections to the network for the same reason.

In the event of a network reconfiguration due to a device failure, the time it takes to reconfigure the network is typically a few milliseconds. PTP only transmits timing messages at a one-per-second rate per IEEE C37.238 requirements. Therefore, a single message may be lost, but there will be no effect on the PTP timing solution.

Under normal operation, the PTP traffic routes as illustrated in Figure 2.

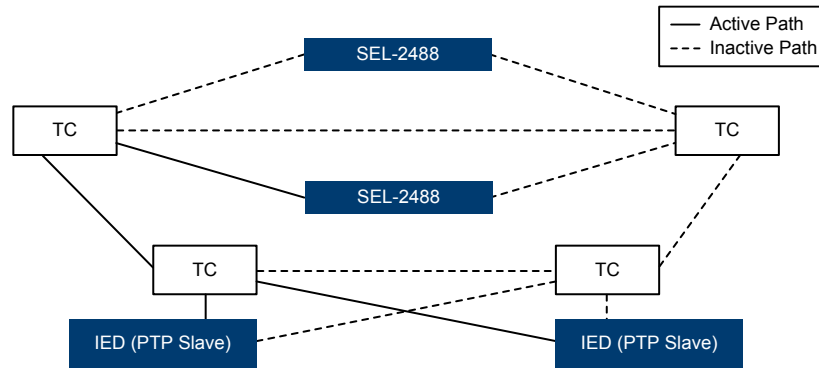

Figure 2 Normal Operation

Figure 3, Figure 4, Figure 5, and Figure 6 show various failures and the automatic reconfiguration (network and best master clock algorithm) that occurs to reroute traffic and to maintain PTP master-slave communications.

Figure 3 demonstrates the reconfiguration of the network and how PTP signals are maintained during a root switch interruption.

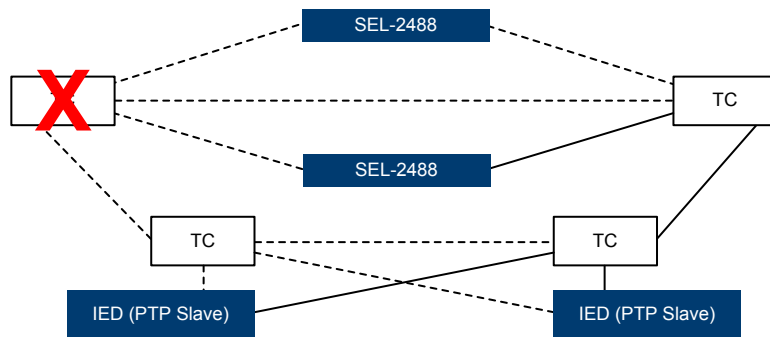

Figure 3 Root Switch Failure—Use Alternative Path

Figure 4 demonstrates the reconfiguration of the network and how PTP signals are maintained during a ladder switch interruption.

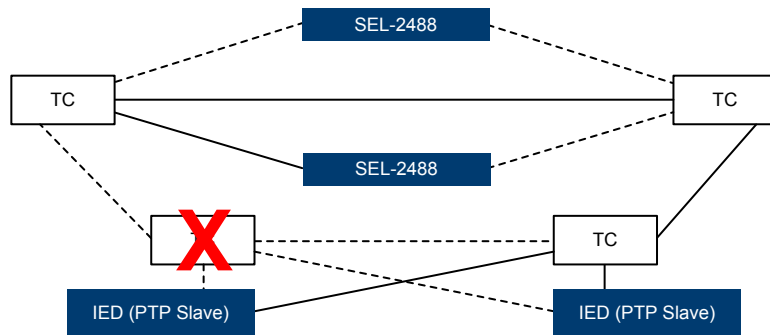

Figure 4 Ladder Switch Failure—Use Redundant Path

Figure 5 shows that the PTP slave device continues to operate and receive time through the alternate port during a primary port interruption.

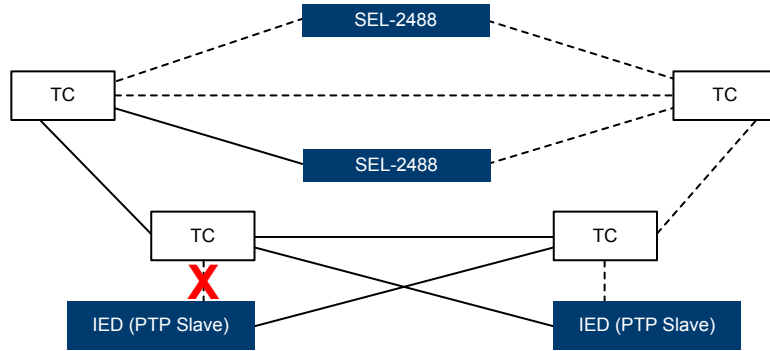

Figure 5 IED Port Failure—Use Alternative Port

Figure 6 shows that the PTP timing continues during a primary clock failure. The redundant clock provides PTP time signals when it recognizes that the primary clock is no longer sending signals to the network (within 2 to 3 seconds of the failure).

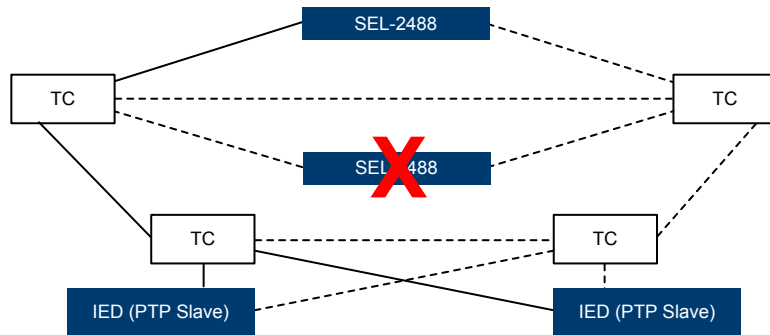

Figure 6 Clock Failure—Use Redundant Clock

CONCLUSION

With four main Ethernet connections to the device, the SEL-2488 provides a solution to many cases of a single point of failure on the network. A single SEL-2488, when connected in the manner described in this application note, will continue to provide PTP time to the end devices, even with a primary network switch failure. Adding a second SEL-2488 provides redundancy for the grandmaster clock, making the PTP timing backbone fully redundant.