



# RTAC SEL-3555 Real-Time Automation Controller



The SEL-3555 Real-Time Automation Controller (RTAC) is a powerful automation platform that combines the best features of the high-performance x86-64 architecture, embedded microcomputer, embedded real-time operating system, and secure communications framework with IEC 61131-3 PLC programmability.

## Major Features and Benefits

- ▶ **Multiple Device Functions.** Use a single SEL-3555 RTAC as a protocol gateway, RTU, logic processor, PAC, engineering port server, event processor, and system-wide SER logger/viewer.
- ▶ **Proven Reliability.** Rely on the robust hardware of the SEL-3555 RTAC, designed and tested to withstand vibration, electrical surges, fast transients, and extreme temperatures that meet or exceed protective relay standards and IEEE 1613, Standard Environmental and Testing Requirements for Communications Networking Devices in Electric Power Substations.
- ▶ **Integrated Local Display.** Build custom human-machine interface (HMI) displays quickly and easily without the need for mapping data tags. Because the HMI uses the local video port and is also web-based, no special software is needed for viewing HMI displays.
- ▶ **Protection Against Malware and Other Cybersecurity Threats.** Protect your RTAC system with exe-GUARD<sup>®</sup>, which uses advanced cryptographic algorithms to authorize the execution of any program or service on the system. Any tasks not approved by the whitelist are blocked from operation.
- ▶ **Standard IEC 61131-3 Logic Design.** Create innovative logic solutions directly in ACCELERATOR RTAC by using any of the editor tools: Tag Processor, Structured Text, Ladder Logic, or Continuous Function Chart.
- ▶ **Single-Point Engineering Access.** Gain engineering access to station IEDs through a single serial port, external modem, or high-speed network connection.
- ▶ **User Security.** Assign individual user and role-based account authentication and strong passwords. Use Lightweight Directory Access Protocol (LDAP) for central user authentication.
- ▶ **Integrated Security Management.** Comply with NERC/CIP user authentication, logging, and port control requirements.
- ▶ **IEC 61850.** Integrate high-speed control schemes between the RTAC and relays with IEC 61850 GOOSE peer-to-peer messaging. Poll and send data sets and reports from other IEDs with IEC 61850 MMS client/server.
- ▶ **Redundant Power Supply.** Apply redundant power support with two load-sharing, hot-swappable power supply modules, enabling you to power the SEL-3555 RTAC from two independent power sources for maximum availability and without inverters.
- ▶ **Synchrophasor Technology.** Use the IEEE C37.118 client protocol to integrate synchrophasor messages from relays or PMUs in your system. These messages can be used for logic and control in the station or converted to DNP3 or other protocol for SCADA usage.

- ▶ **Standard Data Management.** Map and scale data points easily between protocols in small and large systems. You can also normalize IED data into common data types, time-stamp formats, and time zones.
- ▶ **Simple Setup With ACSELERATOR RTAC® SEL-5033 Software.** Build a system quickly by using preconfigured device templates for SEL relays and other communications connections. The Tag Processor provides methods to map data relationships between communications protocols visually.
- ▶ **PCIe Expandability.** Employ as many as four standard PCI/PCIe form factor expansion cards, enabling you to add as many as eight fiber-optic or copper Ethernet ports or 18 additional rear-panel (RJ45) serial ports.
- ▶ **Remote Management.** Use remote access with Intel vPro™ Active Management Technology to give you full access to system video, keyboard, mouse, and storage.
- ▶ **Versatile Display Interfaces.** Connect to a Digital Visual Interface (DVI) or DisplayPort to use simultaneous independent high-definition display interfaces. Other video connections, such as High Definition Multimedia Interface (HDMI), are available when using interface adapters. The two front-panel and four rear-panel USB ports provide keyboard and mouse control.
- ▶ **Flexible Protocol Conversion.** Apply any available client or server protocol on any serial or Ethernet port. Each serial port on the expansion card can be used in software-selectable EIA-232 or EIA-485. The two rear Ethernet ports can optionally be copper or fiber-optic connectors.

## Product Overview

### Functional Diagram

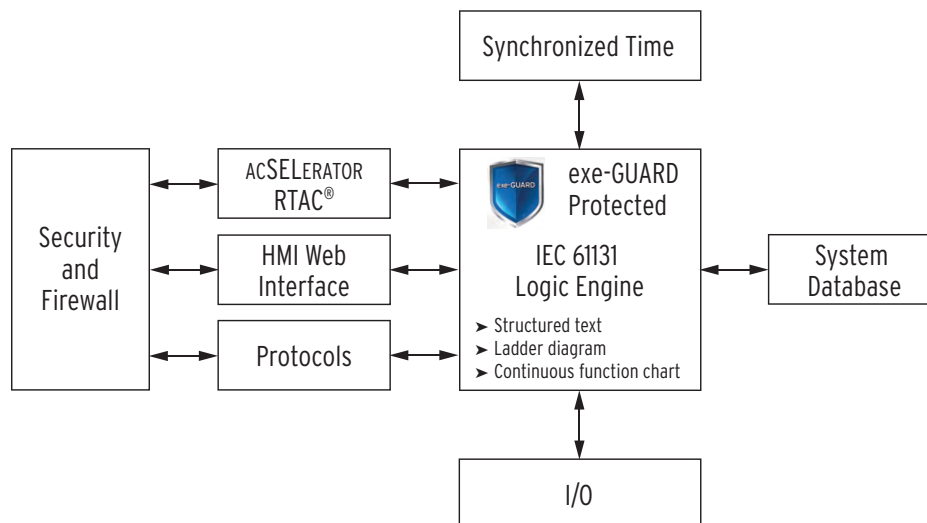

### IEC 61131 Logic Engine

As depicted in the functional diagram, each RTAC includes an IEC 61131 logic engine that is preconfigured to have access for all system tags, IED data, diagnostics, alarms, security events, and communications statistics for use integrating your system. The system has no functional separation between those tags mapped for communications protocols and those used in programmable logic. This architecture greatly simplifies system configuration effort because no additional selection is required to identify tags used by the logic engine. You simply use any needed IED data, calculated values, and system tags in deterministic logic for the control of critical applications.

Management of the task-processing sequence and solve rate in the RTAC is similar to that for traditional PLCs or PACs. The fastest processing rate is 4 ms for the main task and 1 ms for the automation task. Optimize the processor utilization by setting the processing rate no faster than necessary for your application.

Task processing in the logic engine includes protocol I/O, system management, and any custom logic programs you create using Structured Text (ST), Ladder Logic Diagram (LD), or Continuous Function Charts (CFC). CFC programs are a type of IEC 61131-3 Function Block Diagram (FBD) that provide more programming flexibility than standard FBDs. The ACSELERATOR RTAC software includes the IEC 61131-3 and Tag Processor editors you will use to manage any protocol information and custom logic needed for your system.

## Manage User Accounts and Alarms in Web Server

The built-in RTAC web interface provides the ability to manage user accounts and system alarms remotely. Each user account has a unique username, password, and assigned role that defines system permissions. The RTAC can also be configured to use LDAP central authentication for user account management. The system includes web pages for monitoring user logs and maintaining network policies.

Logged tag values and system events provide a system-wide Sequence of Events report. View logs online or use ODBC connectivity to download them to a central database.

You can also configure Ethernet connections and monitor system status from the web interface. All of the Ethernet ports can operate on independent networks, or you can bind them for failover operation.

## Flexible Engineering Access

Access Point Routers in the RTAC provide a means for creating transparent connections between any two ports. A transparent connection is a method for using the RTAC as a port server to connect remotely to an IED. Simple logic in the RTAC enables remote engineering access only through supervisory commands.

## Seamless System Configuration

ACSELERATOR RTAC is a Microsoft® Windows® compatible configuration software for offline and online use with the SEL-3555 RTAC. A project in ACSELERATOR RTAC contains the complete configuration, settings, and logic for an individual RTAC device. Preconfigured device templates are available for you to add all device and master connections to the project tree view.

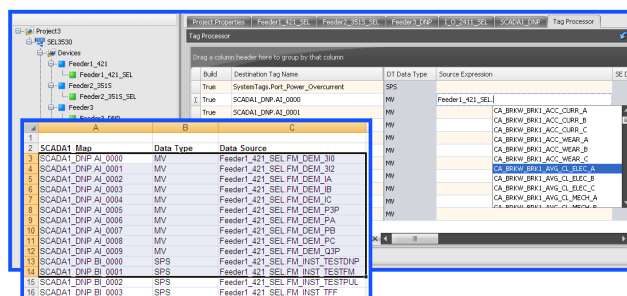

**Figure 1** Map Source and Destination Tags Using Tag Processor or Copy SCADA Maps Directly From Spreadsheet

Once you create the settings for a specific device connection, improve engineering efficiency by saving a custom device template for later use with similar projects. Share custom templates via email or network for even greater savings.

The Tag Processor view facilitates the mapping of operational data quickly between IEDs and SCADA. ACSELERATOR RTAC is compatible with Microsoft Excel® and other programs, so you can save time and increase accuracy by copying SCADA maps from the source.

There is no need to install or learn more than one software interface. Use the Structured Text, Ladder Diagram, or Continuous Function Chart editors included with ACSELERATOR RTAC to develop custom IEC 61131 logic.

## Data Concentration and Protocol Conversion

Configure each serial or Ethernet port to use any of the client, server, or peer-to-peer protocols available for the RTAC. For example, when you use IEEE C37.118 protocol to receive synchrophasor messages, you can map analog or Boolean tags and time stamps to DNP3 and send the data to SCADA very efficiently. You can also map data to IEC 61850 GOOSE messages for high-speed control schemes.

Additionally, when you need to define relay connections in a primary/backup arrangement, use the Tag Processor to map relay tags so that the master stations will receive power system information only from the active relay.

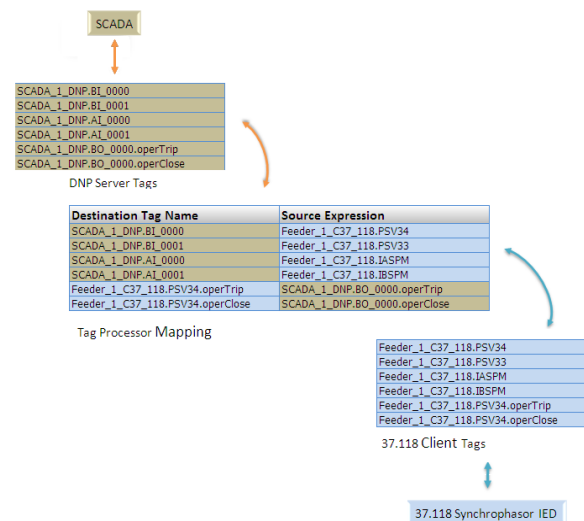

**Figure 2** Synchrophasor Data Map Seamlessly Into SCADA Connections

# Applications

## Substation SCADA, Report Retrieval, Engineering Access, and Alarm Notification

The RTAC can act as a data concentrator by using protocols such as IEC 61850 MMS client, Modbus®, DNP3, IEC 61850 GOOSE or MIRRORING BITS® communications to integrate both serial and Ethernet IEDs. Enable logging on any system or IED tag to view and archive a station-wide event record.

The RTAC Ethernet connection provides a means to remotely access the system to monitor logs and diagnostics. First, establish a remote connection with any IED connected to the RTAC through Engineering Access communications channels. Then use the ACCELERATOR QuickSet® SEL-5030 Software suite to manage protection and control settings for these relays remotely.

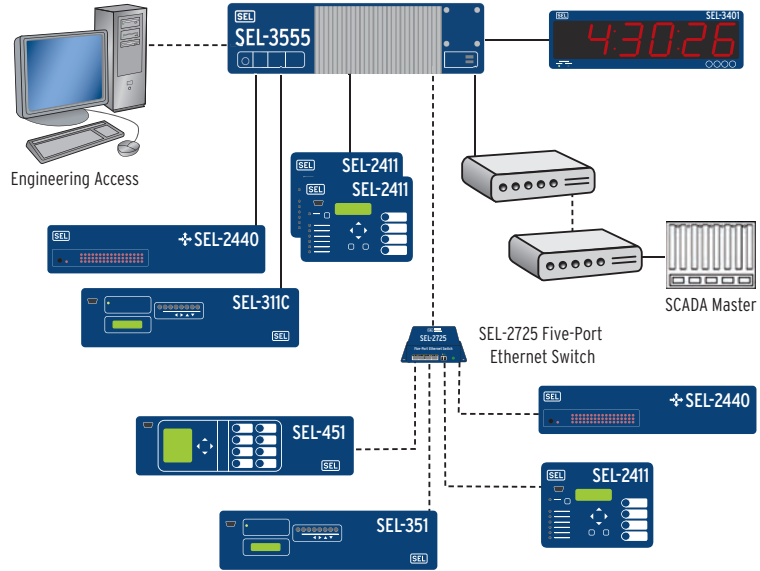

## Micro-Grid Automation and Control

The SEL-3555 RTAC provides the control and monitoring capabilities necessary to automate a micro-grid. Implement capacitor bank control, load-shedding schemes, power-grid reconfigurations, and power-source selection with the built-in logic processor in the RTAC. Coupled with the secure, redundant, and self-healing network capabilities of the SEL ICON®, as well as accurate time distribution to all IEDs, the RTAC provides the capability to control and monitor all aspects of a micro-grid as well as display data with the optional built-in HMI. Built-in protocols provide a gateway to local and remote SCADA systems. To complete system integration, control and monitor remote I/O with the SEL-2240 Axion and collect event reports from connected IEDs with ACCELERATOR TEAM® SEL-5045 Software.

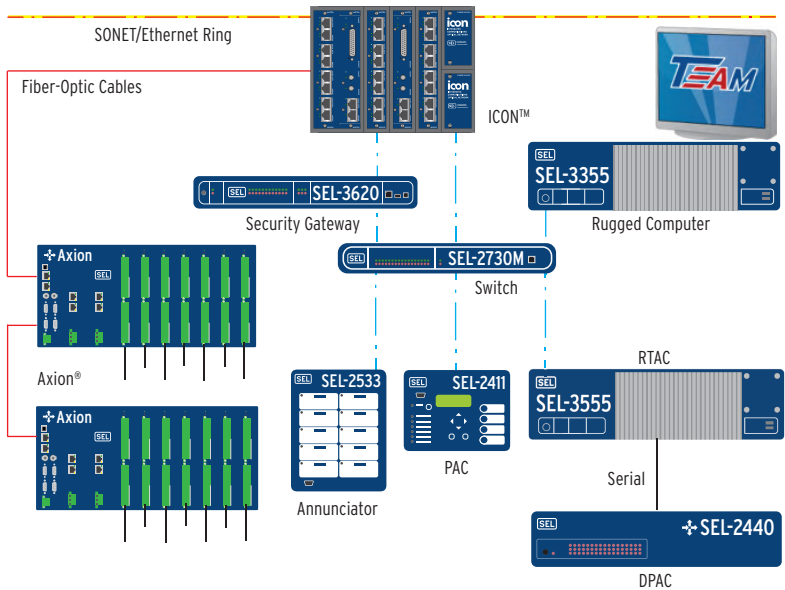

## Real-Time Control and Logic Processing

The built-in logic processor provides high-speed control and transfer of signals from SEL MIRRORED BITS devices, or other protocols. The RTAC can serve as the system controller and SCADA gateway to eliminate costly equipment (such as breakers, interposing relays, and wiring) while also reducing engineering and labor costs.

The intuitive ACCELERATOR RTAC software provides simple setup of analog and binary tags from any device in the system. Integrated tools scale values and create logic in a flexible IEC 61131-3 configuration environment.

You can take advantage of multiprotocol support to collect SCADA information, process control commands, and use NTP time synchronization through a single communications link to each Ethernet device.

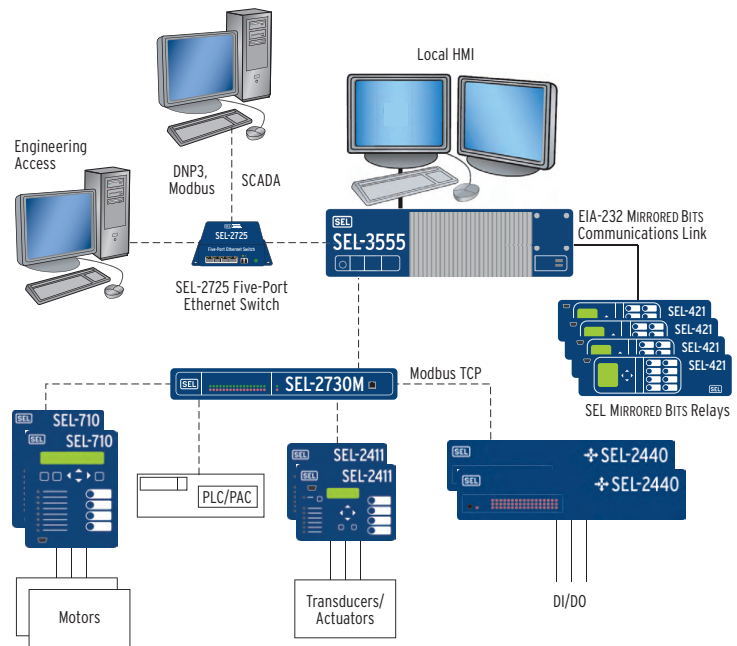

## Secure Communications and User Management

The RTAC and SEL accessories offer security for your automation network. Per-user security profiles provide compliance with role-based requirements. The system can employ intrusion detection, notification, and logging to help maintain perimeter integrity.

The RTAC includes security features so that your system complies with NERC/CIP requirements for auditing, logging, port control, web authentication, and password restrictions. The RTAC also supports central authentication through your existing LDAP server.

By including SEL serial and wireless encrypting devices with the RTAC, you can protect remote serial communication to recloser controls or other connected devices.

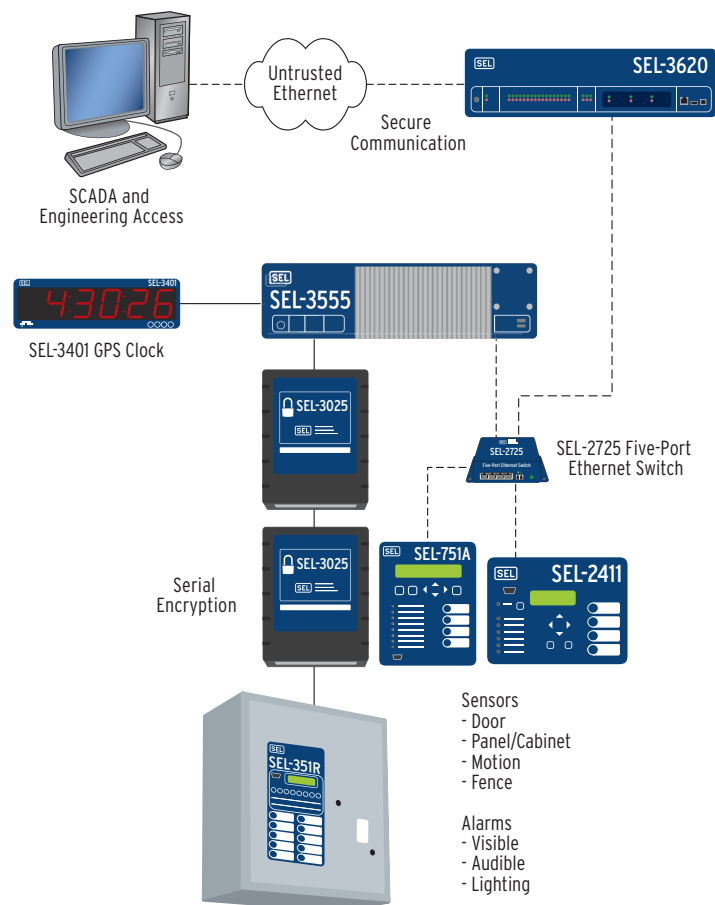



## Control Systems

The custom logic and communications protocols in the SEL-3555 RTAC, along with the I/O in the SEL-2411 and SEL-2440, permit you to implement complete control systems, whether you perform discrete sequences, continuous control, monitoring, or asset management. SEL subjects its products to tests for harsh environments, so you can be confident that your control system will work reliably in tough applications. Minimize loop wiring and simplify commissioning by installing controls close to process equipment and integrating them with industry standard communications protocols. Additionally, the SEL-3355 Computer can provide HMI and data archiving functions.

Use a powerful IEC 61131 logic engine to design custom control programs in the RTAC. You can set the logic solve rate and program execution order to meet your system requirements. Operate the RTAC as a master controller, and use SELOGIC® control equations in the SEL-2411 and SEL-2440 to perform distributed sequential or continuous control algorithms.

With a variety of physical interfaces and open protocol options, such as IEC 61850 GOOSE messaging, the RTAC makes system integration simple. It will reduce engineering time and complexity, so that you can focus on improving productivity and efficiency rather than on fixing communications problems.

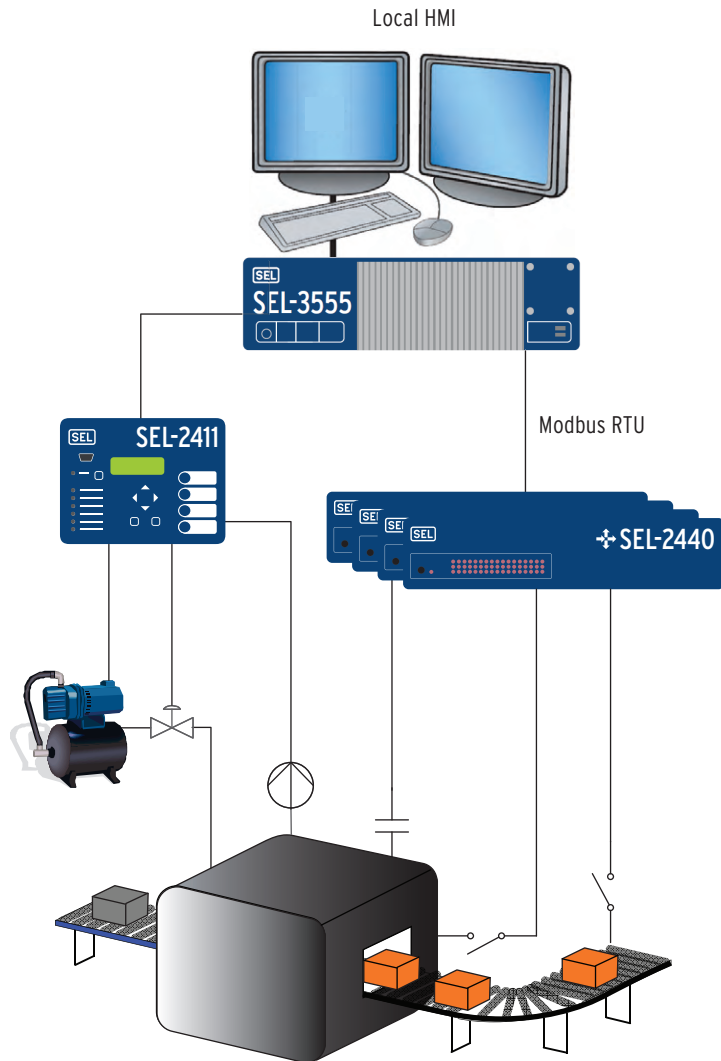

## Ordering Options

Ethernet Communication	Two rear Ethernet ports, 10/100BASE-T copper
Serial Communication	Two rear EIA-232 ports
Power Supply	125/250 Vdc 120/240 Vac
Environment	Conformal coating for chemically harsh and high-moisture environments
Software Options	Human-Machine Interface (HMI) IEC 61850 GOOSE IEC 61850 MMS client IEC 61850 MMS server File I/O library
Ethernet Expansion	Optional SEL-3390E4 PCIe x4 Expansion Card As many as 8 additional 10/100/1000 Mbps ports, copper or LC fiber SFP
Serial Expansion	Optional SEL-3390S8 PCIe x1 Expansion Cards As many as 18 additional EIA-232/422/485 ports (RJ45)

# Panel Features

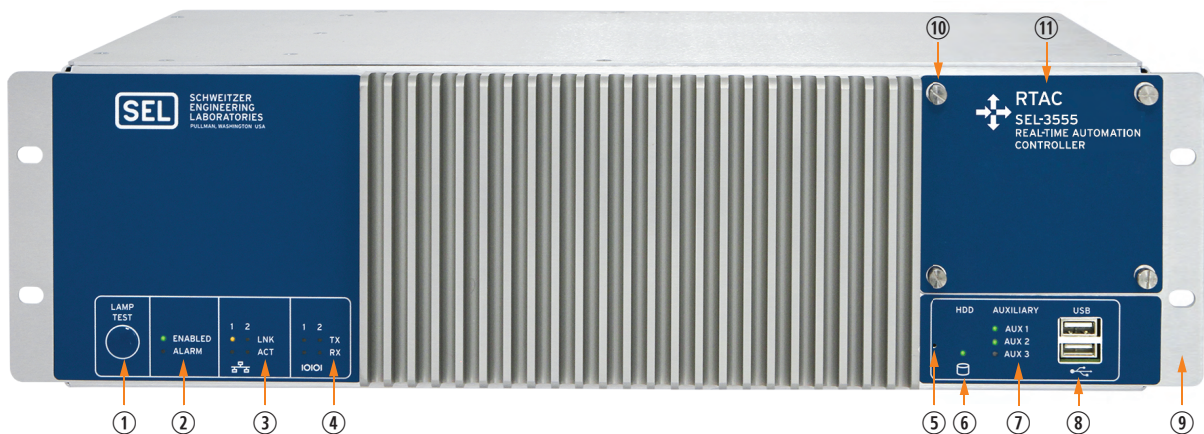

- ① LEDs may all be tested by holding down the **LAMP TEST** button.
- ② **ENABLED** LED provides operational status. Green indicates normal operation, and red indicates that the system is halted or booting, or that an alarm condition has occurred. The **ALARM** LED indicates a non-optimal system condition exists. The **ALARM** LED illuminates red whenever the alarm contact operates.
- ③ **LINK** and **ACT** LEDs indicate link status and network activity for each Ethernet port.
- ④ Transmit (**TX**) and Receive (**RX**) LEDs indicate activity on serial ports.
- ⑤ Reset pinhole may also be configured as a power button in the BIOS.
- ⑥ See SATA drive activity at a glance with the **HDD** LED indicator.
- ⑦ Program three bicolor **AUXILIARY** LEDs for your custom application.
- ⑧ Attach mouse and keyboard to any of the USB ports.
- ⑨ Rugged enclosure withstands EMI, RFI, shock, and vibration.
- ⑩ Easily access removable solid-state drive behind the front panel.
- ⑪ High contrast, white-on-blue lettering is highly legible even in dark areas.

**Figure 3 Front Panel**

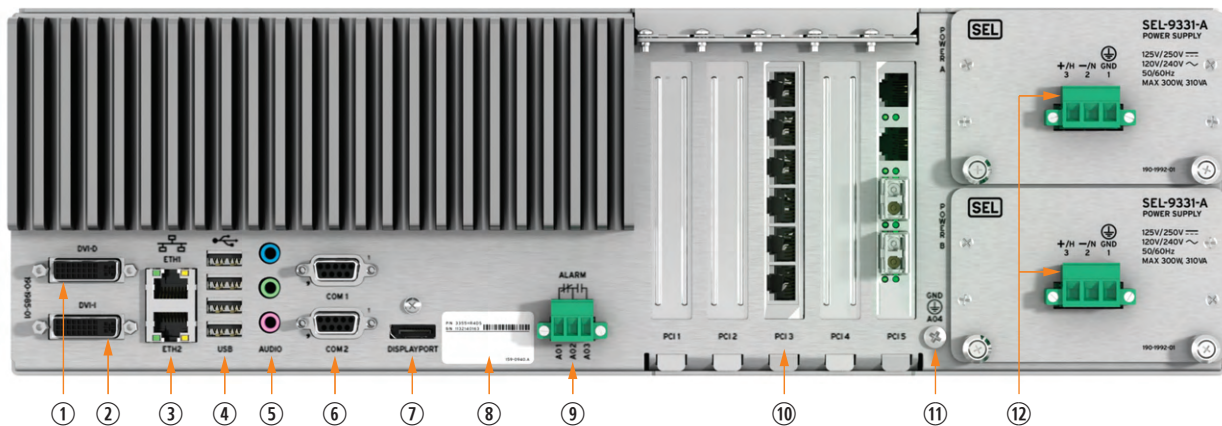

- ① Connect digital displays to the DVI-D video port.
- ② Connect digital or analog (VGA) displays to the DVI-I video port.
- ③ Network with two high-speed gigabit Ethernet ports. Ports may be bonded for redundancy or used individually.
- ④ Use any of the four USB 2.0 ports for keyboard and mouse connections.
- ⑤ Audio output.
- ⑥ Two built-in EIA-232 ports are BIOS configurable for +5 Vdc port power.
- ⑦ Connect monitors by using the DisplayPort technology video port to leverage higher performance features than any other digital interface.
- ⑧ Serial number label.
- ⑨ Wire a Form C alarm contact output either normally closed or normally open. The **ALARM** LED on the front provides indication of the alarm contact state.
- ⑩ Use SEL rugged PCI Express expansion cards for additional networking, serial, and IRIG-B input\*. One six-port serial expansion card included standard.
- ⑪ Attach chassis to ground.
- ⑫ Choose single or dual power supplies, and attach power from independent sources for even higher availability. Supplies load share and are hot-swappable for maximum online serviceability.

\*IRIG-B input only available through PCI expansion cards.

**Figure 4 Rear Panel**

# Dimensions

---

## Rack-Mount Chassis

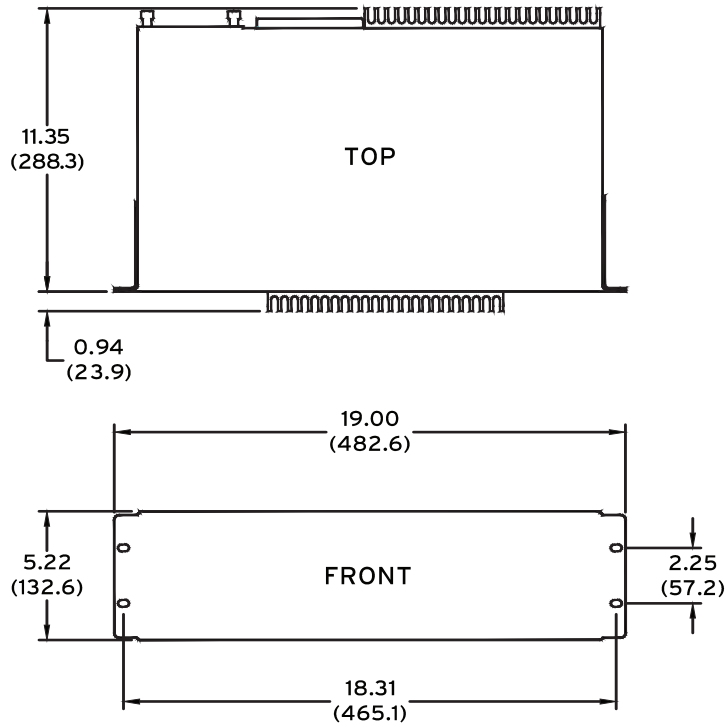

### LEGEND

← in →  
(mm)



# Panel-Mount Chassis

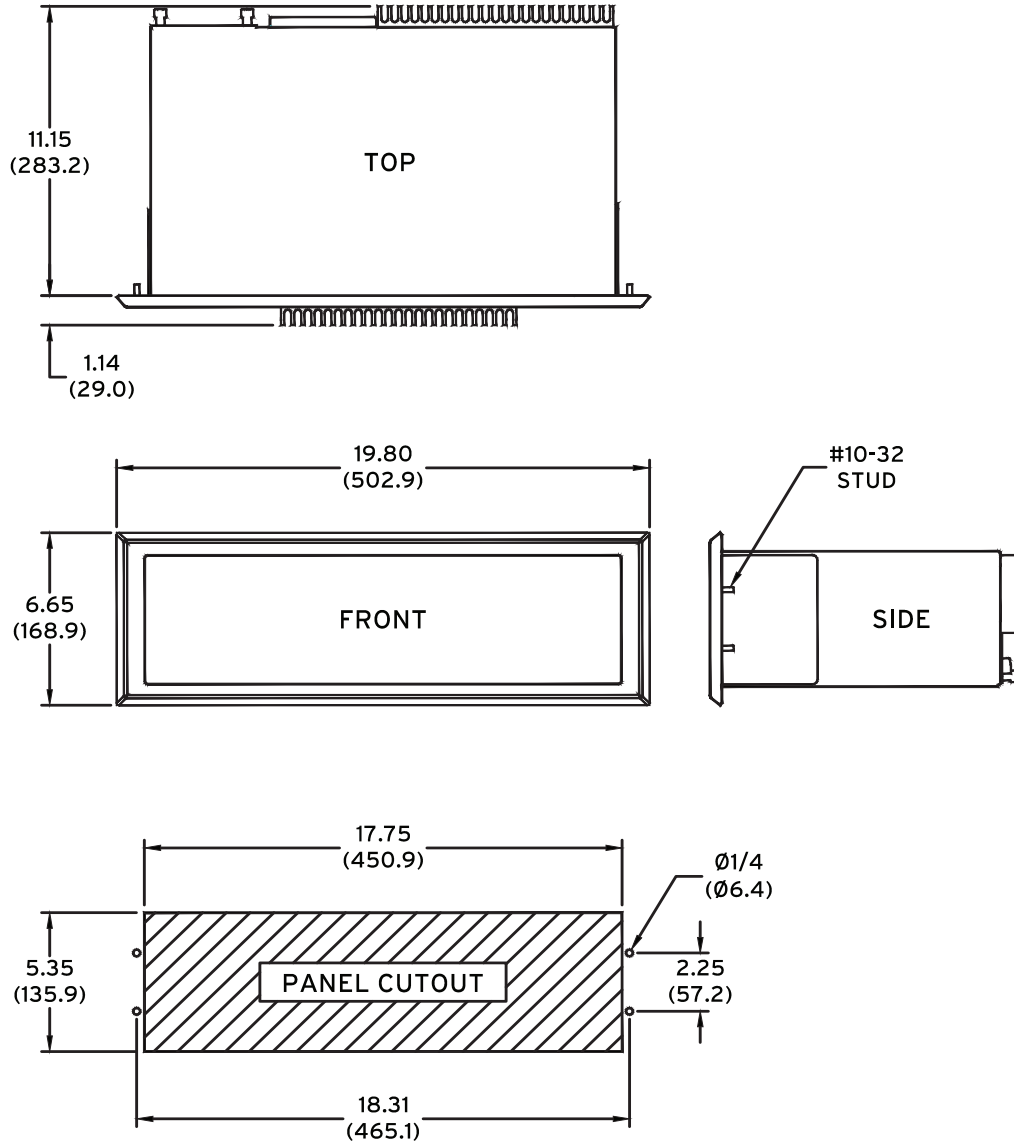

**LEGEND**  
in  
(mm)

# Specifications

## Compliance

Designed and manufactured under an ISO 9001 certified quality management system

47 CFR 15B, Class A

**Note:** This equipment has been tested and found to comply with the limits for a Class A digital device, pursuant to part 15 of the FCC Rules. These limits are designed to provide reasonable protection against harmful interference when the equipment is operated in a commercial environment. This equipment generates, uses, and can radiate radio frequency energy and, if not installed and used in accordance with the instruction manual, may cause harmful interference to radio communications. Operation of this equipment in a residential area is likely to cause harmful interference in which case the user will be required to correct the interference at his own expense.

UL Recognized to U.S. and Canadian safety standards (File E220228; NRAQ2, NRAQ8)

CE Mark

UKCA Mark

## General

### Operating System

SEL Linux® Yellowstone running Linux kernel 3.x with real-time preemption patches

### CPU

Intel Core i7-3555LE Dual-Core

Speed: 2.5 GHz base, 3.2 GHz turbo

Cache: 2 x 256 KB L2, 4 MB L3

Intel Core i7-3612QE Quad-Core

Speed: 2.1 GHz base, 3.1 GHz turbo

Cache: 4 x 256 KB L2, 6 MB L3

### RAM

8 GB DDR3 ECC PC3-10600 (1333 MHz)

### Chipset

Intel QM77 Express Chipset

### Mass Storage

1 Internal Drive Bay: One 2.5" SSD  
SATA II 3.0 Gb/s

### Video

Intel HD Graphics 4000 Controller

Dual Independent Displays From 2 of the 3 Outputs: DVI-I (digital + VGA) maximum resolution 1920 x 1200 @ 32 bpp  
DVI-D (digital only) maximum resolution 1920 x 1200 @ 32 bpp  
DisplayPort maximum resolution 1920 x 1200 @ 32 bpp

### Audio

IDT 92HD91 HD Audio codec

3 Analog 3.5 mm TRS Jacks: Line input  
Line/headphone output  
Microphone input

### USB

4 Rear-Panel Ports, 2 Front-Panel Ports  
USB 2.0 Compliant  
800 mA Current Limit Each

## Expansion Cards

5 Half-Length, Full-Height PCI Expansion Card Slots: 2 PCIe x4 (Revision 2.0)  
2 PCIe x1 (Revision 2.0)  
1 32-bit 5 V PCI (not used)

## Ethernet

2 Rear-Panel 1 Gbps Copper RJ45 Ports

ETH1: Intel 82579LM, 10/100/1000 Mbps  
RJ45 copper

ETH2: Intel 82574L, 10/100/1000 Mbps  
RJ45 copper

Optional SEL-3390E4 PCIe x4 Expansion Cards: As many as 8 additional 10/100/1000 Mbps ports, copper or LC fiber SFP

## Serial Ports

Standard Ports: 2 EIA-232 ports, DB-9 connectors, 300 to 115200 bps  
Included SEL-3390S8 PCIe expansion provides 6 additional EIA-232/422/485 ports, RJ45 connectors, 300 to 921600 bps

Optional SEL-3390S8 PCIe x1 Expansion Cards: As many as 18 additional EIA-232/422/485 ports, RJ45 connectors, 300 to 921600 bps

On-board and SEL-3390S8 serial ports meet EIA/TIA-562 specifications

## Time-Code Input/Output

Available With SEL-3390S8 Expansion Card

Connector: RJ45 serial port

Time-Code: Demodulated IRIG-B TTL compatible

**Note:** Output generated from either IRIG-B input or SEL-3555 clock.

## Real-Time Clock/Calendar

Battery Type: IEC No. BR2330A Lithium

Battery Life: 10 years with power  
2 years without power

## BIOS

Phoenix SecureCore Tiano™ UEFI

## Trusted Platform Module

Integrated TPM 1.2

## Intel Active Management Technology

Intel AMT v8.0

## Security Features

Account Management: User Accounts  
User Roles  
LDAP Central Authentication  
RADIUS Central Authentication  
Strong Passwords  
Inactive Account Logouts

Intrusion Detection: Access/Audit Logs  
Alarm LED  
Alarm Contact

Encrypted Communications: SSL/TLS, SSH  
HTTPS

## Automation Features

### Protocols

#### Client

DNP3 Serial, DNP3 LAN/WAN, Modbus RTU, Modbus TCP, SEL ASCII, SEL Fast Messaging, LG 8979, IEEE C37.118, IEC 61850 MMS, CP2179, IEC 60870-5-103, EtherNet/IP Explicit Message Client

#### Server

DNP3 Serial, DNP3 LAN/WAN, Modbus RTU, Modbus TCP, SEL Fast Messaging, LG 8979, SES-92, IEC 61850 MMS, IEC 60870-5-101/104, IEEE C37.118, FTP/SFTP, CDC Type II, EtherNet/IP Implicit Message Adapter

#### Peer-to-Peer

IEC 61850 GOOSE, SEL MIRRORRED BITS Communications, Network Global Variables (NGVL), Parallel Redundancy Protocol

#### Fieldbus

EtherCAT Client

#### Engineering Access

Modes: SEL Interleaved, Direct  
Port Server: Map Serial Ports to IP Ports  
Secure Web Server: Diagnostic and Communications Data

## Network Time Protocol (NTP) Modes

NTP Client: As many as three configurable servers

NTP Server

## Precise Time Protocol (PTP)

PTP Client: Peer delay request and end-to-end path delay supported

## Power Supply

See *Table 1* for additional burden information.

### SEL-9331 160 W LV Power Supply

Voltage Rating: 48 Vdc  
Voltage Range: 38–58 Vdc  
Maximum Constant Burden: 149 W  
Maximum Peak Burden: 225 W  
DC Ripple: <15% rated voltage  
Peak Inrush: 20 A  
Insulation: 3100 Vdc  
Isolated From Chassis Ground: Yes

### SEL-9331 160 W HV Power Supply

Voltage Ratings: 125/250 Vdc or 120/220/240 Vac;  
50/60 Hz  
DC Range: 100–300 Vdc  
Maximum DC Dropout: 88 Vdc  
AC Range: 85–264 Vac  
Frequency Range: 45–65 Hz  
Maximum Constant Burden: 155 W, 160 VA  
Maximum Peak Burden: 240 W, 248 VA  
DC Ripple: <15% Rated Voltage  
Peak Inrush: 20 A  
Insulation: 3100 Vdc

Power Factor: >0.9 (at full load)

Isolated From Chassis Ground: Yes

## Recommended External Overcurrent Protection

Breaker Type: Standard  
Breaker Rating: 20 A at 250 Vdc  
Current Breaking Capacity: 10 kA  
Grounded Neutral Systems: Device in series with the HOT or energized conductor  
DC and Isolated Systems: Device in series with both conductors

See *Table 1* for additional burden information.

## Fuse Ratings

### LV Power Supply Fuse

Rating: 15 A  
Maximum Rated Voltage: 500 Vdc, 500 Vac  
Breaking Capacity: 20 kA at 500 Vdc  
Type: Time-lag T

### HV Power Supply Fuse

Rating: 5 A  
Maximum Rated Voltage: 250 Vdc, 277 Vac  
Breaking Capacity: 1500 A at 277 Vac  
Type: Time-lag T

Heater Fuses F2, F3: 5 A, 125 V slow blow  
125 Vdc/50 A break rating

Fuses are not serviceable.

## Alarm Output Contact

Per IEC 60255-0-20:1974, using the simplified method of assessment.

Output Type: Relay, Form C, break-before-make  
Power Supply Burden: <1 W maximum  
Mechanical Life: 2000000 operations  
Operational Voltage: 250 Vac/Vdc  
Make: 30 A at 250 Vdc  
Carry: 6 A continuous at 70°C  
1 s Rating: 50 A  
MOV Protection: 270 Vac/360 Vdc, 75 J

Insulation Voltage: 300 Vac/Vdc

Pickup Time: <8 ms

Dropout Time: <8 ms

### Breaking Capacity (10000 operations):

24 V	0.75 A	L/R = 40 ms
48 V	0.50 A	L/R = 40 ms
125 V	0.30 A	L/R = 40 ms
250 V	0.20 A	L/R = 40 ms

### Cyclic Capacity (2.5 cycles/second):

24 V	0.75 A	L/R = 40 ms
48 V	0.50 A	L/R = 40 ms
125 V	0.30 A	L/R = 40 ms
250 V	0.20 A	L/R = 40 ms

**Terminal Connections****Compression Screw Terminal****Power Wiring**

Insulation:	300 V min.
Size:	12–18 AWG

**Alarm Wiring**

Insulation:	300 V min.
Size:	12–18 AWG

**Tightening Torque**

Minimum:	0.6 Nm (5 in-lb)
Maximum:	0.8 Nm (7 in-lb)

**Crimp Ferrule Recommended****Mounting Ear Tightening Torque**

Minimum:	0.18 Nm (1.6 in-lb)
Maximum:	0.25 Nm (2.2 in-lb)

**Grounding Screw****Ground Wiring**

Insulation:	300 V min.
Size:	12 AWG, length <3 m

**Tightening Torque**

Minimum:	0.9 Nm (8 in-lb)
Maximum:	1.4 Nm (12 in-lb)

**Ring Terminal Recommended****Serial Port****Tightening Torque**

Minimum:	0.6 Nm (5 in-lb)
Maximum:	0.8 Nm (7 in-lb)

**Video Port****Tightening Torque**

Minimum:	0.6 Nm (5 in-lb)
Maximum:	0.8 Nm (7 in-lb)

**Operating Temperature Range**

i7-3555LE CPU:	–40° to +75°C (–40° to +167°F)
i7-3612QE CPU:	–40° to +60°C (–40° to +140°F)

**Note:** Not applicable to UL applications.

**Storage Temperature**

–40° to +85°C (–40° to +185°F)

**Relative Humidity**

5% to 95% noncondensing

**Maximum Altitude**

2000 m

**Atmospheric Pressure**

80–110 kPa

**Overvoltage Category**

Category II

**Pollution Degree**

2

**Insulation Class**

1

**Weight (Maximum)**

9.072 kg (20 lb)

**Type Tests****Electromagnetic Compatibility Emissions**

Conducted Emissions: IEC 60255-25:2000  
FCC 15.107:2014  
Severity Level: Class A

Radiated Emissions: IEC 60255-25:2000  
CISPR 22:2008  
FCC 15.109:2014  
IEC 61850-3:2013  
Severity Level: Class A

**Electromagnetic Compatibility Immunity**

Conducted RF: IEC 60255-26:2013  
IEC 61000-4-6:2008  
IEC 61850-3:2013  
Severity Level: 10 Vrms

Electrostatic Discharge: IEC 60255-26:2013  
IEC 61000-4-2:2008  
IEC 61850-3:2013  
IEEE 1613-2003  
IEEE C37.90.3-2001  
Severity Level:  
2, 4, 6, 8 kV contact discharge;  
2, 4, 8, 15 kV air discharge

Fast Transient/Burst: IEC 60255-26:2013  
IEC 61000-4-4:2012  
IEC 61850-3:2013  
Severity Level: Class A  
4 kV, 5 kHz on power supply and  
outputs;  
2 kV, 5 kHz on communications lines

Magnetic Field: IEC 61000-4-8:2009  
IEC 61850-3:2013  
Severity Level:  
1000 A/m for 3 s  
100 A/m for 1 m  
IEC 61000-4-9:2001  
Severity Level: 1000 A/m  
IEC 61000-4-10:2001  
Severity Level: 100 A/m

Power Supply: IEC 60255-26:2013  
IEC 61000-4-11:2004  
IEC 61000-4-17:2009  
IEC 61000-4-29:2000  
IEC 61850-3:2013  
IEEE 1613-2003

Radiated Radio Frequency: IEC 60255-26:2013  
IEC 61000-4-3:2010  
IEC 61850-3:2013  
Severity Level: 10 V/m  
IEEE C37.90.2-2004  
IEEE 1613-2003  
Severity Level: 35 V/m

Surge Withstand Capability:	IEC 60255-26:2013 IEC 61000-4-18:2006 Severity Level: Power supply and outputs 2.5 kV peak common mode 1.0 kV peak differential mode Communications ports 1.0 kV peak common mode IEEE C37.90.1-2002 IEEE 1613-2003 Severity Level: 2.5 kV oscillatory 4 kV fast transient	Dry Heat:	IEC 60068-2-2:2007 IEC 61850-3:2013 IEEE 1613-2003 Severity Level: 16 hours at 60°C (i7-3612QE CPU) 16 hours at 75°C (i7-3555LE CPU)
Surge Immunity:	IEC 60255-22-5:2008 IEC 61000-4-5:2005 1 kV line-to-line 2 kV line-to-earth 1 kV communications ports	Vibration:	IEC 60255-21-1:1988 IEC 61850-3:2013 Severity Level: Endurance Class 2 Response Class 2 IEC 60255-21-2:1988 Severity Level: Shock Withstand, Bump Class 1 Shock Response Class 2 IEC 60255-21-3:1993 Severity Level: Quake Response Class 2 IEEE 1613-2003 Severity Level: V.S.4
<b>Environmental</b>		<b>Safety</b>	
Cold:	IEC 60068-2-1:2007 IEC 61850-3:2013 IEEE 1613-2003 Severity Level: 16 hours at -40°C	Enclosure Protection:	IEC 60529:2001 + CRGD:2003 Severity Level: IP30
Damp Heat, Cyclic:	IEC 60068-2-30:2005 IEC 61850-3:2013 IEEE 1613-2003 Severity Level: 12 + 12-hour cycle 25° to 55°C, 6 cycles, 95% r.h.	Dielectric Strength:	IEC 60255-5:2000 IEC 60255-27:2013 IEEE 1613-2003 IEEE C37.90-2005 Severity Level: 3100 Vdc on power supply 2500 Vac on contact output 1500 Vac Ethernet ports Type tested for one minute
		Impulse:	IEC 60255-5:2000 IEC 60255-27:2013 IEEE 1613-2003 Severity Level: 5 kV power supply, contact outputs 1.5 kV Ethernet ports

**Table 1 System Power Consumption**

Power Consumption (Watts) <sup>a</sup>			
Component	Minimum	Typical	Maximum
Base System (Dual-Core CPU, 1 PSU, 8 GB RAM, 30 GB SSD, 1 serial card):	31 W	42 W	60 W
<b>Additional Consumption From Optional Components</b>			
Quad-Core CPU:	+2 W	+5 W	+13 W
2nd Power Supply:	+10 W	+10 W	+13 W
SEL-3390E4 Ethernet Card:	+6 W	+8 W	+10 W
SEL-3390S8 Serial Card:	+4 W	+5 W	+7 W
Chipset Heater <sup>b</sup>			
cold startup (<5°C [41°F]):	N/A	N/A	+90 W
continuous operation (0°C [32°F]):	0 W	+5 W	+10 W
continuous operation (-40°C [-40°F]):	0 W	+20 W	+40 W

<sup>a</sup> Minimum: 0% load on all components; minimum power consumption started and idle. Typical: 25-50% load on all components; good indication of most application loads. Maximum: 100% load on all components; generally cannot be reached in normal applications.

<sup>b</sup> Chipset heaters operate at low temperatures to keep the CPU and PCH within specified operating limits.



# Notes

---



---

© 2015–2022 by Schweitzer Engineering Laboratories, Inc. All rights reserved.

All brand or product names appearing in this document are the trademark or registered trademark of their respective holders. No SEL trademarks may be used without written permission. SEL products appearing in this document may be covered by U.S. and Foreign patents.

Schweitzer Engineering Laboratories, Inc. reserves all rights and benefits afforded under federal and international copyright and patent laws in its products, including without limitation software, firmware, and documentation.

The information in this document is provided for informational use only and is subject to change without notice. Schweitzer Engineering Laboratories, Inc. has approved only the English language document.

This product is covered by the standard SEL 10-year warranty. For warranty details, visit [selinc.com](http://selinc.com) or contact your customer service representative.

**SCHWEITZER ENGINEERING LABORATORIES, INC.**

2350 NE Hopkins Court • Pullman, WA 99163-5603 U.S.A.

Tel: +1.509.332.1890 • Fax: +1.509.332.7990

[selinc.com](http://selinc.com) • [info@selinc.com](mailto:info@selinc.com)

