

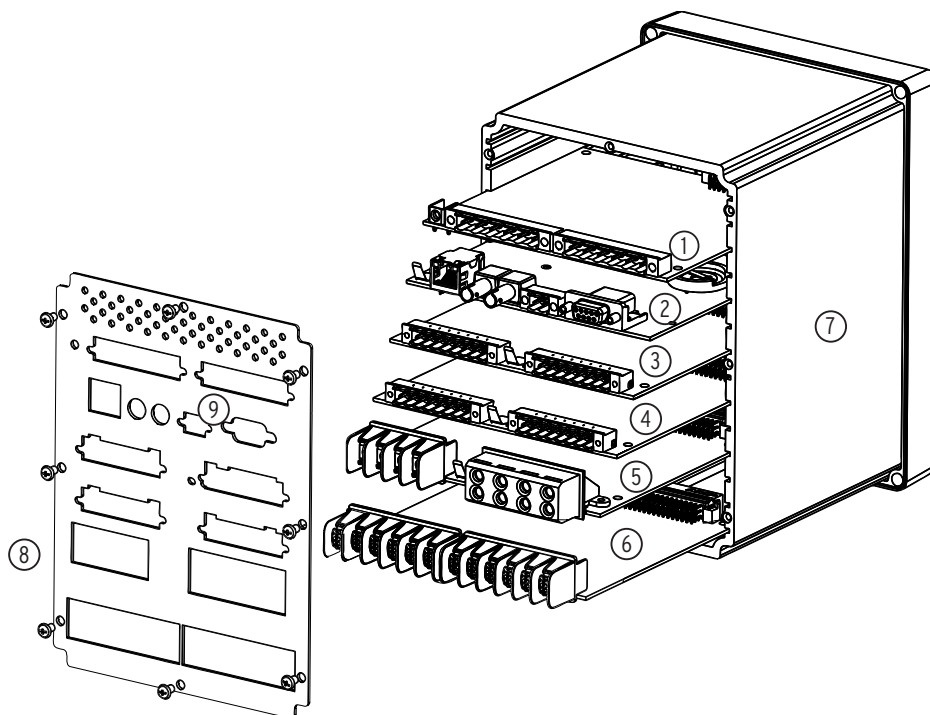

SEL-751 Card Options



- ① SELECT Power Supply With I/O (Slot A)
- ② SELECT Processor and Communications Card (Slot B)
- ③ SELECT I/O Expansion Card (Slot C: see table)
- ④ SELECT I/O Expansion Card (Slot D: see table)
- ⑤ SELECT I/O Expansion Card (Slot E: see table).
- ⑥ SELECT 4 ACI/3 AVI or 4 ACI Card (Slot Z)
- ⑦ Device Case
- ⑧ Rear-Panel Mounting Screws
- ⑨ Rear Panel

Refer to the Model Option Table on the SEL website for ordering details

Card Type	Rear-Panel Slot					
	A	B	C	D	E	Z
SELECT PSIO/2 DI/3 DO ^a	●	n/a	n/a	n/a	n/a	n/a
SELECT CPU/COM ^a	n/a	●	n/a	n/a	n/a	n/a
SELECT EIA-232/EIA-485	n/a	n/a	●	n/a	n/a	n/a
SELECT DeviceNet	n/a	n/a	●	n/a	n/a	n/a
SELECT 3 DI/4 DO/1 AO (one card per relay)	n/a	n/a	●	●	●	n/a
SELECT 4 DI/4 DO	n/a	n/a	●	●	●	n/a
SELECT 4 DI/3 DO (1 Form B, 2 Form C)	n/a	n/a	●	●	●	n/a
SELECT 8 DI	n/a	n/a	●	●	●	n/a
SELECT 14 DI	n/a	n/a	●	●	●	n/a
SELECT 8 DO	n/a	n/a	●	●	●	n/a
SELECT 8 AI	n/a	n/a	●	●	●	n/a
SELECT 4 AI/4 AO (one card per relay)	n/a	n/a	●	●	●	n/a
SELECT 10 RTD	n/a	n/a	n/a	●	n/a	n/a
SELECT 2 AVI/4 AFDI (MOT...x70x...)	n/a	n/a	n/a	n/a	●	n/a
SELECT 2 AVI/4 AFDI (MOT...xL0x...)	n/a	n/a	n/a	n/a	●	n/a
SELECT 2 AVI/7 DI (MOT...x7Xx...) where X = A to H	n/a	n/a	n/a	n/a	●	n/a

Card Type	Rear-Panel Slot					
	A	B	C	D	E	Z
SELECT 2 AVI/7 DI (MOT...xLXx...) where X = A to H	n/a	n/a	n/a	n/a	●	n/a
SELECT 8 AFDI (MOT...x77x...)	n/a	n/a	n/a	n/a	●	n/a
SELECT 4 ACI/3 AVI (MOT...x81/82/83/85/86/87x...)	n/a	n/a	n/a	n/a	n/a	●
SELECT 4 ACI/3 AVI (MOT...xL1/L2/L3/L5/L6/L7x...)	n/a	n/a	n/a	n/a	n/a	●
SELECT 4 ACI/3 AVI LEA (MOT...x7Lx...)	n/a	n/a	n/a	n/a	n/a	●
SELECT 4 ACI (MOT...xA1/A2/A3/A5/A6/A7x...)	n/a	n/a	n/a	n/a	n/a	●

^a Refer to the SEL-751 Model Option Table (MOT) for power supply and CPU board variants.

The SEL-751 offers flexibility in tailoring I/O to your specific application. The SEL-751 has six rear-panel slots, labeled as Slots A, B, C, D, E, and Z. Slots A, B, and Z are base unit slots, each associated with a specific function. Optional digital/analog I/O cards are available for the SEL-751 in Slots C, D, and E. Optional communications cards are available only for Slot C, an RTD card is available only for Slot D, voltage/current cards (conventional or LEA inputs) or current only cards are available only on Slot Z, and a voltage/arc-flash card or a voltage/7 digital inputs card is available for Slot E. The previous figure and table show the slot allocations for the cards.

Because installations differ substantially, the SEL-751 offers a variety of card configurations that provide options for an array of applications. Choose the combination of option cards most suited for your application.

Dangers, Warnings, and Cautions

DANGER

Disconnect or de-energize all external connections before opening this device. Contact with hazardous voltages and currents inside this device can cause electrical shock resulting in injury or death.

WARNING

Have only qualified personnel service this equipment. If you are not qualified to service this equipment, you can injure yourself or others, or cause equipment damage.

WARNING

To install an option card, the relay must be de-energized and then re-energized. When re-energized, the relay will reboot. Therefore, de-energize the protected equipment before installing the option card to prevent damage to the equipment.

CAUTION

Equipment components are sensitive to electrostatic discharge (ESD). Undetectable permanent damage can result if you do not use proper ESD procedures. Ground yourself, your work surface, and this equipment before removing any cover from this equipment. If your facility is not equipped to work with these components, contact SEL about returning this device and related SEL equipment for service.

Card Installation for Slots C, D, E, and Z

Perform the following procedure to install or replace any one of the cards into Slots C, D, E, or Z of the base unit:

1. Save the settings and event report data before installing the new card in the relay.
2. Remove the power supply voltage ① from terminals A01+ and A02-, and then remove the ground wire from the green ground screw.
3. Disconnect all the connection plugs.
4. Remove the eight screws on the rear ⑧ and remove the rear cover.
5. Remove the plastic filler plate covering the slot associated with the card being installed.
6. Insert the card in the correct slot.

Make sure the contact fingers on the printed circuit board are bent at an approximate 130-degree angle relative to the board for proper electromagnetic interference protection.

7. Before reattaching the rear cover, check for and remove any foreign material that may remain inside the SEL-751 case.

8. Carefully reattach the rear cover.
9. Reinstall the eight screws that secure the rear cover to the case ⑧.
10. Apply power supply voltage ① to terminals A01+ and A02-, and reconnect the ground wire to the green ground screw.

If you have a two-line display front panel, perform *Step 11* through *Step 19*; if you have a touchscreen display front panel, proceed to *Step 20*.

11. If the card is in the proper slot, the front panel displays the following:

```
STATUS FAIL
X Card Failure
```

If you *do not* see this message and the **ENABLED LED** is turned on, the card was inserted in the wrong slot. Begin again at *Step 2*.

12. Press the **ESC** pushbutton.
13. Press the **Down Arrow** pushbutton until **STATUS** is highlighted.
14. Press the **ENT** pushbutton.

The front panel displays the following:

```
STATUS
Relay Status
```

15. Press the **ENT** pushbutton.

The front panel displays the following:

```
Serial Num
00000000000000000000000000000000
```

16. Press the **ENT** pushbutton.

The front panel displays the following:

```
Confirm Hardware
Config (Enter)
```

17. Press the **ENT** pushbutton.

The front panel displays the following:

```
Accept New Config?
No Yes
```

18. Select **Yes** and press the **ENT** pushbutton.

The front panel displays the following:

```
Config Accepted.
Enter to Reboot
```

19. Press **ENT** and proceed to *Step 22*.

20. Wait for the Device Status screen to appear, and then verify the new part number and tap **Yes** to confirm the new configuration.

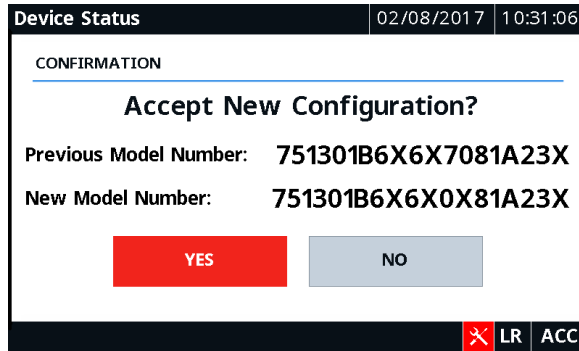

21. Tap OK on the notification screen to reboot the relay.
22. Use the **PARTNO** command from Access Level C to enter the exact part number of the relay after the relay restarts and the **ENABLED** LED is turned on to indicate the card was installed correctly.

After reconfiguration, the relay updates the part number, except for the digits shown below. These digits remain unchanged, i.e., these digits retain the same character as before the reconfiguration. A communications card (DeviceNet or EIA-232/485) installed in Slot C will be reflected as an empty slot in the part number. A regular 4 DI/4 DO card and a hybrid 4 DI/4 DO card have the same device ID. When interchanging these two cards, the part number for the respective slots should be updated manually. Use the **STATUS** command to view the part number.

```
PART NUM = 751001B5X1X7086020X
            ↑↑↑↑↑↑↑↑↑↑↑↑
            1 2 3 4 5 6 7 8 9 10 11
```

23. Update the side-panel drawing with the drawing sticker provided in the option card kit. If necessary, replace the rear panel with the one applicable for the card and attach the terminal marking label provided with the card to the rear-panel cover. Also, contact SEL for an updated product serial number label with the updated part number.
24. Reconnect all connection plugs, and add any additional wiring/connectors required by the new card.

Slot B CPU Card Replacement

Before replacing the Slot B card, do the following:

1. Ensure that the card has the latest firmware from the factory.
2. Review the firmware revision history for the changes that were made; note that new settings added, if any, might affect existing settings in the relay or its application.
3. Save all the settings and event reports before replacing the card.
4. If the IEC 61850 protocol option was used previously, verify that the IEC 61850 protocol is still operational after the replacement. If not, reenable it. Refer to *Protocol Verification for Relays With IEC 61850 Option* in *Appendix B: Firmware Upgrade Instructions* of the instruction manual.

Perform the following steps to replace the existing CPU card with a new card.

1. Turn off the power to the relay.
2. Use a ground strap between yourself and the relay.
3. Disconnect the terminal blocks and CT/PT wires.
4. Remove the rear panel.
5. Remove the card from its slot and insert the new card.
6. Attach the rear panel (new if applicable) and reconnect the terminal blocks and CT/PT wires.

7. Apply new side stickers to the relay.
8. Turn on the relay and log in via the terminal emulation software.
9. Issue the **STA** command and accept the new configuration.
10. From Access Level 2, type **CAL** to enter Access Level C.
Do not modify any settings other than those listed in this procedure.
The default password for Access Level C is CLARKE.
11. From Access Level C, issue the **SET C** command.
12. Update the relay serial number and part number to the appropriate values, type **END**, and then save the settings.
13. Issue the **STA C** command to reboot the relay.
14. Issue the **STA** command to verify that the serial and part numbers of your relay are correct.

Slot A Power Supply Card

If you are replacing the power supply card, change the part number accordingly using the **PARTNO** command from Access Level C. Install new side stickers on the relay.

