



# SEL-9250215 Accessory Mounting Kit for SEL-351RS Kestrel Recloser Controls

## Field Installation Instructions

### **⚠ DANGER**

Disconnect electrical supply to the recloser control cabinet prior to installing this kit or any other equipment. Contact with instrument terminals may cause electric shock that can result in injury or death.

### **⚠ CAUTION**

Disconnect the 24 V battery inside the recloser control cabinet to avoid possible equipment damage on the dc system.

Refer to *Figure 1*.

**NOTE:** No drilling required.

- Step 1. The two 16-inch (vertical) C-channels attach to the #10-32 studs already present on the inside back surface of the SEL-351RS Kestrel Recloser Control cabinet. These 16-inch rails should be installed first. Use the nuts and fender washers provided (refer to *Figure 1*).
- Step 2. The location of the 13-inch (horizontal) C-channels depends on the size and orientation of the accessories to be mounted. It is usually easier to attach accessories to the 13-inch horizontal C-channels prior to installing the C-channels in the cabinet. Use the supplied screws and washers as required to secure the equipment to the channel nuts as shown in *Figure 1*. Different lengths of screws are provided to allow for different mounting tab thicknesses. If you need more screws or different sizes than those provided, be sure to get #10-32 thread.
- Step 3. After installing the accessories on the horizontal channel rails, mount them on the vertical C-channels previously installed in *Step 1*. Use the channel nuts and #10-32 x 3/8-inch screws, adjusting the height of the channels before tightening the screws.
- Step 4. Keep any spare parts for future accessory additions.

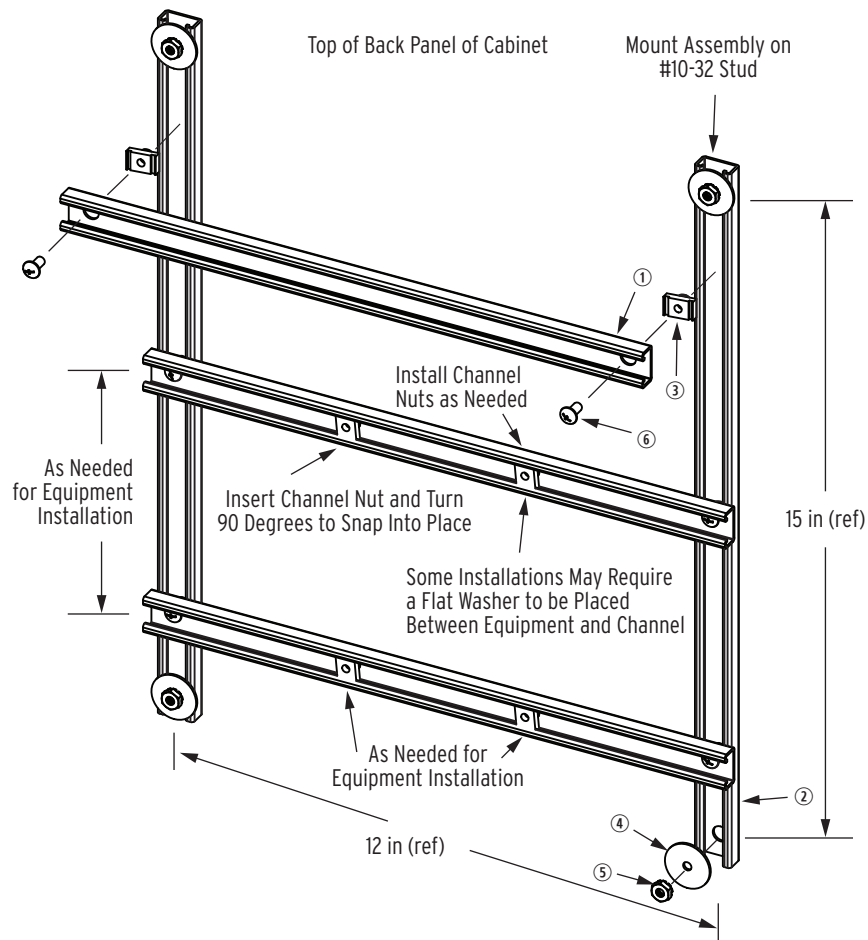

Item	Description	Quantity
1	BRACKET, C-CHANNEL, 13 IN	3
2	BRACKET, C-CHANNEL, 16 IN	2
3	CHANNEL NUT, #10-32, SPRING 13/16 CH	20
4	WASHER, FENDER, #10-1 INCH (3/16 X 1 IN)	20
5	NUT, KEP, 10-32	6
6	SCREW, PH, PHIL 10-32 X 3/8, ZINC PLATED	20
7	SCREW, PH, PHIL 10-32 X 5/8, ZINC PLATED	10
8	SCREW, PH, PHIL 10-32 X 1, ZINC PLATED	6
9	SCREW, PH, PHIL 10-32 X 1-1/4, ZINC PLATED	6

**Figure 1 Typical Installation**

# Factory Assistance

---

We appreciate your interest in SEL products and services. If you have questions or comments, please contact us at:

Schweitzer Engineering Laboratories, Inc.  
2350 NE Hopkins Court  
Pullman, WA 99163-5603 USA  
Telephone: +1.509.332.1890  
Fax: +1.509.332.7990  
Internet: [www.selinc.com](http://www.selinc.com)  
Email: [info@selinc.com](mailto:info@selinc.com)

# Notes

---

© 2011 by Schweitzer Engineering Laboratories, Inc. All rights reserved.

All brand or product names appearing in this document are the trademark or registered trademark of their respective holders. No SEL trademarks may be used without written permission. SEL products appearing in this document may be covered by US and Foreign patents.

Schweitzer Engineering Laboratories, Inc. reserves all rights and benefits afforded under federal and international copyright and patent laws in its products, including without limitation software, firmware, and documentation.

The information in this document is provided for informational use only and is subject to change without notice. Schweitzer Engineering Laboratories, Inc. has approved only the English language document.

This product is covered by the standard SEL 10-year warranty. For warranty details, visit [www.selinc.com](http://www.selinc.com) or contact your customer service representative.

## SCHWEITZER ENGINEERING LABORATORIES

2350 NE Hopkins Court • Pullman, WA 99163-5603 USA

Phone: +1.509.332.1890 • Fax: +1.509.332.7990

Internet: [www.selinc.com](http://www.selinc.com) • E-mail: [info@selinc.com](mailto:info@selinc.com)

