

# SEL-3610

## Port Server



Merge serial-based devices with Ethernet networks while providing the latest security features.

- Robust port server converts serial to Ethernet and allows for secure remote network access.
- Analog bit-based protocol conversion to Ethernet eliminates reliance on costly leased analog circuits.
- Free virtual software client creates virtual serial or Ethernet ports on Microsoft® Windows®-based PCs.
- Embedded whitelist antivirus technology reduces zero-day virus threats.



# Configure and Secure Serial and Ethernet Links

The SEL-3610 Port Server is an EIA-232, EIA-422, or EIA-485 serial-to-serial and Ethernet-to-serial cryptographic port server.

The SEL-3610 increases the number of serial ports available to communications processors and computers, and allows serial products to communicate securely through Ethernet networks.

The SEL-3610 tunnels serial data over an Ethernet connection using Secure Shell (SSH), Telnet, Modbus®, Transmission Control Protocol (TCP), or User Datagram Protocol (UDP) encapsulation. Port configurations can establish virtual bonds between one or more logical Ethernet ports and one or more physical serial ports. The SEL-3610 provides highly flexible serial and Ethernet port mappings and can filter based on which connections listen or transmit.

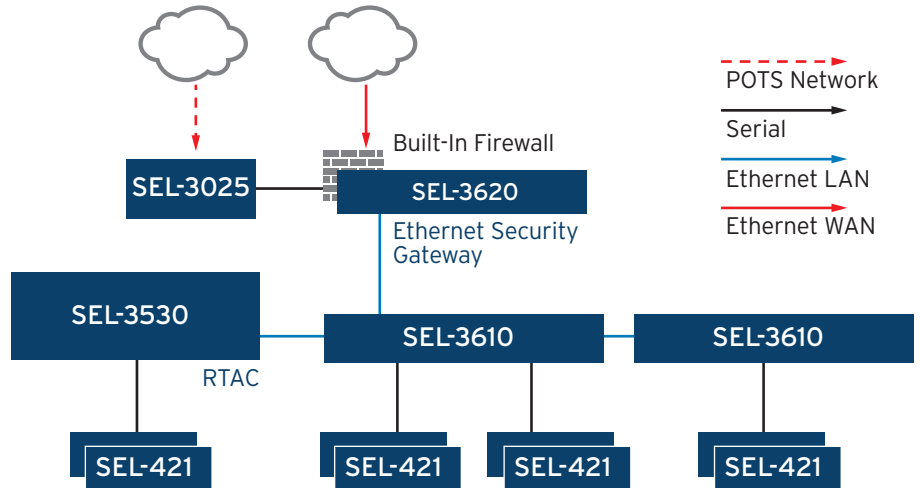

## Cybersecurity

Resist known and unknown malware attacks with exe-GUARD™ whitelist antivirus. Powerful rootkit resistance technology includes a secure kernel and process whitelisting to help stop attacks and eliminate costly patch management and antivirus signature updates.

## Serial Port Expansion

Implement the SEL-3610 to connect to rugged computers and communications processors, and gain 17 serial ports that communicate over Ethernet with SSH, Telnet, Modbus TCP, TCP, or UDP. SSH provides authenticated, transparent connections. Restrict all access to unconfigured logical and physical ports.

## Centralized Authentication

Manage user accounts and group memberships centrally using Lightweight Directory Access Protocol (LDAP)-accessible systems, such as Microsoft Active Directory® service, or by using Remote Access Dial-In User Service (RADIUS). Users need to remember only one password – their own. RADIUS functionality enables multifactor authentication technology, such as RSA tokens.

## Serial-to-Ethernet Transceiver

Expand your protocol compatibility by converting serial DNP3 and Modbus to Ethernet DNP3 TCP/UDP and Modbus TCP on the fly. Establish an Ethernet connection using SSH,

Telnet, TCP, or UDP encapsulation to create a persistent tunnel between a logical Ethernet port and a physical serial port. The device can also convert most bit-based protocols (Conitel, Tejas, Van Comm, etc.) to Ethernet to help replace analog links without disrupting existing systems.

## Highly Configurable Serial Mappings

Provide highly granular SCADA and protection network configurations with a variety of serial-to-serial, serial-to-Ethernet, and point-to-multipoint mappings. Filter based on which connections listen or transmit. For example, multiple serial ports can receive data from an Ethernet source, but the Ethernet source will only listen to responses from one serial port.

## Accurate Time Synchronization

Synchronize timing information from the SEL-3610, even if a GPS satellite signal is temporarily unavailable. Sync with local communications processors, computers, and security devices using IRIG-B for synchrophasor-accurate timing and the Network Time Protocol (NTP) over Ethernet for granular logging and event timing.

## Virtual Software Client Support

Transform unsecure serial or legacy Ethernet communications on Windows computers to cryptographically secure channels by using SEL-5827 Virtual Connect Client or SEL-5828 Virtual Port Service Software. These applications are provided free by SEL to make remote SEL-3610 ports available for existing software and terminal applications on your PC, including those using Modbus TCP/RTU. Data are secured using SSH with SEL-3610 port groups, master ports, and serial ports.



# Connections and Indicators

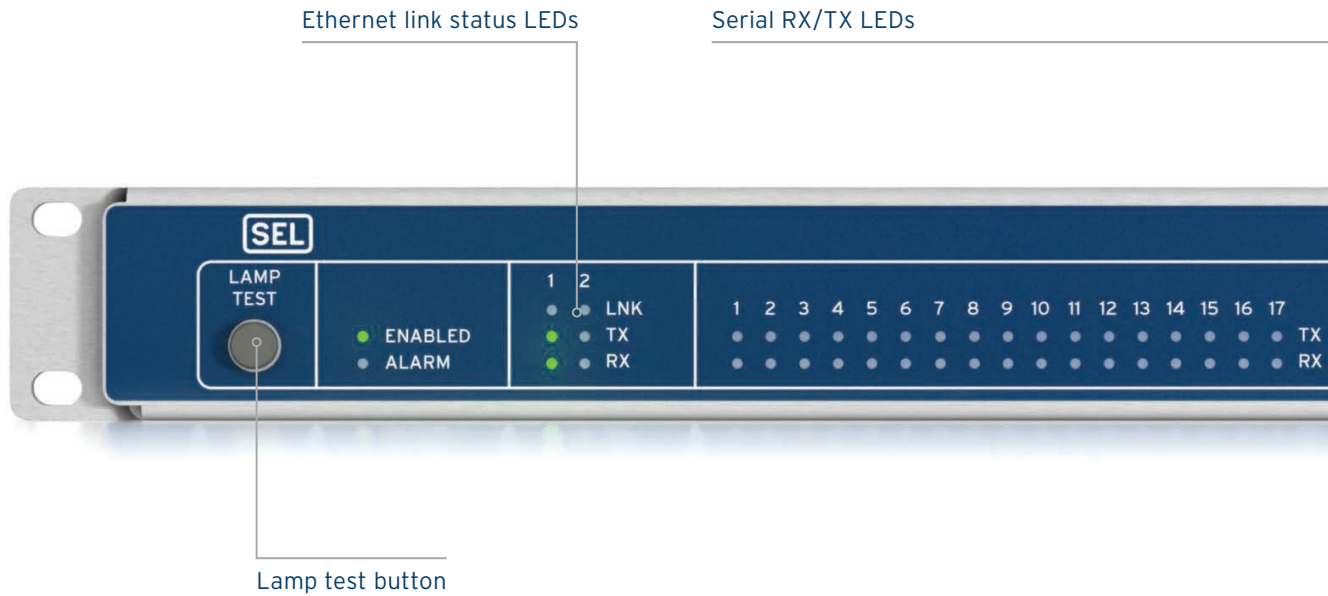

System status indication LEDs

Front Ethernet port

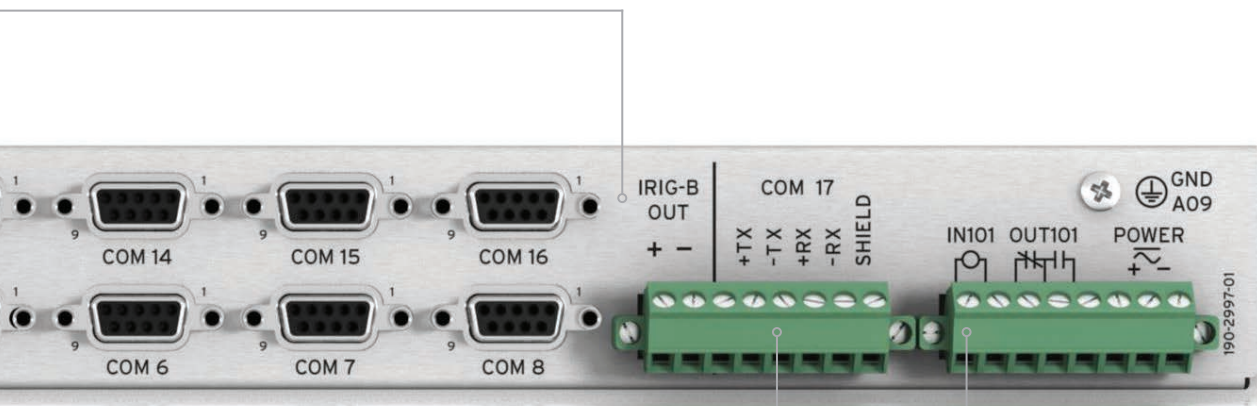

Isolated COM Port 17

Input contact

# Quickly Expand Your Serial Links in the Substation

## Master Port Functionality

A user, "Bob," connects to a master port on the SEL-3610 Port Server with his laptop via a secured modem or Ethernet wide-area network (WAN). After authenticating with his unique user name and password, Bob can choose from a list of authorized devices. Bob selects the SEL-351S Protection System, and the SEL-3610 transparently connects Bob to the relay while logging the access.

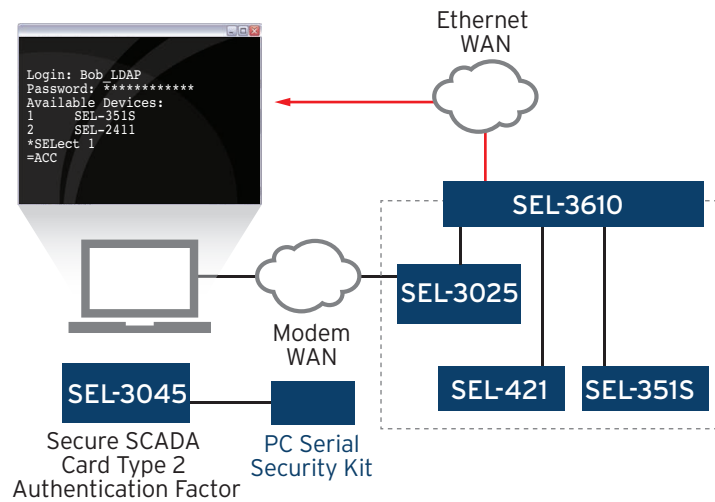

## Serial-to-Ethernet Transceiver

Establish an Ethernet connection using SSH, Telnet, TCP, or UDP encapsulation. Convert serial DNP3 and Modbus to DNP3 TCP and Modbus TCP/UDP on the fly, without upgrading relays or changing intelligent electronic device (IED) configurations.

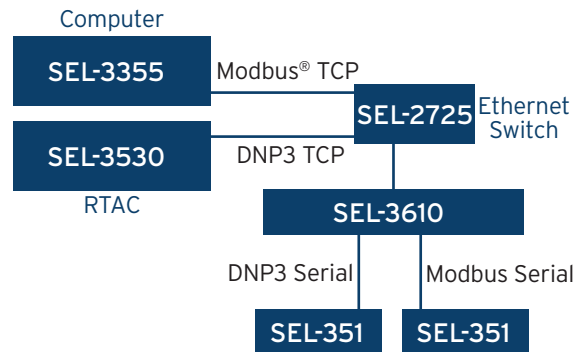

## Accurate Time Synchronization

Provide reliable time synchronization to all your protected substation devices. Distribute highly accurate time over both IRIG-B and Ethernet-based NTP. If the GPS or other time source becomes unavailable, the SEL-3610 will synchronize substation time using its own internal clock.

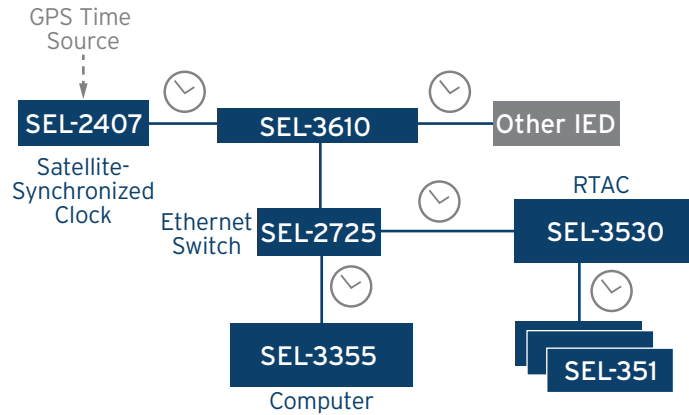

## Highly Configurable Serial Mappings

Configure the SEL-3610 with a variety of mappings, and create filters according to which connections listen or transmit. Here, the SEL-3610 is configured to allow the SEL-3355 Computer to send messages to the three SEL-421 Protection, Automation, and Control Systems, but only one of the relays is allowed to respond back to the SEL-3355 via the SEL-3610 Port Server.

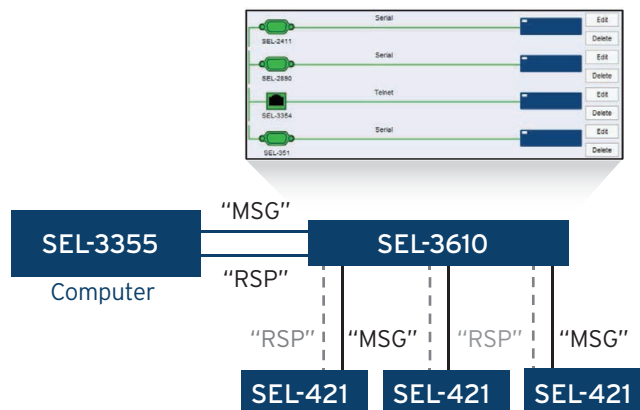

# SEL-3610 Specifications

## General

<b>Network Interfaces</b>	<b>Ports:</b> 2 rear, 1 front <b>Data Rates:</b> 10/100 Mbps <b>Front Connector:</b> RJ45 female <b>Rear Connectors:</b> RJ45 female or LC fiber (single-mode 100BASE-LX10 or multimode 100BASE-FX) <b>VLANS:</b> 1 per physical interface <b>Data Throughput:</b> 100 Mbps
<b>Serial Ports</b>	<b>Ports:</b> 17 rear <b>Type:</b> EIA-232/EIA-485 (software-selectable) <b>Data Rate:</b> 1200 to 115200 bps <b>Connector:</b> DB-9 female (Ports 1-16), isolated 8-pin (Port 17) <b>Power:</b> +5 Vdc power on Pin 1 (500 mA maximum) <b>Protocol Support:</b> Byte- and bit-based serial protocols
<b>Time Synchronization</b>	<b>NTP:</b> Server and client <b>IRIG-B Input:</b> BNC connector, IRIG B000 or B002, even or odd parity <b>IRIG-B Output:</b> BNC connector, serial ports (Pins 4 and 6), IRIG B000 even parity
<b>User Authentication</b>	<b>Local Accounts:</b> 256 maximum local accounts, requires strong passwords (8-128 characters) <b>LDAP:</b> v3, TLS-secured <b>RADIUS:</b> PAP, EAP-PEAP/MSCHAPv2, EAP-TTLS/PAP
<b>Logging and Alerting</b>	<b>SNMP Traps:</b> v1/v2c/c3 <b>Syslog:</b> UDP transport <b>RADIUS:</b> Accounting packets
<b>Physical Tamper Detection</b>	<b>Input Contact:</b> 1 (pickup/dropout depends on source)
<b>Additional Cybersecurity Controls</b>	<b>Embedded Antivirus:</b> exe-GUARD whitelisting antivirus <b>Authorization Levels:</b> Technician and Administrator <b>SSH:</b> Server and client
<b>Power Supply Options</b>	125/250 Vdc or 110/240 Vac, 50/60 Hz 85-300 Vdc or 85-264 Vac 48/125 Vdc, 120 Vac, 50/60 Hz 38.4-137.5 Vdc, 88-132 Vac 24/48 Vdc 18-60 Vdc (polarity-dependent) <30 Watts
<b>Operating Temperature</b>	-40° to +85°C (-40° to +185°F)



Making Electric Power Safer,  
More Reliable, and More Economical

Schweitzer Engineering Laboratories, Inc.  
Tel: +1.509.332.1890 | Email: info@selinc.com | Web: www.selinc.com

© 2015 by Schweitzer Engineering Laboratories, Inc.  
PF00210 • 20151013

