

University Implements Distribution Automation to Enhance System Reliability and Optimize Operations

Tyler J. Hjorth
Texas A&M University

Payal Gupta and Ashok Balasubramanian
Schweitzer Engineering Laboratories, Inc.

© 2016 IEEE. Personal use of this material is permitted. Permission from IEEE must be obtained for all other uses, in any current or future media, including reprinting/republishing this material for advertising or promotional purposes, creating new collective works, for resale or redistribution to servers or lists, or reuse of any copyrighted component of this work in other works.

This paper was presented at the 69th Annual Conference for Protective Relay Engineers and can be accessed at: <https://doi.org/10.1109/CPRE.2016.7914923>.

For the complete history of this paper, refer to the next page.

Presented at the
Power and Energy Automation Conference
Spokane, Washington
March 21–23, 2017

Previously presented at the
3rd Annual PAC World Americas Conference, August 2016

Originally presented at the
69th Annual Conference for Protective Relay Engineers, April 2016

University Implements Distribution Automation to Enhance System Reliability and Optimize Operations

Tyler J. Hjorth, *Texas A&M University*

Payal Gupta and Ashok Balasubramanian, *Schweitzer Engineering Laboratories, Inc.*

Abstract—This paper describes the objectives and operating principles of a centralized distribution automation system (DAS) developed for the underground distribution system at Texas A&M University. The DAS detects electric faults based on information from fault indicators and automatically reconfigures the distribution system topology to isolate faulted sections and restore service to the maximum number of loads possible. It is a modular, scalable system that combines fast protection with flexible automation. The communications network is based on Ethernet rings conjoined in a ladder topology that allows reliable network operation. Rapid Spanning Tree Protocol (RSTP) in the managed network switches provides faster recovery and convergence after a topology change caused by link or device failure. The multi-ring/ladder network combined with RSTP provides the DAS with a loop-free, redundant communications path with minimum network downtime. A unique Internet Protocol (IP) address range and a virtual local area network (VLAN) were assigned to groups of equipment based on their geographical locations. Internet Protocol Security (IPsec) virtual private network (VPN) tunnels were established between network gateways to provide security through authentication and encryption.

I. INTRODUCTION

Texas A&M University (TAMU) has 50 MW of power generation, together with purchased power capacity to serve 23 million gross sq. ft. of facilities and over 5,000 acres on the TAMU campus in College Station, Texas. The medium-voltage electrical service and distribution system that serves Texas A&M is owned by the university and is operated as an electric utility system in the manner by which power is distributed and utilized at the point of delivery.

The university's 12.47 kV distribution circuits consist of multiple single-conductor copper cables routed in a multiduct underground ductbank/manhole system with radial and looped circuits that are electrically separated by a normally open switch at sectionalizing switchgear, either underground or aboveground.

The conventional methods of underground fault detection and isolation were labor intensive, time consuming, expensive, and detrimental to equipment. As the distribution system becomes more complex, it becomes more difficult for human operators to perform the necessary checks, and it requires extensive action involving several operations performed in a specific sequence before electric power can be restored to de-energized loads.

A centralized distribution automation system (DAS) was developed to automate these tasks, enhance overall system reliability, and optimize operations by performing the following steps:

- Permanent fault detection and isolation
- Automatic reconfiguration for service restoration
- Substation dead-bus detection
- Automatic source transfer on loss of substation source
- System abnormal condition monitoring
- Response to multiple simultaneous faults
- Automated return-to-normal (RTN) sequence
- Communications link loss detection
- System awareness via human-machine interface (HMI)

The DAS continuously monitors the power system for any disturbance or electric fault condition based on information from fault indicators and microprocessor-based intelligent electronic devices (IEDs). On identifying a fault and its location, the DAS makes deterministic decisions and responds in less than a minute to isolate the permanent faulted section and automatically restore power to the de-energized loads.

The newly automated part of TAMU's electric power distribution system consists of three independent looped circuits with six radial feeders (A and B, C and D, and E and F), each fed from a separate substation power source. Fig. 1 shows a typical one-line diagram for a distribution feeder-looped circuit. The two radial feeders in a loop scheme are separated by a normally open load break switch, illustrated as NO. The radial feeders have multiple four-way load break switches distributed along the feeders installed in manholes and some aboveground switchgear. Though most load break switches are manually operated, some of them are automated by integrating a 24 Vdc motor operator and can be controlled remotely by the DAS.

Fault circuit indicators (FCIs) are strategically installed along each distribution feeder to detect phase and ground short-circuit faults. The FCI auxiliary output phase contact is wired to the discrete I/O device to provide fault status to the DAS over the communications network. Each pad-mount switchgear that is part of the DAS includes a four-way load break switch, FCIs, a discrete I/O device, and a managed Ethernet switch (ESW). The field devices (including substation feeder breakers, relays, and pad-mount switchgear

equipment) generate power system information and perform protection and control functionality.

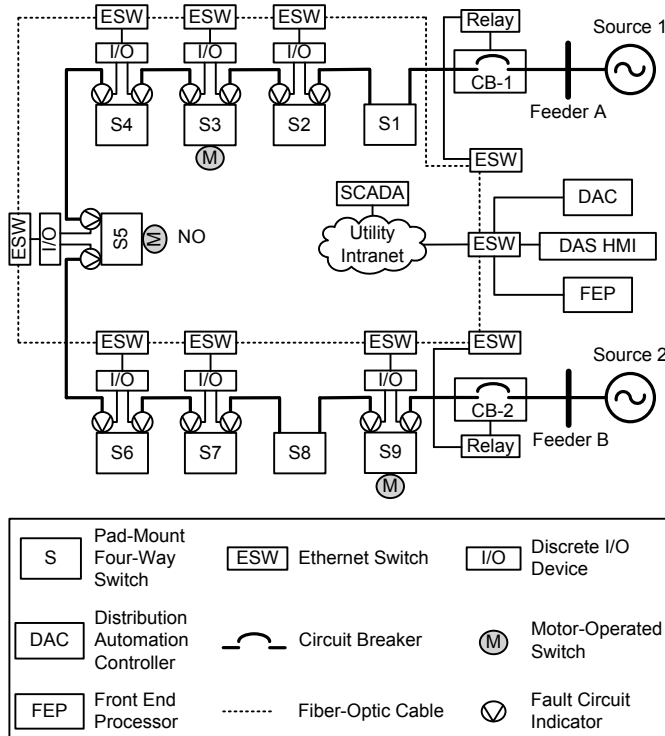

Fig. 1. Typical Automated Dual Distribution Feeder-Looped Circuit

Table I shows the equipment detail for the three looped circuits.

TABLE I
DISTRIBUTION FEEDER EQUIPMENT DETAILS

Equipment Type	A & B	C & D	E & F
Incoming feeder breakers and protective relays	2	2	2
Motor-operated switches	6	7	10
Nonmotor-operated switches	41	46	61
FCIs	29	32	40
Discrete I/O devices	13	13	17
ESWs	13	13	10

II. INTEGRATING DISTRIBUTION AUTOMATION

The TAMU distribution management project consisted of two phases. Phase I of the project was to integrate new and existing equipment into a newly designed automation system. Data from substation IEDs and controllers were made available to a supervisory control and data acquisition (SCADA) system for monitoring the entire distribution system. Phase II of the project leverages the potential of already-existing IEDs and reliable communication to develop and implement a centralized DAS for automatic network reconfiguration. The SCADA, DAS, and dispatch center can be operated from the central control room (CCR). The CCR includes devices like automation controllers, front end processors (FEPs), HMI servers, and SCADA servers.

A. FCIs

The FCI forms a crucial element in the process of determining faulted sections of the distribution system within the integrated DAS. It consists of three single-phase current sensors, one ground fault sensor (GFS), and a junction box with local visual display and an auxiliary contact output for remote indication. The four sensors and junction box are daisy-chained together with the GFS at the beginning, followed by three single-phase sensors, and lastly the junction box, as shown in Fig. 2.

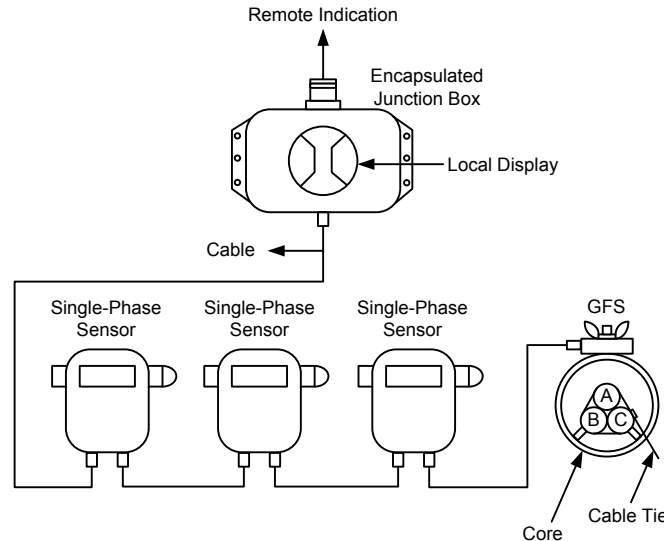

Fig. 2. Four-Sensor FCI

The FCI is inductively powered and requires a minimum continuous operating current of greater than or equal to 3 A of load current to maintain readiness to trip and automatically reset. The FCI senses the magnetic field produced by current flowing through a conductor, and it trips when any of its sensors detects current in excess of the respective sensors' nominal trip ratings and nominal delayed trip response times. Both the local display and auxiliary contact output remain latched in the tripped state until the reset occurs.

The FCI automatically resets after the phase sensor detects a nominal continuous current greater than 3 A for the reset time period (between 25 seconds and 3 minutes). The resetting of the device signifies distribution circuit restoration. The single-phase sensor and GFS have a nominal trip rating of 1200 A and 50 A, respectively. The delayed trip response time of one cycle is included to reduce nuisance tripping from temporary system transient currents.

The FCI has an inrush restraint feature to prevent tripping from transformer inrush and cold load pickup currents when the distribution system is being energized from a de-energized state and during a reclosing sequence. The inrush restraint feature is loss-of-current activated, and it activates when the phase sensor detects a loss of current below the inrush restraint activation level of 0.5 A for the nominal response time of 300 milliseconds.

B. Data Acquisition

Substation IEDs provide power system information along with performing protection and control functionality. Rugged automation controllers (RACs) used at different levels in the communications hierarchy provide data concentration, protocol conversion, and remote engineering access. Custom user logic at the RAC provides data conditioning of analog and digital data.

Substation RACs located in the switchgear collect analog and discrete data and send control commands to the substation IEDs. The RAC is also programmed to have remote engineering access and to collect oscillography event reports automatically from IEDs. FEPs located at the CCR collect data from seventeen RACs and provide metering and status information to the SCADA system using DNP3 protocol for HMI visualization and data archiving. Redundant FEPs improve availability by providing a primary and secondary connection to the SCADA system.

The distribution automation controller (DAC) collects important analog and digital information required for the DAS from substation IEDs via substation RACs. Discrete I/O devices wired to FCIs communicate fault information using DNP3 Transmission Control Protocol/Internet Protocol (TCP/IP) to the DAC. The DAC uses the information to monitor the health of the system, such as system topology, feeder loading, and voltage levels; it also provides system-wide awareness and control for a large group of feeders. The data collected from the field through RACs and discrete I/Os were used in the control functions developed using an IEC 61131 logic engine for automatic reconfiguration algorithms to improve system reliability.

The DAC programming is modular and simple with built-in drag-and-drop function blocks to automate real-world electrical objects, such as reclosers, circuit breakers, disconnect switches, transformers, circuits, buses, and lines. Each function block has several inputs to set operating constraints, such as capacity, normal state, and abnormal condition, and is linked to real-time IED parameters, such as voltage, currents, status, and faults. The function block outputs are linked to IED controls, such as close and open commands. Using these well-defined function blocks, a model was built representing the actual TAMU distribution system topology.

The DAS HMI controller at the CCR provides the HMI screens used for monitoring and controlling the DAS. It communicates with the DAC using DNP3 protocol. The diagnostic HMI displays the DAS status, fault location, IED data, switch position, system events, and alarms; and it provides operator control of the DAS. The HMI has web-based access for multiple users to access the HMI simultaneously over the network.

Fig. 3 illustrates the system data acquisition flow.

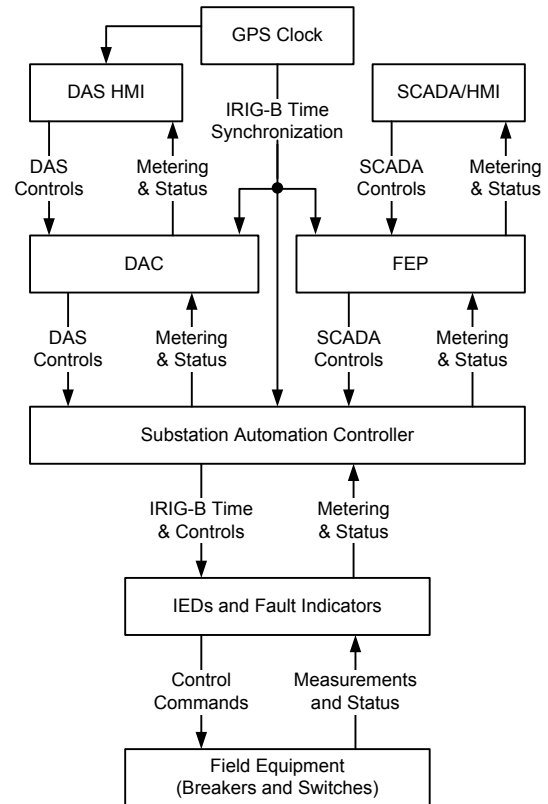

Fig. 3. Data Acquisition Flow Diagram

C. Network Design Consideration

Since the DAS is a communications-assisted control scheme, it requires a robust high-speed communications system with self-healing capability that provides fast recovery upon network failure. The DAS communications network was based on a fiber-optic backbone to ensure excellent electrical isolation and to enable long-distance communication. The DAS Ethernet network includes multiple managed ESWs. The ESWs use rapid spanning tree protocol (RSTP) to determine a loop-free redundant path to end devices. Without RSTP, a ring network would cause Ethernet frames to circulate endlessly through the network, which would be detrimental to the network and affect service availability.

While the details of RSTP operation and ESW network management are beyond the scope of this paper, a few key characteristics are described here. The root bridge is the logical center of the network. The network always has exactly one root bridge at any given time. Every ESW has an identifying number assigned to it, referred to as a bridge ID. It is a combination of bridge priority and the media access control address of the ESW. The ESW with the lowest bridge ID is selected as the root bridge via RSTP. Additionally, each port on the switch was assigned a port state and a port role.

The three possible operational port states are discarding, learning, and forwarding. The five port roles include root, designated, alternate, backup, and disabled.

RSTP establishes dynamic rules within network switches on how data flows between devices, both during normal network configuration and during a communications interruption. A communications interruption can be caused by a switch failure, a port failure, or a cable failure. RSTP identifies the failure and forwards the data packets through a pre-identified alternate path.

A ring architecture tends to be the most popular for inherent redundancy and reduced cable cost. However, the performance of the ring network depends on the number of switches in the ring. The greater the number of nodes, the greater the time required for reconfiguration and restoration of the network [1].

For this application, due to the large number of devices and therefore the number of ESWs used, a single-ring architecture would not have given the required network performance. A multi-ring network conjoined in a ladder topology was used to limit the number of switches in a single ring. The multi-ring/ladder network constitutes five individual rings and a total of 39 ESWs, as shown in Fig. 4. Each individual ring constitutes communication with IEDs for a single looped circuit with two radial feeders.

ESW1, ESW2, and ESW3 are part of Ring #1, where the CCR devices are connected. ESW1 and ESW2 are part of all the rings in the network and are thus designated as root bridge and backup root bridge, respectively. ESW4 to ESW16 form Ring #2 with all field communications devices for Feeders A and B. Similarly, ESW17 to ESW29 form Ring #3 with all field communications devices for Feeders C and D. ESW30 to ESW36 form Ring #4, and ESW37 to ESW39 (along with ESW30) form Ring #5 with all field communications devices for Feeders E and F.

Other DAS network devices, such as workstation computers, simulator, and other small substation controllers, are connected radially to the ESWs in Ring #1.

All communications devices in a feeder circuit have a unique IP address range to form a subnetwork and are also assigned a unique VLAN identifier. Data traffic between different feeder circuits is segregated based on VLAN identifiers. Data segregation offers improved network performance by directing traffic from a particular feeder subnetwork to the CCR subnetwork (SCADA and DAS) only. This implementation controls the flow of packets in the network and prevents data packets from flowing to unauthorized end nodes.

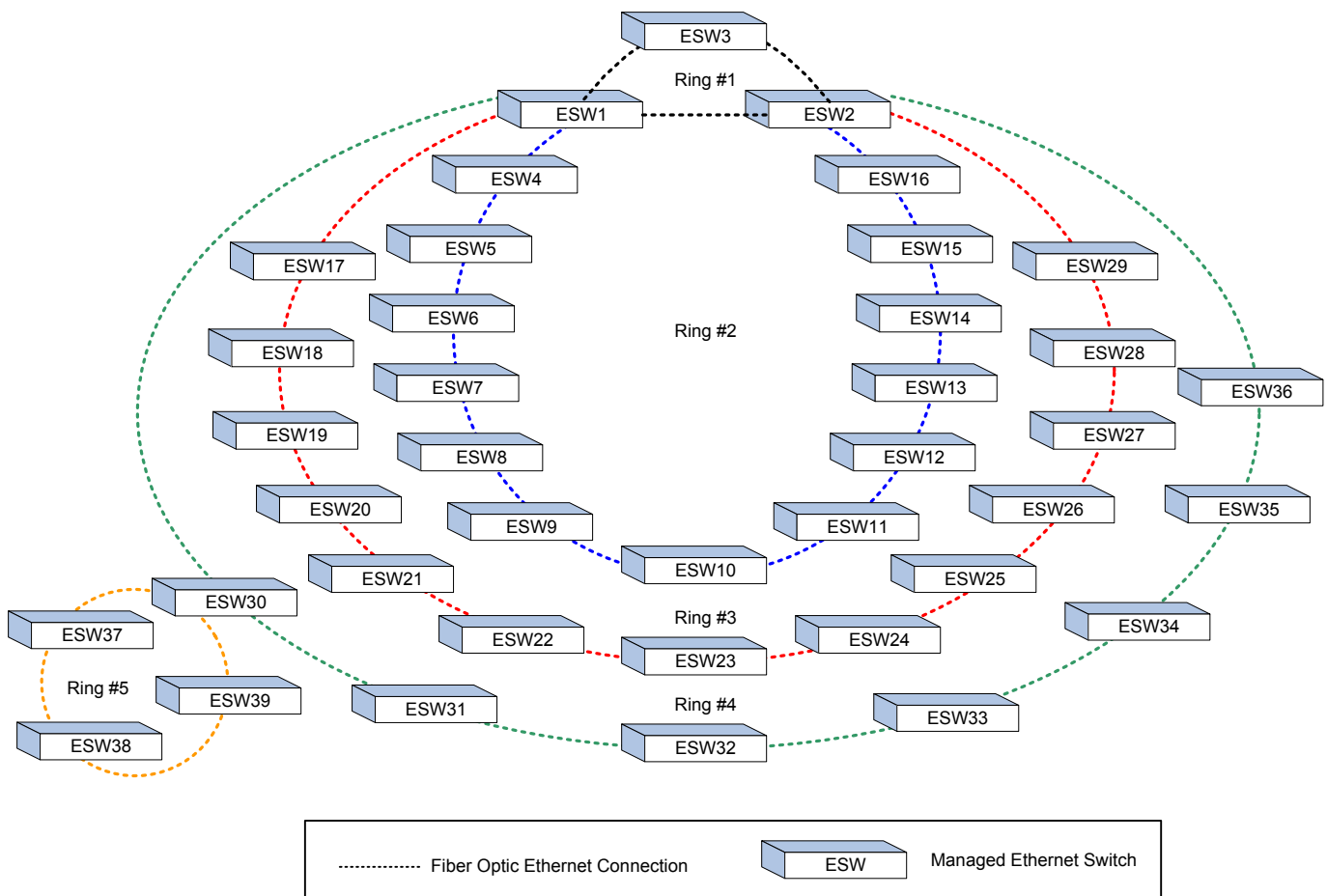

Fig. 4. Ethernet Network Topology

D. Network Security

Data required for operation of the DAS are communicated between controllers and field equipment through several ESWs that are located in unsupervised locations. For example, referencing Fig. 4, data traffic from an IED connected to ESW9 in Feeder A to the controller connected to ESW3 in the CCR has to flow through six ESWs. These ESWs are installed in unsupervised underground pad-mount gears and constitute the untrusted part of the DAS network. For untrusted network segments, using a virtual private network (VPN) provides confidentiality, authentication, and integrity of the transmitted

data. The TAMU DAS uses a combination of VLAN and VPN technologies to create a tiered system of network security [2].

Ethernet security gateways (SG) are installed at each feeder circuit and the CCR location. The SG encrypt and secure all communication across an untrusted network by establishing an Internet Protocol Security (IPsec) tunnel between a unicast source IP address and a unicast destination IP address located at two geographically distant locations, as shown in Fig. 5. The IPsec supports very strong cryptographic authentication and encryption, thus protecting traffic privacy. Multilevel passwords and role-based user access configured in the devices protect them from unauthorized access.

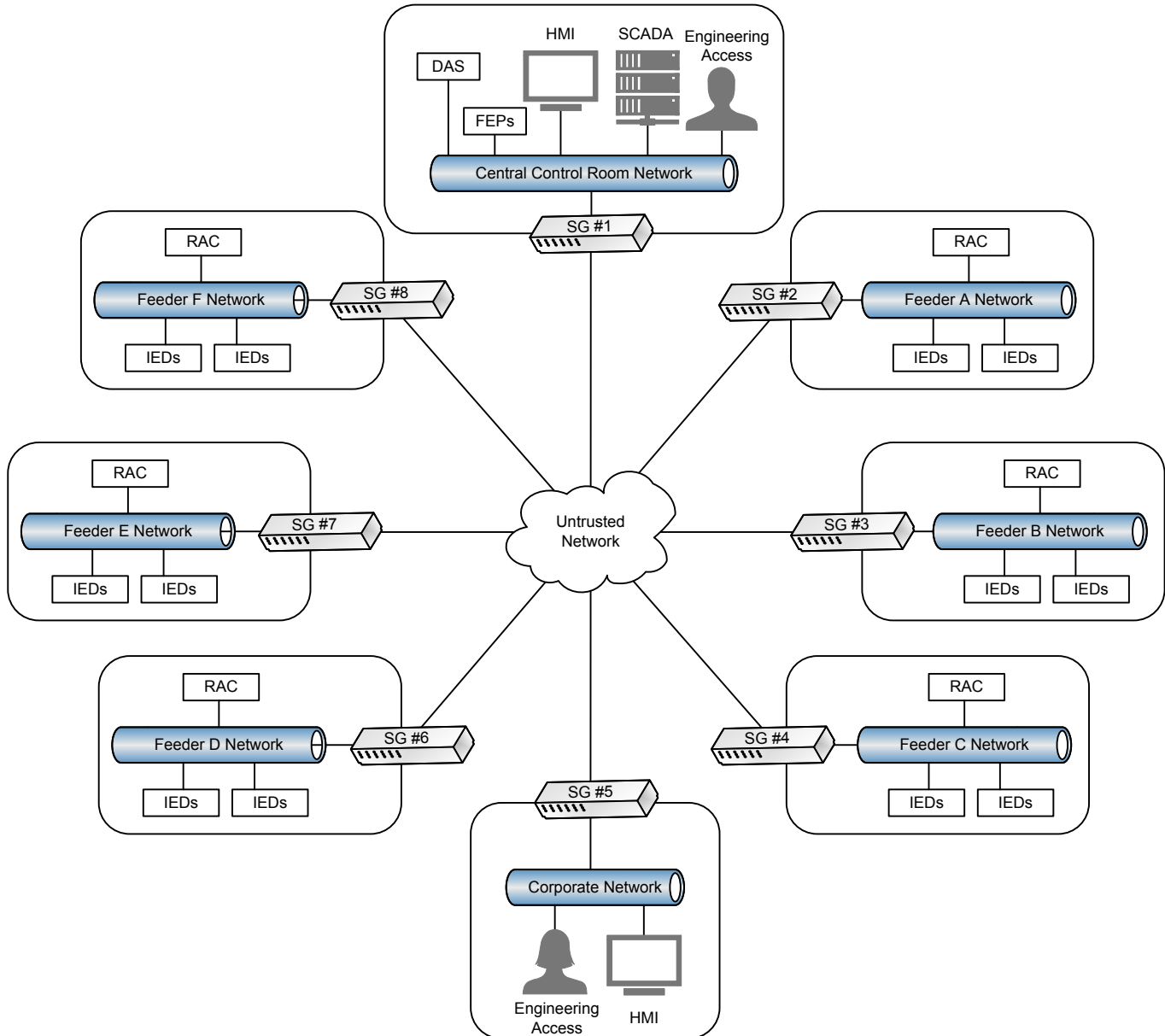

Fig. 5 IPsec VPN Tunnel Between the DAS Subnetworks

E. Time Synchronization

A satellite-synchronized clock is used to provide system-wide precise time synchronization with an accuracy of ± 100 nanoseconds. The global positioning system (GPS) clock distributes IRIG-B time to automation controllers, which in turn distribute the time to individual IEDs using demodulated IRIG-B time source inputs over serial connections.

Time-synchronized IEDs offer recording capabilities in the form of high-resolution sequence-of-event and oscillography event reports with precise time tags. Time synchronization is highly valuable when analyzing and coordinating event reports from different relays within the substation, especially from relays located at different substations that are synchronized to a common time source. This feature is extremely useful to understand pre- and post-fault system behavior and determine root cause of an event.

III. DAS THEORY OF OPERATION

The fault isolation and automatic restoration capabilities of the DAS offer safe and reliable delivery of electric power. All three feeder-looped circuits are evaluated independently by the DAS. Multiple simultaneous faults occurring at different locations in the same feeder-looped circuit or on a different feeder-looped circuit are all considered by the DAS. It takes action for each of the permanent faults on the distribution system.

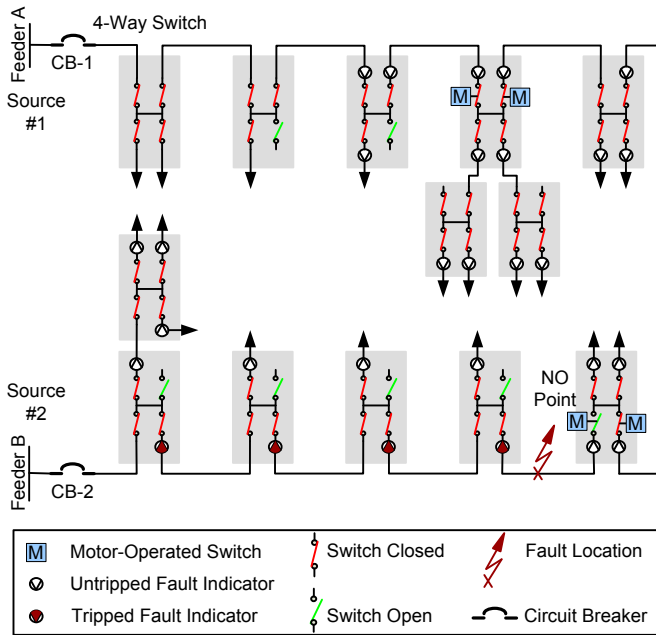

Fig. 6. Distribution System One-Line Diagram for Feeders A and B

Fig. 6 shows a typical simplified one-line diagram for Feeders A and B. There are two sources, each with an incoming feeder breaker. The loads are supplied either by a preferred source or by the alternate source, which supplies power to load when the normal source is unavailable. Each of the switches is defined as normally closed or normally open in the distribution system topology. Motor-operated switches that can be remotely controlled by the DAS are identified. The

FCIs are strategically placed, and their locations are identified along the distribution feeder.

A. Automatic Reconfiguration Sequence (ARS)

When operational, the DAS is always in one of three system states: initialize, unarmed, and armed. Reference [3] describes the functionality of the DAS in each of the system states and the steps involved in the ARS. The sections below further discuss the ARS that the DAS executes for fault identification, isolation, and power restoration.

The DAS scheme can be enabled or disabled from the HMI by the operator. The DAS can execute the ARS and take appropriate actions only when it is enabled and in the armed state. If unarmed, the DAS does not take any action; however, it still polls data from IEDs for monitoring purposes. Fig. 7 illustrates the sequence executed when a new event is detected on a feeder.

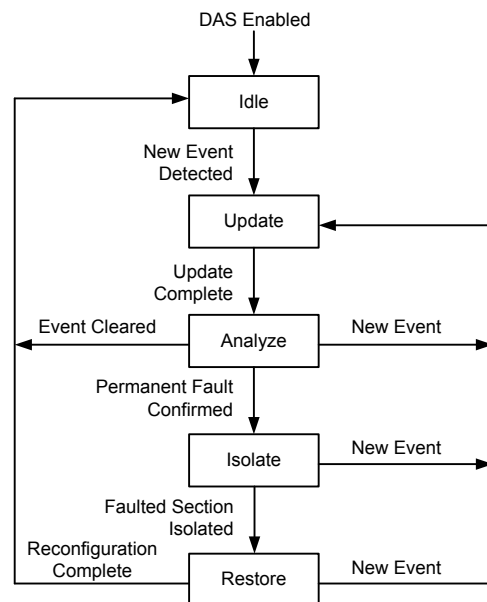

Fig. 7. ARS When New Event Is Detected [3]

The DAS is in the idle step when armed. In the idle step, it constantly monitors the power system for any electric faults along the distribution feeders. When an event occurs, one or more FCIs pick up and report the fault. The DAS on fault detection executes the update step where it sends an integrity poll to all the devices on the event feeder and adjacent feeders to update itself with the up-to-date information about the distribution system and also to check the health of the devices involved.

After the update step is complete, the analyze step is executed. The DAS confirms a permanent fault when a breaker trip and lockout condition is detected at the incoming feeder breakers and a dead-bus condition persists after a configurable confirmation delay time has elapsed. Once the event is confirmed, the DAS executes an algorithm to find an acceptable solution that re-energizes maximum load while staying within the loading constraints of the power system. It identifies all closed switches that could potentially be opened to sectionalize the faulted zone and all viable open switches that could potentially be closed to re-energize all or part of the

load in question. The DAS iterates through the combinations of open and close possibilities and selects the solution that results in the least amount of load left de-energized. The DAS algorithm evaluates all the alternative feed options based on voltage health, source capacity, and abnormal conditions on the circuit.

To avoid any undesired operation, the DAS also supervises certain system conditions that it considers abnormal, including switchgear local tag, supervisory control disabled, device failure, or communications failure. If an abnormal condition is present on any switching device associated with a feeder, the entire feeder is considered to have an abnormal condition. The DAS neither responds to events on the abnormal feeder nor considers it as a valid alternate feed [4]. On an abnormal condition, the sequence aborts and returns to the idle step. The DAS asserts an alarm displayed on the HMI, making the operator aware of the condition.

The isolate step is executed after the analyze step, where the DAS isolates the faulted section of the feeder by sending an open command to the motor-operated switches adjacent to the faulted section. It verifies the state change of the switch's 89A contact to confirm that the action of isolating the faulted section is complete before proceeding to the restore step. In the restore step, the DAS restores the nonfaulted sections of the feeder from the normal source and the alternative source by sending close commands to normally open motor-operated switches and the feeder breakers. Once reconfiguration is complete, the DAS goes back to the idle step and waits for subsequent events that require reconfiguration actions.

B. DAS Ancillary Functionality

The automatic source transfer functionality is enabled in the DAS to further improve the reliability of the system. The DAS monitors the voltage and health of the two sources in a feeder-looped circuit. If one of the sources becomes unavailable, the DAS evaluates the health and capacity limit of the second source to verify its availability as an alternate source without any overload condition. It sends an open command to the unavailable source circuit breaker. It then sends a close command to the normally open switch to transfer the entire feeder circuit to the available alternate source.

The DAS also provides automated RTN functionality that initiates a sequence of operation to return the distribution network to its normal configuration after temporary reconfiguration during maintenance or after a fault. The RTN scheme can be initiated by the single click of a button on the HMI. Reconfiguration may include several switch operations, which are executed in a specific sequence. Additionally, the DAS performs validation checks to ensure system limits are not exceeded and safety is not compromised.

Along with the switch 89A contact status and FCI auxiliary contact status, the discrete I/O device also provides other essential pad-mount gear indications, such as a water level alarm, sump pump start/stop status, 120 V service monitor, and local/remote status to the DAS for its consideration or for monitoring purposes. For personnel safety, the 43 local/remote

selection switch is provided in the pad-mount gear. The local control is applied when the field crew is working with the equipment in the pad-mount gear. The local indication is sent to the DAS to disable any remote action by the DAS, such as opening and closing of switches. Some of the contact statuses (like the switch's 89A contact status and local/remote status) that are not available from the field equipment have to be manually entered by the operator from the HMI screen so as to update the DAS with the current status information.

IV. TESTING AND IMPLEMENTATION

Factory acceptance testing (FAT) was a very crucial step in validating the design, logic, and performance of the DAS. A thorough FAT helped reduce the time spent performing on-site verification. The TAMU DAS test simulator simulates information from the field devices in the distribution system. The simulator model is built with modules, imitating electrical devices, interconnected to resemble the actual TAMU distribution system. The simulator generates field data pertaining to real power system components like substation source, breakers, switches, fault indicators, and relays. The simulator data are then fed into the DAC for testing. The simulator HMI is used to initiate system faults and allows visual monitoring of the simulated power system state to verify the DAS actions by validating the correct operation of the scheme during each test scenario.

The simulator computer is connected to the same network as the DAC and DAS HMI controller for testing purposes, as shown in Fig. 8. A test plan was created which lists many fault scenarios to be verified, along with the results that are expected from the DAS. Predetermined fault scenarios are then simulated, and test results are documented and validated. The test simulator was used extensively during FAT and will be used for future maintenance, training, and testing.

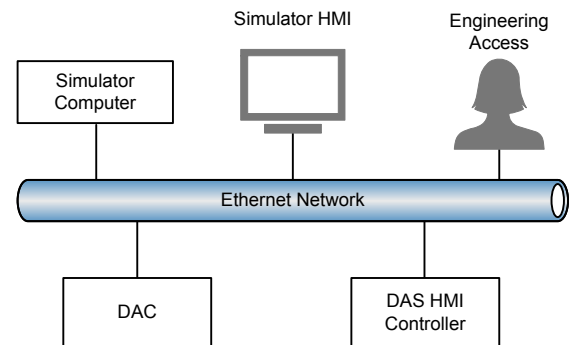

Fig. 8. DAS Test Simulator Setup

At the time of this paper's publication, the DAS was undergoing on-site commissioning. A comprehensive checklist was created prior to commissioning to systematically check each component of the DAS. The document was shared with groups involved in the process of commissioning, including engineering, field services, operations, and communications. This helped gain understanding of specific methods of testing and the reasoning behind the process.

V. CONCLUSION

A centralized DAS was developed and implemented for the underground distribution system at TAMU to enhance system reliability and optimize operations. The DAS uses information from IEDs and FCIs connected via high-speed communication to identify electric fault conditions. It determines the fault location, isolates the faulted section, and automatically restores power to unaffected de-energized loads from the normal source or alternative source, if available. The DAS is a scalable and flexible solution for easy future expansions. It has helped maximize efficiency of distribution system assets while dramatically reducing outage time and operating costs.

VI. REFERENCES

- [1] N. Seeley and K. Concienne, "Making Peace With Communications Networks: What Power Engineers Need to Know About Modern and Future Network Communication for Plants and Substations," proceedings of the 58th Annual Petroleum and Chemical Industry Conference, Toronto, Canada, September 2011.
- [2] G. Leischner and C. Tews, "Security Through VLAN Segmentation: Isolating and Securing Critical Assets Without Loss of Usability," proceedings of the 9th Annual Western Power Delivery Automation Conference, Spokane, Washington, April 2007.
- [3] D. Gomes, R. Colunga, P. Gupta, and A. Balasubramanian, "Distribution Automation Case Study: Rapid Fault Detection, Isolation, and Power Restoration for a Reliable Underground Distribution System," proceedings of the 68th Annual Conference for Protective Relay Engineers, College Station, TX, April 2015.
- [4] R. Greer, W. Allen, J. Schnegg, and A. Dulmage, "Distribution Automation Systems With Advanced Features," proceedings of the Rural Electric Power Conference, Chattanooga, TN, April 2011.

VII. BIOGRAPHIES

Tyler J. Hjorth, P.E., graduated with his B.S.E.E. from Texas A&M University (TAMU) in 1991 and has over twenty years of experience in the design, operation, and maintenance of electrical distribution systems in the chemical and nuclear industries. He returned to TAMU in 2013 to serve as manager of Electrical Services, where he is responsible for the campus high- and medium-voltage electrical systems, emergency power systems, and the utility plant's electrical and control systems.

Payal Gupta received her B.S. in electrical engineering from the National Institute of Technology, India, in 2007 and her M.S. in electrical engineering from the University of Houston in 2011. She is presently working as an automation engineer at Schweitzer Engineering Laboratories, Inc. in Houston, Texas. She has been involved in the design, engineering, and implementation of power management systems and distribution automation systems for industrial projects and electric utilities.

Ashok Balasubramanian, P.E., received his B.E. degree in electrical and electronics engineering from the University of Madras, India, in 2004 and an M.S. in power systems from the University of Alaska, Fairbanks, in 2006. Upon graduation, he worked in the process automation industry in Alaska for more than three years, where he worked on process automation projects and gained experience integrating programmable logic controllers with microprocessor-based protective relays. He joined Schweitzer Engineering Laboratories, Inc. in January 2010 and is currently an automation engineer in the engineering services division.