

SEL-487E

Transformer Protection Relay



High-speed transformer differential protection for up to six terminals

- Minimize damage and limit expensive repairs to transformers with advanced differential protection and three restricted earth fault (REF) elements.
- Consolidate protection schemes using a combination of differential, distance, and overcurrent elements suitable for transformer, bus, line, and feeder protection.
- Simplify engineering and reduce maintenance costs by using a single device for pad-mounted switchgear applications.
- Benefit from comprehensive substation asset management with through-fault, thermal, and circuit breaker monitoring.
- Transform and simplify the way you modernize your substation with SEL Time-Domain Link (TiDL®) or Sampled Values (SV) technologies.



Functional Overview

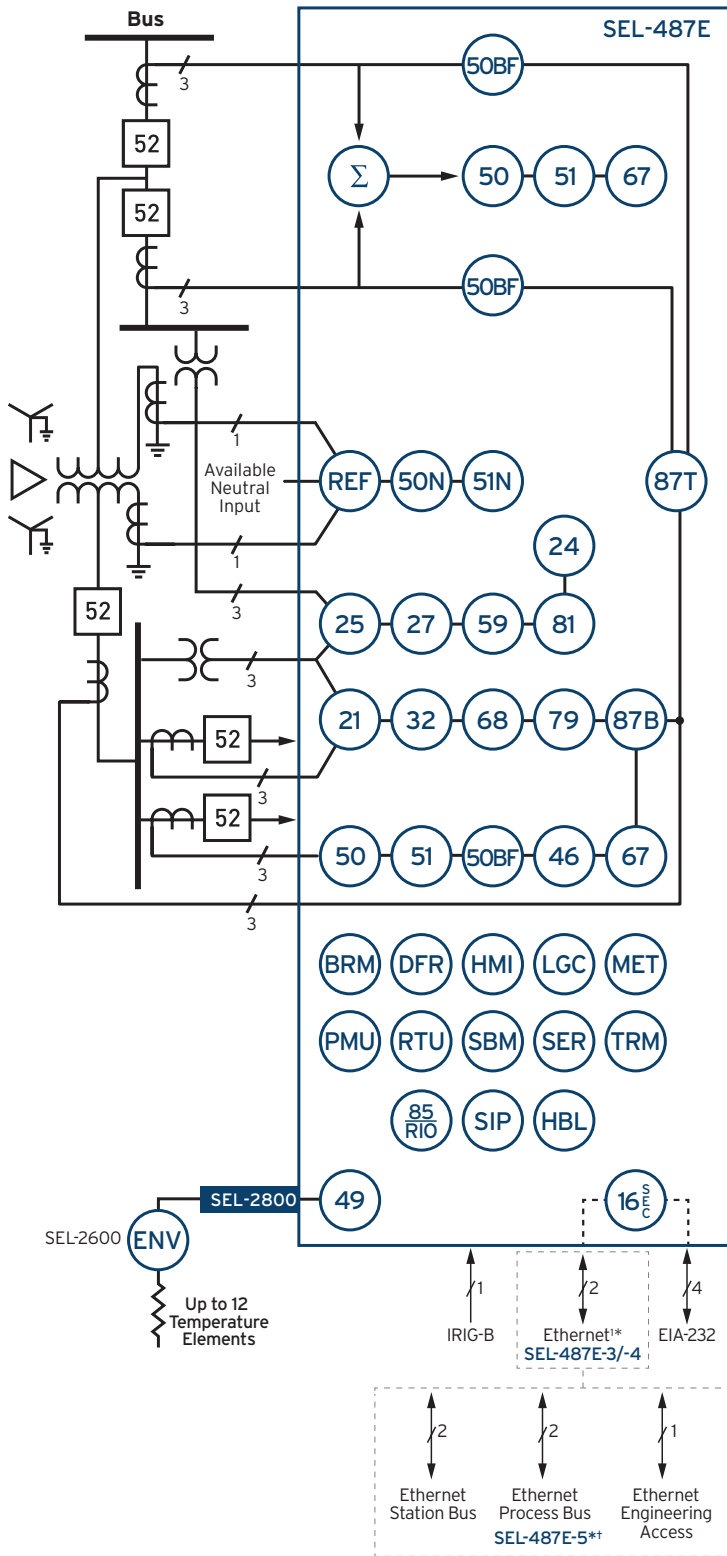

ANSI Number/Acronyms and Functions

16 SEC	Access Security (Serial, Ethernet)
21*	Phase and Ground Distance
24	Volts/Hertz
25	Synchronism Check
27	Undervoltage
32	Directional Power
46	Current Unbalance
49	IEEE C59.71- and IEC 60255-Compliant Thermal Model
50BF	Dual Breaker Failure Overcurrent
50N	Neutral Overcurrent
50	Overcurrent (Phase, Zero Sequence, Neg. Seq.)
51N	Neutral Time Overcurrent
51	Time Overcurrent (Phase, Zero Sequence, Neg. Seq.)
59	Overvoltage
67	Directional Overcurrent (Phase, Zero Sequence, Neg. Seq.)
68*	Out-of-Step Block
79*	Autoreclosing
81	Over-/Underfrequency
85 RIO	SEL MIRRORRED BITS® Communications
87T	Transformer Differential (Unrestrained, Restrained, Neg. Seq.)
87B*	Bus Differential (Restrained)

Additional Functions

BRM	Breaker Wear Monitor
DFR	Event Reports
ENV	SEL-2600 RTD Module*
HBL	Harmonic Blocking
HMI	Operator Interface
LDP	Load Data Profiling
LGC	SELogic® Control Equations
MET	High-Accuracy Metering
PMU	Synchrophasors
REF	Restricted Earth Fault
RTU	Remote Terminal Unit
SBM	Station Battery Monitor
SER	Sequential Events Recorder
SIP	Software-Invertible Polarities
SV	IEC 61850-9-2 Sampled Values Technology*†
TiDL	Time-Domain Link Technology*†
TRM	Transformer Monitor

†Copper or fiber-optic *Optional feature

†TiDL and SV relays receive current and voltage values from remote merging units.

Key Features

Multiwinding Protection

Configure the SEL-487E Transformer Protection Relay for differential protection in transformer applications using up to six restraint currents. This includes single transformers with tertiary windings. Three independent REF elements offer protection for grounded-wye windings. You can invert individual or grouped CT or PT polarities to account for field wiring or protection zone changes.

High-Speed, Adaptive Differential Protection

Implement a two-stage slope that automatically adapts to internal or external fault conditions, even with CT saturation and heavily distorted waveforms, for fast, sensitive, dependable, and secure differential protection. The adaptive differential element responds to internal fault conditions in less than 1.5 cycles. The SEL-487E includes two differential elements: one intended for protecting transformers and the other intended for protecting busbar applications.

Diverse Applications

Simultaneously protect transformers, buses, lines, and feeders in centralized protection applications. Protect large transformers and autotransformers with breaker-and-a-half high- and low-side connections. You can configure the SEL-487E for a typical two-winding transformer application and use the remaining three-phase current inputs for feeder or line backup protection.

Sensitive Turn-to-Turn Fault Detection

The patented negative-sequence differential element detects turn-to-turn faults involving as little as 2 percent of the total winding, helping avoid catastrophic transformer failure.

Configurable Distance Protection

Apply up to four zones of phase and ground distance protection using mho or quadrilateral characteristics. The SEL-487E distance elements can be applied as primary transmission line or backup transformer protection.

Dependable Backup Protection

Provide backup protection with phase, negative-sequence, and zero-sequence overcurrent elements and 20 configurable time overcurrent elements. By setting up breaker failure protection with subsidence detection, you can rapidly detect breaker failure and minimize system coordination times.

Generator Step-Up Transformer Protection

Protect generator step-up (GSU) transformers with built-in temperature measurement (requires the SEL-2600 RTD Module) that monitors generator and transformer winding temperatures simultaneously. In addition, the volts/hertz element provides overexcitation protection for loaded and unloaded generator operating conditions. By setting the directional power elements to detect forward and reverse power flow conditions, you can monitor and protect the GSU transformer in prime-power, standby, base-load, and peak-shaving applications. Built-in synchronism-check elements verify the generator breaker synchronization.

Advanced Asset Monitoring

Track transformer wear with through-fault and thermal monitoring. Advanced breaker monitoring reduces inefficient and costly breaker maintenance. You can also monitor substation dc power systems for out-of-tolerance voltage levels or excessive voltage ripple.

Station Phasor Measurement Unit (PMU)

Improve power quality with IEEE C37.118 synchrophasors from all 24 analog channels (6 voltage and 18 current sources) in your relay. Using synchrophasors over serial or Ethernet communications, you can easily detect reactive loop flows, turn state estimation into state measurement, and provide early warning of potential system instability. Real-time control is possible by receiving synchrophasor messages from two PMUs, and you can take action based on time-synchronized local and remote measurements.

Digital Secondary System Technologies

Modernize your substation by applying SEL TiDL or SEL SV technology. Both of these digital secondary system solutions replace copper wires with fiber-optic cables to increase safety, reduce costs associated with using copper wires, and limit the impact of electromagnetic interference.

TiDL is a simple and secure point-to-point solution that is easy to implement, with no external time source or network engineering required. SEL-TMU TiDL Merging Units placed in the yard digitize signals and transmit them over fiber-optic cables to the SEL-487E-5 TiDL relay in the control house.

SEL SV combines protection in the merging unit with the flexibility of IEC 61850-9-2 to increase power system reliability. SEL SV merging units (or other IEC 61850-9-2 SV-compliant units) digitize signals and transmit them via Ethernet over fiber-optic cables to SEL SV relays in the control house.

Product Overview

EIA-232 front serial port is quick and convenient for system setup and local access.

Easy-to-use keypad aids simple navigation.

Front-panel LEDs indicate custom alarms and provide fast and simple information to assist dispatchers and line crews with rapid power restoration.

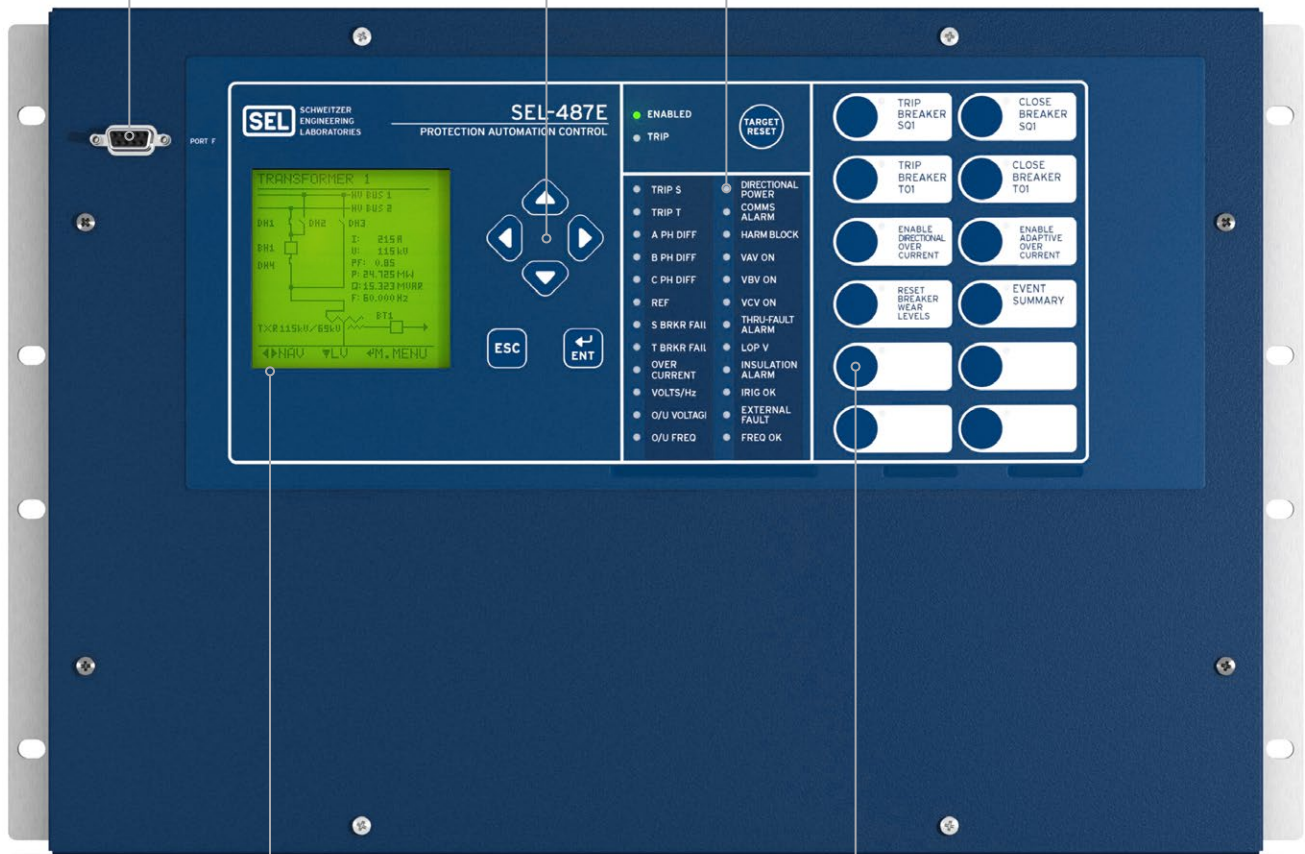

LCD allows you to control and view the status of disconnects and breakers.

Programmable operator pushbuttons with user-configurable labels allow front-panel customization.

Communications protocols include FTP, Telnet, synchrophasors, DNP3 LAN/WAN, the Parallel Redundancy Protocol (PRP), High-Availability Seamless Redundancy (HSR), the IEEE 1588 Precision Time Protocol Version 2 (PTPv2),** and IEC 61850 Edition 2.1.*

Choose from a horizontal or vertical (5U only), panel-mount or rack-mount chassis and different size options.

Use one front and three rear EIA-232 ports for MIRRORRED BITS communications, DNP3, SCADA, and engineering access.

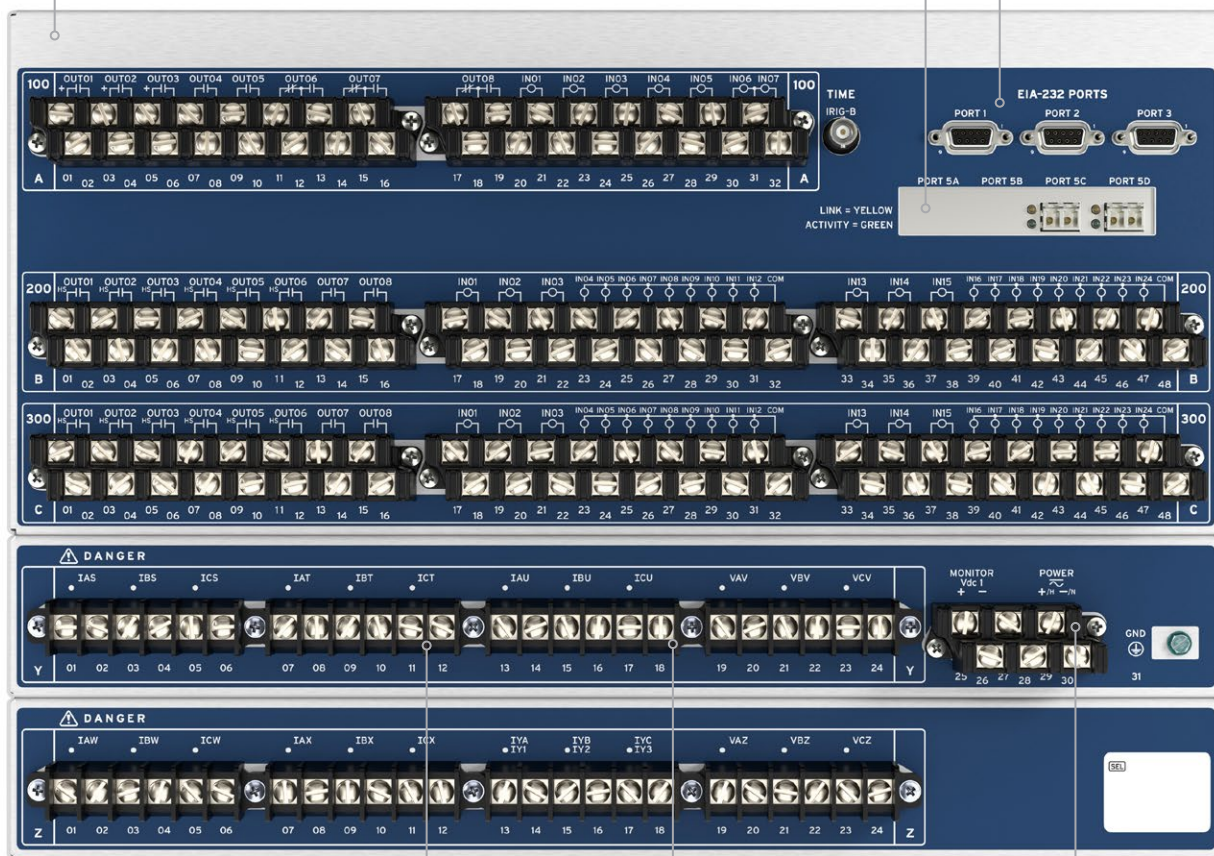

The 18 current and 6 voltage channels support differential protection for up to 6 three-phase terminals, 3 independent REF elements, and voltage elements.

Choose from power supply options such as 24–48 Vdc; 48–125 Vdc or 110–120 Vac; or 125–250 Vdc or 110–240 Vac.

Choose six voltage inputs in either standard terminal blocks, a Connectorized® hardware configuration, or an LEA hardware configuration.

*Optional feature.

**For PTPv2 implementation, Ports 5A and 5B must be ordered as an option.

Applications

Multiwinding Differential Transformer Protection

Provide current differential protection for up to six 3-phase terminals with an adaptive-slope percentage restraint for transformers at power plants, transmission substations, distribution substations, and industrial plants. The adaptive differential element includes two slope settings. During normal operating conditions, Slope 1 provides a fast response to internal faults. For external faults, the relay switches from Slope 1 to Slope 2 to provide a high-security mode and avoid misoperation from CT saturation. When the operating quantities exceed the differential slope characteristic and fall in the operate region, the filtered differential element asserts. This application shows three-winding transformer differential protection and overcurrent backup protection for two feeders.

Combine harmonic-blocking and -restraint functions in parallel to provide secure operation and optimum operating speed during inrush conditions. Second- and fourth-harmonic blocking provide security during energization, while fifth-harmonic blocking provides security for overexcitation conditions. Fast subcycle external fault detection supervision adds security during external faults that have CT saturation.

Use the waveform-based inrush detection method to augment the harmonic-blocking and -restraint functions to prevent differential element operation during an inrush condition with low second-harmonic content. Low harmonic content is typical for newer transformers with cores that are made out of an improved iron core type, which has a different B-H characteristic (linear for high values of field intensity) than traditional transformers. In addition to the inrush detection algorithm, the waveform-based method also has a bidirectional differential overcurrent scheme that differentiates between an internal fault and an inrush condition.

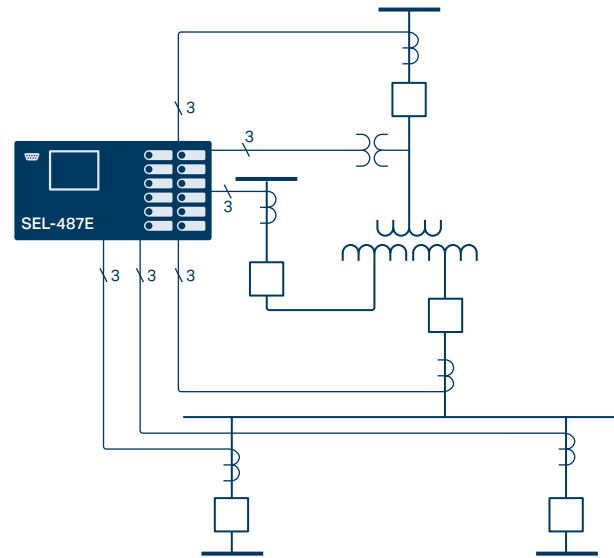

Protection Using Any Combination of Nominal CT Inputs

You can order any combination of nominal CT inputs at 5 A and 1 A for each transformer winding, including the following examples:

- 1 A on high-voltage side, 5 A on low-voltage side.
- 1 A on high-voltage side, 5 A on low-voltage side, 1 A on tertiary side.

Support up to 35:1 CT ratio mismatch without a loss of performance.

Possible applications include:

- Breaker-and-a-half installation.
- Busbar protection for up to six terminals with mismatched CT ratios.

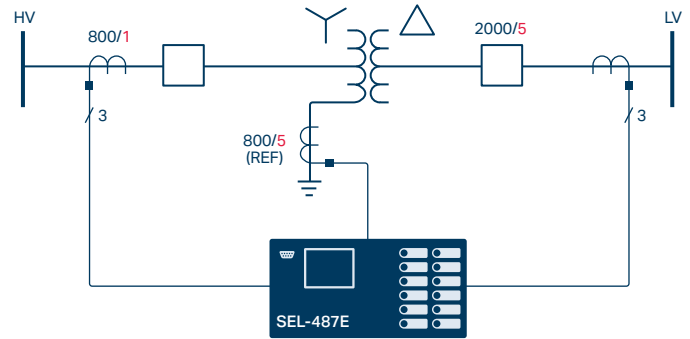

Comprehensive Time Overcurrent Protection

Eliminate the need to change settings groups to accommodate different time overcurrent pickup and time dial settings. The programmable time delay and pickup levels in the selectable time overcurrent elements allow the pickup and time delay settings to change dynamically, without needing to switch settings groups. You can choose from ten time overcurrent curves.

Programming the time delay and pickup levels as math variables allows the numeric value of the pickup and time delay settings to change based on any number of conditions, without the short delay of having to change relay settings groups. For example, you can change pickup and time delay settings dynamically in a parallel-transformer application based on single- or parallel-transformer configurations. Another example would be to change feeder time overcurrent element pickup and coordination delays based on distributed generation being connected downstream of a transformer.

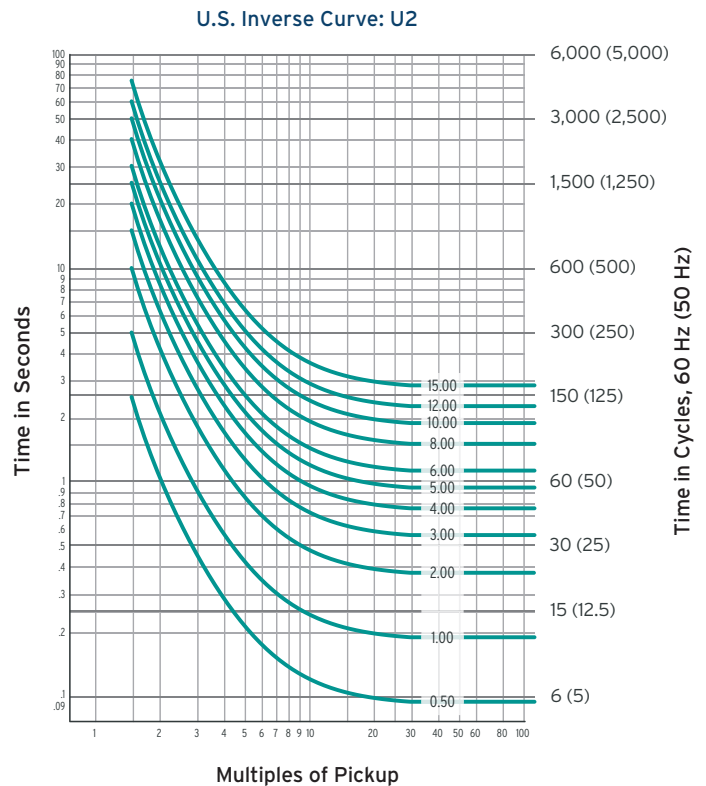

Flexible Transformer Backup and Feeder Protection

When voltage inputs are connected to the SEL-487E, directional elements can supervise phase and ground overcurrent elements on a per-terminal basis. The phase and ground directionally controlled overcurrent elements provide backup protection for transformer differential or feeder overcurrent relays. Secure overcurrent elements for feeder protection by using the optional per-terminal second-harmonic-blocking feature. Voltage-polarized directional elements supervise currents that are on the same side of the transformer as the selected polarizing voltages.

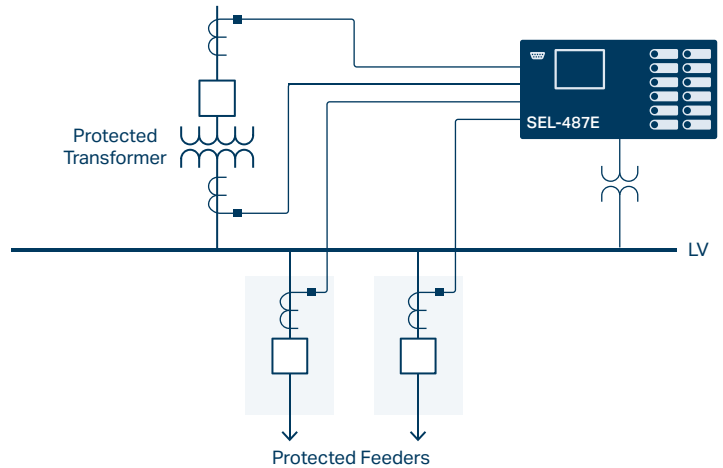

Enhanced Protection With Distance Elements

Assign the distance element to any terminal on the SEL-487E to provide up to four reversible zones of distance protection. The distance elements can be used for backup transformer or primary line protection.

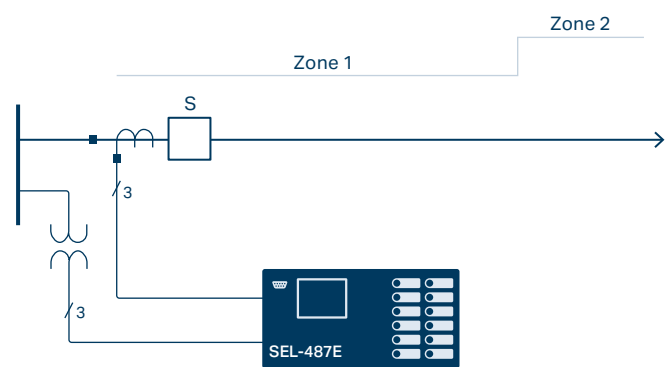
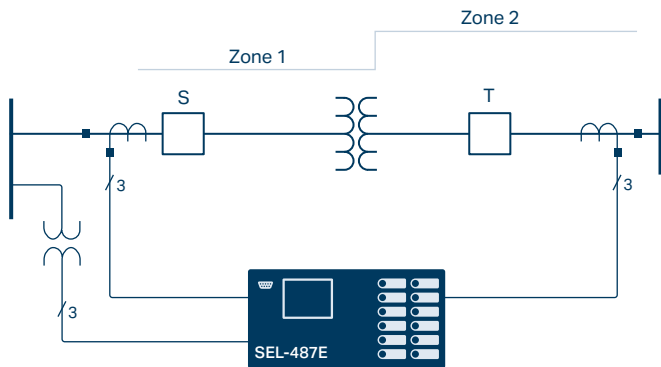

Thermal Protection and Monitoring

The SEL-487E provides the IEEE C57.91 and IEC 60255-149 thermal models for protection and monitoring the thermal response of top-oil and hotspot temperatures. Use the IEC thermal element to trip a breaker, or use either the IEC or the IEEE thermal elements to activate a control action or issue an alarm when the transformer is in danger of excessive insulation aging or loss of life. The relay includes three loss-of-insulation-life alarms: loss of life per day, total loss of life, and insulation aging factor.

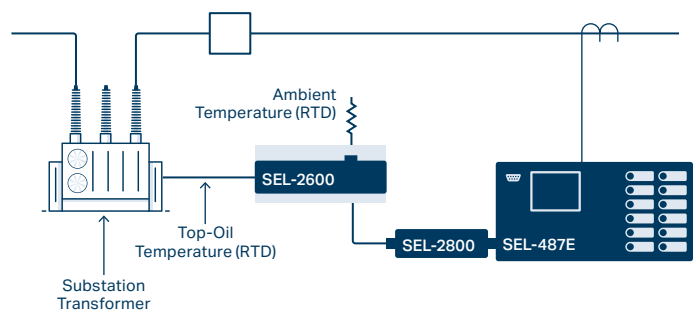

Centralized Protection and Control

The SEL-487E includes complete protection for small substations. The relay provides simultaneous protection for transformers, buses, lines, and feeders using a single device. Apply a second SEL-487E when redundancy is required. Use conventional relays, or apply a digital secondary system, such as IEC 61850-9-2 or TiDL, to meet your applications needs.

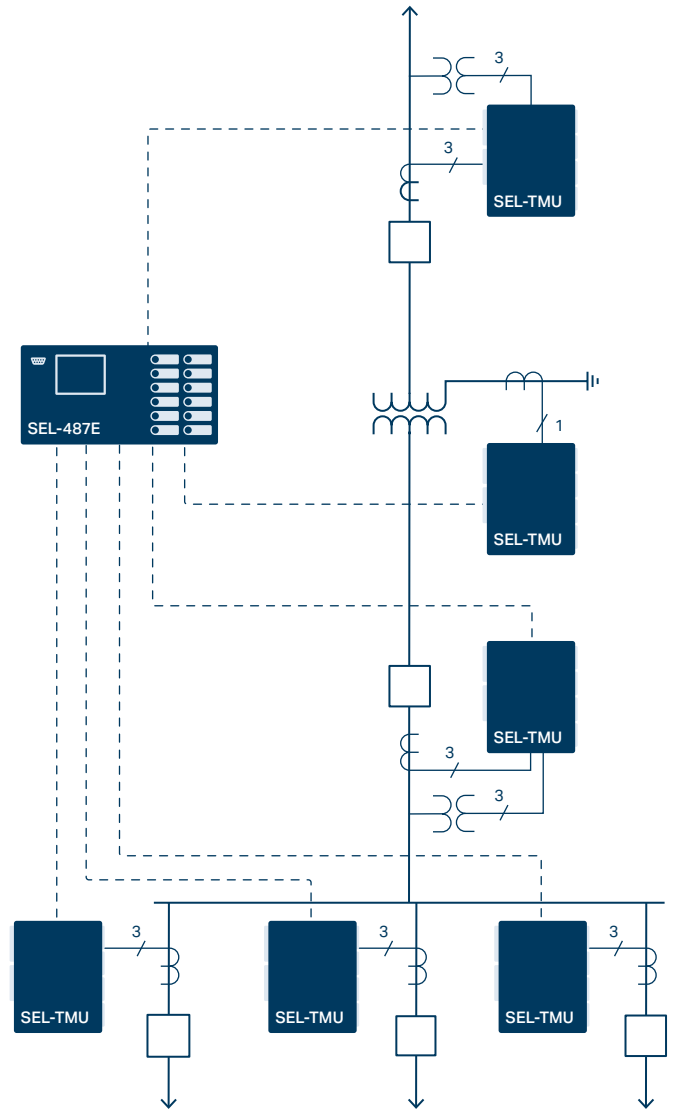

Pad-Mounted Switchgear

Use the SEL-487E to protect pad-mounted switchgear with a single device for up to 6 terminals. Protect all six terminals with comprehensive overcurrent elements, and secure each terminal from in-rush conditions with second-harmonic blocking. Use dynamic voltage source selection to automatically switch the voltage reference for each terminal.

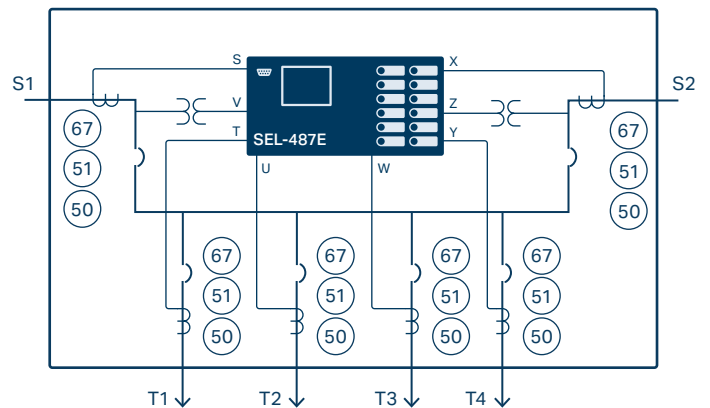

Through-Fault Monitoring

Track transformer wear with through-fault monitoring. You can gather current levels, the through-fault duration, and the date/time of each through fault. Through-fault currents can cause transformer winding displacement, leading to mechanical damage and increased transformer thermal wear. Monitoring cumulative through-fault duty helps you schedule proactive maintenance.

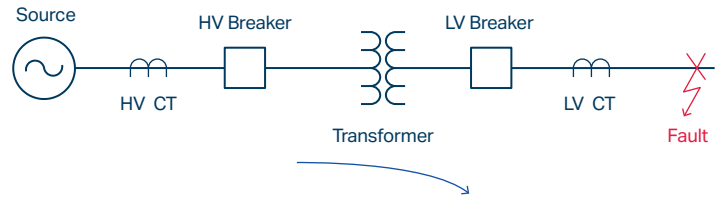

Circuit Breaker Monitoring

The SEL-487E features advanced circuit breaker monitoring. The relay processes phase currents, circuit breaker auxiliary contacts, and substation dc battery voltages to detect out-of-tolerance and maximum-life circuit breaker parameters. These parameters include interrupted current, operating times, and contact wear. By using SEL-487E monitoring, maintenance personnel can determine the extent of a developing circuit breaker problem and select an appropriate response to correct the issue.

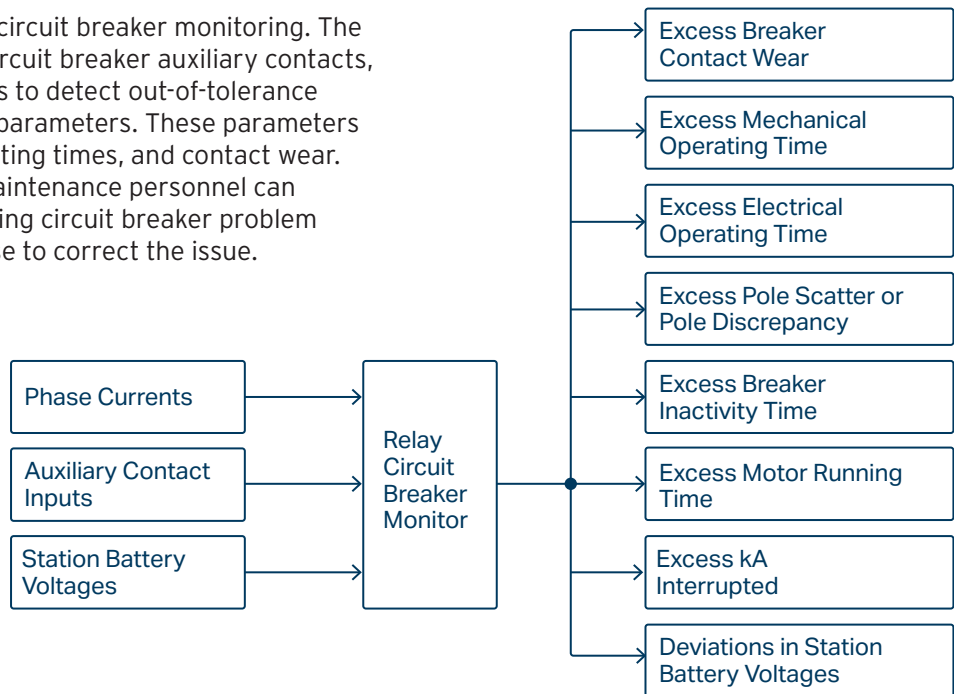

Synchrophasor Data for All CT and PT Channels

Improve power system quality and save money with SEL synchrophasors that are simultaneously available from all 24 analog channels (6 voltage and 18 current sources). With synchrophasors over serial or Ethernet communications, you can easily detect reactive loop flows, turn state estimation into state measurement, and provide early warning of potential system instability.

Simplify your system architecture and improve system operations with UDP multicast synchrophasor data. Configurable data streams allow you to select analog and binary information for up to five independent IEEE C37.118 data streams.

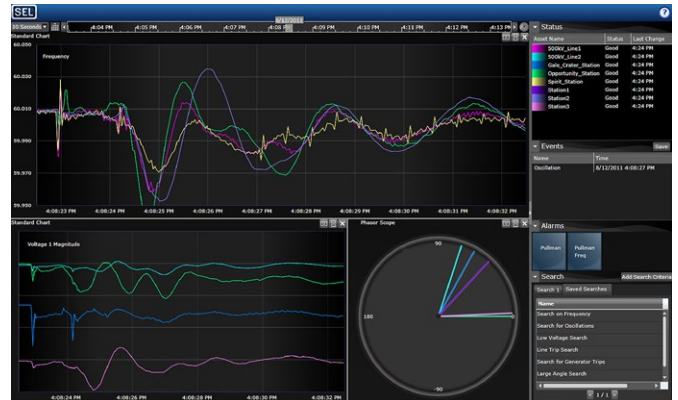

Real-Time Control

Improve system stability and reduce remote control requirements with real-time control. Direct relay-to-relay communication of synchrophasor values lets you apply remote measurements to local control. You can employ real-time values from remote transmission ends to control circuit breakers, static VAR compensators (SVCs), and power system stabilizers. The SEL-487E can control devices based on the voltage or current magnitude and phase angle, real or reactive power, or rate of change of the input quantities.

Share synchrophasor data between two or three SEL-487E relays for special protection schemes or custom logic. Remote measurements are available in SELLogic control equations for protection or automation.

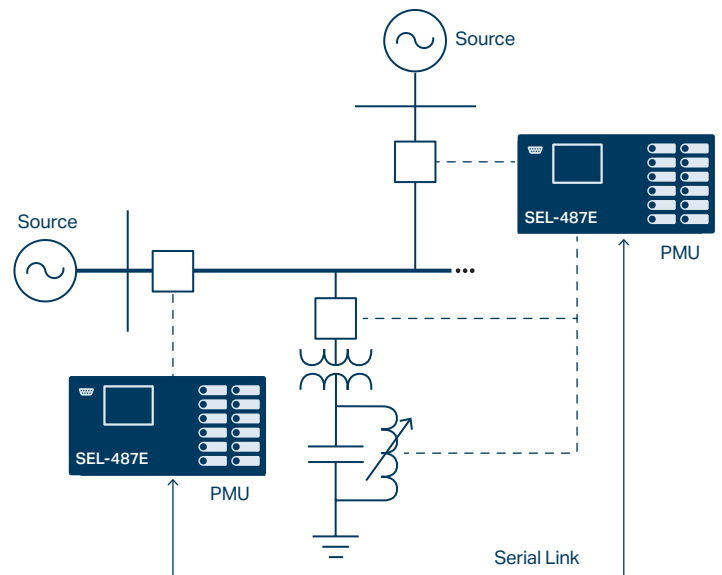

Station-Wide Synchrophasor Application

The SEL-487E is also a station-wide synchrophasor measurement and recording system. With 120 seconds of IEEE C37.118 binary synchrophasor data recording for all 24 analog channels, it can serve as a central PMU in any substation or power generation facility. The SEL-487E measures voltage magnitudes and current phase angle relationships at generators and transformers, which are key source nodes for stability studies and load angle measurements.

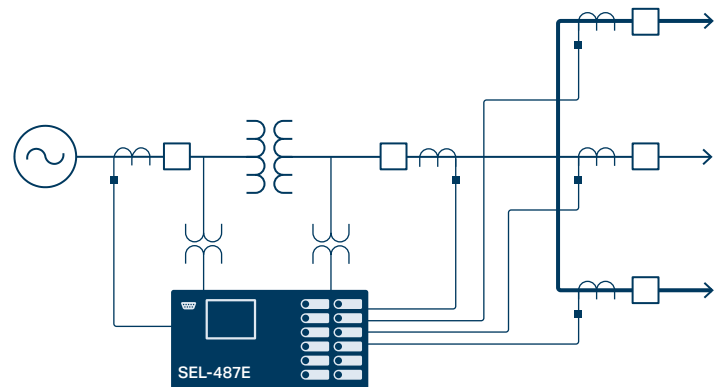

SEL TiDL Process Bus Solutions

SEL Time-Domain Link (TiDL) technology is a protection-centered digital secondary system solution engineered with simplicity in mind. This technology minimizes cybersecurity risks and network engineering by using point-to-point communications and a nonroutable protocol. A TiDL-based solution does not require an external time reference.

Simple Architecture

SEL-TMU devices are placed in the yard close to the primary equipment and digitize discrete I/O signals and analog data, such as voltages and currents. These data are then transported over fiber-optic cables to an SEL-487E-5 TiDL relay in the control house. The point-to-point architecture simplifies implementation and drives overall maintenance and maintenance costs down.

Data-Sharing Capabilities

Each SEL-TMU can be paired with up to four SEL-400 series TiDL relays. This data-sharing capability allows design flexibility, and point-to-point connections simplify system expansion.

Built-In Data Synchronization

TiDL relays measure the path delay between the relay and the merging unit on each connected port to align current and voltage measurements acquired from different merging units. This eliminates the need for external time sources, such as GPS clocks, for synchronization. All data from the SEL-TMU devices are synchronized with each other regardless of the number of units connected to the SEL-487E-5 relay or the length of the fiber.

Strong Cybersecurity Posture

The dedicated, deterministic TiDL system helps secure mission-critical systems. The isolated point-to-point connections and the absence of switches and routers reduce the electronic security perimeter and limit attack points. This security-minded architecture prevents remote access, and its simplicity eliminates the need for managing port access.

Minimal Training Required

The relay settings for the SEL-487E-5 TiDL relay are the same as those in the conventional SEL-487E-3 relay model, providing consistency and simplicity.

Flexible Communications Options

The SEL-487E can be configured with a five-port Ethernet card supporting PRP or failover functionality to increase system availability. Use PTPv2 on process bus or station bus ports to provide time synchronization.

This card also features dedicated ports and IP addresses for station bus and engineering access networks to provide selective access control.

Use small form-factor pluggable (SFP) transceivers on TiDL, process bus, station bus, and engineering access ports. Single- and multimode communications options provide increased flexibility.

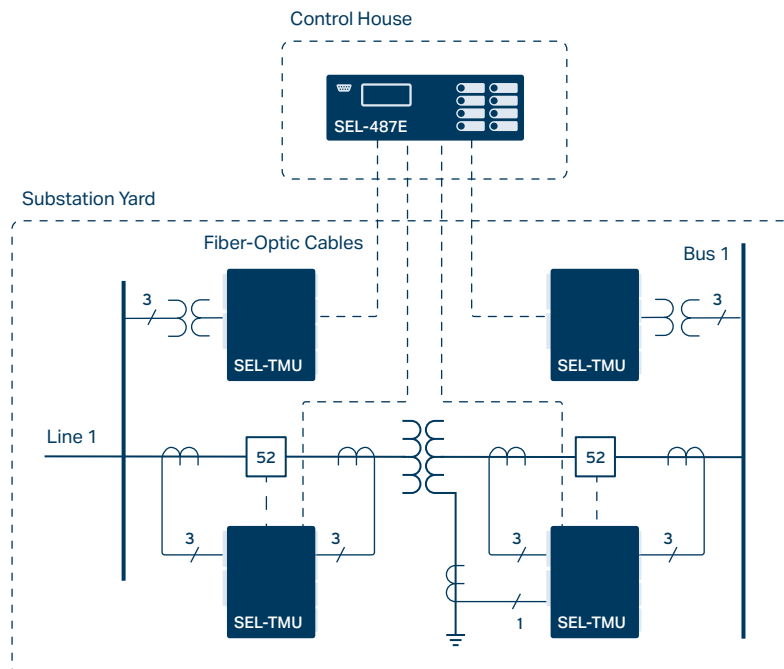

SEL-487E-5 With TiDL Technology

4U chassis with horizontal mounting options (panel or rack) accommodates your application needs.

Select a five-port Ethernet card for dedicated station bus and engineering access ports.

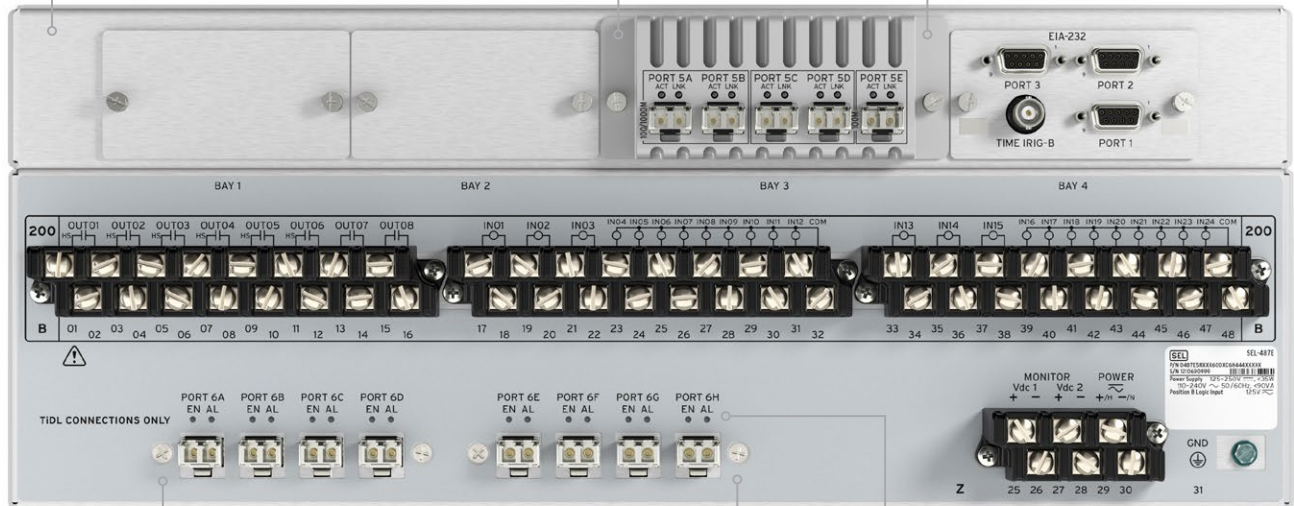

Eight SFP ports allow the TiDL relay to connect with eight remote SEL-TMU devices and to receive remote analog and digital data.

LEDs for viewing the connection status to an SEL-TMU on a per-port basis.

SEL SV-Based Process Bus Solutions

SEL Sampled Values (SV)-based solutions are communications-centric, network-based solutions that combine protection in the merging unit with the flexibility of IEC 61850-9-2.

Networked Architecture

The SEL-487E-5 SV relay in the control house receives digitized analog signals from SV merging units (publishers) in the yard via a fiber-based Ethernet network. SEL SV-based solutions allow you to create a flexible Ethernet-based network using tools such as software-defined networks or VLANs. You can use SEL software-defined networking (SDN) switches to provide centralized traffic engineering and improve Ethernet performance. SEL SDN switches act as transparent PTP clocks that support the IEEE C37.238 power system profile, ensuring submicrosecond time synchronization of the end devices.

Merging Units With Built-In Protection

Apply the SEL-487E-5 SV publisher to provide full SEL-487E protection locally while sending digitized voltage and current signals to other SV relays. All SEL SV merging units offer local protection for a variety of applications, depending on the model. If IEC 61850 network communications are lost, the SEL merging units continue to provide standalone protection.

Interoperability

SEL-487E-5 SV relays and other SEL SV devices are fully compliant with IEC 61850-9-2 and the UCA 61850-9-2LE guideline. You can use them with primary equipment that generates SV streams or with other manufacturers' SV-compliant units.

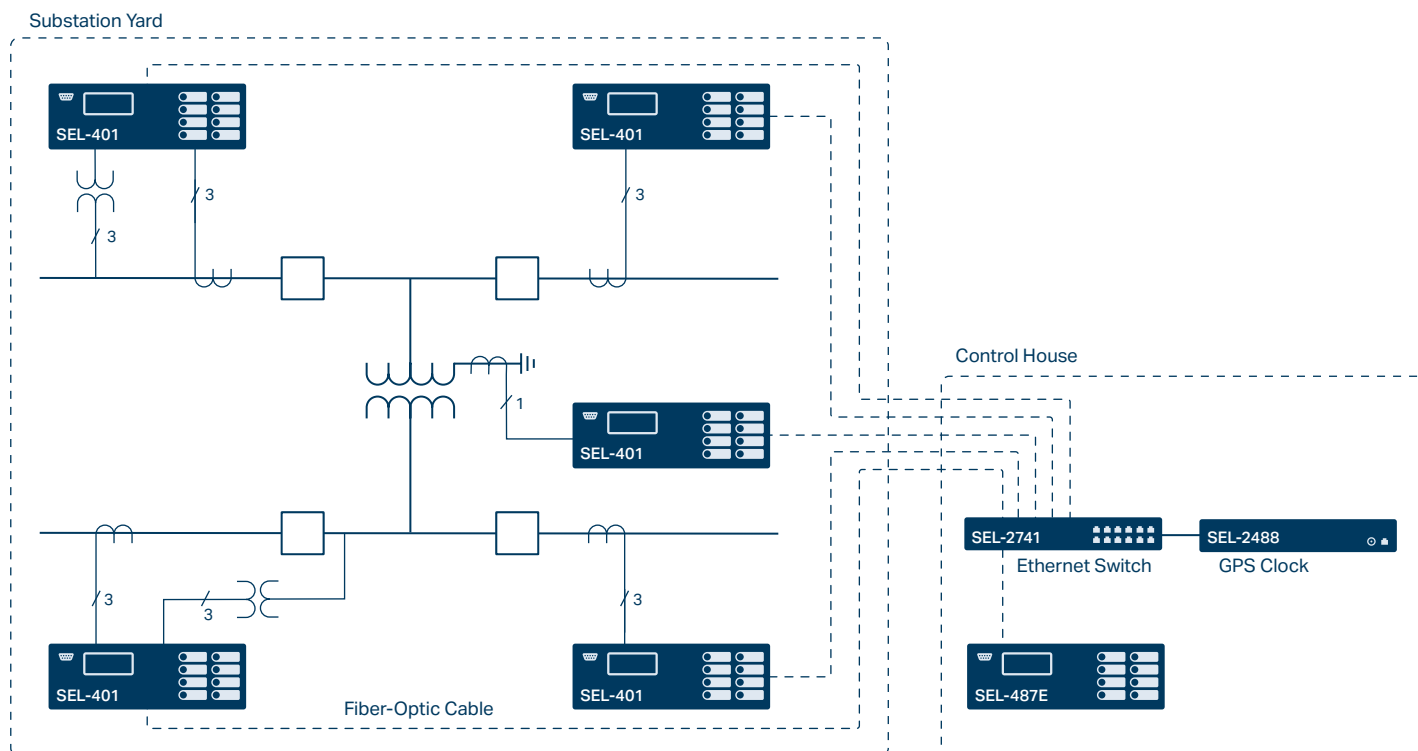

Advanced Network Monitoring and Diagnostic Tools

The SEL-487E-5 SV relay provides advanced network monitoring and diagnostic tools through standard IEC 61850 logical nodes. Additional diagnostic information and statistics are available through COM SV, GOO, ETH, and COM PRP commands, which aid in troubleshooting. The TEST SV command allows you to check the network connectivity as well as the CT and PT ratios between publisher and subscriber devices.

Flexible Communications Options

The SEL-487E can be configured with a five-port Ethernet card supporting PRP, HSR, or failover functionality to increase system availability. Use PTPv2 on process bus or station bus ports to provide time synchronization.

This card also features dedicated ports and IP addresses for station bus and engineering access networks to provide selective access control.

Use SFP transceivers on process bus, station bus, and engineering access ports. Single- and multimode communications options provide increased flexibility. All ports support 100 Mbps SFPs, and process bus ports also support 1 Gbps SFPs.

SEL-487E-5 With SV Technology

Select a five-port Ethernet card for dedicated process bus, station bus, and engineering access ports.

The 4U chassis has various mounting options to accommodate hardware needs.

Choose an SFP transceiver to match application requirements. Process bus ports support 100 Mbps and 1 Gbps connections. Station bus and engineering access support 100 Mbps connections. Select single- or multimode fiber.



SEL-487E SV Merging Unit

Chassis options (up to three I/O boards) to accommodate hardware needs

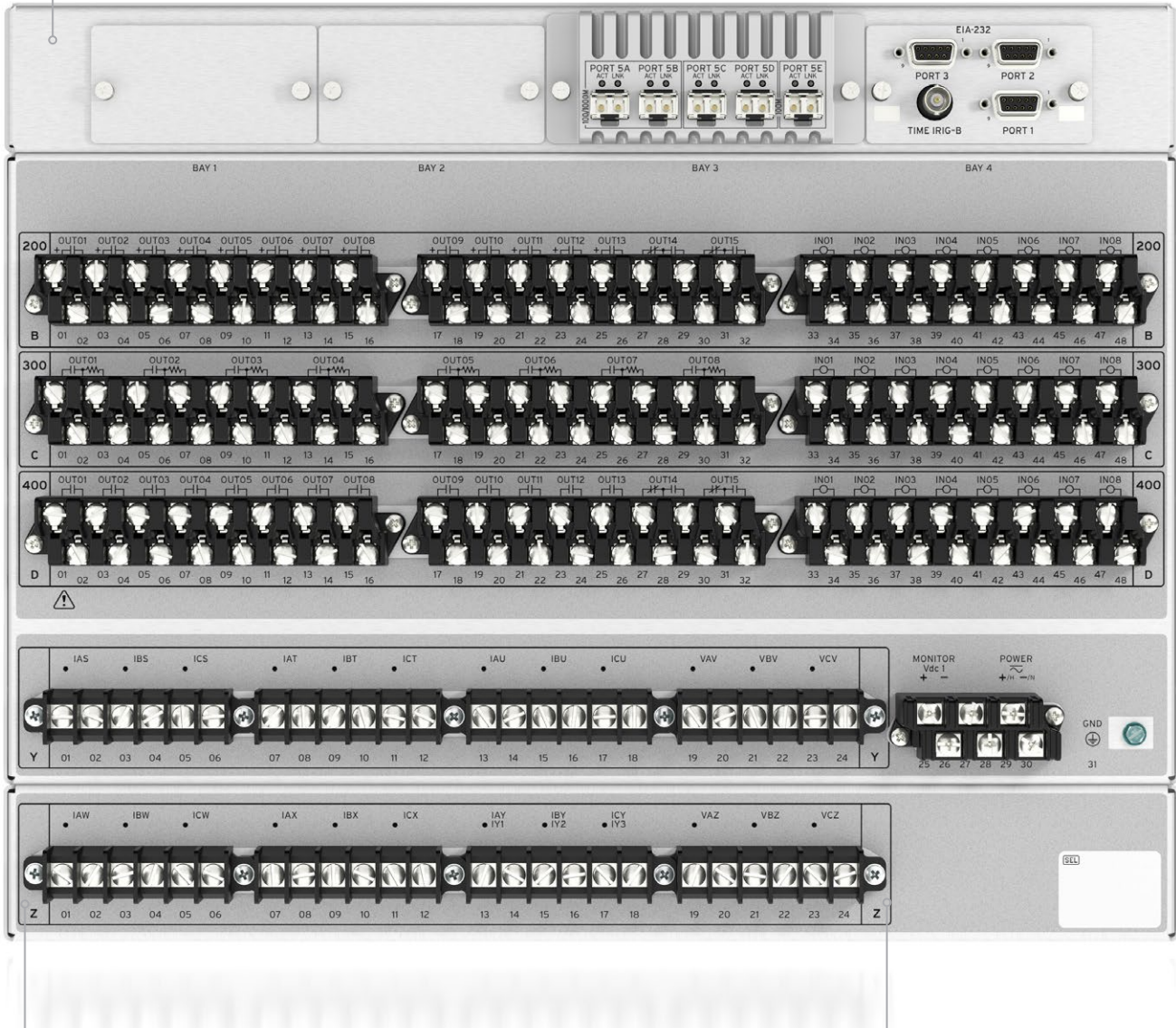

18 current and 6 voltage analog inputs to support signal digitization and local protection schemes

Accessibility and Communications

Built-In Web Server

Access basic SEL-487E information on a standard Ethernet network with the built-in web server. From there you can view the relay status, Sequential Events Recorder (SER) data, metering information, and settings with easy access within a local network. For increased security, web server access requires a relay password and the information is limited to a read-only view.

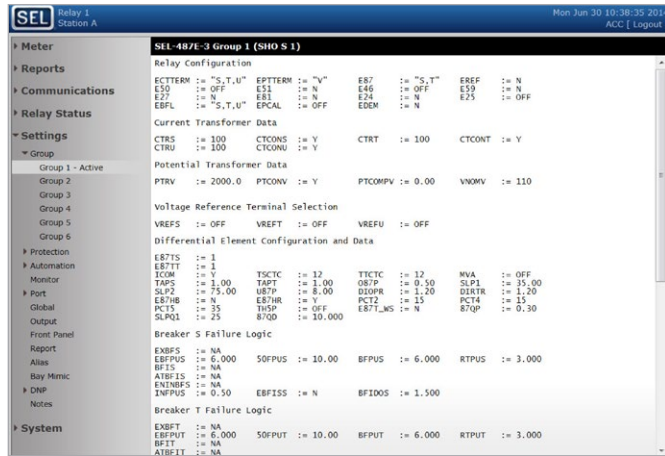

MIRRORED BITS Communications

This field-proven technology provides simple and powerful bidirectional digital communications between devices. MIRRORED BITS communications can transmit/receive information between relays for better coordination.

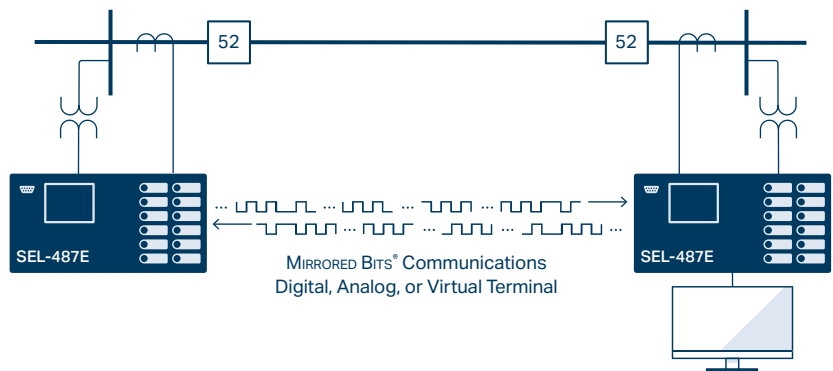

Ethernet-Based Communications

An Ethernet communications card enables you to communicate using a variety of protocols, including FTP, HTTP, DNP3, PTPv2, PRP, HSR, Telnet, synchrophasors, and IEC 61850 Edition 2.1. Select between copper, fiber, or a combination of port types.

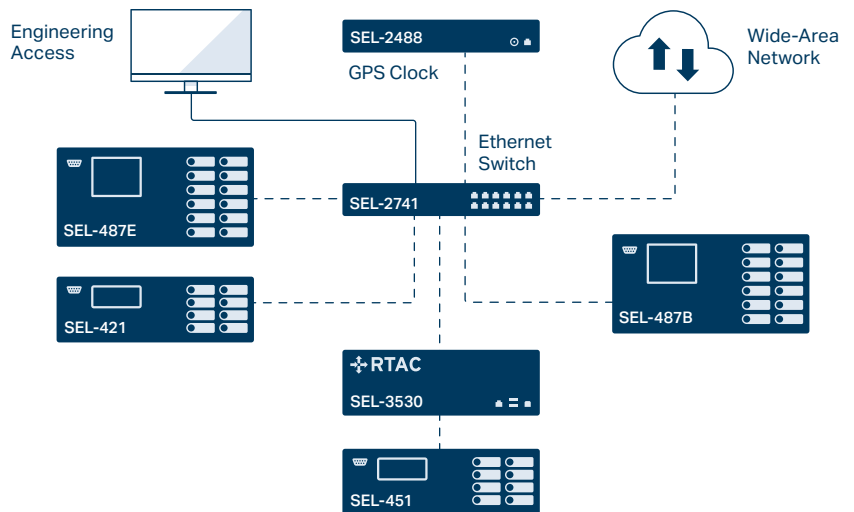

Setting and Commissioning Software

Save Time and Eliminate Costly Errors With SEL Commissioning Assistant Software

SEL Commissioning Assistant Software recommends matrix compensation settings after automatically identifying incorrect field wiring and improper CT configurations, such as incorrect CT polarities, inconsistent CT ratios, or crossed phases.

Apply the Commissioning Assistant in Five Easy Steps

1. Define the system one-line diagram.
2. Assign any two windings to conduct a test.
3. Validate the current flow, CT ratios, and polarity.
4. Run the test to start the matrix calculation process.
5. Document and implement the correct compensation matrix recommended for the transformer application.

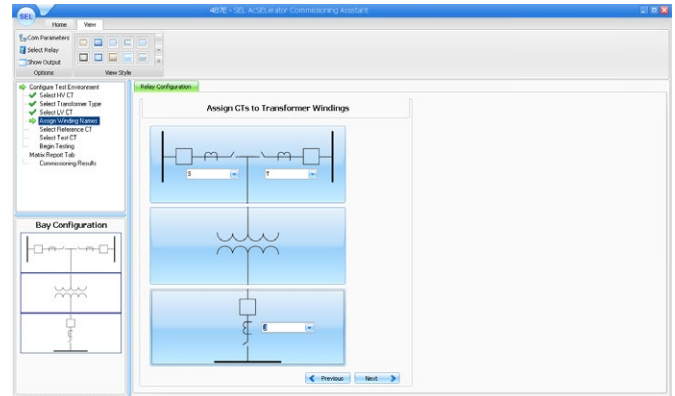

Simplify the SEL-487E Configuration Process With the Graphical Logic Editor (GLE)

With the GLE, you can view SELogic control equations graphically and document settings files for easier validation and commissioning. You can also convert existing SELogic control equations to easy-to-read diagrams and save diagrams with your ACSELERATOR QuickSet® SEL-5030 Software settings.

The GLE capability in QuickSet makes it easy to design new SELogic control equations with the convenient diagram navigation tool, drag-and-drop interface, function block diagrams, and automatic layout function. You can manage your control diagrams with a full element palette. The GLE aids in reducing design errors and reducing the time and expense of commissioning relays.

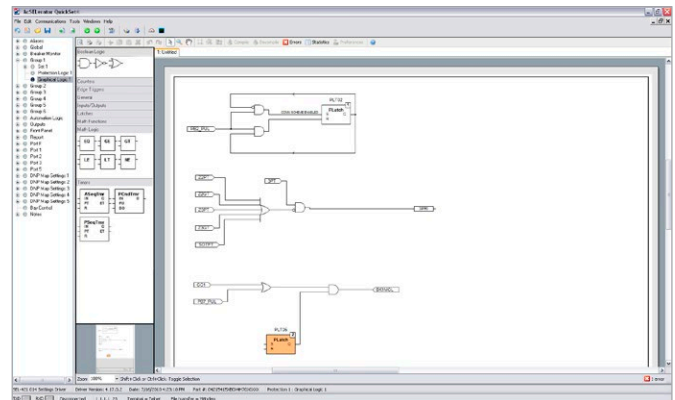

Next-Generation Configuration Software

Included with the TiDL and SV relays, SEL Grid Configurator allows engineers and technicians to quickly create, manage, and deploy settings for SEL power system devices. It features a modern interface designed for ease of use, with powerful protection visualization and comprehensive reporting to reduce device deployment complexity.

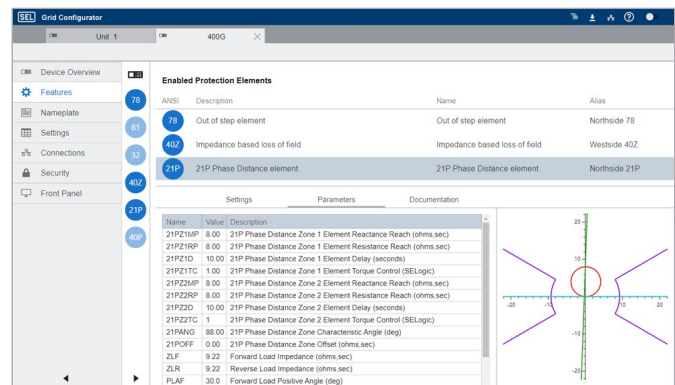

SEL-487E Specifications

General			
AC Current Inputs (18 total)	5 A nominal 1 A nominal 1 A/5 A nominal (Y terminal only [REF])	TiDL Ports	Fiber-optic SFP ports: 8 Range: ~2 km Data rate: 100 Mbps Protocol: SEL T-Protocol
AC Voltage Inputs (6 total)	0–300 V _{L-N} operational	SV Ports	Subscriber: As many as 7 SV data streams Publisher: As many as 7 SV data streams Data rate: 4.8 kHz for 60 Hz system or 4 kHz for 50 Hz system Protocol: IEC 61850-9-2
LEA Voltage Inputs	0–8 V _{L-N} operational	Precise-Time Input	Demodulated IRIG-B time input and PTPv2
Communications Protocols	FTP, Telnet, SEL ASCII, SEL Fast Message, synchrophasors, DNP3, PRP, HSR, PTPv2, and IEC 61850 Edition 2.1 (optional)	Processing	AC voltage and current inputs: 8,000 samples per second Protection and control processing: 8 times per power system cycle
Communications Ports	<p>Serial Ports One front-panel and three rear-panel EIA-232 serial ports 300–57,600 bps</p> <p>Two-Port Ethernet Card Two 100BASE-FX fiber-optic network ports</p> <p>Four-Port Ethernet Card Four 10/100BASE-T twisted-pair network ports, or Four 100BASE-FX fiber-optic network ports, or Two 10/100BASE-T twisted-pair network ports and two 100BASE-FX fiber-optic network ports</p> <p>Five-Port Ethernet Card Two 100/1000BASE SFP ports Three 100BASE SFP ports</p>	Power Supply	24–48 Vdc 48–125 Vdc or 110–120 Vac 125–250 Vdc or 110–240 Vac
		Operating Temperature	–40° to +85°C (–40° to +185°F)

SEL SCHWEITZER ENGINEERING LABORATORIES

Making Electric Power Safer, More Reliable, and More Economical
+1.509.332.1890 | info@selinc.com | selinc.com

© 2025 by Schweitzer Engineering Laboratories, Inc.
PF00168 • 20250313

